



INSTALLATION INSTRUCTIONS FOR PART 99-7424

APPLICATIONS

Nissan Titan 2008-11

99-7424

KIT FEATURES

- DIN Radio Provision with Pocket
- ISO Mount Radio Provision with Pocket
- Painted To Match Factory Dash



KIT COMPONENTS

- A) Single DIN Radio Housing • B) ISO Trim Plate • C) ISO Brackets • D) Trim Panel
• E) Two Sided Tape (Not Shown)

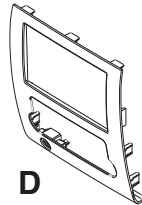
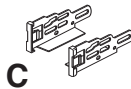
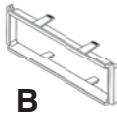
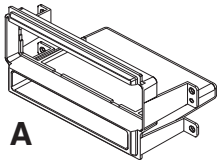

Harness & Antenna Connections (sold separately)

- 70-7550 - Nissan Harness 95-up

TOOLS REQUIRED:

- Torx T-10 Driver • Small Flat Blade Screwdriver/ Panel Removal Tool
• Phillips Screwdriver



1-800-221-0932



www.metraonline.com

© COPYRIGHT 2010 METRA ELECTRONICS CORPORATION



TABLE OF CONTENTS

Dash Disassembly

Nissan Titan 2008-11 1

Kit Preparation 2

Kit Assembly

- DIN Radio Provision with Pocket. 3

- ISO Mount Radio Provision with Pocket. 4

Final Assembly 5

***Note:**

Refer also to the instructions included with the aftermarket radio.

NISSAN Titan 2008-11

- 1 Disconnect the negative battery terminal to prevent an accidental short circuit.
- 2 Unclip the entire dash panel including the radio and climate controls. Unplug and remove the panel. (Figure A)
- 3 Remove (4) Phillips screws securing the radio chassis. Unplug and remove the chassis. (Figure B)
- 4 Remove (4) T-10 Torx screws securing the climate controls to the dash panel and remove the controls from the panel. (Retain the screws and climate controls for re-use during kit preparation.) (Figure C)
- 5 Remove (2) T-10 Torx screws securing the passenger air bag status light assembly to the dash panel and remove the light from the panel. (Retain the screws and light for re-use during kit preparation.) (Figure C)

NOTE: The small round Airbag sticker also needs to be removed from the factory panel and placed onto the 99-7424 radio housing panel. (A round piece of double-sided tape is provided in case the factory sticker is not strong enough.) (Figure C)

Continue to kit preparation

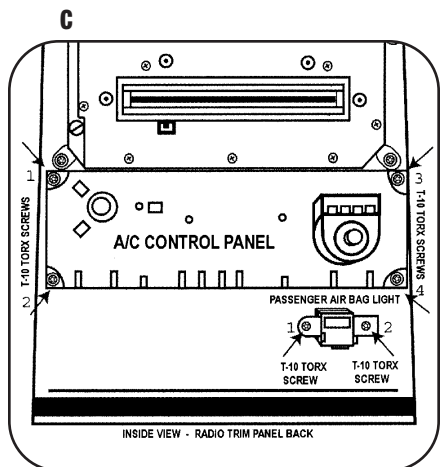
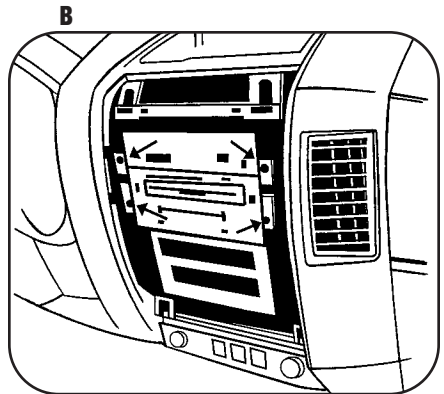
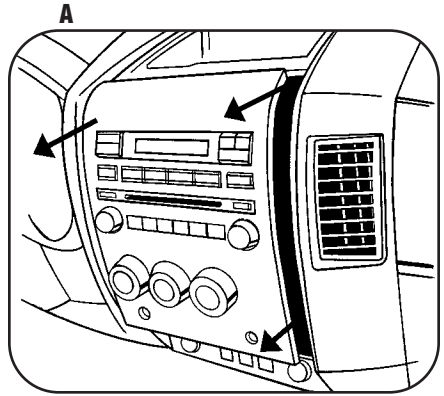

NISSAN Titan 2008-11

- 1** Attach the climate controls to the Trim Panel using the factory hardware removed during the dash disassembly. (Figure A)

- 2** Attach the passenger air bag status light assembly to the Trim Panel using the factory hardware removed during the dash disassembly. Also, apply to air bag button the small round airbag sticker previously removed in Step 5 dash disassembly. (Figure B)

Continue to kit assembly.

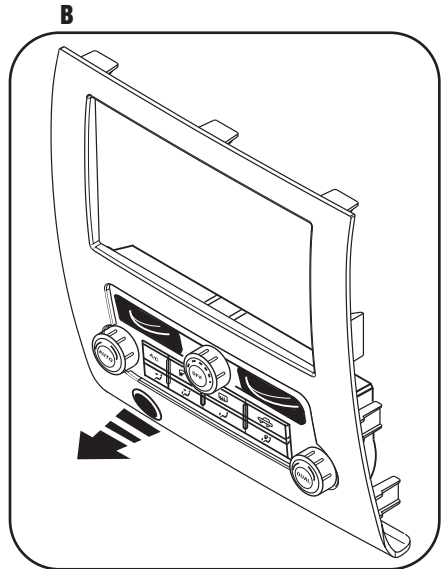
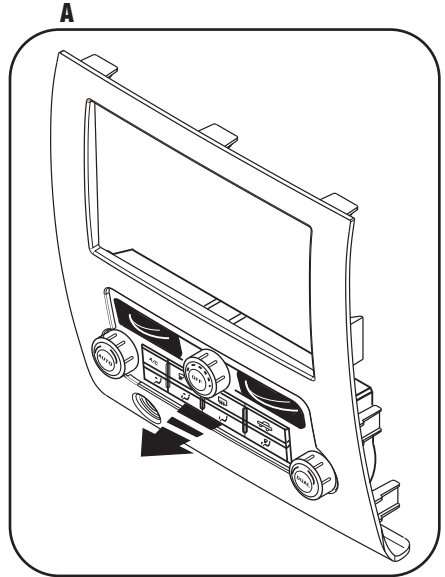

DIN RADIO PROVISION WITH POCKET

**Note: Refer also to the instructions included with the aftermarket radio.*

- 1 Slide the DIN cage into the Single DIN Radio Housing and secure by bending the metal locking tabs outward.
- 2 Slide the aftermarket radio into the cage until it snaps into place. (Figure B)

Continue to final assembly.

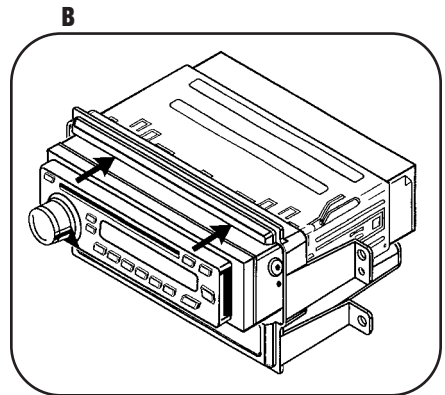
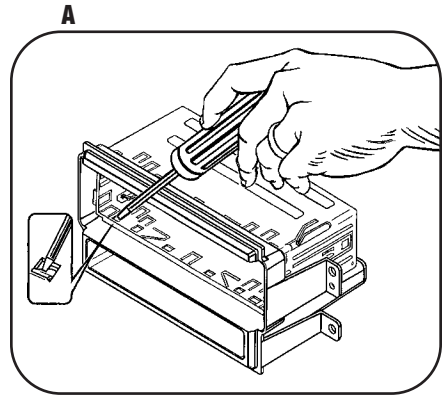

ISO MOUNT RADIO PROVISION WITH POCKET

**Note: Refer also to the instructions included with the aftermarket radio.*

- 1** Mount the ISO Brackets to the radio using the screws supplied with the radio. (Figure A)
- 2** Slide the radio into the radio housing until it snaps into place. (Figure B)
- 3** Snap the Trim plate onto the front of the Radio Housing. (Figure B)

Continue to final assembly.

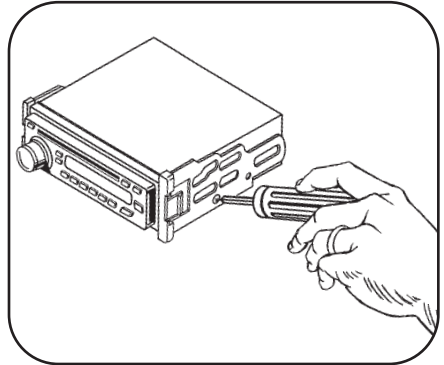
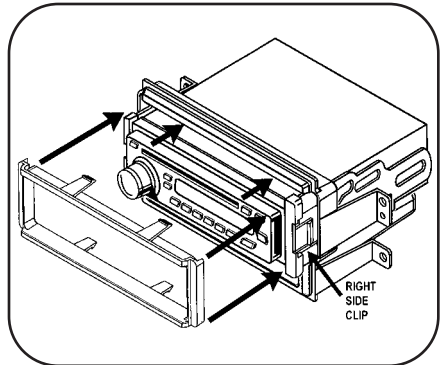
A

B

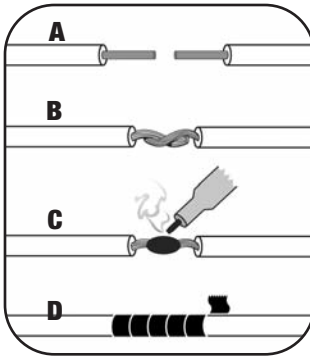
FINAL ASSEMBLY



- (A) Strip wire ends back 1/2"**
- (B) Twist ends together**
- (C) Solder**
- (D) Tape**

- 1** Locate the factory wiring harness in the dash. Metra recommends using the proper mating adapter and making connections as shown. (Isolate and individually tape off the ends of any unused wires to prevent electrical short circuit.)
- 2** Re-connect the negative battery terminal and test the unit for proper operation.
- 3** Reassemble in reverse order of disassembly using the 99-7424 Trim Panel in place of the factory radio trim panel.

FINAL WIRING CONNECTIONS

Make wiring connections using the EIA color code chart shown below and the instructions included with the head unit. Metra recommends making connections as shown below; Strip, Splice, Solder, Tape. Isolate and individually tape off ends of any unused wires to prevent electrical short circuit.

METRA / EIA WIRING CODE

12V Ignition / Acc. Red	Right Front (+) Gray
12V Batt / Memory Yellow	Right Front (-) Gray/ Black
Ground Black*	Left Front (+) White
Power Antenna Blue	Left Front (-) White / Black
Amp Turn-On Blue / White	Right Rear (+) Violet
Amp Ground Black / White	Right Rear (-) Violet / Black
Illumination Orange	Left Rear (+) Green
Dimmer Orange / White	Left Rear (-) Green / Black

***NOTE:** When a Black wire is not present, ground radio to vehicle chassis.
All colors may not be present on all leads due to manufacturer's specifications.

99-7424 INSTRUCTIONS



1-800-221-0932



www.metraonline.com

REV. 11/18/10 © COPYRIGHT 2010 METRA ELECTRONICS CORPORATION INST99-7424