

Programme Series

**30E/35E**

**30ET/35ET**



# **OWNER'S MANUAL**



**OPERATING MANUAL AND USER GUIDE**

# Programme Series 30E/30ET/35E/35ET



## IMPORTANT WARNINGS & SAFETY INSTRUCTIONS

**1. READ ALL INSTRUCTIONS** carefully and become familiar with the features and functions of these products before operating them.

**2. RETAIN THESE INSTRUCTIONS** for future reference.

**3. COMPLY WITH ALL WARNINGS –**

All warnings and instructions for this product should be adhered to.

**4. USE WITH AMPLIFIERS** – In order to avoid damage to drivers and other equipment, it is advisable to establish and follow a routine for powering up and powering down a sound system. With all system components connected, turn on source equipment (mixers, signal processors, record and playback units, etc.) **BEFORE** powering up amplifiers. Transient voltages from powering up source equipment can damage speakers if amplifiers are already turned on. Make sure that amplifier volumes are set to their minimum settings and power up any system amplifiers **LAST**. It is recommended that all system components be allowed to stabilize for several seconds before any source signals are introduced or level setting adjustments are made. Similarly, when shutting systems down, turn all amplifiers off first, before powering down any other system components.

**5. CABLES** – Do not use shielded or microphone cables for connection between amplifiers and speakers. Use only approved speaker cables with proper connectors.

**6. RIGGING – SUSPENDING – MOUNTING** – Rigging, suspending and mounting of these speaker systems can expose members of the public to serious health risks and even death. **UNDER NO CIRCUMSTANCES ATTEMPT TO RIG, SUSPEND OR OTHERWISE MOUNT THESE SPEAKERS UNLESS YOU ARE FULLY QUALIFIED AND CERTIFIED TO DO SO BY RELEVANT LOCAL, STATE AND NATIONAL AUTHORITIES. ALL RELEVANT SAFETY REGULATIONS MUST BE FOLLOWED. IF YOU ARE NOT PROPERLY QUALIFIED OR DO NOT KNOW OF PERTINENT REGULATIONS, CONSULT QUALIFIED PERSONNEL FOR ADVICE.**

**7. CAUTION** – These professional loudspeaker systems are capable of generating very high sound pressure levels. Use care with placement and operation to avoid exposure to excessive volume levels. Permanent hearing damage can result when operated to extreme levels.

**8. SERVICE** – There are no user serviceable parts inside this product. Users should not attempt to service this product. Warranty nullification could result if this is attempted.

# Programme Series 30E/30ET/35E/35ET



## TABLE OF CONTENTS

### Page

|         |  |
|---------|--|
|         | Important Warnings and Safety Instructions |
| 2.....  | What about the Programme Series?           |
| 3.....  | Introduction and Overview                  |
| 4.....  | Features                                   |
| 5.....  | Setting up/ Speaker Placement              |
| 7.....  | Connections/Wiring                         |
| 9.....  | Specifications                             |
| 10..... | Dimensional Drawings                       |
| 11..... | Warranty                                   |

# Programme Series 30E/30ET/35E/35ET



## WHAT ABOUT THE PROGRAMME 30E/30ET/35E/35ET LOUDSPEAKERS?

Wharfedale Programme Series of foreground/back-ground music speakers are designed for demanding professional applications such as reproduction and reinforcement of music and sound in venues as diverse as airports, places of worship, schools, retail shops, restaurants and public houses.

When you need a powerful, easy to install and use sound reinforcement or background music system, you choose the system that can deliver the biggest sound for your money. The **Programme 30E/30ET/35E/35ET** system is just what you asked for.

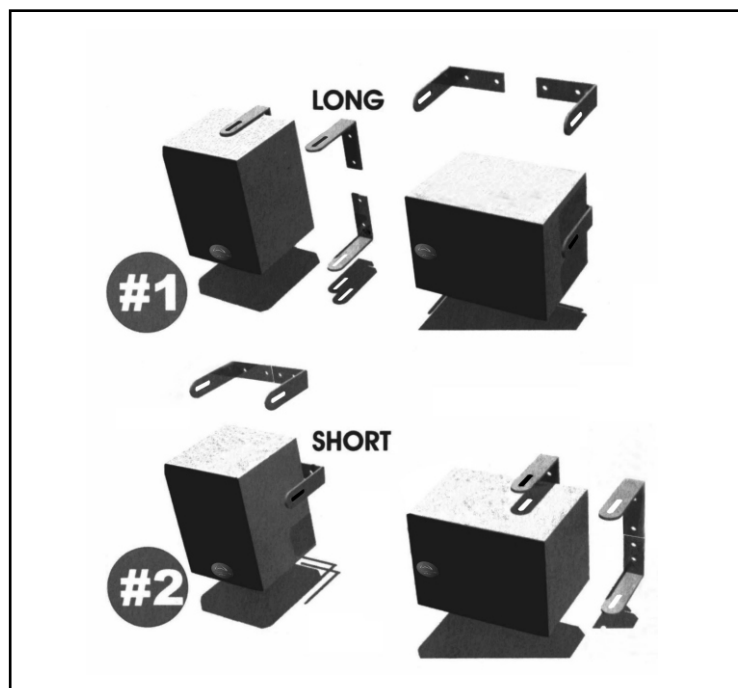

# Programme Series 30E/30ET/35E/35ET



## INTRODUCTION

### Thank You

Wharfedale **Programme Series** loudspeakers are the result of many years of experience in the use, design and manufacturing of professional loudspeaker products. We take great pride in engineering and building every Wharfedale Pro loudspeaker and wish to thank you for entrusting us with your sound.

Please take a few minutes to read this manual completely in order to ensure that you get the most out of your **Programme Series** Loudspeaker system.

### PROGRAMME 30E/30ET/35E/35ET OVERVIEW:

The **Programme 30E/35E** loudspeaker system is designed to deliver accurate, high power sound in a lightweight, small and easy to install package.

From the selection of components, to the High Frequency Driver protection circuit *pro-tech*<sup>®</sup> (PTC) the **Programme 30E/35E** is designed from the ground up to be a workhorse. Feature laden and powerful, the **Programme 30E/35E** is the best choice for a small, big sounding loudspeaker.

The **Programme 30ET** and **Programme 35ET** speakers may be used in constant voltage distributed systems. With an internal 70v/100v transformer, you can economically install a background music or paging system, while still only using one (70v/100v) amplifier.

# Programme Series 30E/30ET/35E/35ET

## **FEATURES – Programme 30E/30ET**

- ❖ **2-way loudspeaker system**
- ❖ **1" (25.4mm) Mylar Dome drive unit**
- ❖ **Low distortion, high power, 5-1/4" (133.4mm) woofer**
- ❖ **50 Watts Continuous Power Handling**
- ❖ **High strength MDF cabinet**
- ❖ **Pro-tech® (PTC) driver protection**
- ❖ **Four (4) M6 hanging points**
- ❖ **Parallel Spring crimp Input Connectors**
- ❖ **Available with 100 Volt Transformer (T version)**
- ❖ **Universal Bracket Included**

## **FEATURES – Programme 35E/35ET**

- ❖ **2-way loudspeaker system**
- ❖ **1" (25.4mm) Silk Dome drive unit**
- ❖ **Low distortion, high power, 6" (152.4mm) woofer**
- ❖ **60 Watts Continuous Power Handling**
- ❖ **High strength MDF cabinet**
- ❖ **Pro-tech® (PTC) driver protection**
- ❖ **Four (4) M6 hanging points**
- ❖ **Parallel spring crimp input connectors**
- ❖ **Available with 70/100 Volt Transformer (T version)**
- ❖ **Universal Bracket Included**

# Programme Series 30E/30ET/35E/35ET



## **SETTING UP/ SPEAKER PLACEMENT**

The uniform dispersion of the **Programme 30E/30ET/35E/35ET** makes it easy to place the speakers where you need them, rather than trying to rearrange the room to accommodate the sound system. Try to keep the speakers above head level to get the full effect of the system and cover the most people.

The **Programme 30E/30ET/35E/35ET** is an excellent sound reinforcement or background music speaker. A set of wall mounting brackets is included with each pair of speakers to make installation easy and safe.

The **Programme 30E/30ET/35E/35ET** can be oriented in a vertical or horizontal position. All models have been designed for tabletop or bookshelf installation or, with the use of the included brackets they can be mounted on the wall or ceiling.

Don't worry about big rooms or rooms with hard to reach seats. The Programme "T" Series speakers have a transformer to allow the use of many more speakers than you would normally use. Use of the transformer is highlighted in the **Connections/ Wiring Section**.

# Programme Series 30E/30ET/35E/35ET

## Pro 30E/35E Line picture of the panel

  
**PROGRAMME35E**  
 NOMINAL IMPEDANCE 8 OHMS  
 POWER HANDLING 120W(PROGRAM)  
 SERIAL NO.    
 WWW.WHARFEDALEPRO.COM

  
**PROGRAMME30E**  
 NOMINAL IMPEDANCE 8 OHMS  
 POWER HANDLING 100W(PROGRAM)  
 SERIAL NO.    
 WWW.WHARFEDALEPRO.COM

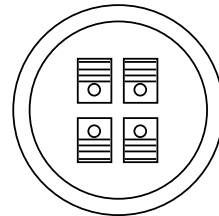
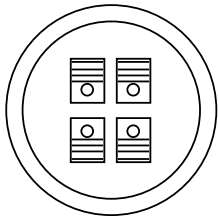

  
**PROGRAMME30ET**  
 SERIAL NO.    
 WWW.WHARFEDALEPRO.COM  
 10W 5W 2.5W 1.25W 100V C

  
**PROGRAMME35ET**  
 SERIAL NO.    
 WWW.WHARFEDALEPRO.COM  
 40W 20W 10W 5W 70V C  
 N/C 40W 20W 10W 100V C





# Programme Series 30E/35E

## CONNECTIONS/ WIRING

Wiring and setting up your **Programme 30E/30ET/35E/35ET** is as easy as plugging in a household appliance. You simply run your speaker cables from your amplifier to one of the parallel spring style input connectors on the **Programme 30E/30ET/35E/35ET** input panel.

The **Programme 30E/30ET/35E/35ET** accept stripped bare end cables. Attach the speaker cable securely to your Programme Series unit and power amplifier (the amplifier should be off). Use the correct gauge of speaker cable according to the power handling ability of your Programme Series cabinet. Use stranded insulated cable for speaker runs. It is always advisable to use heavier gauge (lower number) cables on longer runs.

Be sure to connect your speakers in proper polarity (what many refer to erroneously, as *phase*). This means that in normal operation; connect one end of the same wire to the Red terminal on the amplifier and the other end to the Red connector on the speaker. Black is always the ground or common.

Because the Programme Series is so flexible, you can wire many speakers in parallel or series or a combination of Series/Parallel. Follow the diagram below for wiring schemes .

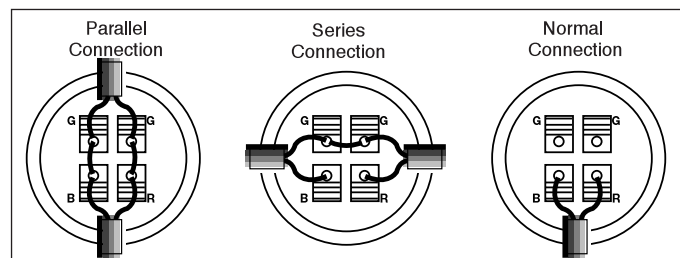

# Programme Series 30ET/35ET

## HIGH-IMPEDANCE/CONSTANT-VOLTAGE SYSTEM:

The Programme 30ET features an internal line-matching transformer with four power/impedance selections for 100-volt line. In speaker systems, anything over  $32\Omega$  is considered high impedance. Smaller wire can be used without excessive power loss. The four switchable power taps are 1.25W, 2.5W, 5W and 10W (Pro30ET) and 5W, 10W, 20W, 40W (Pro35ET).

If you are using the Pro30ET/35ET, wiring is just as easy - with a few more steps. You connect your speaker cable from the 70.6v or 100v output of your amplifier (or to an external line transformer) to the input terminals of the speaker. You will then have to adjust the wattage of the transformer to the correct setting.

As you would with any audio system, you will need to figure out how many speakers that you want to use and then divide that into the wattage of your power amplifier - you should not exceed that load, otherwise, you will encounter distortion.

$$\text{Transformer tap (W)} \Rightarrow \frac{\text{Amplifier Power}}{\text{Number of Speakers}}$$

Because of the low wattage limitations of the individual speakers, this set up is normally used in office sound systems and areas where you only want to hear background music, or occasional messages to everyone within a facility.

You connect the + (positive) side to the + connector and the - (negative) to the ground connector. If you are adding more speakers, connect your speaker wire from the LEFT side connector and run it to the + (positive) connector on the next speaker.

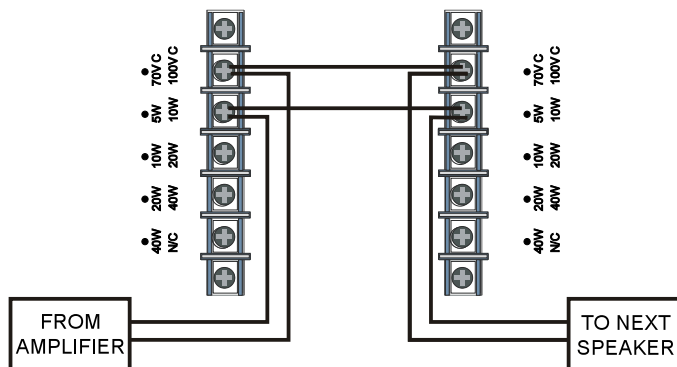

# Programme Series 30E/30ET/35E/35ET



## SPECIFICATIONS

|                                | <b>Programme 30E/30ET</b>       | <b>Programme 35E/35ET</b>          |
|--------------------------------|---------------------------------|------------------------------------|
| Type                           | 2-Way reflex                    | 2-way reflex                       |
| Frequency response             | 75Hz-20kHz                      | 65Hz – 20kHz                       |
| Peak SPL @ 1m                  | 109 dB                          | 112 dB                             |
| Sensitivity (1W @ 1M)          | 86 dB                           | 88 dB                              |
| Coverage Pattern (degrees)     | 70° H x 70°V                    | 70° H x 70°V                       |
| Nominal Impedance              | 8 Ohms                          | 8 Ohms                             |
| Power                          |                                 |                                    |
| Continuous                     | 50 Watts                        | 60 Watts                           |
| Program                        | 100 Watts                       | 120 Watts                          |
| Peak                           | 200 Watts                       | 240 Watts                          |
| Low Frequency Driver           | 5-1/4" (133.4mm)                | 6-1/2" (165.1mm)                   |
| High Frequency Driver          | 1" (25.4mm) Mylar               | 1" (25.4mm) Silk Dome              |
| Crossover frequency            | 2.3kHz                          | 2.3kHz                             |
| HF Protection                  | Pro-tech (PTC)                  | Pro-tech (PTC)                     |
| Input connectors               | Bare wire spring connector      | Bare wire spring connector         |
| Input connectors(T)            | Screw-down barrier strip        | Screw-down barrier strip           |
| Output Connectors              | NA                              | NA                                 |
| Cabinet Material               | MDF (Black Sandex vinyl)        | MDF (Black Sandex vinyl)           |
| Dimensions (H x W x D) (mm)    | 233.5 x 166 x 152               | 275 x 196 x 192                    |
| Weight per pair (kg)/T version | 4.5 kg(9.9lbs.)/5.12Kg(11.2lbs) | 6.2 kg (13.6 lbs.)/8.06Kg(17.7lbs) |
| Rigging                        | M6 x 4 (bracket inc.)           | M6 x 4 (bracket inc.)              |
| Transformer (T models)         | 100V only                       | 100V/ 70V                          |
| Transformer Tap(70V)           | NA                              | 5/10/20/40W                        |
| Transformer Tap(100V)          | 1.25/2.5/5/10W                  | 10/20/40W                          |

# Programme Series 30E/30ET/35E/35ET

## DIMENSIONS

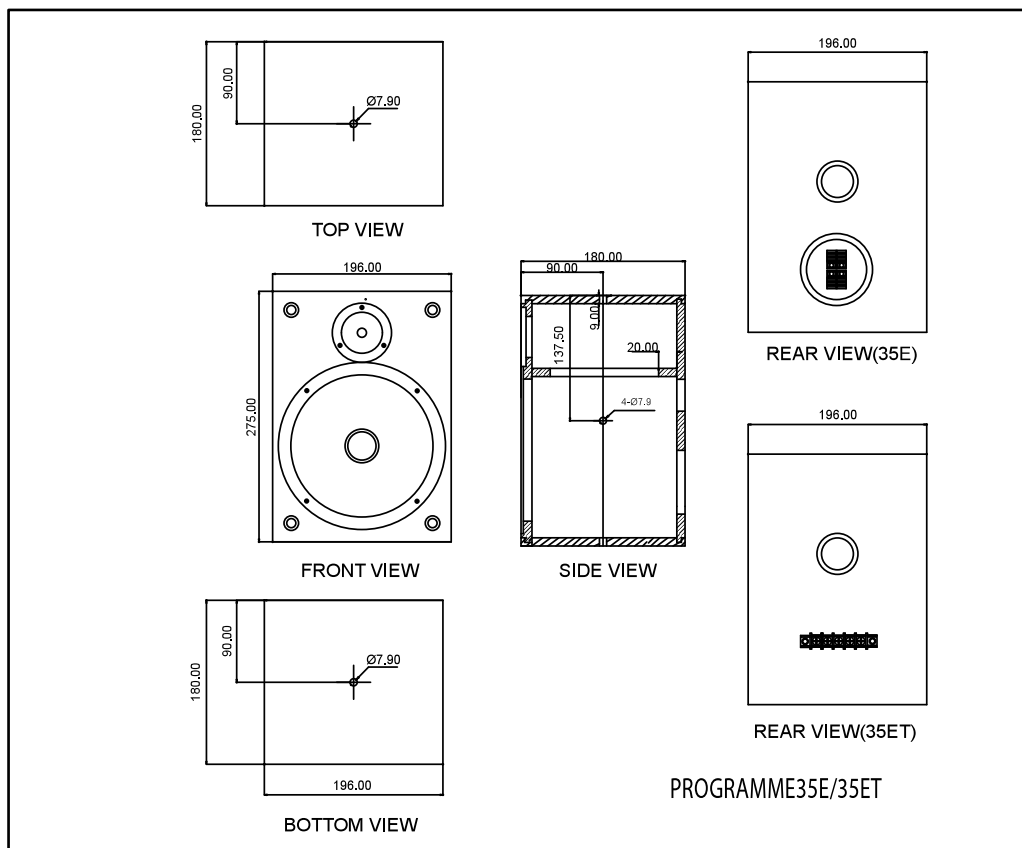
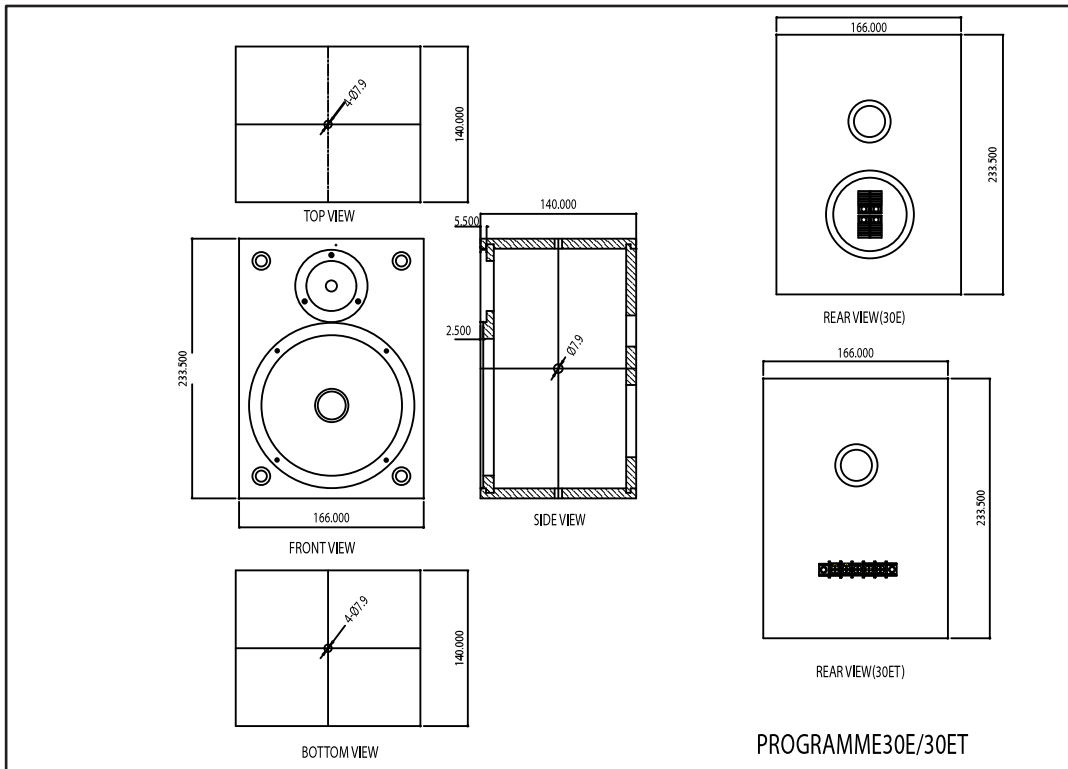

# Programme Series 30E/30ET/35E/35ET



## WHARFEDALE PRO LIMITED WARRANTY

Wharfedale **Programme 30E/30ET/35E/35ET** are warranted of manufacturing or material defects for a period of one year from the original date of purchase. In the event of malfunction, contact your authorized Wharfedale Pro dealer or distributor for information.

\*Be aware that warranty details may differ from country to country. Contact your dealers or distributor for information. These terms do not infringe your statutory rights.



Wharfedale International LTD.  
IAG HOUSE  
Sovereign Court, Ermine Business Park  
Huntingdon, Cambs,  
PE29 6XU, England

[www.wharfedalepro.com](http://www.wharfedalepro.com)

IAG Professional reserves the right to alter or improve  
specifications without notice  
All rights reserved © 2007 Wharfedale Pro  
Wharfedale Pro is a member of the International Audio Group (IAG)