

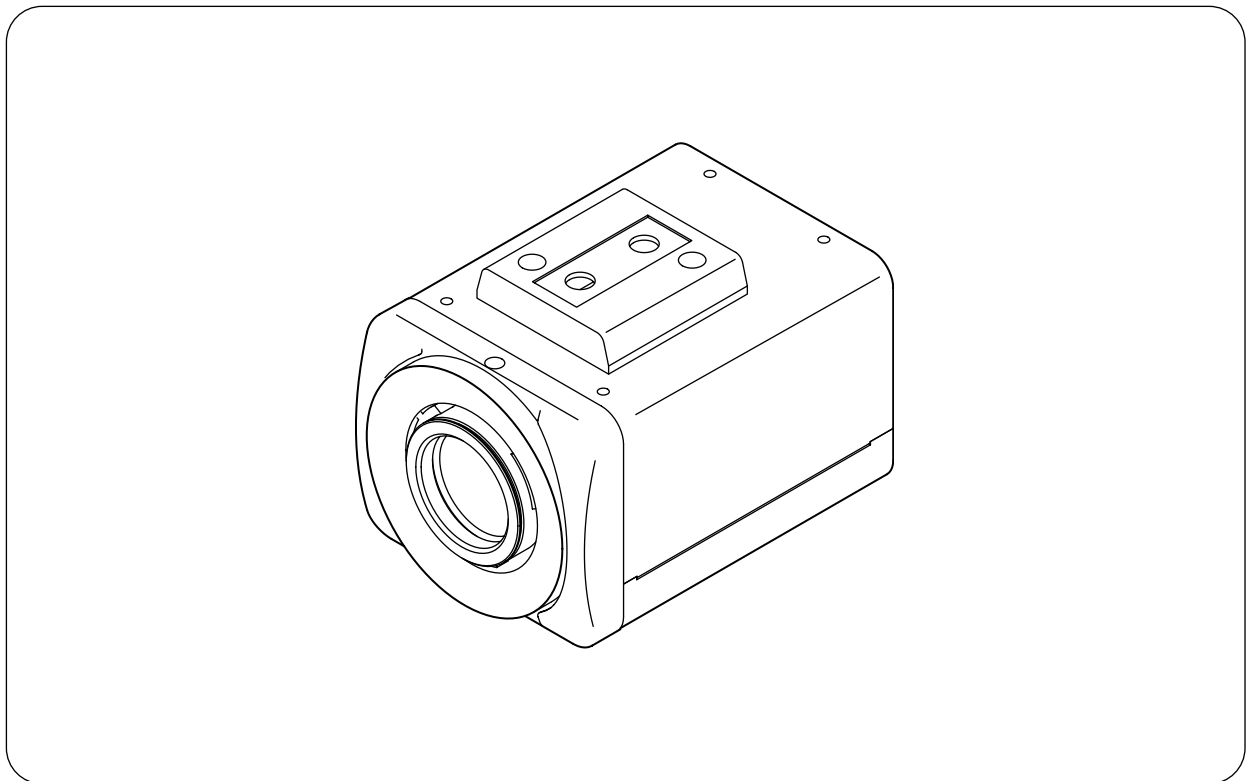

**INSTRUCTION MANUAL**

**COLOR CAMERA**

**C-CV14-CS NTSC**  
**C-CV14-CS PAL**



Thank you for purchasing TOA's Color Camera. Please carefully follow the instructions in this manual in order to ensure long, trouble-free use of your color camera.

**TOA Corporation**

# TABLE OF CONTENTS

<b>1. SAFETY PRECAUTIONS</b> .....	3
<b>2. GENERAL DESCRIPTION</b> .....	4
<b>3. HANDLING PRECAUTIONS</b> .....	4
<b>4. NOMENCLATURE</b> .....	5
<b>5. INSTALLATION</b> .....	6
<b>6. CONNECTIONS</b> .....	7
<b>7. ADJUSTMENT</b> .....	8
<b>8. ABOUT THE MODE SETTING SWITCH</b>	
8.1. Adjustment Switch .....	9
8.2. Backlight Compensation Switch .....	9
8.3. Shutter Speed Switch .....	9
<b>9. IF YOU THINK THERE IS A FAILURE: (TROUBLESHOOTING)</b> .....	10
<b>10. SPECIFICATIONS</b> .....	11
Optional Products .....	11

# 1. SAFETY PRECAUTIONS

- Before installation or use, be sure to carefully read all the instructions in this section in order to ensure long, trouble-free operation.
- Be sure to follow all the precautionary instructions in this section, which contain important warnings regarding safety.
- After reading, keep this manual handy for future reference.

## Safety Symbol and Message Conventions

Safety symbols and messages are used in this manual to prevent bodily injury and property damage which could result from mishandling. Before doing anything else, read this section first so you are thoroughly aware of the potential safety hazards as well as understanding the safety symbols and messages.



### WARNING

Do not expose the unit to rain or an environment where it may be splashed by water or other liquids, as doing otherwise may result in fire or electric shock.



### WARNING

Indicates a potentially hazardous situation which could result in death or serious personal injury if ignored or mishandled.

- Install the unit only in a location that can structurally support the weight of the unit and the mounting bracket. Doing otherwise may result in the unit falling and causing personal injury.
- Do not install the unit outdoors since it is designed for indoor use. If installed outdoors, the aging of parts causes the unit to fall down, possibly resulting in personal injury. Also, when it is exposed to rain, an electric shock may result.
- Should any of the following irregularities be found during use, immediately switch off the power, disconnect the power supply cord from the AC outlet and contact your TOA dealer. Do not attempt to further use the unit because a fire or electric shock may result.
  - If you detect smoke or a strange smell coming from the unit.
  - If water or a foreign object enters the unit.
  - If the unit falls or the unit case breaks.
  - If the power supply cord is damaged (exposure of core or disconnection).
  - If no image is displayed on the screen.
- Do not open nor modify the unit's case to prevent a fire or electric shock because there are high voltage components inside the unit. Refer all inspection, adjustment and repair work to the dealer from where the unit was purchased.
- Do not insert or drop metal pieces or flammable materials into the unit's ventilation slots as this may result in fire or electric shock.
- Have the unit periodically checked by the dealer from where it was purchased. Should the unit or its mounts corrode or structurally deteriorate, the unit could fall down, possibly resulting in personal injury.



### CAUTION

Indicates a potentially hazardous situation which could result in moderate or minor personal injury, and/or property damage if ignored or mishandled.

- Avoid installing the unit in humid or dusty locations, in locations exposed to the direct sunlight, near the heaters, or in locations generating sooty smoke or steam as doing otherwise may result in fire or electric shock.
- Leave the unit's installation to the dealer from where the unit was purchased because the installation requires expert knowledge. Inadequate installation may cause the unit to fall, possibly resulting in personal injury.
- Do not hang from the unit, as the unit may fall, possibly resulting in personal injury.

**Note**

This equipment has been tested and found to comply with the limits for a Class B digital device, pursuant to Part 15 of the FCC Rules. These limits are designed to provide reasonable protection against harmful interference in a residential installation. This equipment generates, uses and can radiate radio frequency energy and, if not installed and used in accordance with the instructions, may cause harmful interference to radio communications. However, there is no guarantee that interference will not occur in a particular installation. If this equipment does cause harmful interference to radio or television reception, which can be determined by turning the equipment off and on, the user is encouraged to try to correct the interference by one or more of the following measures:

- Reorient or relocate the receiving antenna.
- Increase the separation between the equipment and receiver.
- Connect the equipment into an outlet on a circuit different from that to which the receiver is connected.
- Consult the dealer or an experienced radio/ TV technician for help.

**Modifications**

Any modifications made to this device that are not approved by TOA Corporation may void the authority granted to the user by the FCC to operate this equipment.

Underwriters Laboratories Inc. (UL) has not tested the performance or reliability of the security aspects of this product. UL has only tested for fire, shock or casualties as outlined in UL's Standard(s) for Safety. UL Certification does not cover the performance or reliability of the security hardware and security operating software. UL MAKES NO REPRESENTATIONS, WARRANTIES OR CERTIFICATIONS WHATSOEVER REGARDING THE PERFORMANCE OR RELIABILITY OF ANY SECURITY RELATED FUNCTIONS OF THIS PRODUCT.

## 2. GENERAL DESCRIPTION

The C-CV14-CS Color Camera is a high-resolution surveillance camera equipped with a 1/4" CCD. It is designed to operate on 24V AC or 12V DC. The CS mount permits the optional lens that is the most appropriate for each application to be selected.

## 3. HANDLING PRECAUTIONS

- Do not point the camera toward the sun or other strong lighting or reflected light.
- Avoid jarring or striking the camera, as the camera may fail.
- Install the camera in locations where the temperature range does not exceed  $-10^{\circ}\text{C}$  to  $+50^{\circ}\text{C}$ , and no dew condensation is formed.
- To clean, wipe with a soft, dry cloth. Never use benzene, thinner or chemically-treated towel to avoid damage to the camera's finish.
- To clean the lens, use a camera blower or lightly wipe with lens cleaning paper.
- Picture quality may suffer if camera cables are wired close to other electrical equipment, such as fluorescent lamps. In such cases, reroute the wiring.
- Monitor screen pictures may become distorted or roll if the camera is used in locations influenced by strong electrical or magnetic fields from television transmission antennas, motors or transformers. In such cases, install the cables inside sheet steel cable conduit.
- Use the external power supply unit of the following rating when the camera is operated on 12 V DC.  
12 V DC, over 1.0 A

## 4. NOMENCLATURE

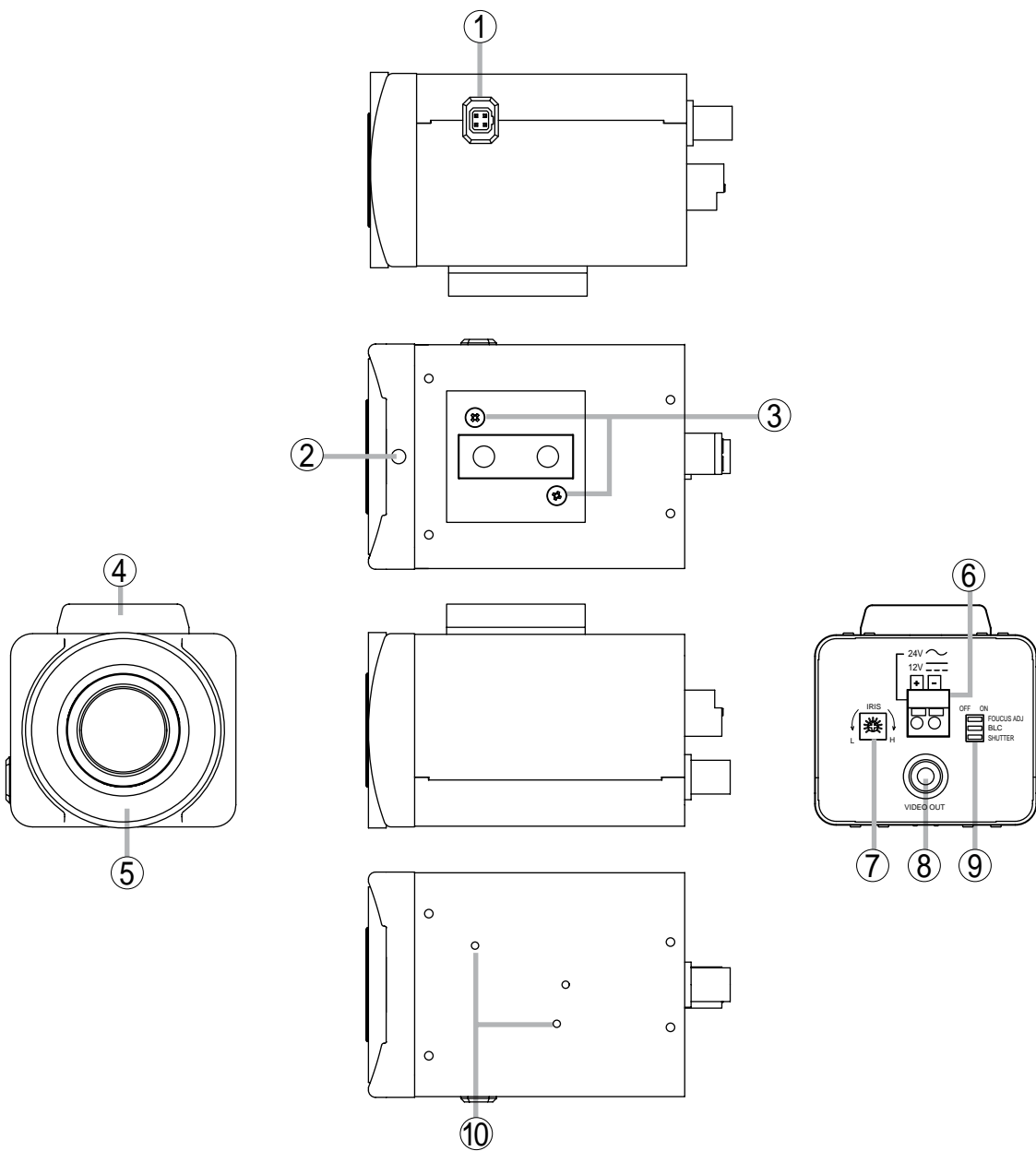

**(1) Lens connector**

**(2) Back focal length adjustment ring fixing screw**

**(3) Camera mount fixing screw**

**(4) Camera mount**

**(5) Back focal length adjustment ring**

**(6) Power input terminal  
(24 V AC or 12 V DC)**

**(7) Iris control**

**(8) Video output terminal (BNC)**

**(9) Mode setting switch**

**(10) Camera mount fixing hole**

**Note**

Fixing holes (10) are provided in both the top and bottom panels.

# 5. INSTALLATION

[Ceiling mounting example]

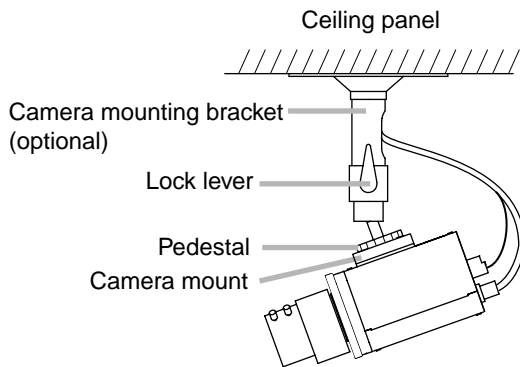

[Wall mounting example]

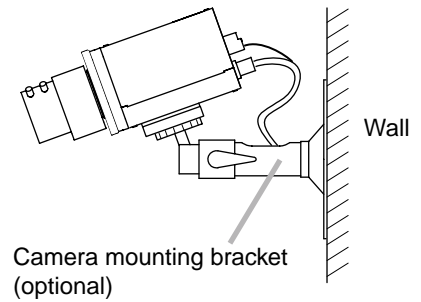

**⚠ WARNING**  
 Install the unit only in a location that can structurally support the weight of the unit and the mounting bracket. Doing otherwise may result in the unit falling down and causing personal injury.

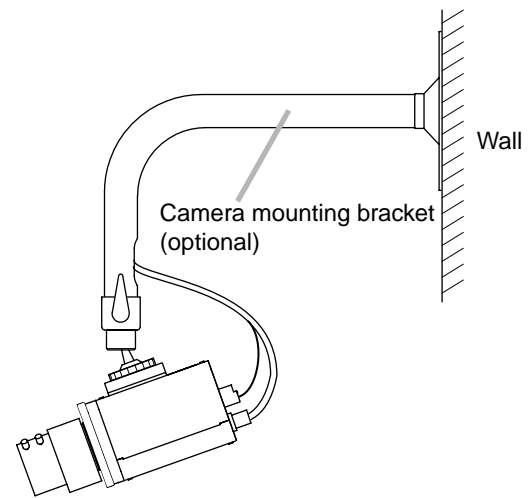

1. Attach the lens to the camera.
- Insert the lens into the camera's lens mount and rotate to full stop.
  - Connect the connector from the lens to the lens connector.

**Note**  
 DC drive type lenses can be used, however Video type lenses cannot be used.

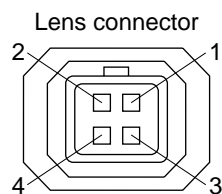
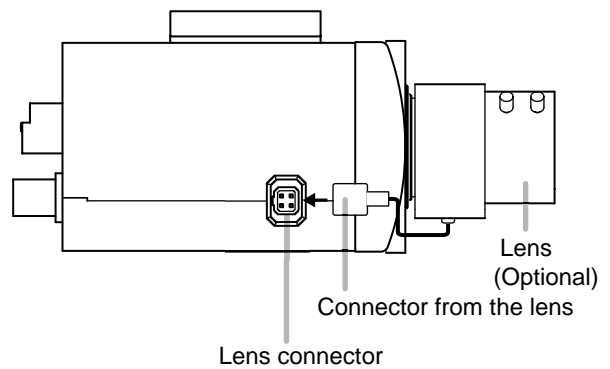

Pin No.	Pin name
1	Damping coil ⊖
2	Damping coil ⊕
3	Driving coil ⊕
4	Driving coil ⊖

## Notes

- To avoid damaging the internal sections of the camera's lens mount, be sure that the lens flange is less than 5 mm thick as illustrated on the right.
- C-mount lenses must be used in conjunction with the Lens Mounting Adapter CF-5 (optional).
- When used 1/3 type lens, an angle of view becomes narrow.

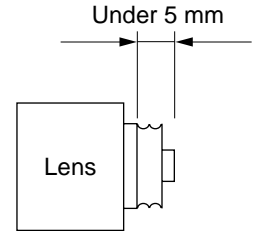

2. Mount the optional camera mounting bracket to a ceiling or wall.  
Using an electrical box, fix the camera mounting bracket with its supplied screws. Run the coaxial cable through the hole in the bracket.
3. Set the camera mounting bracket securely in the threaded hole in the camera mount rotating the bracket's pedestal.

## Notes

- The camera mount can be mounted to both the top and bottom of the camera. Attach the bracket to either side depending on installation conditions.
  - Use the camera mount fixing screw to attach or detach the camera mount.
4. Set the camera orientation, and secure the camera.  
After setting the camera orientation, rotate the lock lever to secure the camera.

## 6. CONNECTIONS

**Note:** If the Video output is not terminated at 75  $\Omega$ , video pictures are not properly displayed. Make sure that the output has been terminated at 75  $\Omega$  at the connected monitor or switcher.

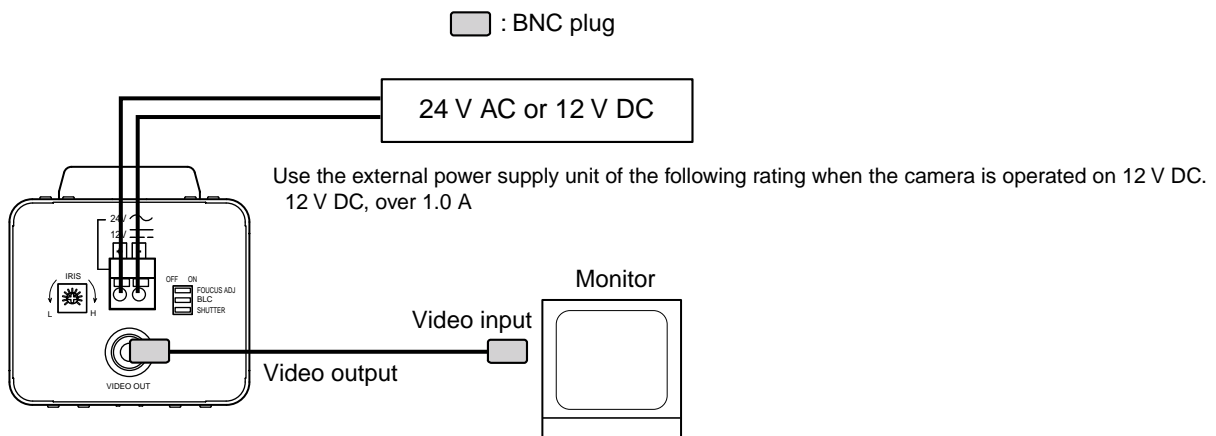

## 7. ADJUSTMENT

1. Switch on the camera power after completing camera connections.  
Power is supplied to the camera.
2. Normally, set the Shutter Speed switch to "1/60"(NTSC) or "1/50"(PAL) position.  
Flickering of the picture may interfere with the view under fluorescent lamp in the area with power frequency of 50 Hz(NTSC) or 1/60 Hz(PAL). In such cases, set the switch to "1/100"(NTSC) or "1/120"(PAL) position, and the image free from flickering can be obtained.

### Note

If the Shutter Speed switch of the Mode Setting switch is set to the ON position, sensitivity is reduced compared to operation in the OFF position. When using the camera in a dark location, or where light flicker is not an annoyance, set the switch to the OFF position.

3. Connect the monitor to the Video Output terminal to permit a picture to be viewed on the monitor.
4. Adjust the camera angle.  
Loosen the camera mounting bracket's lock lever to point the camera to the desired direction, then retighten the lock lever to fix the camera securely.
5. Adjust the angle of view with the Zoom ring and adjust the focus with the Focus ring for the best possible picture reproduction.

### Notes

- Since the Iris control (for sensitivity adjustment) is factory-preset to an optimum position for general use, avoid tampering with it in normal conditions. Turning the control unnecessarily could cause reduced picture quality or equipment failure. When the Iris control needs to be readjusted to match a specific subject, first set both the Adjustment switch and the Backlight Compensation switch of the Mode setting switch to the OFF position, then adjust the control to an optimum level. After adjustment, place a hand over the lens for several seconds and then release to check the lens for correct iris operation.
- If the focus is adjusted for a subject under good lighting conditions, the subject may go out of focus when conditions become dark. To avoid this, adjust the lens focus after setting the Adjustment switch of the Mode setting switch to the ON position. Be sure to switch it back to the OFF position after completing lens adjustment.
- When a subject appears out of focus because it is closer than the lens' minimum close-up distance, adjust the focus as follows:  
(Back focal length adjustment)  
(1) Attach the lens.  
(2) Loosen the Back focal length adjustment ring fixing screw.  
(3) Rotate the Back focal length adjustment ring to set it to an optimum position.  
(4) Retighten the Back focal length adjustment ring fixing screw.

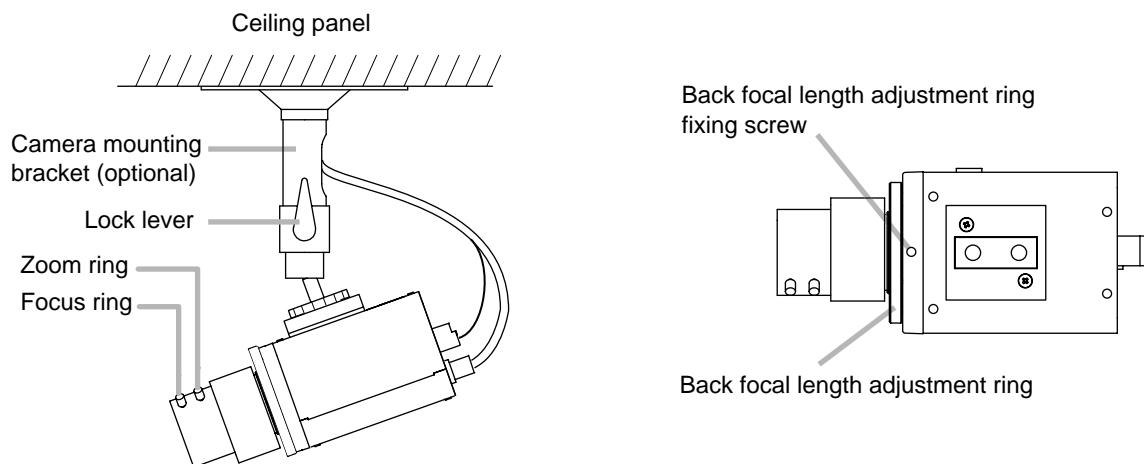



## 8. ABOUT THE MODE SETTING SWITCH

Set the Mode Setting switch for the best possible picture reproduction depending on installation conditions.

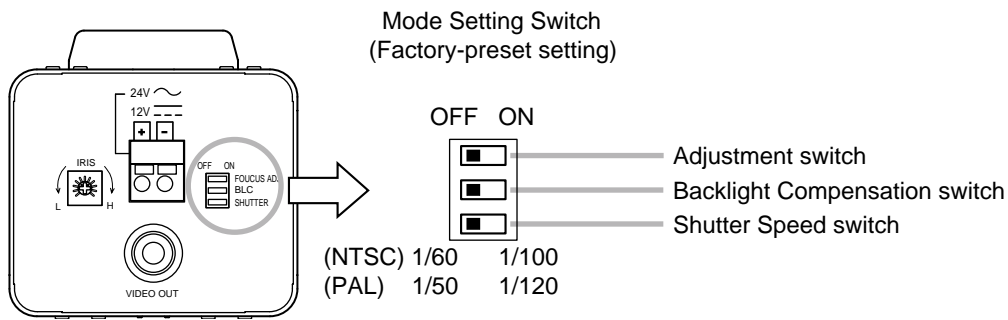

### 8.1. Adjustment Switch

Set this switch when adjusting the lens focus. (Provides the same effect as when using the ND filter.)

OFF ON

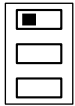

Standard position :

Set to OFF after lens adjustment completion. Set to this position during normal use.

OFF ON

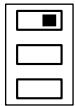

Adjustment position (during adjustment) :

Use this position when focusing the lens. If the focus is adjusted for a subject under good lighting conditions, the subject may go out of focus when conditions become dark. Set the Adjustment switch to ON only when performing focus adjustment.

**Note:** The color of the screen may periodically vary under fluorescent lighting when the Adjustment switch is set to ON.

### 8.2. Backlight Compensation Switch

Set this switch so that the subject is not displayed in black when backlit.

OFF ON

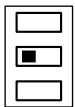

Standard position :

Set to this position during normal use. Backlight Compensation function does not operate when the switch is set to this position.

OFF ON

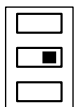

Backlight Compensation position (when backlit) :

This position prevents images from being displayed in black when the image is backlit.

### 8.3. Shutter Speed Switch

Set this switch to the ON position when annoying screen image flicker is detected.

OFF ON

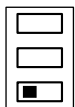

Standard position :

Set to this position during normal use.

OFF ON

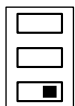

Shutter Speed position :

Annoying screen flicker may result under fluorescent lighting in areas operating with a power frequency of 50 Hz (NTSC) or 60 Hz (PAL). In such cases, set the Shutter Speed switch to the ON position to permit a flicker-free picture to be viewed.

**Note:** If the Shutter Speed switch is set to the ON position, sensitivity is reduced compared to operation in the OFF position. When using the camera in a dark location, or where light flicker is not an annoyance, set the switch to the OFF position.

## 9. IF YOU THINK THERE IS A FAILURE: (TROUBLESHOOTING)

Symptom	Possible Cause	Remedy
Camera images are not displayed on the monitor.	<ul style="list-style-type: none"> <li>• The monitor's power switch is not set to ON.</li> <li>• Cables are not correctly connected.</li> <li>• The BNC plug is not correctly soldered.</li> <li>• Power is not supplied to the camera.</li> </ul>	<ul style="list-style-type: none"> <li>• Turn on the power switch.</li> <li>• Connect correctly.</li> <li>• Solder correctly.</li> <li>• Switch on the power.</li> </ul>
Pictures are not clear.	<ul style="list-style-type: none"> <li>• The lens is not properly focused.</li> <li>• The lens is dirty.</li> <li>• Monitor image black level is not correctly adjusted.</li> </ul>	<ul style="list-style-type: none"> <li>• Adjust the lens.</li> <li>• Wipe the lens.</li> <li>• Adjust the level correctly.</li> </ul>
The color of the picture periodically varies.	<ul style="list-style-type: none"> <li>• The Adjustment switch is set to the ON position.</li> </ul>	<ul style="list-style-type: none"> <li>• Set the Adjustment switch to the OFF position.</li> </ul>

## 10. SPECIFICATIONS

Model No.	C-CV14-CS (NTSC)	C-CV14-CS (PAL)
Power Source	24 V AC, 50/60 Hz, or 12 V DC	
Power Consumption	2 W	
Image Device	1/4" IT-CCD	
Number of Effective Pixels	768 (H) x 494 (V), 380,000 pixels	752 (H) x 582 (V), 440,000 pixels
Scanning System	2:1 interlace	
Scanning Frequency	15.734 kHz (H), 59.94 Hz (V)	15.625 kHz (H), 50 Hz (V)
Video Output	VBS1.0 V(p-p), 75 Ω, BNC connector	
Synchronizing System	Internal synchronization	
Resolution	H: 480 lines (center), V: 350 lines	H: 470 lines (center), V: 410 lines
S/N Ratio	48 dB	
Minimum Illumination	3 lx (F:1.4, 50 IRE)	3 lx (F:1.4, 350 mV)
White Balance Mode	ATW	
Lens Mount	CS mount	
Auto-Iris Lens Output	DC drive type (4 pin connector)	
Control Switch	ON/ OFF (for focus adjustment)	
Other Functions	Backlight compensation, Shutter speed, iris control	
Shutter Speed	1/60, 1/100	1/50, 1/120
Operating Temperature	- 10°C to + 50°C	
Operating Humidity	Under 90% RH (no dew condensation)	
Finish	Case : Surface-treated steel plate, light gray, paint Front cover : Aluminum, light gray, paint	
Dimensions	63.4 (W) x 62.7 (H) x 102.5 (D) mm	
Weight	300 g	

The specifications of this camera are subject to change without notice.

### • Optional Products

Camera mounting bracket

