

KORG

TP-2

Dual Tube Preamp w/Optical Compression and Digital Output



Owner's Manual

Ⓔ ①

KORG INC. 4015-2 Yanokuchi, Inagi-city, Tokyo 206-0812 Japan

© 2004 KORG INC.

1508 CTH Printed in Japan

Precautions

Location

Using the unit in the following locations can result in a malfunction.

- In direct sunlight
- Locations of extreme temperature or humidity
- Excessively dusty or dirty locations
- Locations of excessive vibration
- Close to magnetic fields

Power supply

Please connect the designated AC/AC power supply to an AC outlet of the correct voltage. Do not connect it to an AC outlet of voltage other than that for which your unit is intended.

Interference with other electrical devices

Radios and televisions placed nearby may experience reception interference. Operate this unit at a suitable distance from radios and televisions.

Handling

To avoid breakage, do not apply excessive force to the switches or controls.

Care

If the exterior becomes dirty, wipe it with a clean, dry cloth. Do not use liquid cleaners such as benzene or thinner, or cleaning compounds or flammable polishes.

Keep this manual

After reading this manual, please keep it for later reference.

Keeping foreign matter out of your equipment

Never set any container with liquid in it near this equipment. If liquid gets into the equipment, it could cause a breakdown, fire, or electrical shock. Be careful not to let metal objects get into the equipment. If something does slip into the equipment, unplug the AC/AC power supply from the wall outlet. Then contact your nearest Korg dealer or the store where the equipment was purchased.

THE FCC REGULATION WARNING (for U.S.A.)

This equipment has been tested and found to comply with the limits for a Class B digital device, pursuant to Part 15 of the FCC Rules. These limits are designed to provide reasonable protection against harmful interference in a residential installation. This equipment generates, uses, and can radiate radio frequency energy and, if not installed and used in accordance with the instructions, may cause harmful interference to radio communications. However, there is no guarantee that interference will not occur in a particular installation. If this equipment does cause harmful interference to radio or television reception, which can be determined by turning the equipment off and on, the user is encouraged to try to correct the interference by one or more of the following measures:

- Reorient or relocate the receiving antenna.
- Increase the separation between the equipment and receiver.
- Connect the equipment into an outlet on a circuit different from that to which the receiver is connected.
- Consult the dealer or an experienced radio/TV technician for help.
- Unauthorized changes or modification to this system can void the user's authority to operate this equipment.

CE mark for European Harmonized Standards

CE mark which is attached to our company's products of AC mains operated apparatus until December 31, 1996 means it conforms to EMC Directive (89/336/EEC) and CE mark Directive (93/68/EEC). And, CE mark which is attached after January 1, 1997 means it conforms to EMC Directive (89/336/EEC), CE mark Directive (93/68/EEC) and Low Voltage Directive (73/23/EEC).

Also, CE mark which is attached to our company's products of Battery operated apparatus means it conforms to EMC Directive (89/336/EEC) and CE mark Directive (93/68/EEC).

IMPORTANT NOTICE TO CONSUMERS

This product has been manufactured according to strict specifications and voltage requirements that are applicable in the country in which it is intended that this product should be used. If you have purchased this product via the internet, through mail order, and/or via a telephone sale, you must verify that this product is intended to be used in the country in which you reside.

WARNING: Use of this product in any country other than that for which it is intended could be dangerous and could invalidate the manufacturer's or distributor's warranty.

Please also retain your receipt as proof of purchase otherwise your product may be disqualified from the manufacturer's or distributor's warranty.

Specifications

Input connectors: XLR-3-31 type (+48 V phantom power, switchable), 1/4" TRS phone jack (balanced / unbalanced is Hi-Z)

Input impedance: 4 k (XLR-3-31), 10 k (TRS phone Jacks), 1 M (TRS phone Jacks is Hi-Z)

Nominal level: -60 dBu to -12 dBu @ TRIM=max. — min PAD OFF
-34 dBu to +14 dBu @ TRIM=max. — min PAD ON

Maximum level: -48 dBu to 0 dBu @ TRIM=max. — min PAD OFF
-22 dBu to +26 dBu @ TRIM=max. — min PAD ON

Hi-Z
- 48 dBu to 0 dBu @ TRIM=max. — min PAD OFF
- 22 dBu to +12 dBu @ TRIM=max. — min PAD ON

Source impedance: 600

Vacuum tubes used: 12AX7

Compression method: Vacuum tube compression using a photocoupler

Principal specifications

Frequency response:
10 Hz - 44 kHz ± 1 dB @ output +4 dBu, 10 k load

S/N: 85 dB (typical)

A/D conversion: 24-bit 64 times oversampling

Sampling frequency: 44.1kHz, 48kHz, 96kHz

Analog output

Connectors: XLR-3-32 type, 1/4" TRS phone jack (balanced)

Output impedance: 150

Nominal level: +4 dBu

Maximum level: +16 dBu

Source impedance: 10k or higher

Digital output

Connectors: optical, coaxial

Format: 24bit S/P DIF (IEC60958 / EIAJ CP-1201)

General

Power supply: Included AC/AC power supply

Dimensions:
224(W) x 170(D) x 88(H)mm / 8.82"(W) x 6.69"(D) x 3.46"(H)
(including protrusions)

Weight: 1.33 kg / 2.93 lbs

Included items

AC/AC power supply, Owner's manual

Block diagram

TP-2 [Tube Preamp]

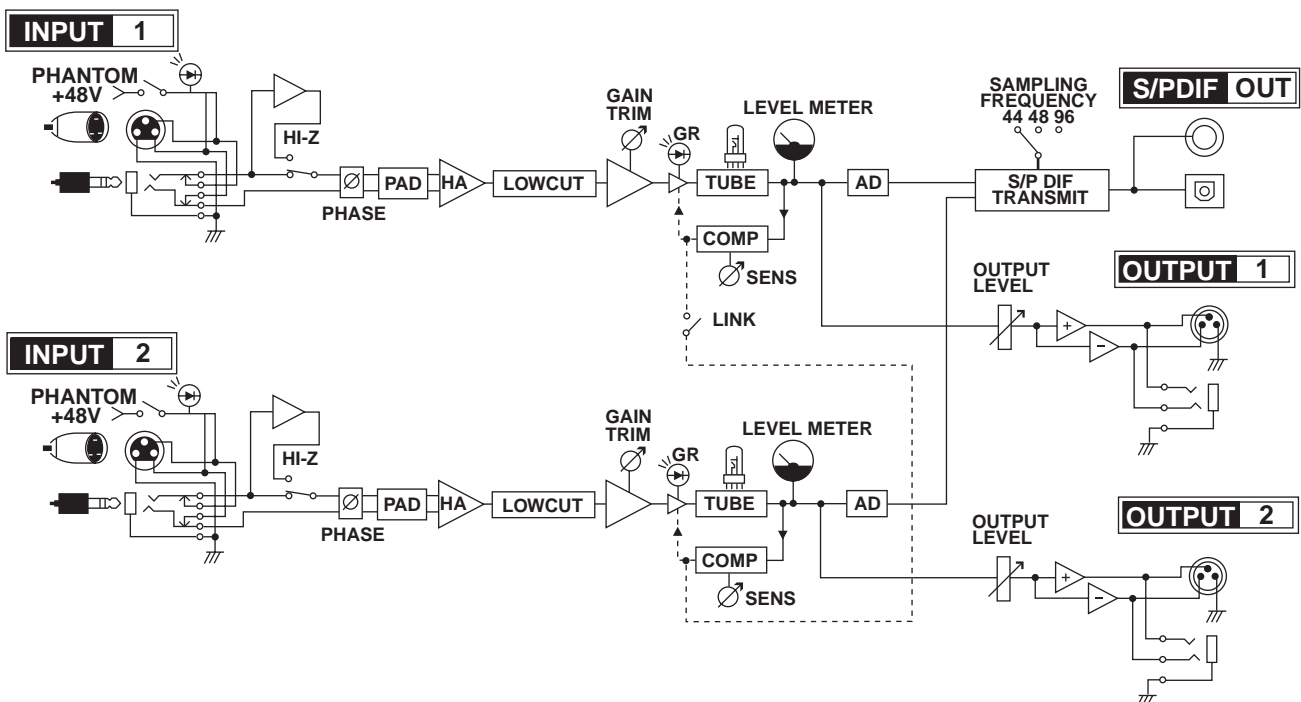

Introduction

Thank you for purchasing the **Korg TP-2 Dual Tube Preamp w/ Optical Compression and Digital Output**. In order to enjoy long and trouble-free use, please read this owner's manual carefully, and use your **TP-2** only as directed.

Features

The **TP-2** is a dual-channel preamp featuring two 12AX7 vacuum tubes, plus fast operating and transparent optical compression and limiting circuitry. Designed to accept a variety of sources over a wide range of levels, it is ideal for your most critical and demanding recording applications.

In addition to both XLR and 1/4" TRS balanced outputs, the **TP-2** also features both optical and coaxial digital outputs (S/P DIF format) allowing it to interface with other digital equipment, or to serve as a stand alone AD converter.

Using a specially tuned version of our acclaimed Valve Force circuit, the **TP-2** delivers the robust, musical warmth and mid-low region presence typical of vacuum tubes. The optical compression responds quickly and transparently, providing a distinctly full analog body without adversely coloring the sound. In addition, the optical compressor's gain reduction and limiting circuitry allow you to avoid any audio clipping while you're recording.

1. Parts and their function

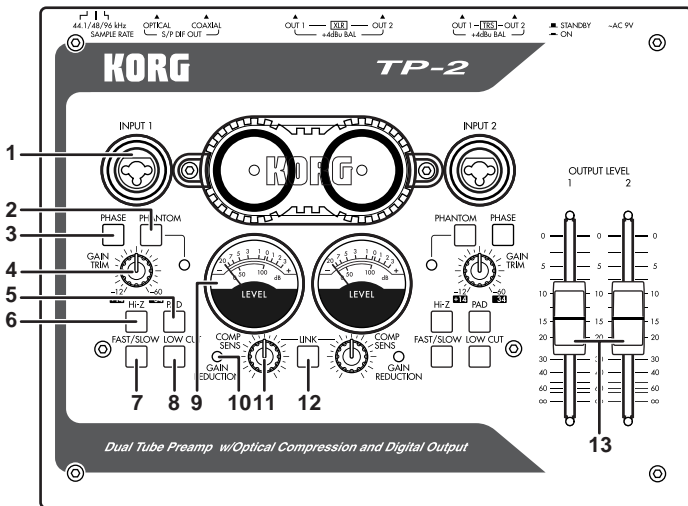
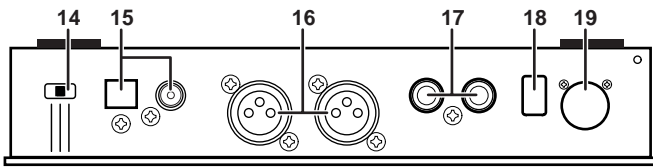

1. INPUT 1, INPUT 2 jacks

These are balanced inputs that combine XLR jacks and 1/4" TRS phone jacks. Unbalanced phone plugs may also be connected to the 1/4" jacks. If you are using a condenser mic requiring phantom power, connect it to the XLR jack.

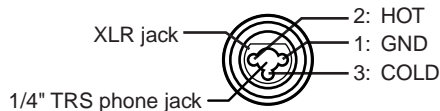

If you are using a guitar or the line output from an instrument, connect it to the TRS phone jack.

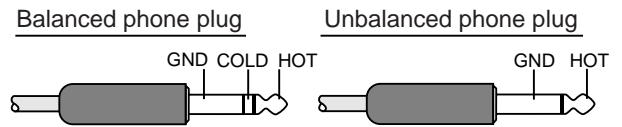

2. Phantom power switch/LED

This switch supplies +48V phantom power to condenser mics. The LED will light if +48V power is being supplied. Power is supplied only to the XLR jack. Turn this off (LED dark) if you're using a dynamic mic.

⚠ If a condenser mic is connected or disconnected with the phantom power switch on, damage to your equipment may occur. For this reason, always turn the phantom power switch off before connecting or disconnecting a condenser mic.

3. Phase switch

If you are inputting a stereo source from audio equipment in which the hot and cold pins are wired in reverse, the stereo image may be unsteady or cancellation may occur. By pressing this switch in, you can invert the phase of the input signal by 180 degrees to compensate.

4. Gain trim knob

This knob adjusts the input gain. If the PAD switch is on (pushed in), the range is +14 – -34 dBu. If the PAD switch is off, the range is -12 – -60 dBu.

5. Hi-Z switch

This switch changes the impedance level of the TRS phone jack to high impedance. It is on when the switch is pushed in. Turn this switch on when connecting a high output impedance device such as guitar or bass.

6. PAD switch

This switch lowers the level of the input signal by 26 dB. The pad is on when the switch is pushed in. When a line level input source is connected, turning the pad on will allow the gain trim knob to have a wider useful range of adjustment.

7. Compressor mode switch

This switch changes the compressor's response speed. Use the Fast setting for short sounds such as drums or percussion, and the Slow setting (press the switch in) for more sustained sounds, such as vocals.

8. Low cut switch

This switch activates a 70 Hz -6 dB/oct low cut filter. Use this to reduce unwanted low-frequency content. The filter is on when the switch is pressed in.

9. Level meter

The meter shows the audio level. If the needle moves into the red area above 0 dB, this indicates that digital clipping is occurring. Set the gain trim knob and the compressor sensitivity knob to prevent the needle from exceeding 0 dB.

⚠ Place the unit horizontally so that the level meters operate correctly.

⚠ The level meters indicate the level of the signal before it is sent to the output level faders.

10. Gain reduction LED

This LED will light when gain reduction is being applied by the compressor.

11. Compressor sensitivity knob

This specifies the audio level where the compressor begins to kick in. Turning the knob toward the right will increase the sensitivity, so that compression will be applied even at low levels.

If you don't want to apply compression, turn this knob all the way to the left.

12. Link switch

Press this switch in to link the two channels together for use with stereo sources. When linked, compression will be applied equally to both channels whenever either channel exceeds the compressor's sensitivity threshold, preserving the stereo imaging.

13. Output level fader

This adjusts the output level.

 When the fader is at the 0 dB position, the meter level will match the output level.

14. Sampling frequency select switch

This switch selects the sampling frequency of the S/P DIF output. You can choose from 44.1 kHz, 48 kHz, and 96 kHz.

15. S/P DIF output (optical, coaxial)

An optical jack and a coaxial jack (IEC 60958, EIAJ CP-1201) both provide a S/P DIF format digital output. Connect the digital output to the digital input jack of your other equipment.

16. Analog output jack (XLR)

This is a balanced output jack using an XLR connector.

17. Analog output jack (TRS)

This is a balance output jack using a TRS phone jack.

18. Power switch

This is the power switch. Press it in to turn the power on. Pressing it again will turn the power off and return the switch to the out position.

19. AC9V connector

Connect the included AC/AC power supply here.

2. Operation

2-1. Connections

 First connect the AC/AC power supply to the TP-2's AC9V connector, and then plug it into an electrical outlet.

Start by connecting your external equipment.

Connect the AC/AC power supply. If you will be using the digital output, set the sampling frequency select switch to the correct frequency for your other gear, and then turn on the power.

note Before turning on the power, set the output level faders to – so that sudden loud noise does not occur.

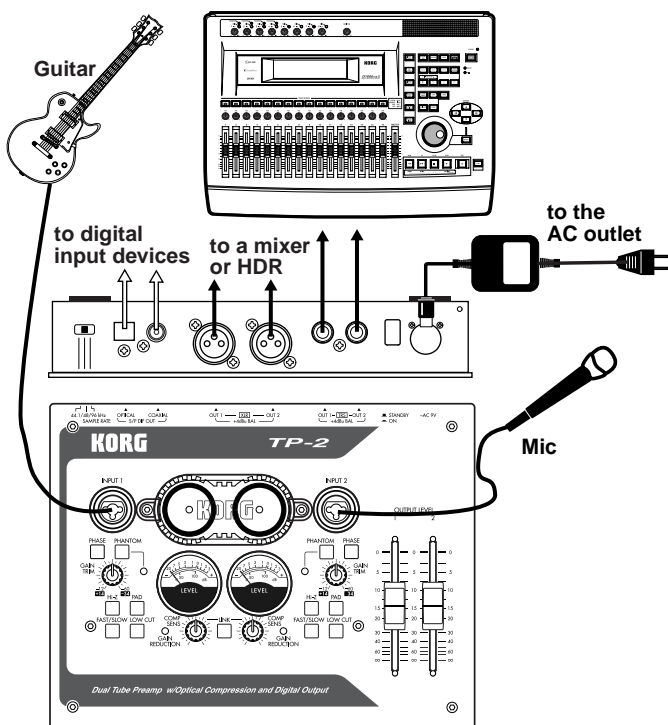

2-2. Adjusting the input level

When you've finished making your connections, watch the TP-2's level meter while you use the gain trim knob to adjust the level. Set the trim knob so that the level meter needle does not exceed 0 dB when the loudest sound is input.

If the level meter goes beyond 0 dB even when the gain trim knob is turned all the way toward the left, press the PAD switch and then use the gain trim knob to adjust the level.

note Normally if the needle goes beyond 0 dB, digital clipping has occurred, causing distortion. You should set the level so that it does not exceed 0 dB.

2-3. Using the compressor

Turn the compressor sensitivity knob all the way to the left so that the compressor is not being applied.

Use the gain trim knob to raise the level so that the meter slightly exceeds 0 dB during the loudest input passages.

Slowly turn the compressor sensitivity knob toward the right. The gain reduction LED will begin to light, indicating that the compressor is being applied.

While watching the level meter, continue turning the compressor sensitivity knob until the level does not exceed 0 dB during the loudest input passages.

If you want to apply a lot of compression to intentionally "squash" a vocal, use the gain trim knob to raise the input level further, and turn the compressor sensitivity knob toward the right to increase the compression.

note By using the gain trim knob to raise the preamp level appropriately, you can saturate the vacuum tube, generating analog overtones to enrich the sound in conjunction with the compressor.

2-4. Using the link switch

Turn on the link switch if you want to use stereo compression.

When you're recording a stereo source, and the level of one channel rises to the point where compression is being applied to only that one channel, then the relative volume of the other channel will increase, producing the impression that the stereo image has shifted to one side. In such cases, turning on the link switch will automatically apply compression to both channels at the same time, whenever either channel reaches the compressor's threshold level.

So that the compressors for both channels will function in the same way, select the same compressor mode setting for both channels (either Fast or Slow). You should also set the compressor sensitivity knob to about the same setting for both channels.

3. A note about the vacuum tubes

This device contains vacuum tubes. We recommend that you allow the tubes to warm up for about ten minutes after you turn on the power, before you begin running any audio signals through the TP-2.

If you begin using this device immediately after turning on the power, this may cause malfunctions and/or shorten the life of the vacuum tubes.

In order to maximize reliability, avoid placing this device above or below heat-producing equipment such as a power amp.

 Do not attempt to remove, replace or change the tubes in the TP-2. The tubes are not a user serviceable part.

 Vacuum tubes generate heat. Do not allow your skin to contact the vacuum tube cover for an extended period of time. Doing so can cause low-temperature burns.