

OPERATION AND PARTS MANUAL

STOW

A DIVISION OF MULTIQUIP INC.

PLASTER/MORTAR MIXER

MS15H5.5 (Steel-Gasoline)

MS15E (Steel-Electric)

Effective S/N SED53

FINAL REVISION

Revision #2 (08/10/06)

**THIS MANUAL MUST ACCOMPANY
THE EQUIPMENT AT ALL TIMES.**



WARNING



CALIFORNIA — Proposition 65 Warning

Engine exhaust and some of its constituents, and some dust created by power sanding, sawing, grinding, drilling and other construction activities contains chemicals known to the State of California to cause cancer, birth defects and other reproductive harm. Some examples of these chemicals are:

- Lead from lead-based paints.
- Crystalline silica from bricks.
- Cement and other masonry products.
- Arsenic and chromium from chemically treated lumber.

Your risk from these exposures varies, depending on how often you do this type of work. To reduce your exposure to these chemicals: **ALWAYS** work in a well ventilated area, and work with approved safety equipment, such as dust masks that are specially designed to filter out microscopic particles.

HERE'S HOW TO GET HELP

PLEASE HAVE THE MODEL AND SERIAL
NUMBER *ON-HAND* WHEN CALLING

STOW MAIN OFFICE

Post Office Box 6254
Carson, Ca 90749
Email: stow@multiquip.com
Internet: www.stowmfg.com

888-252-STOW
FAX: 310-537-1986

PARTS DEPARTMENT

800-427-1244
310-537-3700

FAX: 800-672-7877
FAX: 310-637-3284

SERVICE DEPARTMENT

800-421-1244
310-537-3700

FAX: 310-537-4259

TECHNICAL ASSISTANCE

800-478-1244

FAX: 310-631-5032

WARRANTY DEPARTMENT

800-421-1244, EXT. 279
310-537-3700, EXT. 279

FAX: 310-537-1173

SALES DEPARTMENT

310-661-4242
877-289-7869 (877-BUY-STOW)

FAX: 310-604-9237

© COPYRIGHT 2004, STOW CONSTRUCTION EQUIPMENT

STOW Construction Equipment and the STOW logo are registered trademarks of STOW and may not be used, reproduced, or altered without written permission. All other trademarks are the property of their respective owners and used with permission.

This manual MUST accompany the equipment at all times. This manual is considered a permanent part of the equipment and should remain with the unit if resold.

The information and specifications included in this publication were in effect at the time of approval for printing. Illustrations are based on the *MS-15H/MS15E Plaster/Mortar Mixer*. STOW Construction Equipment reserves the right to discontinue or change specifications, design or the information published in this publication at any time without notice and without incurring any obligations.

To find the latest revision of this
publication, visit our website at:
www.stowmfg.com



MS15H/MS15E Plaster/ Mortar Mixer

Here's How To Get Help	3
Table Of Contents	4
Parts Ordering Procedures	5
Specifications	6
Dimensions	7
Safety Messages Alert Symbols	8-9
Rules For Safe Operation	10-12
Operation and Safety Decals	13
General Information	14
Mixer Components	15
Engine Components	16
Electric Motor	17-18
Paddle Blade Adjustment	19
Inspection	20-21
Start-up Procedures	22-23
Shutdown Procedures	23
Maintenance (Engine)	24
Maintenance (Mixer)	25-26
Troubleshooting (Engine)	27-28
Troubleshooting (Mixer/Electric Motor)	29
Electric Motor Wiring Diagram	30
Explanation of Code In Remarks Column	32
Suggested Spare Parts	33

Component Drawings

Nameplate and Decals	34-35
Steel Tub Assembly	36-37
Paddle Shaft Assembly	38-39
Frame Assembly	40-41
Engine Cover Assembly	42-43
Honda Engine Assembly	44-45
Electric Motor Assembly	46-47

HONDA GX160K1HX2 ENGINE

Cylinder Head Assembly	48-49
Cylinder Barrel Assembly	50-51
Crankcase Cover Assembly	52-53
Crankshaft Assembly	54-55
Piston Assembly	56-57
Camshaft Assembly	58-59
Recoil Starter Assembly	60-61
Fan Cover Assembly	62-63
Carburetor Assembly	64-65
Air Cleaner Assembly	66-67
Muffler Assembly	68-69
Fuel Tank Assembly	70-71
Flywheel Assembly	72-73
Ignition Coil Assembly	74-75
Control Assembly	76-77
Gear Reduction Assembly	78-79
Labels	81-82

Terms and Conditions Of Sale — Parts	83
--	----

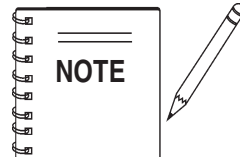

**Specification and part number
are subject to change without
notice.**

MS15H/MS15E MIXER — PARTS ORDERING PROCEDURES

When ordering parts, please supply the following information:

- Dealer account number
- Dealer name and address
- Shipping address (if different than billing address)
- Return fax number
- Applicable model number
- Quantity, part number and description of each part
- Specify preferred method of shipment:
 - ✓ FedEx or UPS Ground
 - ✓ FedEx or UPS Second Day or Third Day
 - ✓ FedEx or UPS Next Day
 - ✓ Federal Express Priority One
 - ✓ DHL
 - ✓ Truck

Note: Unless otherwise indicated by customer, all orders are treated as "Standard Orders", and will ship within 24 hours. We will make every effort to ship "Air Shipments" the same day that the order is received, if prior to 2PM west coast time. "Stock Orders" must be so noted on fax or web forms.



Here's how to get help...

Please have the model and serial number on hand when calling.

STOW MAIN OFFICE

18910 Wilmington Ave. 800-421-1244
 Carson, CA 90746 FAX: 310-537-3927
 Email: stow@stowmfg.com
 Internet: www.stowmfg.com

SALES DEPARTMENT

310-661-4242 Fax: 310-604-9237
 877-289-7869 (877-BUY-STOW)

PARTS DEPARTMENT

800-427-1244 FAX: 800-672-7877
 310-537-3700 FAX: 310-637-3284

SERVICE DEPARTMENT

800-421-1244 FAX: 310-537-4259
 310-537-3700

TECHNICAL ASSISTANCE

800-478-1244 FAX: 310-631-5032

WARRANTY DEPARTMENT

800-421-1244, EXT. 279 FAX: 310-537-1173
 310-537-3700, EXT. 279

Place Your Parts Order Via Web or Fax For Even More Savings!

(Domestic USA Dealers Only)

Extra Discounts!

All parts orders which include complete part numbers and are received by our automated web parts order system, or by fax qualify for the following extra discounts:

Ordered via	Standard orders	Stock orders (\$750 list and above)
Fax	3%	10%
Web	5%	10%

Special freight allowances when you order 10 or more line items via Web or Fax! **

FedEx Ground Service **at no charge for freight**

No other allowances on freight shipped by any other carrier.

****Common nuts, bolts and washers (all items under \$1.00 list price) do not count towards the 10+ line items.**

NOTE: DISCOUNTS ARE SUBJECT TO CHANGE

STOW

A DIVISION OF MULTQUIP INC.
STOW CONSTRUCTION EQUIPMENT

A DIVISION OF MULTQUIP INC.

POST OFFICE BOX 6254 CARSON, CA 90749
 888-252-STOW [888-252-7869] 310-537-3700
 FAX: 310-537-1986 FAX: 800-556-1986
 E-MAIL: stow@multiquip.com INTERNET: www.stowmfg.com

Direct TOLL-FREE access to our Parts Department:

Toll-free nationwide — 800-427-1244

Toll-free FAX — 800-6-PARTS-7 (800/672-7877)

MS15H/MS15E MIXER — SPECIFICATIONS

Table 1. MS15H/MS15E Mixer Specifications

Capacity	4.0 cu. ft (113 liters)
Bag Capacity	1-1/2 to 2-1/2 bags
Weight MS15H	380 lbs. (172 kg.)
Weight MS15E	348 lbs. (158 kg.)
Length w/Tow Bar x W x H	67 x 30 x 41 in. (170 x 76 x 104 cm.)
Height W/Dump Handle	47 in. (119 cm.)
Discharge Height	7.5 in. (19 cm.)
Drive	V-Belt/Gear
Dump Action	Manual

Table 2. Specifications (Engine & Electric Motor)

	Model	HONDA GX160K1HX2	BALDOR 35S772T980G1
Engine/Electric Motor	Type	Air-cooled 4 stroke, Single Cylinder, OHV, Horizontal Shaft Gasoline Engine	1.0 HP, 115/230, Single Phase Electric Motor
	Bore X Stroke	2.70 in. X 1.80 in. (68 mm x 45 mm)	N/A
	Displacement	9.9 cu. in. (163 cc)	N/A
	Max Output	5.5 H.P./4000 R.P.M.	1.0 H.P./1725 RPM
	Fuel Tank Capacity	Approx. 0.95 U.S. Gallons (3.6 Liters)	N/A
	Fuel	Unleaded Gasoline	N/A
	Lube Oil Capacity	0.63 qt. (0.6 liter)	N/A
	Speed Control Method	Centrifugal Fly-weight Type	N/A
	Starting Method	Recoil Start	N/A
	Dimensions (L x W x H)		12.3 x 14.3 x 13.2 in. (312 x 362 x 335 mm)
Dry Net Weight		40.8 lbs. (15 Kg.)	Approx. 22 lbs. (10 Kg.)

MS15H/MS15E MIXER — DIMENSIONS

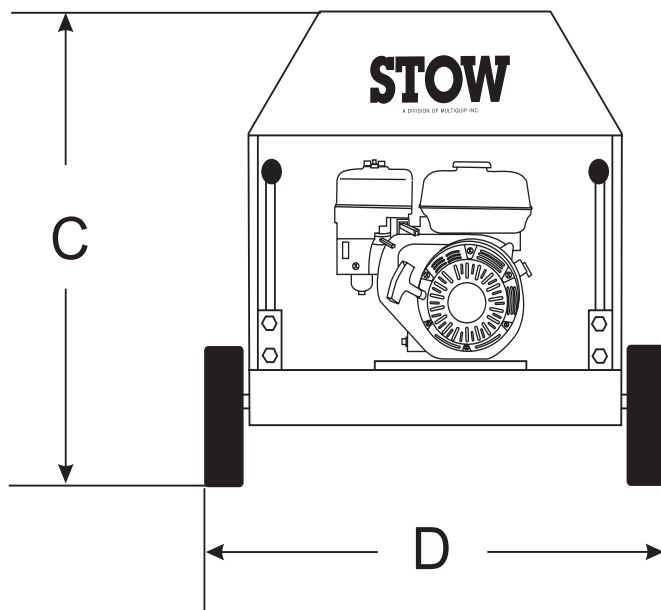
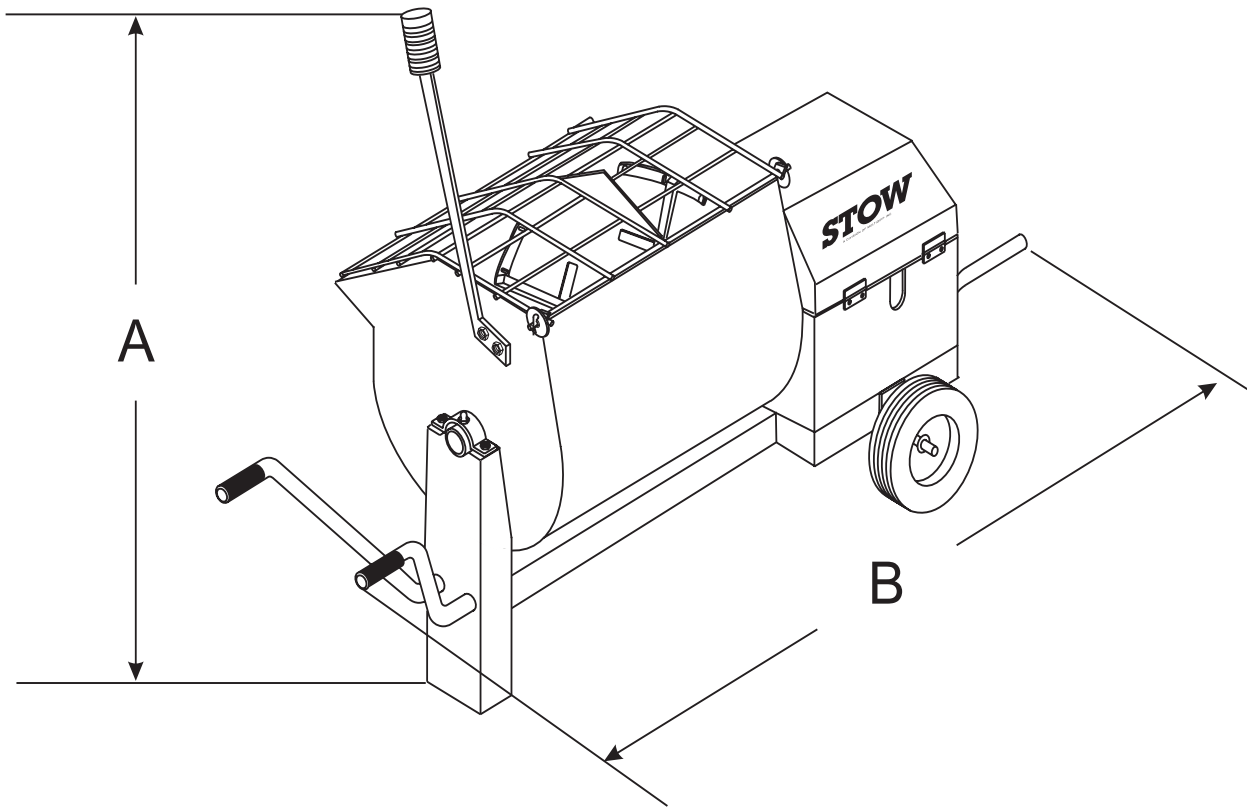

TABLE 3. DIMENSIONS	
Description	Dimensions in. (cm)
A	67 in. (170 cm)
B	50 in. (127 cm)
C	56 in. (142 cm)
C	56 in. (142 cm)

Figure 1. Dimensions

MS15H/MS15E MIXER — SAFETY MESSAGE ALERT SYMBOLS

FOR YOUR SAFETY AND THE SAFETY OF OTHERS!

Safety precautions should be followed at all times when operating this equipment. Failure to read and understand the Safety Messages and Operating Instructions could result in injury to yourself and others.

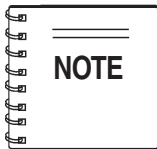

This Owner's Manual has been developed to provide complete instructions for the safe and efficient operation of the **STOW Model MS-15H/MS 15E mortar and plaster** mixer. Refer to the engine manufacturers instructions for data relative to its safe operation.

Before using this mixer, ensure that the operating individual has read and understands all instructions in this manual.

SAFETY MESSAGE ALERT SYMBOLS

The three (3) Safety Messages shown below will inform you about potential hazards that could injure you or others. The Safety Messages specifically address the level of exposure to the operator, and are preceded by one of three words: **DANGER**,

DANGER

You **WILL** be **KILLED** or **SERIOUSLY INJURED** if you **DO NOT** follow these directions.

WARNING

You **CAN** be **KILLED** or **SERIOUSLY INJURED** if you **DO NOT** follow these directions.

CAUTION

You **CAN** be **INJURED** if you **DO NOT** follow these directions.

HAZARD SYMBOLS

Potential hazards associated with the operation of a **MS-15H/MS15E Plaster/Mortar Mixer** will be referenced with Hazard Symbols which appear throughout this manual, and will be referenced in conjunction with Safety Message Alert Symbols.



WARNING

Lethal Exhaust Gas Hazards

Engine exhaust gases contain poisonous carbon monoxide. This gas is colorless and odorless, and can cause death if inhaled. **NEVER** operate this equipment in a confined area or enclosed structure that does not provide ample free flow air.



WARNING

Explosive Fuel Hazards

Gasoline is extremely flammable, and its vapors can cause an explosion if ignited. **DO NOT** start the engine near spilled fuel or combustible fluids.

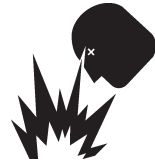

DO NOT fill the fuel tank while the engine is running or hot. **DO NOT** overfill tank, since spilled fuel could ignite if it comes into contact with hot engine parts or sparks from the ignition system. Store fuel in approved containers, in well-ventilated areas and away from sparks and flames.



WARNING

Burn Hazards

Engine components can generate extreme heat. To prevent burns, **DO NOT** touch these areas while the engine is running or immediately after operations. Never operate the engine with heat shields or heat guards removed.



WARNING

Respiratory Hazards

ALWAYS wear approved **respiratory** protection when required.



MS15H/MS15E MIXER — SAFETY MESSAGE ALERT SYMBOLS



CAUTION

Rotating Parts Hazards

NEVER operate equipment with covers, or guards removed. Keep fingers, hands, hair and clothing away from all moving parts to prevent injury.



CAUTION

Equipment Damage Hazards

Other important messages are provided throughout this manual to help prevent damage to your light tower, other property, or the surrounding environment.



CAUTION

Accidental Starting Hazards

ALWAYS place the power source, circuit breakers or **ON/OFF** switch in the **OFF** position, when the generator is not in use, unless connected to transfer switch.



CAUTION

Eye and Hearing Hazards

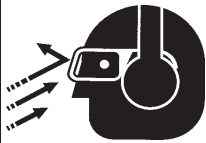

ALWAYS wear approved eye and hearing protection.

MS15H/MS15E MIXER — RULES FOR SAFE OPERATION

DANGER

Read this manual!

Failure to follow instructions in this manual may lead to serious injury or even death! This equipment is to be operated by trained and qualified personnel only! This equipment is for industrial use only.

The following safety guidelines should always be used when operating the STOW MS-40 mortar and plaster mixer:

GENERAL SAFETY

■ **DO NOT** operate or service this equipment before reading this entire manual.



■ This equipment should not be operated by persons under 18 years of age.

■ **NEVER** operate this equipment without proper protective clothing, shatterproof glasses, steel-toed boots and other protective devices required by the job.



■ **NEVER** operate this equipment when not feeling well due to fatigue, illness or taking medicine.



■ **NEVER** operate this equipment under the influence of **drugs** or **alcohol**.



■ **ALWAYS** wear proper respiratory (mask), hearing and eye protection equipment when operating the mixer.



■ **NEVER** place hands inside the drum while the blades are rotating.

■ Whenever necessary, replace nameplate, operation and safety decals when they become difficult read.

■ Manufacture does not assume responsibility for any accident due to equipment modifications.

■ **NEVER** use accessories or attachments, which are not recommended by Multiquip for this equipment. Damage to the equipment and/or injury to user may result.

■ **NEVER** touch the hot exhaust manifold, muffler or cylinder. Allow these parts to cool before servicing engine or mixer.



■ **High Temperatures** – Allow the engine to cool before adding fuel or performing service and maintenance functions. Contact with **hot!** components can cause serious burns.

■ The engine section of this mixer requires an adequate free flow of cooling air. **NEVER** operate the mixer in any enclosed or narrow area where free flow of the air is restricted. If the air flow is restricted it will cause serious damage to the mixer or engine and may cause injury to people. Remember the mixer's engine gives off **DEADLY** carbon monoxide gas.

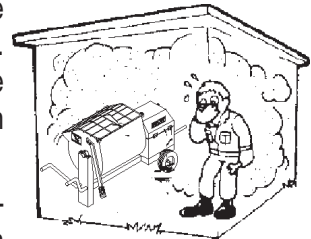

■ **ALWAYS** refuel in a well-ventilated area, away from sparks and open flames.

■ **ALWAYS** use extreme caution when working with **flammable** liquids. When refueling, **stop the engine** and allow it to cool. **DO NOT smoke** around or near the machine. Fire or explosion could result from fuel vapors, or if fuel is spilled on a hot engine.

■ **NEVER** operate the mixer in an explosive atmosphere or near combustible materials. An explosion or fire could result causing severe **bodily harm or even death**.

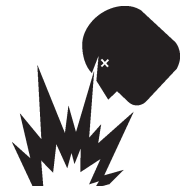

■ Topping-off to filler port is dangerous, as it tends to spill fuel.

■ Stop the engine when leaving the mixer unattended.

■ Block the unit when leaving or when using on a slope.

■ Maintain this equipment in a safe operating condition at all times.

WARNING

Starting the Mixer Engine

NEVER! start the engine or engage the paddle arms when the drum is in the discharge (down) position.

MS15H/MS15E MIXER — RULES FOR SAFE OPERATION

- **ALWAYS** stop the engine before servicing, adding fuel and oil.
- **NEVER** run engine without air filter. Severe engine may occur.
- **ALWAYS** service air cleaner frequently to prevent carburetor malfunction.
- **ALWAYS** check the machine for loosened threads or bolts before starting.
- **ALWAYS** be sure the operator is familiar with proper safety precautions and operations techniques before using mixer.
- **ALWAYS** store equipment properly when it is not being used. Equipment should be stored in a clean, dry location out of the reach of children.
- **DO NOT** operate this equipment unless all guards and safety devices are attached and in place.
- **CAUTION** must be exercised while servicing this equipment. Rotating and moving parts can cause injury if contacted.
- When towing, an adequate safety chain must be fastened to the frame. See Towing Guidelines section in this manual.
- Keep all **inexperienced** and **unauthorized** people away from the equipment at all times.
- Unauthorized equipment modifications will void all warranties.
- Check all fasteners periodically for tightness. Also check towing tongue bolt, lock nut and wheel lug nuts for wear.
- Stop the engine and disconnect the spark plug before allowing anybody's hands in the mixing drum.
- **NEVER** pour or spray water over the engine or electric motor.
- Depending on type of mixer, test the **ON/OFF** switch for either the gasoline engine or electric motor before operating. The purpose of these switches is to shut down the engine or motor of the mixer
- **ALWAYS** stand clear of the release drum lock. Move handle downward to empty the drum. Move handle upward to return to vertical position. Drum features automatic vertical locking mechanism. Inspect for proper functionality before starting engine or engaging blades. Any binding of material between the mixing blades and drum will cause the handle to quickly rotate if not in the "up and locked" position.

WARNING

Stand Clear of the Manual Dump Drum Handle

Always stand clear of the dump handle when the mixer is in operation.

- Refer to the **HONDA Engine Owner's Manual** for engine technical questions or information recommended by Multiquip for this equipment. Damage to the equipment and/or injury to user may result.

TRANSPORTING

- **ALWAYS** shutdown engine before transporting.
- Tighten fuel tank cap securely and close fuel cock to prevent fuel from spilling.
- Drain fuel when transporting mixer over long distances or bad roads.

WARNING

Stand Clear of the Mixer when in use

Always stand clear of the dump handle when the mixer is in operation. Any binding of material between the mixer blades and the drum will cause the drum handle to quickly move and could cause bodily harm.

MS15H/MS15E MIXER — RULES FOR SAFE OPERATION

MAINTENANCE

- **NEVER** lubricate components or attempt service on a running mixer.
- **ALWAYS** allow the mixer a proper amount of time to cool before servicing.
- Keep the mixer in proper running condition.
- Fix damage to the mixer immediately and always replace broken parts.
- Dispose of hazardous waste properly. Examples of potentially hazardous waste are used motor oil, fuel and fuel filters.
- **DO NOT** use food or plastic containers to dispose of hazardous waste.

EMERGENCIES

- **ALWAYS** know the location of the nearest **fire extinguisher** and **first aid kit**.



- In emergencies **always** know the location of the nearest phone or **keep a phone on the job site**. Also know the phone numbers of the nearest **ambulance**, **doctor** and **fire department**. This information will be invaluable in the case of an emergency.

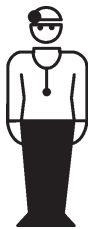

MS15H/MS15E MIXER — OPERATION AND SAFETY DECALS

Machine Safety Decals

This STOW mixer is equipped with a number of safety decals (Figure 2). These decals are provided for operator safety and maintenance information. The illustration below shows these decals as they appear on the mixer. Should any of these decals become unreadable, replacements can be obtained from your dealer.

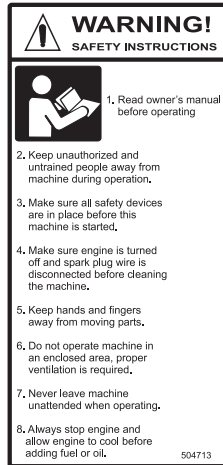

P/N 504713

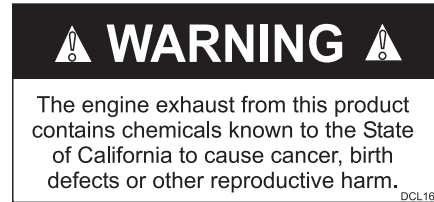

P/N DCL160

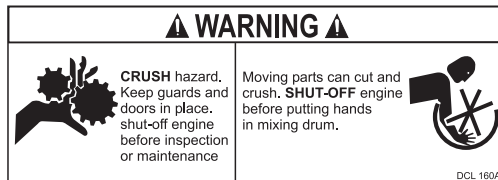

P/N DCL160A



P/N 25259-001



P/N 510165

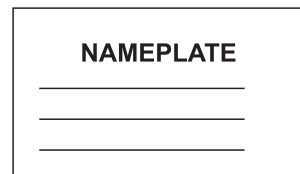

CONTACT MULTIQUIP
PARTS DEPT.



P/N 512527

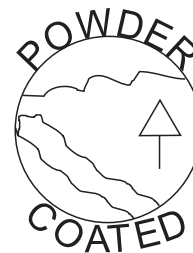

P/N 13118

Figure 2. Safety Decals

MS15H/MS15E MIXER — GENERAL INFORMATION

GENERAL

The MQ STOW Model MS15H5.5 (Honda GX160K1HX2 gasoline engines) and MS15E (electric motor) plaster and mortar mixers are shipped completely assembled and have been factory tested.

The drum batch capacity of these mixers is between 1.5 and 2.5 bags. With proper care, they will give continuous service year-after-year.

These mixers can be powered by either gasoline or electric motors. The shaft of the engine or electric motor is connected to a drive belt pulley which is attached to a main gear. As the main gear rotates it causes the paddle shaft to rotate.

BEFORE STARTING

Before starting the engine, read the engine owners manual and thoroughly understand the safety information.

Check the items listed below:

OIL LEVELS

Be sure to check the oil levels in the engine and engine reduction unit before starting the unit (gasoline model only).

HARDWARE

Check all hardware on the mixer before starting. Periodically inspect all hardware. Loose hardware can contribute to early component failure and poor performance. Use the torque chart below as a general guideline and keep all hardware tight:

<u>HARDWARE DIA</u>	<u>TORQUE (LB./FT.)</u>
5/16" - 18	24
3/8" - 24	37
1/2" - 13	39
1/2" - 13 (Grade 8)	90

GASOLINE ENGINE CARE

For care and operation of the gasoline engine, refer to the engine manufacturer's operating instructions furnished with the engine. We recommend draining and refilling the engine crankcase at least every thirty hours of operation. Check the engine oil level daily.

GASOLINE MIXER OFF/ON SWITCH

This feature is on gasoline engine mixers only. Located on the side of the engine cover. The purpose of this switch is to start and stop the mixer in normal operation.

ELECTRIC MOTOR MIXER OFF/ON SWITCH

This feature is on electric motor mixers only. This switch is located on top of the motor. Lift the engine cover to gain access to this switch. The purpose of this switch is to start and stop the mixer in normal operation. **NEVER** use the electric motor in an explosive environment.

ENGINE THROTTLE AND CHOKE CONTROLS

Please refer to the engine owners manual for specific instructions.

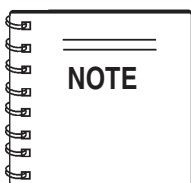

In accordance with our established policy of constant improvement, we reserve the right to amend these specifications at any time without notice.

MS15H/MS15E MIXER — MIXER COMPONENTS

Figure 3. Mixer Components

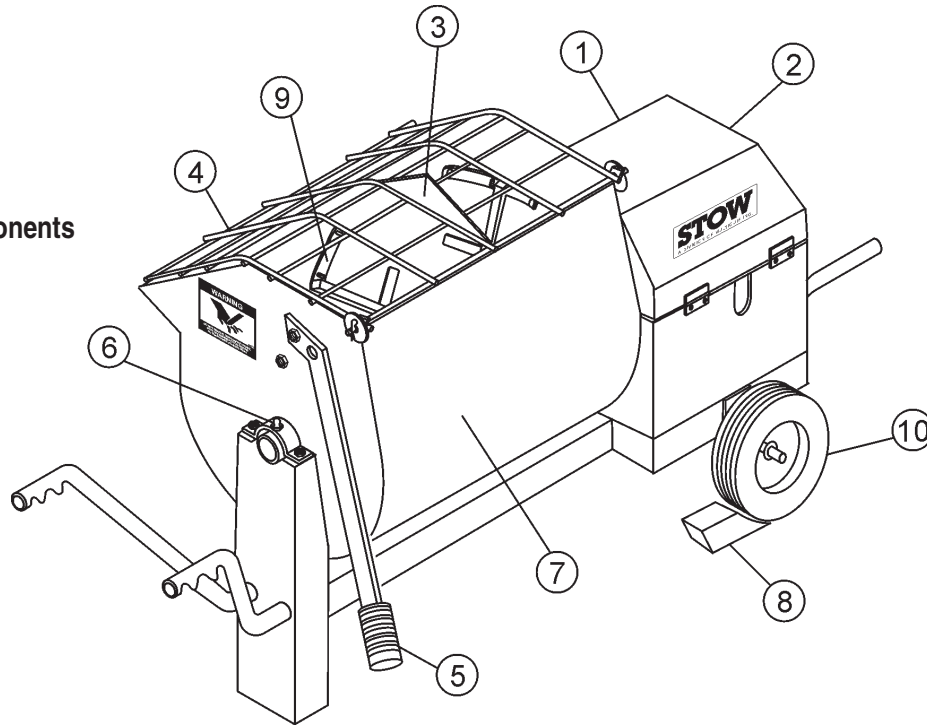

Figure 3 illustrates the basic components and controls of the MS15H/MS15E mixer.

1. **Engine Cover** — Lift this cover to gain access to the engine compartment.
2. **ON/OFF Switch (electric)** — This switch is provided on mixers with electric motors. To gain access to this switch, lift the engine cover. When activated it will shut down the electric motor.
3. **Bag Cutter** — This feature allows compound mixing bags to be opened easily, therefore allowing the contents of the bag to fall directly into the mixing drum.
4. **Safety Grill** — Provided for operator safety. This safety grill is designed to keep hands and solid objects out of the mixing drum when in use. This grill should be closed at all times when mixer is in use. **DO NOT** remove the grill or grill opening bar. Keep the grill clean by washing it down daily.
5. **Dump Handle** — Pull this handle downward to dump the contents of the drum. Push the handle upward to return the drum to its vertical position.
6. **Pivot Point/Zerk Fitting** — There is, on each end of the mixing drum a zerk grease fitting. These fittings lubricate the dumping mechanism. Lubricate both fittings at least twice a week.
7. **Steel Mixing Drum** — Mixing materials such as mortar, plaster are to be placed into this drum for mixing. Always clean the drum after each use.
8. **Chock Blocks** — Place these blocks (not included as part of the mixer package) under each mixer wheel to prevent rolling.
9. **Mixing Paddles** — Used in the mixing of material. This unit uses four different types of paddles to provide a fast uniform mix.
10. **Tires** — Replace tires with the recommended type tire of 12 x 3.

MS15H/MS15E MIXER — BASIC ENGINE COMPONENTS

Honda GX Series Engine Shown

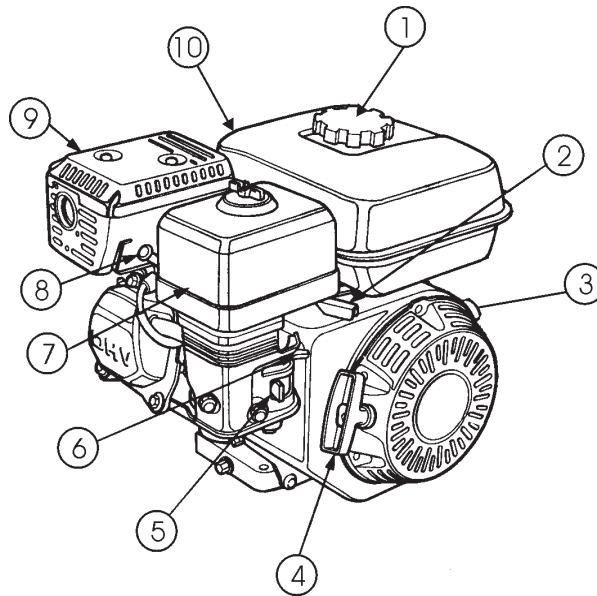

Figure 4. Engine Controls and Components

INITIAL SERVICING

The engine (Figure 4) must be checked for proper lubrication and filled with fuel prior to operation. Refer to the manufacturer's Engine manual for instructions & details of operation and servicing.

1. **Fuel Filler Cap** – Remove this cap to add unleaded gasoline to the fuel tank. Make sure cap is tightened securely. **DO NOT** over fill.



WARNING

Adding fuel to the tank should be accomplished only when the engine is stopped and has had an opportunity to cool down. In the event of a fuel spill,

DO NOT attempt to start the engine until the fuel residue has been completely wiped up, and the area surrounding the engine is dry.

2. **Throttle Lever** – Used to adjust engine RPM speed (lever advanced forward **SLOW**, lever back toward operator **FAST**).
3. **Engine ON/OFF Switch** – ON position permits engine starting, OFF position stops engine operations.
4. **Recoil Starter (pull rope)** – Manual-starting method. Pull the starter grip until resistance is felt, then pull briskly and smoothly.

5. **Fuel Valve Lever** – **OPEN** to let fuel flow, **CLOSE** to stop the flow of fuel.
6. **Choke Lever** – Used in the starting of a cold engine, or in cold weather conditions. The choke enriches the fuel mixture.
7. **Air Cleaner** – Prevents dirt and other debris from entering the fuel system. Remove wing-nut on top of air filter canister to gain access to filter element.

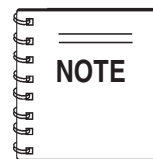

NOTE

Operating the engine without an air filter, with a damaged air filter, or a filter in need of replacement will allow dirt to enter the engine, causing rapid engine wear.

8. **Spark Plug** – Provides spark to the ignition system. Set spark plug gap to 0.6 - 0.7 mm (0.028 - 0.031 inch). Clean spark plug once a week.
9. **Muffler** – Used to reduce noise and emissions.



WARNING

Engine components can generate extreme heat. To prevent burns, **DO NOT** touch these areas while the engine is running or immediately after operating. **NEVER** operate the engine with the muffler removed.

10. **Fuel Tank** – Holds unleaded gasoline. For additional information refer to engine owner's manual.

MS15H/MS15E MIXER — ELECTRIC MOTOR

Electric Motor

For maintenance care and operation of the electric motor, refer to your electric motor instruction booklet furnished with the motor.

Protect the electric motor from dust as much as possible and keep ventilating openings clean.

	CAUTION	Electric Motor Safety
<p>DO NOT spray water at any time on the electric motor.</p> <p>DO NOT operate electric motor in a explosive environment.</p>		

The electric motor used in this mixer is a single-phase 1.0 HP motor. The input voltage requirement for this motor is either 115 or 230 VAC only.

Electric Motor Connection

A 12 inch electrical cable (Figure 3) with a pigtail at one end is provided with the electrical motor for hookup to a power source. Table 2. shows the required NEMA connector for the desired motor horsepower rating. In addition, Table 3 also shows the matching NEMA approved connector for the required extension cord.

ALWAYS, make certain that the power source required for the electric motor is **correct** and always use the correct NEMA configuration plug. **Failure** to supply the correct voltage to the motor can severely damage the motor.

The motor supplied is wired for 115 VAC grounded operation. Make certain that the correct size grounded (3-wires) extension cord is used. See Table 4.

Motors can burn out when the line voltage falls 10% below the voltage rating of the motor. Failure to use proper voltage will cause the motor to overheat and actuate the overload switch.

If overload protection should actuate because of improper voltage or any other malfunction, turn the main switch on the motor to the "OFF" position and correct the problem, press the reset switch button, and turn the main switch to the "ON" position.

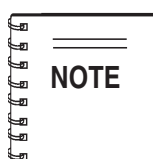

It is strongly recommended that all electrical wiring be done by a **licensed electrician**.

Electric Motor Voltage Switch

1. **ALWAYS** make certain the motor switch is "OFF" and the power cord has been disconnected from the power source.
2. Remove the voltage lock-out bolt (Figure 2). Change the position of the **voltage change toggle switch** from 115 VAC to 230 VAC. The mixer is factory wired for 115 VAC operation.
3. Replace the voltage lock-out bolt.
4. **Important!**, when changing the input voltage to the motor from 115 to 230 VAC the **plug** on the motor power cord must also be changed. See Table 3.

Table 3. Electric Motor Wiring Information

Motor Horsepower Rating	115-230 VAC - Single Phase	
	NEMA Plug Connector	Mating NEMA Receptacle Connector
1.0 HP (115 VAC)	L5-20P P/N EM940537	L5-20R P/N EM940538
1.0 HP (230 VAC)	L6-20P P/N 940539	L6-20R P/N 940540

Table 4. Recommended Extension Cord Sizes

Model	Motor	Voltage	50 ft. (15.24 m)	75 ft. (22.86 m)	100 ft. (30.48 m)	200 ft. (60.96 m)
MS15E (Electric)	1.0 HP	115	No. 12	No. 10	No. 8	No. 6
		230	No. 14	No. 12	No. 12	No. 8

	CAUTION	Electric Motor Connections
<p>ALWAYS make certain that the power source required for the electric motor is correct and always use the correct NEMA configuration plug. Failure to supply the correct voltage to the motor can severely damage the motor.</p>		

MS15H/MS15E MIXER — ELECTRIC MOTOR

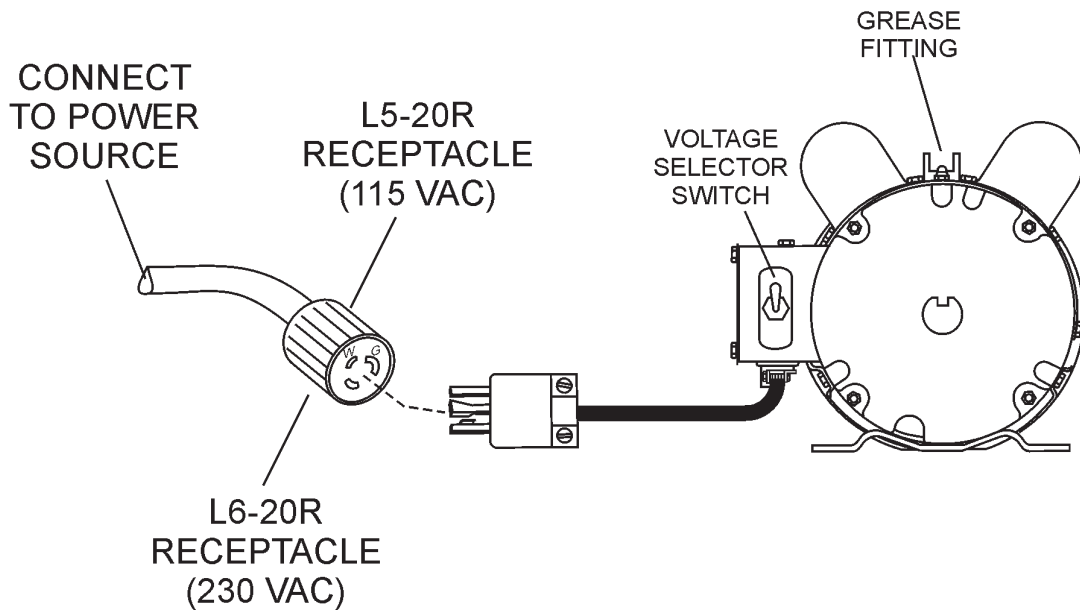
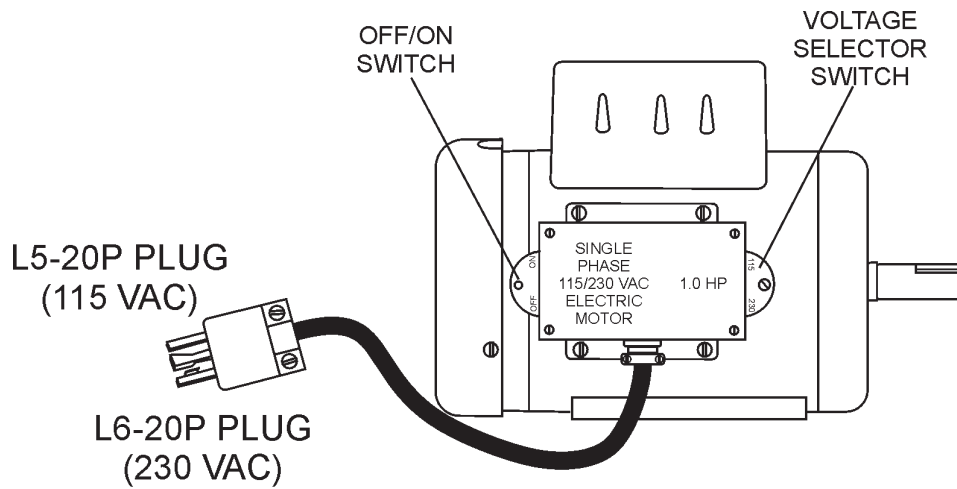

Figure 5. Single Phase Electric Motor with 18 inch Pigtail Cable

MS15H/MS15E MIXER — PADDLE BLADE ADJUSTMENT

Adjust paddles as shown in Figure 6.

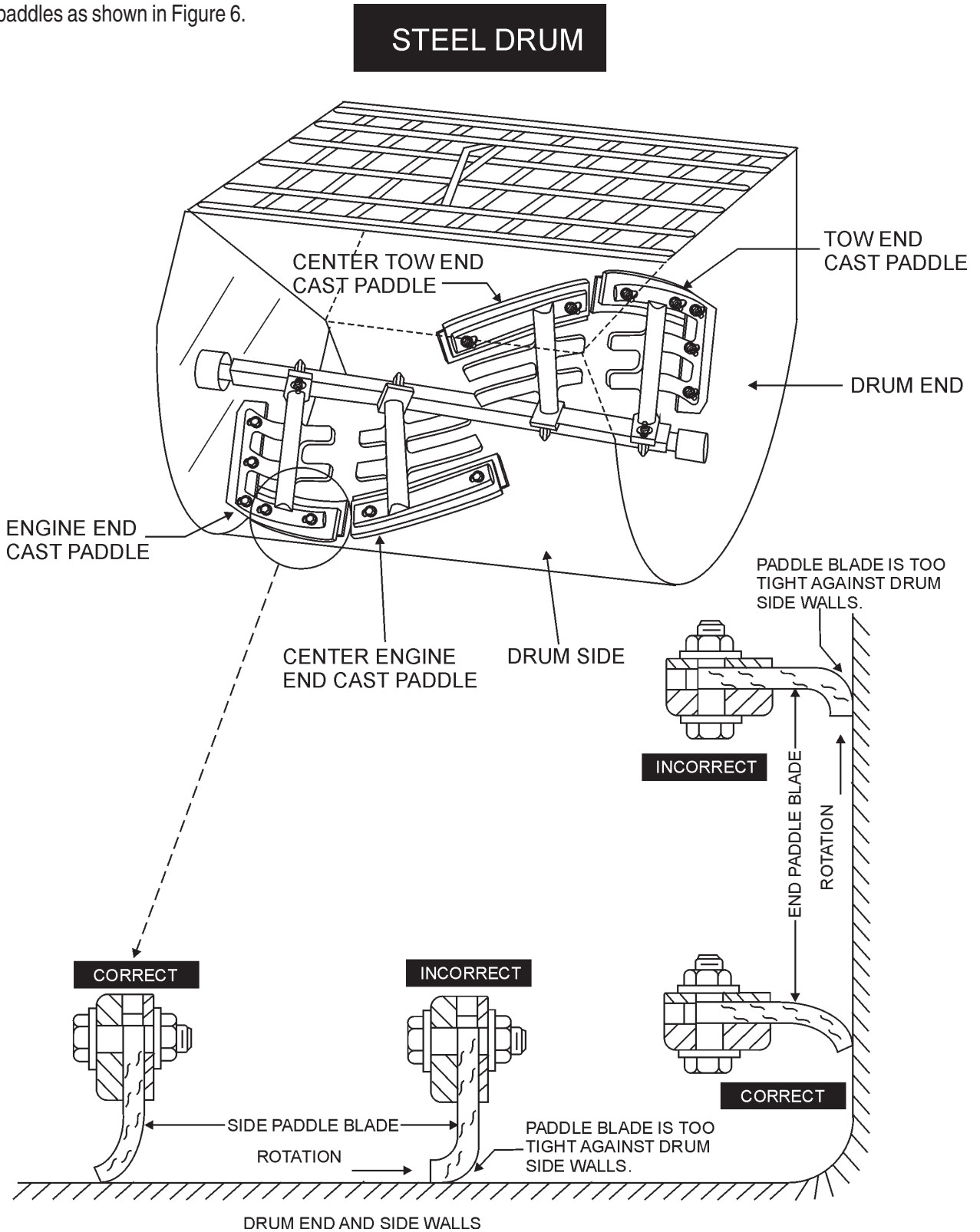

Figure 6. Paddle Blade Adjustment, Steel Drum

MS15H/MS15E MIXER — INSPECTION

Before Starting

1. Read **all safety instructions** at the beginning of manual.
2. Clean the **mixer**, removing dirt and dust, particularly the engine cooling air inlet, carburetor and air cleaner.
3. Check the air filter for dirt and dust. If air filter is dirty, replace air filter with a new one as required.
4. Check carburetor for external dirt and dust. Clean with dry compressed air.
5. Check fastening nuts and bolts for tightness.

2. Remove the filler dipstick from the engine oil filler hole (Figure 7) and wipe it clean.

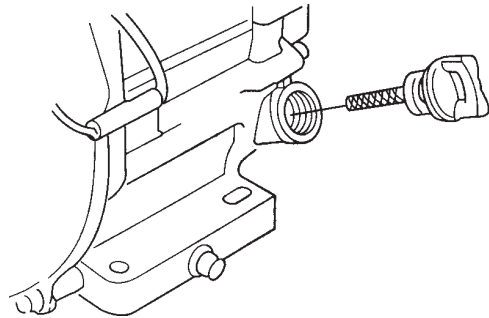

Figure 7. Engine Oil Dipstick (Removal)

3. Insert and remove the dipstick without screwing it into the filler neck. Check the oil level shown on the dipstick.
4. If the oil level is low (Figure 8), fill to the edge of the oil filler hole with the recommended oil type (Table 7). Maximum oil capacity is 2.33 qts. (1.09 liters)

CAUTION

Eyesight and Hearing Protection

ALWAYS wear approved eye and hearing protection before operating the mixer.

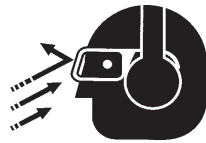

CAUTION

Inspection & Maintenance Safety

NEVER place hands or feet inside the engine guard cover while the engine is running. **ALWAYS** shut the engine down before performing any kind of maintenance service on the mixer.

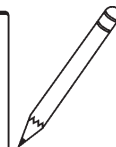
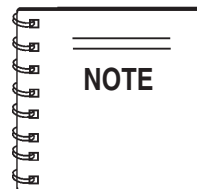

Reference manufacturer engine manual for specific servicing instructions.

WARNING

Explosive Fuel Hazard

Failure to understand the operation of the WM-120 series mixers could result in **severe damage** to the mixer or **personal injury**.

See Figure 5 for the location of any control referenced in this manual.

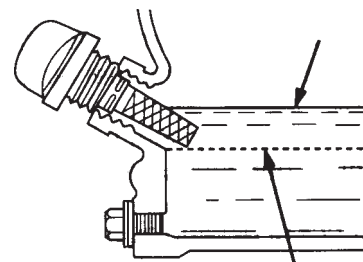

Figure 8. Engine Oil Dipstick (Oil Level)

CAUTION

Respiratory Hazard





NEVER operate the mixer in a confined area or enclosed area structure that does not provide ample **free flow of air**.

Table 5. Oil Type

Season	Temperature	Oil Type
Summer	25°C or Higher	SAE 10W-30
Spring/Fall	25°C~10°C	SAE 10W-30/20
Winter	0°C or Lower	SAE 10W-10

Fuel Check

 DANGER	Explosive Fuel Hazard
<p>If your mixer has a gasoline engine, determine if the engine fuel is low. If fuel is low, remove the fuel filler cap and fill with unleaded gasoline. Motor fuels are highly flammable and can be dangerous if mishandled. DO NOT smoke while refueling. DO NOT attempt to refuel the mixer if the engine is hot! or running.</p>	
	

1. Remove the gasoline cap located on top of fuel tank.
2. Visually inspect to see if fuel level is low. If fuel is low, replenish with unleaded fuel.
3. When refueling, be sure to use a strainer for filtration. **DO NOT** top-off fuel. Wipe up any spilled fuel.

 CAUTION	Start/Stop Switch
<p>NEVER! <i>disable or disconnect the start/stop switch. It is provided for operator safety. Injury may result if it is disable, disconnected or improperly maintained.</i></p>	

V-belt Check

A worn or damaged V-belt can adversely affect the performance of the mixer. If a V-belt is defective or worn simply replace the V-belt as outlined in the maintenance section of this manual.

Blade Check

Check for worn or paddle blades. Make sure that all blades are adjusted properly. See blade adjustment procedure in this manual. Replace all defective or damaged blades immediately.

Controls

Start/Stop Switches

This mixer has been equipped with a start/stop switch for both the gasoline and electric motor mixers. These switches should be tested every time the engine or electric motor is started.

Grease Fittings (Dumping Mechanism)

Check the zerk grease fittings at each end of the mixing drum. These grease fittings lubricate the dumping mechanism. If the dumping handle is stiff or hard to move lubricate these fittings.

MS15H/MS15E MIXER — START-UP PROCEDURES

This section is intended to assist the operator with the initial start-up of the MS-15H (gasoline) or MS15E (electric) mixer. It is extremely important that this section be read carefully before attempting to use the mixer in the field.



DO NOT use your mixer until this section is thoroughly understood.

CAUTION

Failure to understand the operation of the MS15H/MS15E mixers could result in severe damage to the mixer or personal injury.

See Figure 3 for the location of any control referenced in this manual.

Starting (gasoline only)

The following steps outline the procedure for starting the engine. Depending on the type of engine employed in the mixer the steps may vary slightly. If your mixer has an electric motor disregard this section.

1. Move the fuel shut-off lever (Figure 9) to the **ON** position.

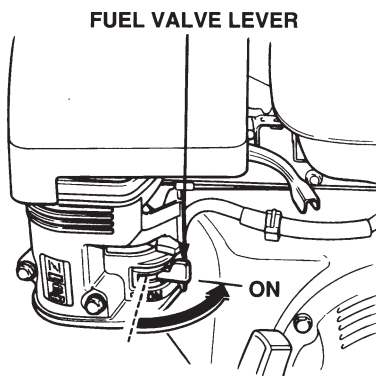

Figure 9. Fuel Shut-OFF Lever

2. To start a cold engine, move the choke lever (Figure 10) to the **CLOSED** position.

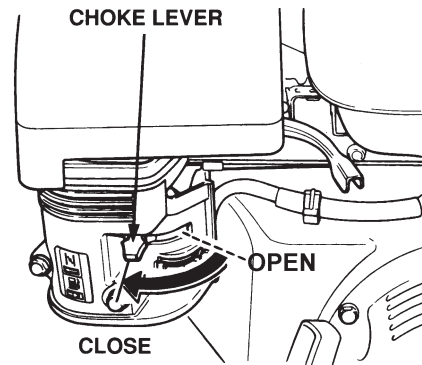

Figure 10. Choke Lever

3. Move the throttle lever (Figure 11) away from the slow position, about 1/3 of the way toward the fast position.

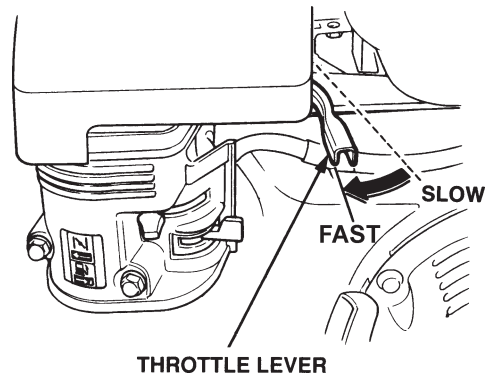

Figure 11. Throttle Lever

MS15H/MS15E MIXER — START-UP PROCEDURES

- Turn the engine switch (Figure 12) to the ON position.

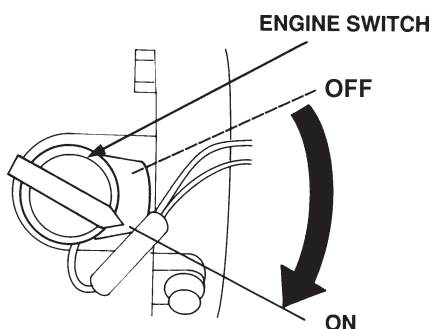

Figure 12. Engine ON/OFF Switch (ON)

- Pull the **starter grip** (Figure 13) lightly until you feel resistance, then pull briskly. Return the starter grip gently.

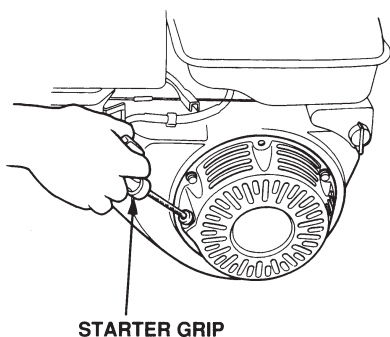

Figure 13. Starter Grip

Starting (electric only)

- Using an adequate size extension cord (see Table 4), connect one end of the extension cord to the plug on the electric motor, connect the other end to the power source. Make sure the motor is configured for the proper operating voltage.
- Set the electric motor's **ON/OFF** switch (Figure 5) to the **ON** position.

Mixing Dumping

- The paddle shaft inside the drum should be rotating at this time.
- Lift the mixing bag compound onto the steel grate over the bag cutter and let the contents fall into the drum.
- Add water, and mix compound to desired consistency.

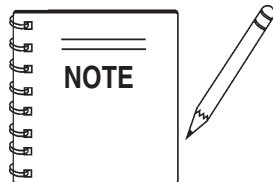

Be sure to stand clear of the **dump handle** when the mixer is operational. Any binding of material between the mixer blades and the drum will cause the drum handle to move to the discharge position, thus causing bodily harm.

Stopping the Mixer (Electric Motor)

- Place the engine **ON/OFF** switch (Figure 14) in the **OFF** position.

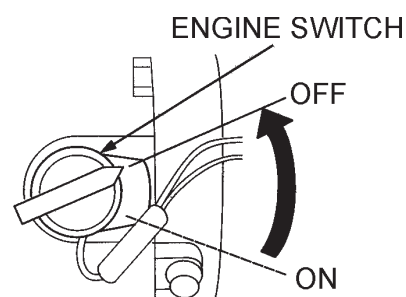

Figure 14. Engine ON/OFF Switch (OFF)

- Place the fuel shut-off valve in the OFF position.
- Disconnect the spark plug wire.
- Clean drum of all debris and foreign matter.
- Store mixer in a clean dry location.



DANGER

DO NOT Disconnect the Start/Stop Switch

NEVER disable or disconnect the start/stop switch. It is provided for operator safety. **Serious Injury** may result if it is disabled, disconnected or improperly maintained.

Stopping the Mixer (Electric Motor)

- Place the electric motor's **ON/OFF** switch in the **OFF** position.
- Disconnect the electric motor's extension cord from its power source.
- Clean drum of all debris and foreign matter.
- Store mixer in a clean dry location.

MS15H/MS15E MIXER — MAINTENANCE (ENGINE)

Use Table 8 as a general maintenance guideline when servicing your engine. For more detail engine maintenance information, refer to the engine owner's manual supplied with your engine.

Table 8. Engine Maintenance Schedule

DESCRIPTION (3)	OPERATION	BEFORE	FIRST MONTH OR 10 HRS.	EVERY 3 MONTHS OR 25 HRS.	EVERY 6 MONTHS OR 50 HRS.	EVERY YEAR OR 100 HRS.	EVERY 2 YEARS OR 200 HRS.
Engine Oil	CHECK	X					
	CHANGE		X				
Air Cleaner	CHECK	X					
	CHANGE			X (1)			
All Nuts & Bolts	Re-tighten If Necessary	X					
Spark Plug	CHECK-CLEAN				X		
	REPLACE						X
Cooling Fins	CHECK				X		
Spark Arrester	CLEAN					X	
Fuel Tank	CLEAN					X	
Fuel Filter	CHECK					X	
Idle Speed	CHECK-ADJUST					X (2)	
Valve Clearance	CHECK-ADJUST						X (2)
Fuel lines	CHECK	Every 2 years (replace if necessary) (2)					

(1) Service more frequently when used in **DUSTY** areas.

(2) These items should be serviced by your service dealer, unless you have the proper tools and are mechanically proficient. Refer to the HONDA Shop Manual for service procedures.

(3) For commercial use, log hours of operation to determine proper maintenance intervals.

MS15H/MS15E MIXER — MAINTENANCE (MIXER)

Drum Head Seals

There is 1 set of drum head seals (Figure 15) that will require lubrication.



CAUTION

IMPORTANT- DRUM HEAD SEAL CARE

Grease seals every **40 hours of operation** using any grade #1 lithium base grease. Apply grease until visible of mixing tub (over grease). This will purge seal system of contamination.

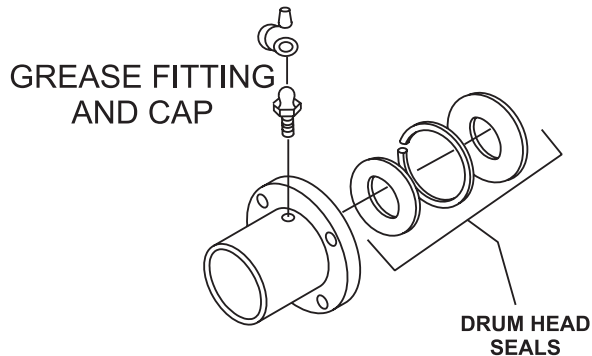

Figure 15. Grease Fittings (Drum Head Seals)

Drum Bearing Bracket Lubrication

There is 1 set of drum bearing brackets (Figure 16) that will require lubrication. These brackets are intended to make the drum rotate freely. Lubricate the grease fitting for each drum bearing bracket **every month or when the drum becomes difficult to position** using multi-purpose grade grease.

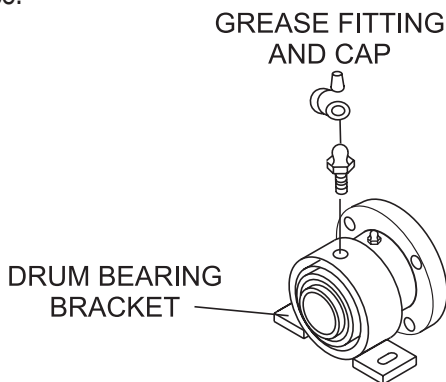

Figure 16. Grease Fittings (Dumping Mechanism)



CAUTION

Lubricating the Zerk Grease Fittings

Failure to lubricate the zerk grease fittings periodically will cause the dumping mechanism to stiffen, making the mixing drum hard to dump.



CAUTION

Lubricating the Grease Fittings

Failure to lubricate the drum bearing grease fittings periodically will cause the dumping mechanism to stiffen, making the mixing drum hard to dump.

Countershaft Bearing Lubrication

There is 1 set of countershaft bearings (Figure 17) that will require lubrication. Lubricate the grease fitting for each countershaft bearing **every 40 hours of operation** using any grade lithium base grease.

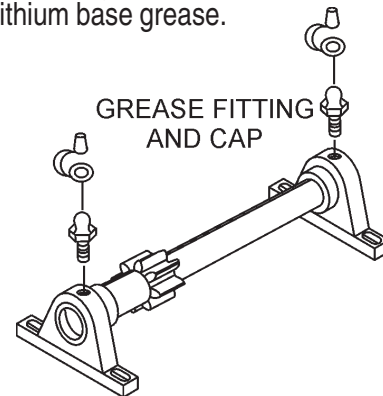

Figure 17. Grease Fittings (Countershaft)

Grease Fittings (Zerk) Maintenance (Electric Motor)

1. There are two grease (Figure 18) fittings at each end of the electric motor that will require lubrication. Lubricate these fittings about **every 16 months**.
2. Use Poleyrex EM (Exxon Mobil) or equivalent lubricant. Clean grease fitting, apply grease gun to fitting (1/2 shot). Remember too much grease or injecting grease too quickly can cause premature bearing failure. Slowly apply the recommended amount of grease, taking a minute or so to apply.

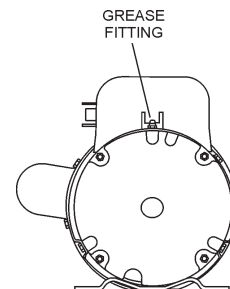

Figure 18. Grease Fittings Electric Motor

MS15H/MS15E MIXER — MAINTENANCE (MIXER)

MAIN GEAR AND DRIVE PINION ALIGNMENT

1. **Disconnect the spark plug wire** (gasoline engines). If mixer is equipped with an electric motor **remove power cord from AC power receptacle**. In addition make sure the clutch engagement lever is **dis-engaged** to relieve V-belt tension.
2. The countershaft and drive pinion are mounted on a slotted base. To align drive pinion with main gear, loosen the pillow block mounting bolts and move them until the necessary alignment has been made. Remember gears must be paralleled aligned not skewed.
3. Using your hand, slightly move (rock) the drive pulley back and forth to determine the amount of backlash. Insert feeler gauge between gears to determine backlash distance. Backlash should range between 0.007- 0.012 inches (Figure 19).

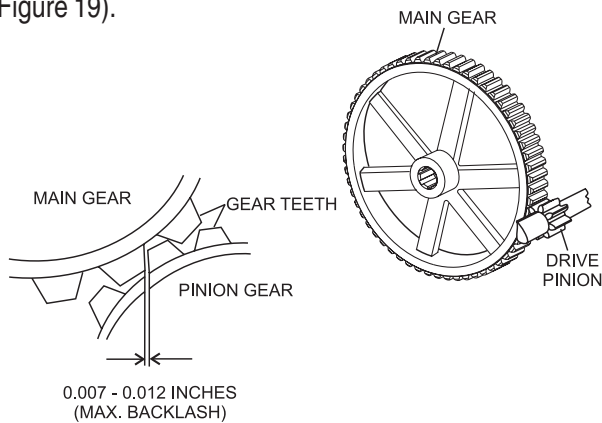

Figure 19. Drive Pinion and Main Gear (Backlash)

INSPECT TOOTH CONTACT BETWEEN MAIN GEAR AND DRIVE PINION

1. Coat 3 or 4 teeth at 3 different positions on the main gear with yellow paint.
2. Rotate the drive pulley in both directions.
3. Inspect the tooth pattern.
4. If gear teeth are not contacting properly (Figure 20), adjust pillow block to correct the problem.

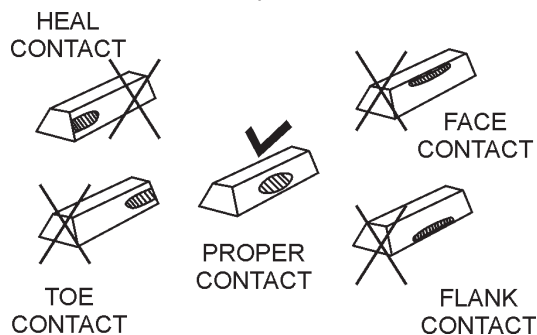
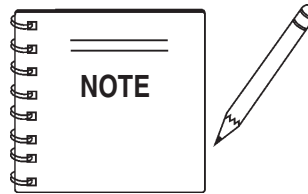

Figure 20. Gear Teeth Alignment

GEAR LUBRICATION

The surface of the pinion and main gear (Figure 21) should be very lightly greased.



Grease main and pinion gears every **250 hours of operation**. **IMPORTANT! avoid over-greasing. Excess grease will accumulate contaminates and cause premature wear.**

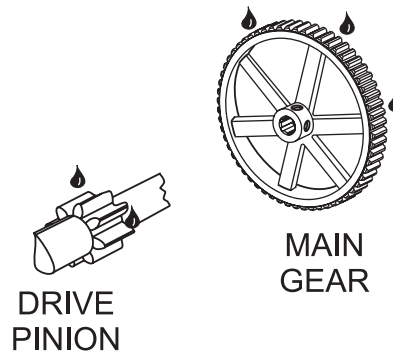

Figure 21. Pinion and Bull Gear Lubrication

CLEANING



CAUTION

Cleaning the Mixer

Always disconnect the spark plug wire before cleaning the inside of the drum.

NEVER pour or spray water (Figure 22) over the gasoline engine or electric motor.

For consistent performance, long life and high quality mixing, thoroughly clean the mixer inside and out at the end of each day's operation. To prevent lumps of dried mortar from forming and contamination of future batches, do not allow a buildup of materials to form on the blades or anywhere inside the drum.

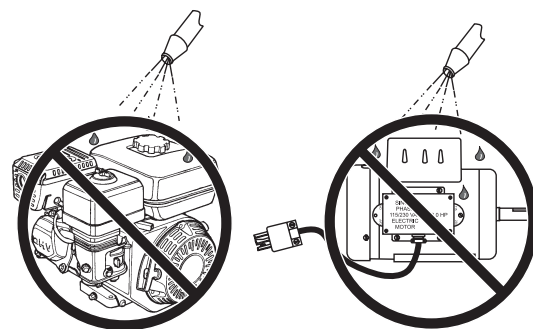

Figure 22. No Spraying of Water

MS15H/MS15E MIXER — TROUBLESHOOTING (ENGINE)

Practically all breakdowns can be prevented by proper handling and maintenance inspections, but in the event of a breakdown, please take a remedial action following the diagnosis based on the **Engine**, **Mixer** and **Electric Motor** Troubleshooting (Tables 6, 7 and 8) information shown below and on the proceeding pages.

If the problem cannot be remedied, please leave the unit just as it is and consult or company's service department.

TABLE 6. ENGINE TROUBLESHOOTING

SYMPTOM	POSSIBLE PROBLEM	SOLUTION
Poor starting	Inspect carburetor to see if fuel is reaching it?	Check fuel line
	No Fuel?	Add Fuel
	Water in fuel tank?	Flush or replace fuel tank.
	Fuel filter clogged?	Replace fuel filter
	Stuck carburetor?	Check float mechanism.
	Spark plug is red?	Spark plug is fouled. Check transistor ignition unit.
	Spark plug is blue-white?	Insufficient compression, injected air leaking. Carburetor jets are clogged (overflow).
	No spark present at tip of spark plug?	Transistor ignition unit broken, high voltage cord cracked or broken. Start/Stop switch broken. Replace spark plug if fouled.
	No oil?	Add oil as required.
	Oil pressure alarm lamp blinks upon starting?	Check Automatic shutdown circuit "oil sensor".
Insufficient power output "no compression"	Engine will not turn over?	Replace cylinder and piston and if necessary axle joint.
	Cylinder head connecting bolts loose?	Tighten cylinder head connecting bolts.
	Cylinder head gasket damaged?	Replace cylinder head gasket.
	Malfunition of valve seat?	Re-seat valves.
	Spark plug is loose?	Replace spark plug.
	Worn piston rings?	Replace piston rings.
Insufficient power output "compression"	Malfunition in air-cleaner system, air filter clogged?	Clean or replace air filter.
	Air leaking in from interface between carburetor and cylinder head?	Tighten bolts between carburetor and cylinder head. Replace cylinder head gasket.
	Malfunition in fuel system?	Clean or replace fuel filter. Clean or replace carburetor. Check carburetor float.

MS15H/MS15E MIXER — TROUBLESHOOTING (ENGINE)

TABLE 6. ENGINE TROUBLESHOOTING (CONTINUED)

SYMPTOM	POSSIBLE PROBLEM	SOLUTION
Insufficient power output "compression" and overheats	Malfunction in cooling fan?	Check or replace cooling fan.
	Air in-take filter clogged?	Clean or replace air in-take filter.
Burns to much fuel	Over accumulation of exhaust products?	Clean and check valves. Check muffler, replace if necessary.
	Wrong spark plug?	Replace spark plug with manufactures suggested type spark plug.
Exhaust color is continiously "WHITE"	Lubricating oil is wrong viscosity?	Replace lubricating oil with correct viscosity.
	Worn rings?	Replace rings
Exhaust color is continiously "BLACK"	Air cleanner clogged?	Clean or replace air cleaner.
	Choke valve has not been set to the correct position?	Adjust choke valve to the correct position.
	Carburetor defective, seal on carburetor broken?	Replace carburetor or seal.
	Poor carburetor adjustment "engine runs too rich?"	Adjust carburetor.

MS15H/MS15E MIXER — TROUBLESHOOTING (MIXER/MOTOR)

TABLE 7. MIXER TROUBLESHOOTING

SYMPTOM	POSSIBLE PROBLEM	SOLUTION
Blades will not rotate.	Worn or defective V-belt?	Replace V-belt.
	No power?	Check electric or gasoline engine.
Material leaking from drum ends.	Worn or defective paddle shaft seals?	Replace seals.
Drum difficult to discharge (tilt)	Defective or worn drum support brackets?	Apply grease to bracket or replace.
	Blades adjusted too tight?	Adjust blades until they almost touch side walls of drum.

TABLE 8. ELECTRIC MOTOR TROUBLESHOOTING

SYMPTOM	POSSIBLE PROBLEM	SOLUTION
Blades will not rotate.	No voltage to motor?	Check power source.
	Defective extension cord?	Replace extension cord.
	Defective motor ON/OFF switch?	Replace switch.
	Defective motor windings?	Repair windings or replace windings.
	Worn or defective V-belt?	Replace V-belt.

MS15H/MS15E MIXER — WIRING DIAGRAM (ELECTRIC MOTOR)

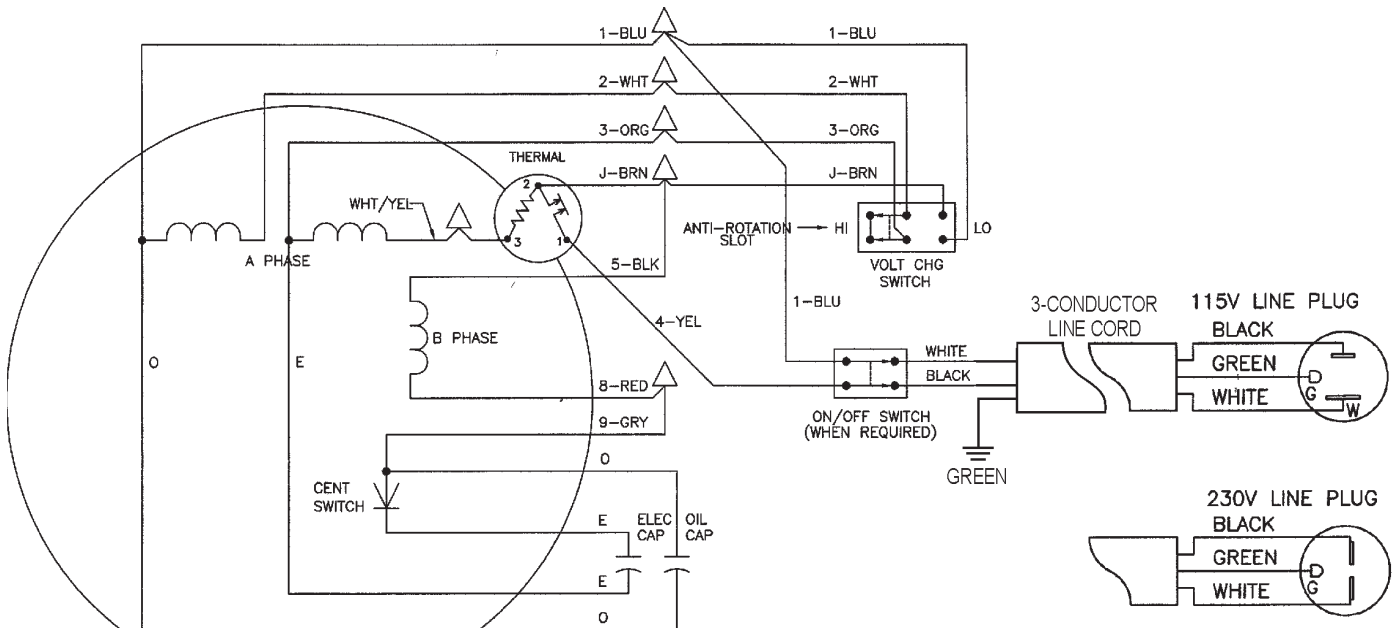

NOTES

- 1 CONNECTIONS ARE SHOWN FOR CCW ROTATION FACING END OPPOSITE SHAFT EXTENSION (STD). FOR CW ROTATION, INTERCHANGE 5 AND 8 LEADS
- 2 MULTIPLE CAPACITORS ARE CONNECTED IN PARALLEL UNLESS OTHERWISE SPECIFIED
- 3 USE 2PDT VOLTAGE CHANGE SWITCH. CONTACTS ARE SHOWN IN HIGH VOLT POSITION. VIEW IS FROM TERMINAL SIDE
- 4 LEAD COLORS ARE OPTIONAL. LEADS MUST ALWAYS BE NUMBERED AS SHOWN

INTERNAL CONNECTION FOR TWO TERMINAL THERMAL

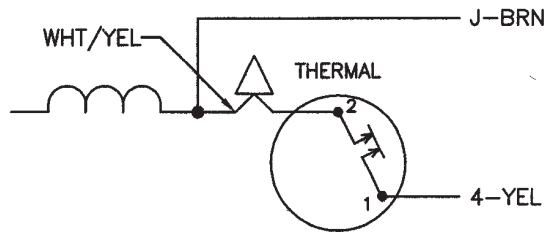

Figure 23. Electric Motor Wiring Diagram

EXPLANATION OF CODE IN REMARKS COLUMN

How to read the marks and remarks used in this parts book.

Section 1: Items Found In the “Remarks” Column

Serial Numbers-Where indicated, this indicates a serial number range (inclusive) where a particular part is used.

Model Number-Where indicated, this shows that the corresponding part is utilized only with this specific model number or model number variant.

Section 2: Items Found In the “Remarks” Column

Serial Numbers-Where indicated, this indicates a serial number range (inclusive) where a particular part is used.

Model Number-Where indicated, this shows that the corresponding part is utilized only with this specific model number or model number variant.

Section 3: Items Found In the “Items Number” Column

All parts with same symbol in the number column, *, #, +, %, or ■, belong to the same assembly or kit.

Note: If more than one of the same reference number is listed, the last one listed indicates newest (or latest) part available.

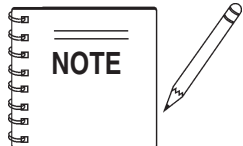

The contents of this parts catalog are subject to change without notice.

MS15H/MS15E MIXER — SUGGESTED SPARE PARTS

MS15H/MS15E MIXER 1 TO 3 UNITS WITH HONDA GX160K1HX2 ENGINE

Qty.	P/N	Description
2	491010	RUBBER LATCH ASSY.
1	508473	V-BELT, ELECTRIC MOTOR A37
1	80000-008	WIPER KIT
3	9807956846	SPARK PLUG HONDA 5.5HP
3	17210ZE1505	ELEMENT, AIR HONDA 5.5 HP
1	28462ZH8003	ROPE, RECOIL STARTER, HONDA 5.5 HP

MS15H/MS15E MIXER — NAMEPLATE AND DECALS

NAMEPLATE AND DECALS.

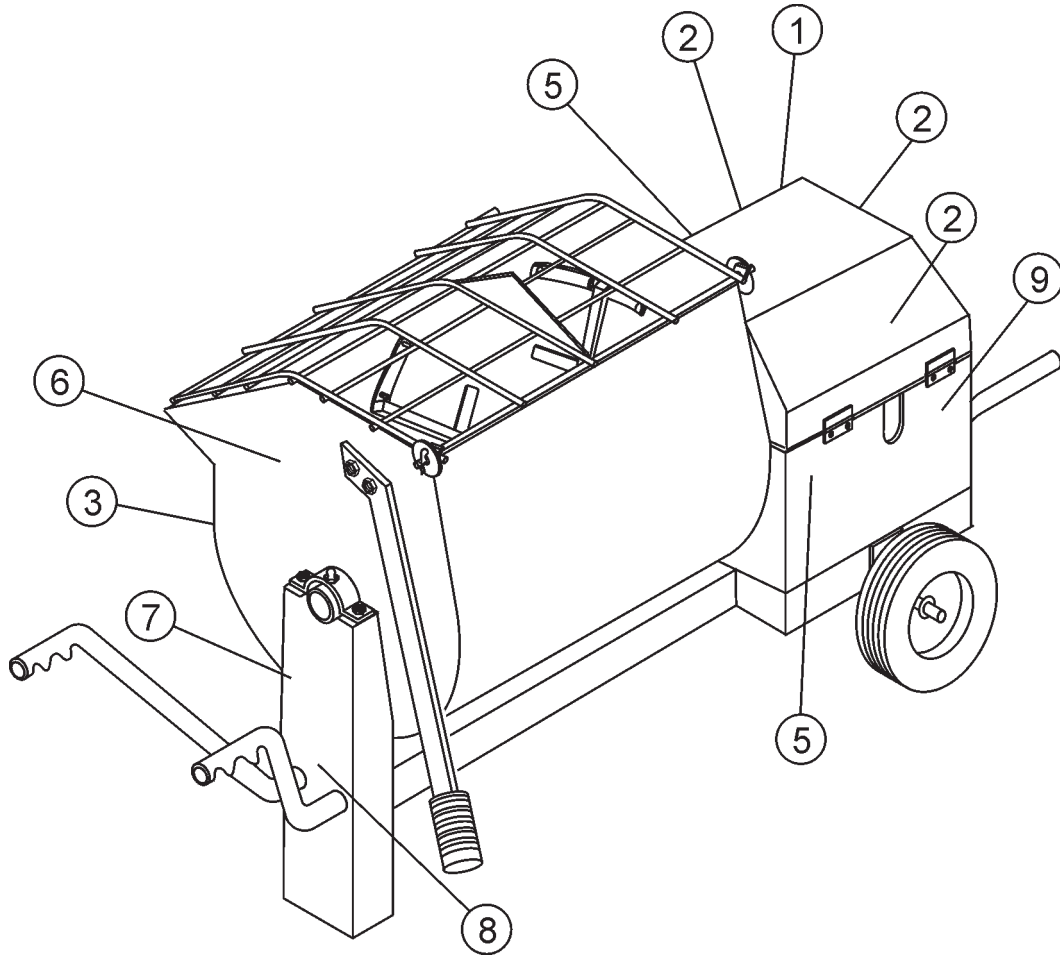

MS15H/MS15E MIXER — NAMEPLATE AND DECALS

NAMEPLATE AND DECALS.

<u>NO</u>	<u>PART NO</u>	<u>PART NAME</u>	<u>QTY.</u>	<u>REMARKS</u>
1*	504713	DECAL: WARNING READ	1	
2*	510165	DECAL: STOW (MULTIQUIP) SMALL	3	
3*	512527	DECAL: STOW (MULTIQUIP) BIG	1	
5*	DCL160A	DECAL: WARNING ENGINE SHUTOFF	2	
6*	25259-001	DECAL: WARNING GRATE	1	
7		DECAL: NAMEPLATE	1 CONTACT MQ PARTS DEPT.
8*	13118	DECAL: POWDER COATED	1	
9*	DCL160	DECAL: PROP. 65 WARNING	1	

SEE DECAL ILLUSTRATIONS ON PAGE 13.

MS15H/MS15E MIXER — STEEL TUB ASSY.

STEEL TUB ASSY.

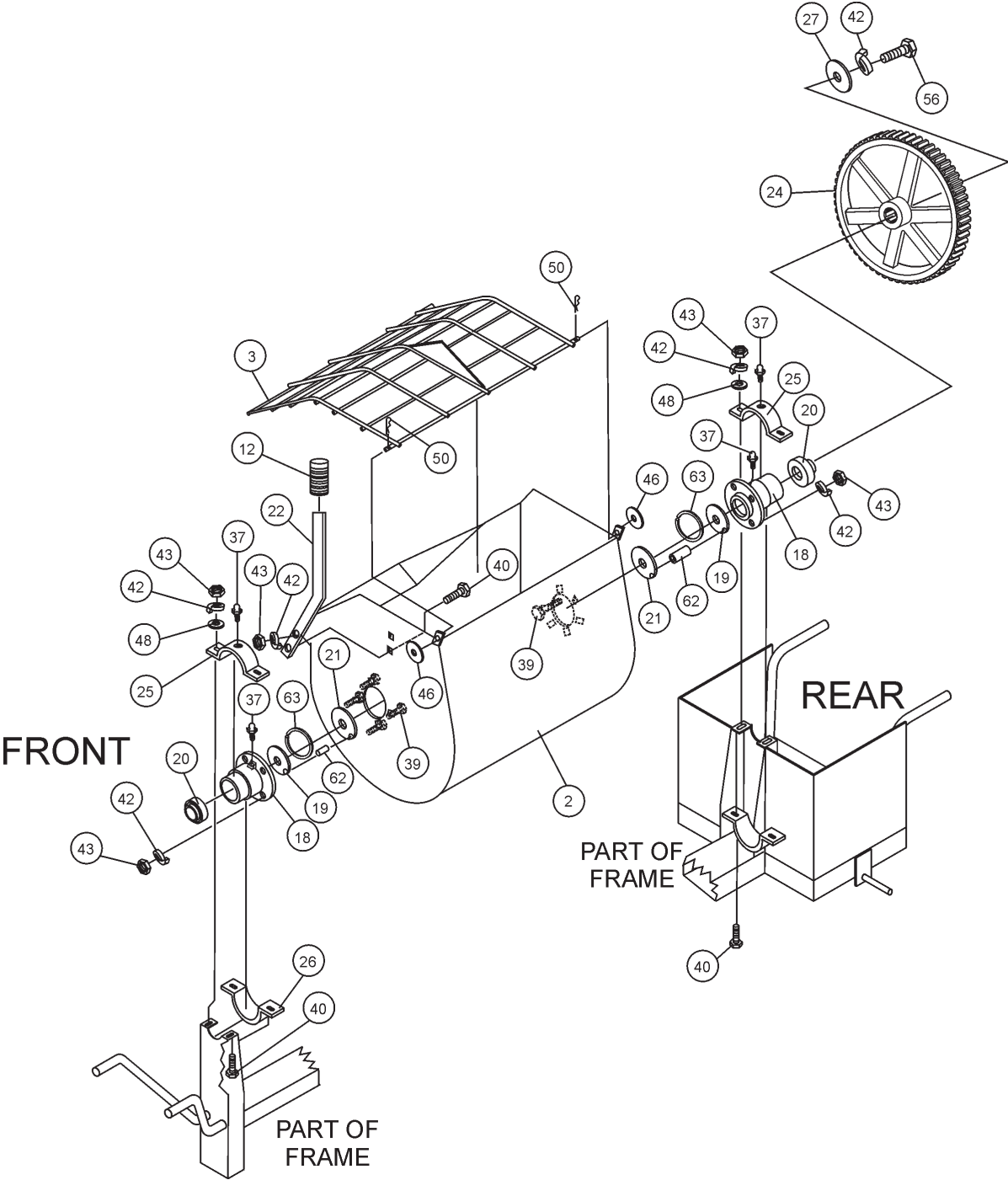

MS15H/MS15E MIXER — STEEL TUB ASSY

STEEL TUB ASSY.

<u>NO</u>	<u>PART NO</u>	<u>PART NAME</u>	<u>QTY.</u>	<u>REMARKS</u>
2*	26084-352	DRUM	1	
3	26085-351	GRATE	1	
12	23180-001	HAND GRIP	1	
18*	19728-001	TRUNNION	2	
19+*	19722-001	SHAFT SEAL	2	
20*	33177-001	SEALED BEARING	2	
21+*	33044-001	SHAFT SEAL	2	
22	25492-001	DUMP LEVER	1	
24*	33048-001	MAIN GEAR	1	
25	33084-001	BEARING HALF - UPPER	2	
26	33084-002	BEARING HALF - LOWER	2	
27*	18937-001	LARGE WASHER	1	
37*	07745-001	GREASE FITTING	4	
39*	17985-008	CARRIAGE BOLT 3/8 - 16 X 1	8	
40	17985-010	CARRIAGE BOLT 3/8 - 16 X 1-1/4	6	
42*	07029-006	LOCKWASHER 3/8	15	
43*	07033-006	HEX NUT 3/8 - 16	14	
46	07030-008	FLATWASHER 1/2	2	
48	07030-006	FLATWASHER 3/8	4	
50	07028-055	COTTER PIN 5/32 X 1	2	
56*	06501-008	HEX HEAD CAP SCREW 3/8 - 16 X 1	1	
62*	07594-012	ROLL PIN 3/16 X 3/4	2	
63*	19721-001	RETAINING RING	2	
	25648-501	SHAFT SEAL KIT	1	INCLUDES ITEMS W/+
	26083-502	DRUM ASSY. W/SHAFT MAIN GEAR	1	INCLUDES ITEM W/*, ALSO INCLUDES PADDLE SHAFT P/N 29062-351

MS15H/MS15E MIXER — PADDLE SHAFT ASSY.

PADDLE SHAFT ASSY.

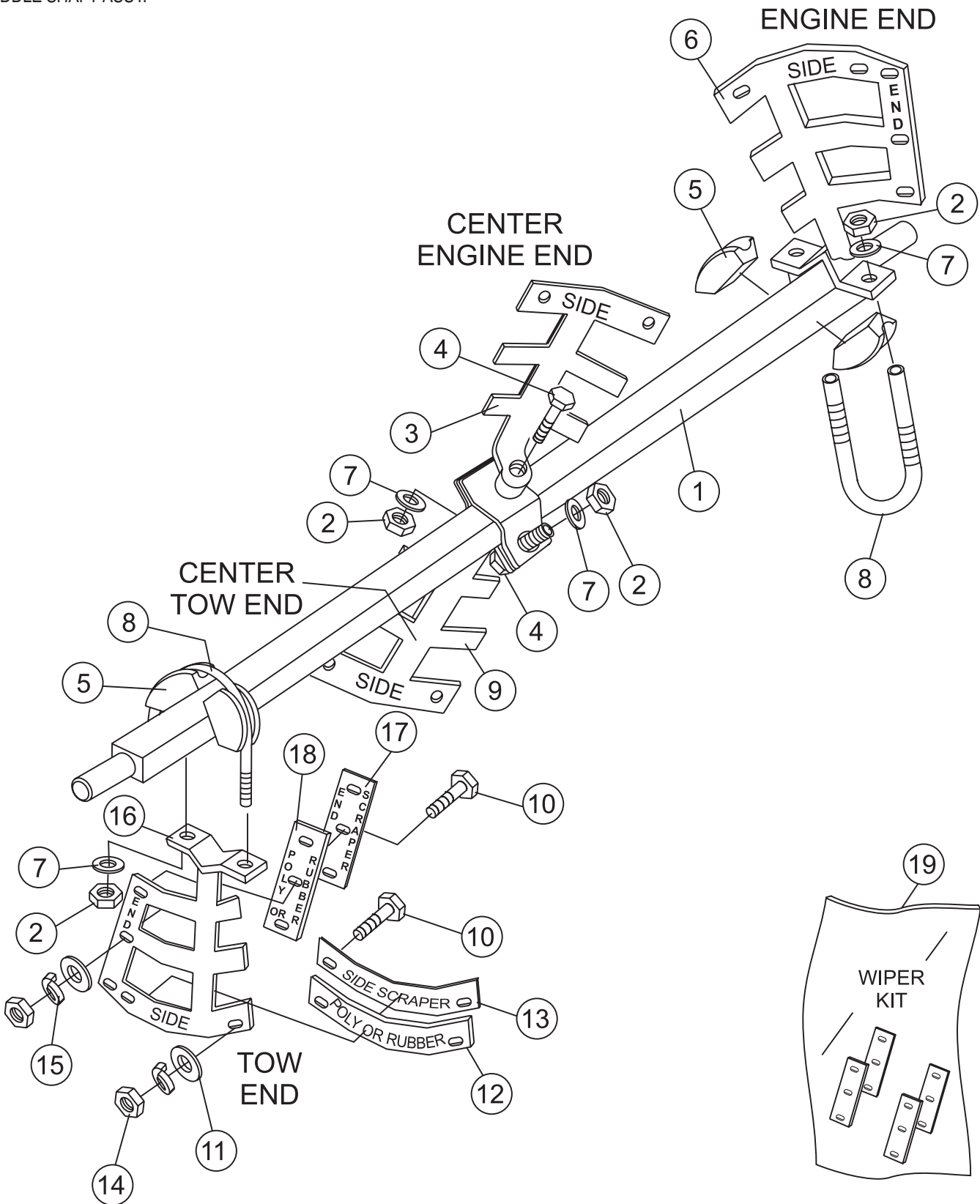

MS15H/MS15E MIXER — PADDLE SHAFT ASSY.

PADDLE SHAFT ASSY.

<u>NO.</u>	<u>PART NO.</u>	<u>PART NAME</u>	<u>QTY.</u>	<u>REMARKS</u>
1	29062-351	PADDLE SHAFT	1	
2	492584	NUT, LOCK 1/2"	6	
3	530181C	PADDLE ARM, CENTER ENGINE END	1	
4	492400	SCREW, HHC 1/2"-13 X 3-1/2	2	
5	EM200292	INSERT, PADDLE ARM	4	
6	530180C	PADDLE ARM, ENGINE END	1	
7	504322	WASHER, FLAT 1/2"	6	
8	EM200297	U-BOLT, END PADDLES	2	
9	530179C	PADDLE ARM, CENTER TOW END	1	
10	505196	SCREW, HHC 5/16-18 X 1-3/4 G5	12	
11	3019092	WASHER, FLAT 3/8"	12	
12*	514725	BLADE, SIDE, RUBBER	4	
13	514726	BLADE, SIDE, SCRAPPER	4	
14	1456	NUT, HEX FINISH 3/8-16" NC G5	12	
15	0166A	WASHER, LOCK 3.8"	12	
16	530182C	PADDLE ARM, TOW END	1	
17	530201	BLADE ,SCRAPPER END	2	
18*	33017-001	BLADE, RUBBER END	2	
19	80000-008	KIT, WIPERS	1	INCLUDES ITEMS W/*

MS15H/MS15E MIXER — FRAME ASSY.

FRAME ASSY.

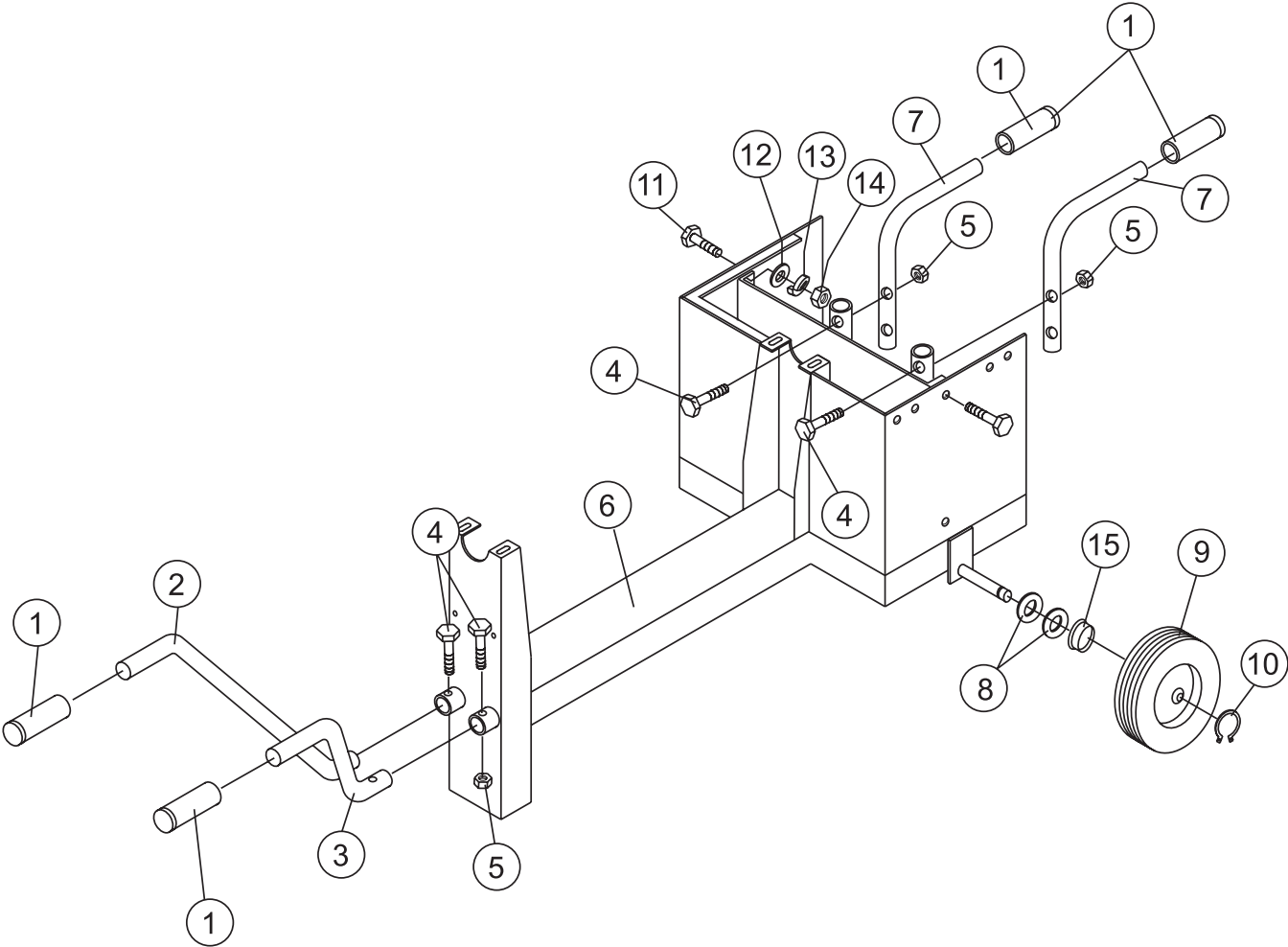

MS15H/MS15E MIXER — FRAME ASSY.

FRAME ASSY.

<u>NO</u>	<u>PART NO</u>	<u>PART NAME</u>	<u>QTY.</u>	<u>REMARKS</u>
1	EM98195	GRIP, RUBBER BLACK	4	
2	530467	HANDLE, FRONT-LEFT	1	
3	530226	HANDLE, FRONT-RIGHT	1	
4	492381	SCREW, 3/8 NC 2-1/2 G5	6	
5	EM969013	NUT, NYLOCK	6	
6	530168	FRAME	1	
7	530166	HANDLE BACK	2	
8	501299	WASHER, FLAT	4	
9	491002	WHEEL , TIRE ASSY.	2	
10	490957	SNAP RING 5100-100	2	
11	492356	BOLT, 1/4" X 3/4"	4	
12	504451	WASHER, FLAT 1/4"	4	
13	2101402	WASHER, LOCK 1/4"	4	
14	492561	NUT, HEX HEAD 1/4"-20	4	
15	513699	BUSHING	2	

MS15H/MS15E MIXER — ENGINE COVER ASSY.

ENGINE COVER ASSY.

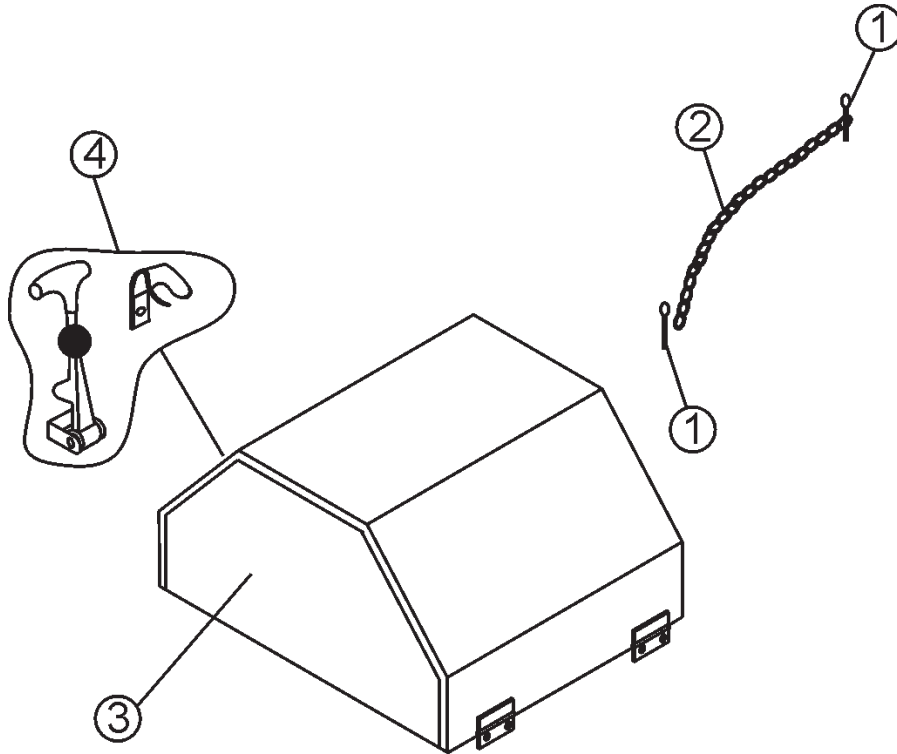

MS15H/MS15E MIXER — ENGINE COVER ASSY.

ENGINE COVER ASSY.

<u>NO</u>	<u>PART NO</u>	<u>PART NAME</u>	<u>QTY.</u>	<u>REMARKS</u>
1	07028-057	COTTER PIN 5/32 x 1/2	2	
2	18604-005	RETAINER CHAIN	1	
3	26922-351	ENGINE HOUSE ASSY.	1	
4	491010	LATCH ASSY.	1	

MS15H/MS15E MIXER — HONDA ENGINE ASSY.

HONDA ENGINE ASSY.

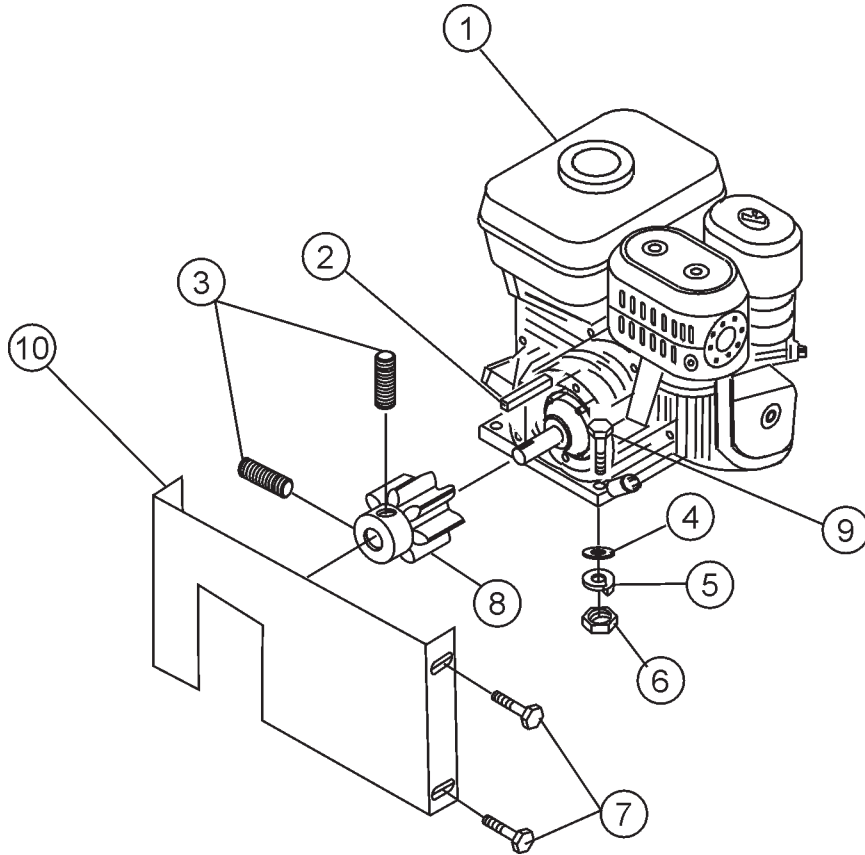

MS15H/MS15E MIXER — HONDA ENGINE ASSY.

HONDA ENGINE ASSY.

<u>NO</u>	<u>PART NO</u>	<u>PART NAME</u>	<u>QTY.</u>	<u>REMARKS</u>
1	GX160K1HX2	ENGINE-5.5 H.P.HONDA	1	REPLACES 22052-501
2	10057-016	SQUARE KEY 3/16 x 1-1/2	1	
3	18941-004	SOCKET SET SCREW 1/4-20 x1/4	2	
4	07030-005	FLATWASHER 5/16	4	
5	07029-005	LOCKWASHER 5/16	4	
6	07033-005	HEX NUT 5/16 -18	4	
7	06499-006	CAP SCREW 1/4-20 x 3/4	4	
8	33054-001	PINION GEAR	1	
9	06500-012	CAP SCREW 5/16 - 18 x 1-1/2	4	
10	26921-001	GEAR GUARD	1	

MS15H/MS15E MIXER — ELECTRIC MOTOR ASSY.

ELECTRIC MOTOR ASSY.

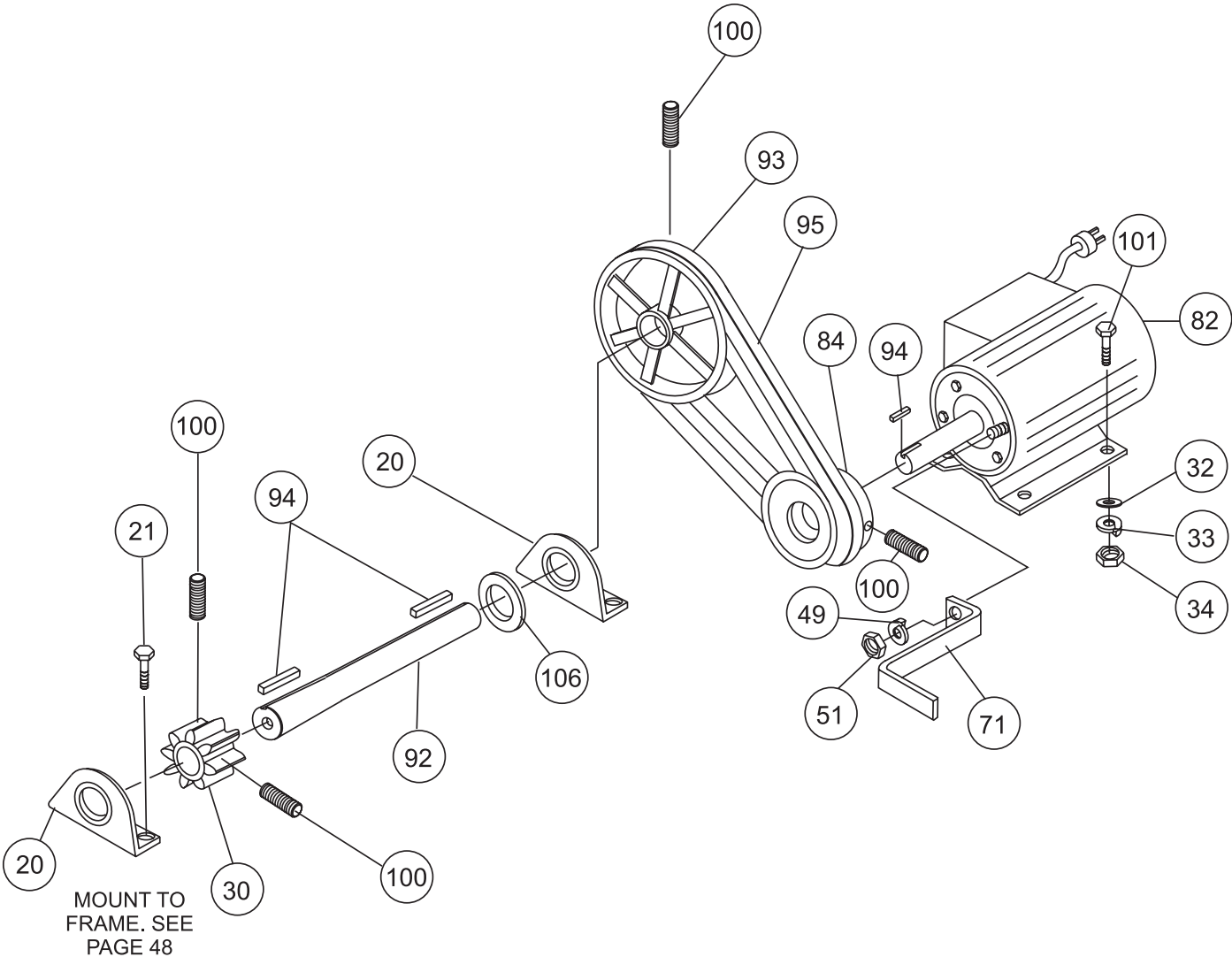

MS15H/MS15E MIXER — ELECTRIC MOTOR ASSY.

ELECTRIC MOTOR ASSY.

<u>NO</u>	<u>PART NO</u>	<u>PART NAME</u>	<u>QTY.</u>	<u>REMARKS</u>
20	33060-001	PILLOW BLOCK	2	
21	17985-010	CARRIAGE BOLT 3/8-16 x 1-1/4	4	
30	33054-001	DRIVE PINION GEAR	1	
32	07030-005	FLAT WASHER 5/16	4	
33	07029-005	LOCK WASHER 5/16	4	
34	07033-005	HEX NUT 5/16-18	4	
49	07029-004	LOCKWASHER 1/4	6	
51	07033-004	NUT, HEX 1/4-20	6	
71	26044-001	BRACKET	1	
82	22743-002	MOTOR & CONTROL ASSY. 1.0 HP	1	
84	512518	DRIVE PULLEY	1	
92	19867-001	SHAFT	1	
93	512466	DRIVEN PULLEY	1	
94	10057-016	SQUARE KEY 3/16 x 1-1/2	3	
95	508473	V-BELT, A-37	1	
100	18941-004	SOCKET SET SCREW 1/4-20 x1/4	4	
101	06500-008	CAP SCREW 5/16-18 x 1	4	
106	07030-012	FLATWASHER 3/4	1	

HONDA GX160K1HX2 ENGINE — CYLINDER HEAD ASSY.

CYLINDER HEAD ASSY.

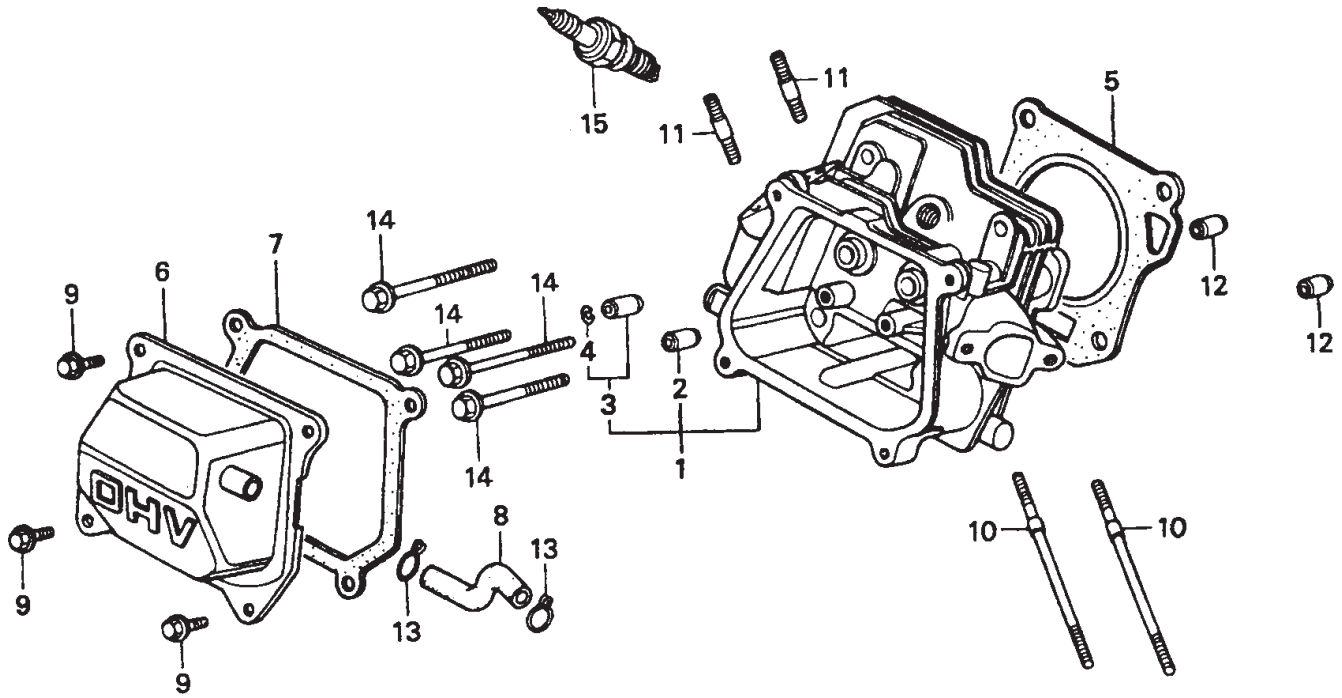

HONDA GX160K1HX2 ENGINE — CYLINDER HEAD ASSY.

CYLINDER HEAD ASSY.

<u>NO</u>	<u>PART NO</u>	<u>PART NAME</u>	<u>QTY.</u>	<u>REMARKS</u>
1	12210ZH8000	CYLINDER HEAD, COMP	1	INCLUDES ITEMS W/*
2*	12204ZE1306	GUIDE, IN. VALVE (OVER SIZE)	1	
3*	12205ZE1315	GUIDE, EX. VALVE (OS)	1	
4	12216ZE5300	CLIP, VALVE GUIDE	1	
5	12251ZF1800	GASKET, CYLINDER HEAD	1	
6	12310ZE1010	COVER COMP, HEAD	1	
7	12391ZE1000	GASKET, CYLINDER HEAD COVER	1	
8	15721ZH8000	TUBE, BREATHER	1	
9	90016ZE1000	BOLT, FLANGE 6X13	4	
10	90043ZE1020	BOLT, STUD 6X109	2	
11	90047ZE1000	BOLT, STUD 8X32	2	
12	9430110160	PIN A, DOWEL 10X16	2	
14	957230806000	BOLT, FLANGE 8X60	4	
15	9807956846	PLUG, SPARK (BPR6ES NGK)	1	
	9807956855	PLUG, SPARK (W20EPR-U ND)	1	

HONDA GX160K1HX2 ENGINE — CYLINDER BARREL ASSY.

CYLINDER BARREL ASSY.

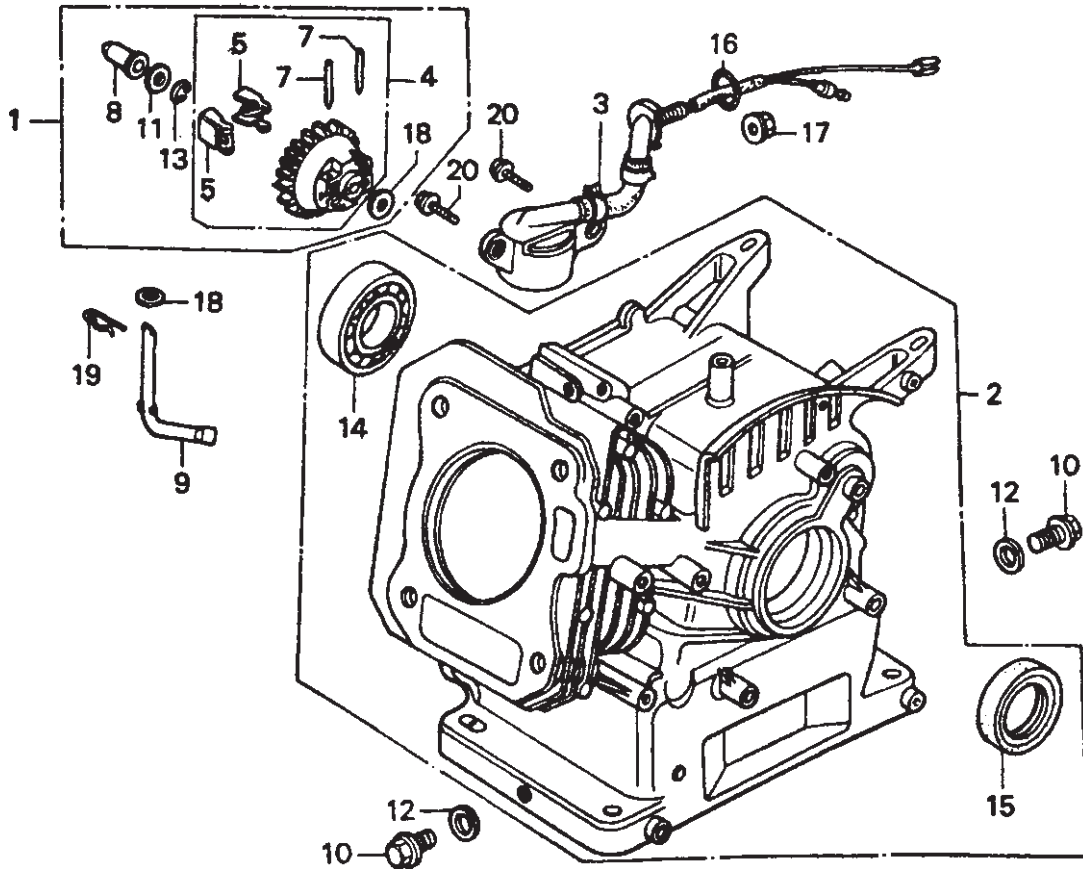

HONDA GX160K1HX2 ENGINE — CYLINDER BARREL ASSY.

CYLINDER BARREL ASSY.

<u>NO</u>	<u>PART NO</u>	<u>PART NAME</u>	<u>QTY.</u>	<u>REMARKS</u>
1	06165ZE1000	GOVERNOR KIT	1	INCLUDES ITEMS W/*
2	12000ZH8811	CYLINDER ASSY. BARREL OIL ALERT	1	INCLUDES ITEMS W%
3	15510ZE1023	SWITCH ASSY. OIL LEVEL	1	
4*	16510ZE1000	GOVERNOR ASSY.	1	INCLUDES ITEMS/W#
5*#	16511ZE1000	WEIGHT, GOVERNOR	2	
7*#	16513ZE1000	PIN, GOVERNOR WEIGHT	2	
8*	16531ZE1000	SLIDER, GOVERNOR	1	
9	16541ZE1000	SHAFT, GOVERNOR ARM	1	
10	90131ZE1000	BOLT, DRAIN PLUG	2	
11*	90451ZE1000	WASHER, THRUST 6MM	1	
12	90601ZE1000	WASHER, DRAIN PLUG 10.2MM	2	
13*	90602ZE1000	CLIP, GOVERNOR HOLDER	1	
14%	91001ZF1003	BEARING, RADIAL BALL(6205)	1	
15%	91202883005	OIL SEAL 25x41x6	1	
16	91353671003	O-RING 14MM ARAI	1	
17	9405010000	NUT, FLANGE 10MM	1	
18,*	9410106800	WASHER, PLAIN, 6MM	2	
19	9425108000	PIN, LOCK, 8MM	1	
20	957010601200	BOLT, FLANGE 6 x 12	2	

HONDA GX160K1HX2 ENGINE — CRANKCASE COVER ASSY.

CRANKCASE COVER ASSY.

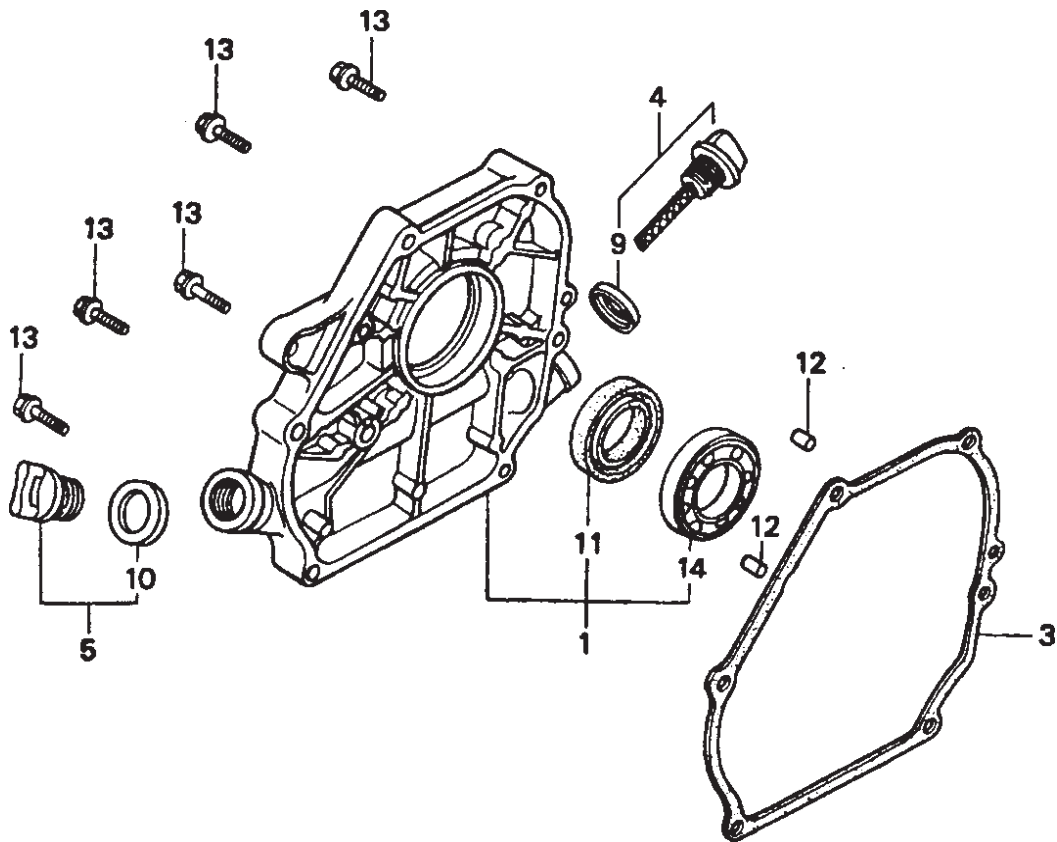

HONDA GX160K1HX2 ENGINE — CRANKCASE COVER ASSY.

CRANKCASE COVER ASSY.

<u>NO</u>	<u>PART NO</u>	<u>PART NAME</u>	<u>QTY.</u>	<u>REMARKS</u>
1	11300ZE1633	COVER ASSY, CRANKCASE (W TYPE) ...	1	INCLUDES ITEMS W/*
3	11381ZH8801	GASKET CASE COVER	1	
4	15600ZE1003	CAP ASSY, OIL FILLER	1	INCLUDES ITEMS W/#
5	15600ZG4003	CAP ASSY, OIL FILLER	1	INCLUDES ITEMS W/%
9#	15625ZE1003	GASKET, OIL FILLER CAP	1	
10%	15625ZE1003	GASKET, OIL FILLER CAP	1	
11*	91202883005	OIL SEAL, 25X41X6	1	
12	9430108140	PIN A, DOWEL 8X14	2	
13	957010803200	BOLT, FLANGE 8X32	6	
14*	961006205010	BEARING, RADIAL BALL, 6205	1	

HONDA GX160K1HX2 ENGINE — CRANKSHAFT ASSY.

CRANKSHAFT ASSY.

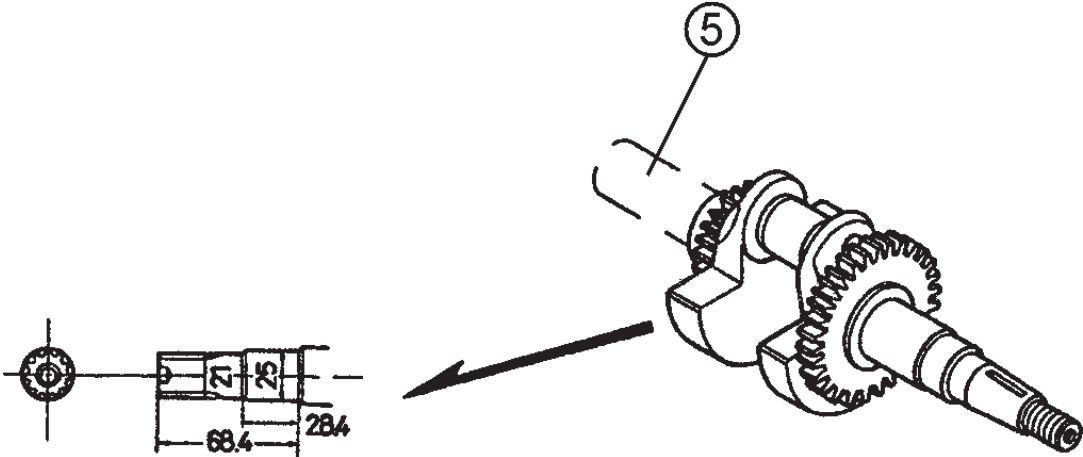

HONDA GX160K1HX2 ENGINE — CRANKSHAFT ASSY.

CRANKSHAFT ASSY.

<u>NO.</u>	<u>PART NO.</u>	<u>PART NAME</u>	<u>QTY.</u>	<u>REMARKS</u>
5	13310ZE1621	CRANKSHAFT (H- TYPE)	1	

HONDA GX160K1HX2 ENGINE — PISTON ASSY.

PISTON ASSY.

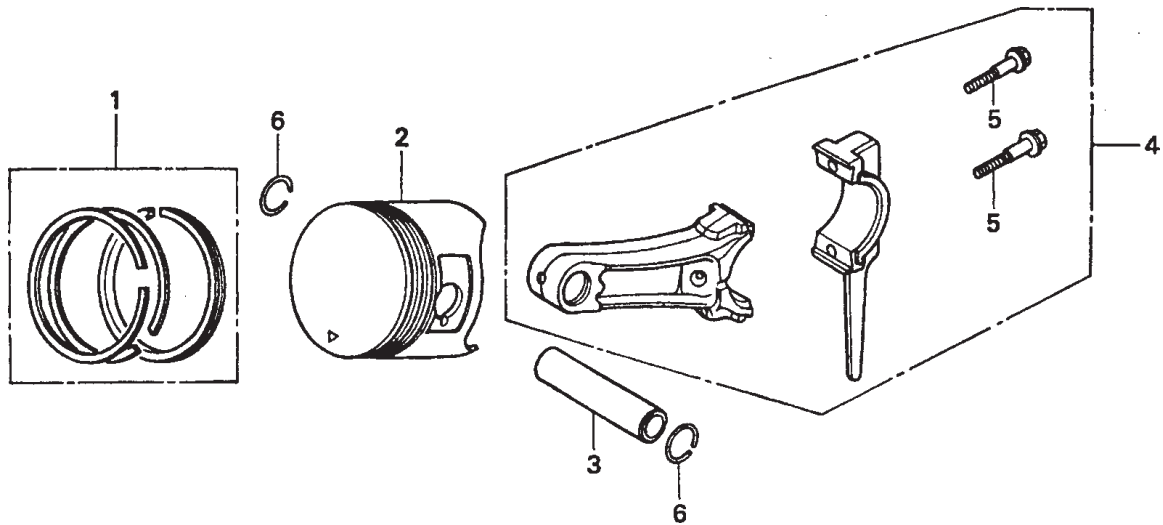

HONDA GX160K1HX2 ENGINE — PISTON ASSY.

PISTON ASSY.

<u>NO</u>	<u>PART NO</u>	<u>PART NAME</u>	<u>QTY.</u>	<u>REMARKS</u>
1	13010ZF1023	RING SET, PISTON (STD)	1	
1	13011ZF1023	RING SET, PISTON (0.25)	1	
1	13012ZF1023	RING SET, PISTON (0.50)	1	
1	13013ZF1023	RING SET, PISTON (0.75)	1	
2	13101ZH8000	PISTON (STD)	1	
2	13102ZH8000	PISTON (0.25)	1	
2	13103ZH8000	PISTON (0.50)	1	
2	13104ZH8000	PISTON (0.75)	1	
3	13111ZE1000	PIN, PISTON	1	
4	132A0ZE1000	ROD ASSY, CONNECTING	1	INCLUDES ITEMS W/*
5*	90001ZE1000	BOLT, CONNECTING ROD	2	
6	90551ZE1000	CLIP, PISTON PIN, 18MM	2	

HONDA GX160K1HX2 ENGINE — CAMSHAFT ASSY.

CAMSHAFT ASSY.

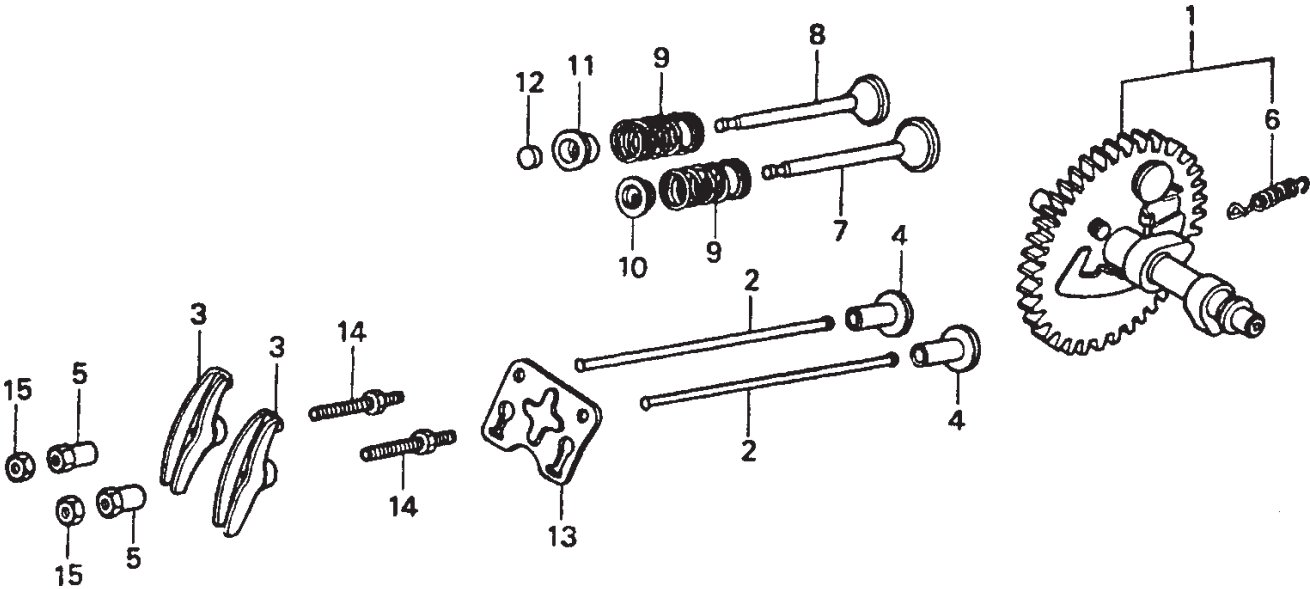

HONDA GX160K1HX2 ENGINE — CAMSHAFT ASSY.

CAMSHAFT ASSY.

<u>NO</u>	<u>PART NO</u>	<u>PART NAME</u>	<u>QTY.</u>	<u>REMARKS</u>
1	14100ZE1812	CAMSHAFT ASSY.	1	INCLUDES ITEMS W/*
2	14410ZE1010	ROD, PUSH	2	
3	14431ZE1000	ARM, VALVE ROCKER	2	
4	14441ZE1010	LIFTER, VALVE	2	
5	14451ZE1013	PIVOT, ROCKER ARM	2	
6*	14568ZE1000	SPRING, WEIGHT RETURN	1	
7	14711ZF1000	VALVE, IN.	1	
8	14721ZF1000	VALVE, EX.	1	
9	14751ZF1000	SPRING, VALVE	2	
10	14771ZE1000	RETAINER, IN. VALVE SPRING	1	
11	14773ZE1000	RETAINER, EX. VALVE SPRING	1	
12	14781ZE1000	ROTATOR, VALVE	1	
13	14791ZE1010	PLATE, PUSH ROD GUIDE	1	
14	90012ZE0010	BOLT, PIVOT	2	
15	90206ZE1000	NUT, PIVOT ADJUSTING	2	

HONDA GX160K1HX2 ENGINE — RECOIL STARTER ASSY.

RECOIL STARTER ASSY.

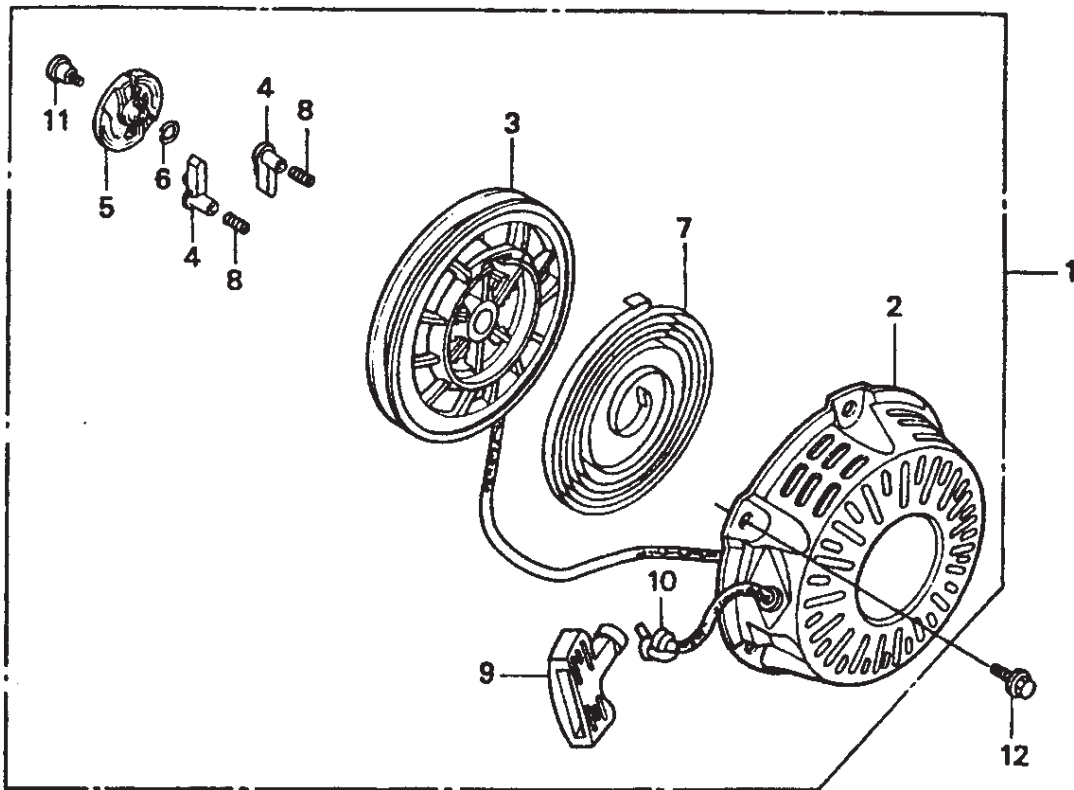

HONDA GX160K1HX2 ENGINE — RECOIL STARTER ASSY.

RECOIL STARTER ASSY.

NO	PART NO	PART NAME	QTY.	REMARKS
1	28400ZH8013ZB	STARTER ASSY, RECOIL NH1(BLACK) ...	1	INCLUDES ITEMS W/*
2*	28410ZH8003ZB	CASE COMP., RECOIL STARTER	1	
3*	28420ZH8013	REEL, RECOIL STARTER	1	
4*	28422ZH8013	RATCHET, STARTER	2	
5*	28433ZH8003	GUIDE, RATCHET	1	
6*	28441ZH8003	SPRING, FRICTION	1	
7*	28442ZH8003	SPRING, RECOIL STARTER	1	
8*	28443ZH8003	SPRING, RETURN	2	
9*	28461ZH8003	KNOB, RECOIL STARTER	1	
10*	28462ZH8003	ROPE, RECOIL STARTER	1	
11*	90003ZH8003	SCREW, SETTING	1	
12	957010600800	BOLT, FLANGE 6X8	3	

HONDA GX160K1HX2 ENGINE — FAN COVER ASSY.

FAN COVER ASSY.

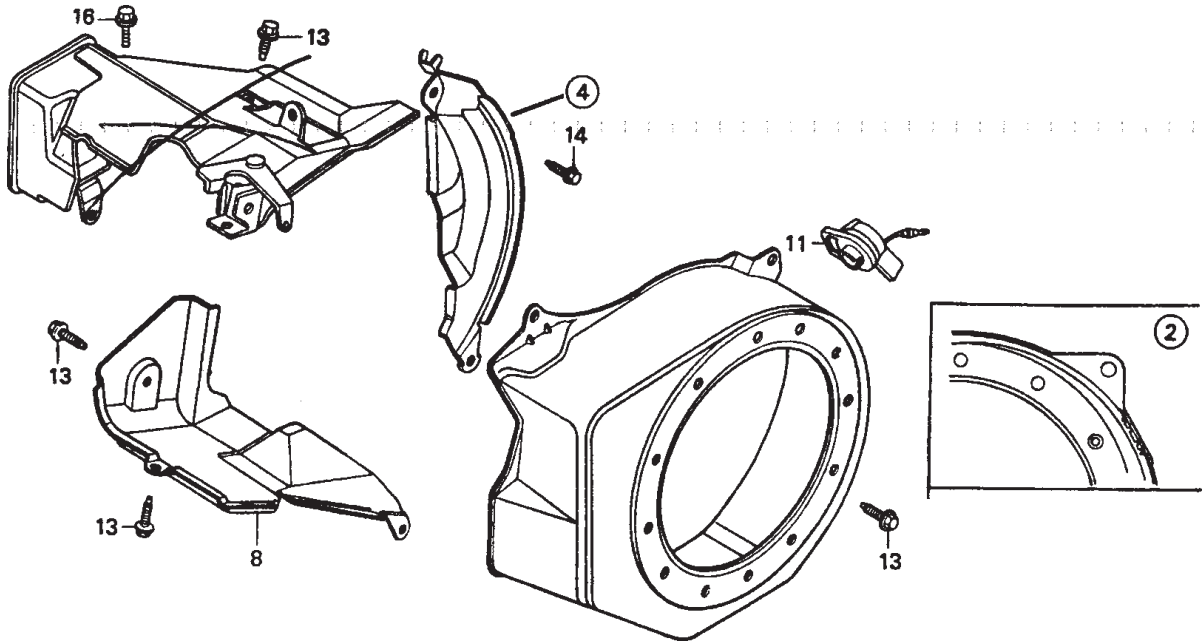

HONDA GX160K1HX2 ENGINE — FAN COVER ASSY.

FAN COVER ASSY.

<u>NO</u>	<u>PART NO</u>	<u>PART NAME</u>	<u>QTY.</u>	<u>REMARKS</u>
2	19610ZE1000ZC	COVER COMP., FAN NH1(BLACK)	1	
4	19612ZH8810	PLATE, SIDE (STD)	1	
7	90601ZH7013	CLIP, HARNESS	1	
8	19630ZH8000	SHROUD COMP.	1	
10	32197ZH8003	SUB-HARNESS	1	
11	36100ZE1015	SWITCH ASSY., ENGINE	1	
14	90022888010	BOLT, FLANGE 6X20	1	

HONDA GX160K1HX2 ENGINE — CARBURETOR ASSY.

CARBURETOR ASSY.

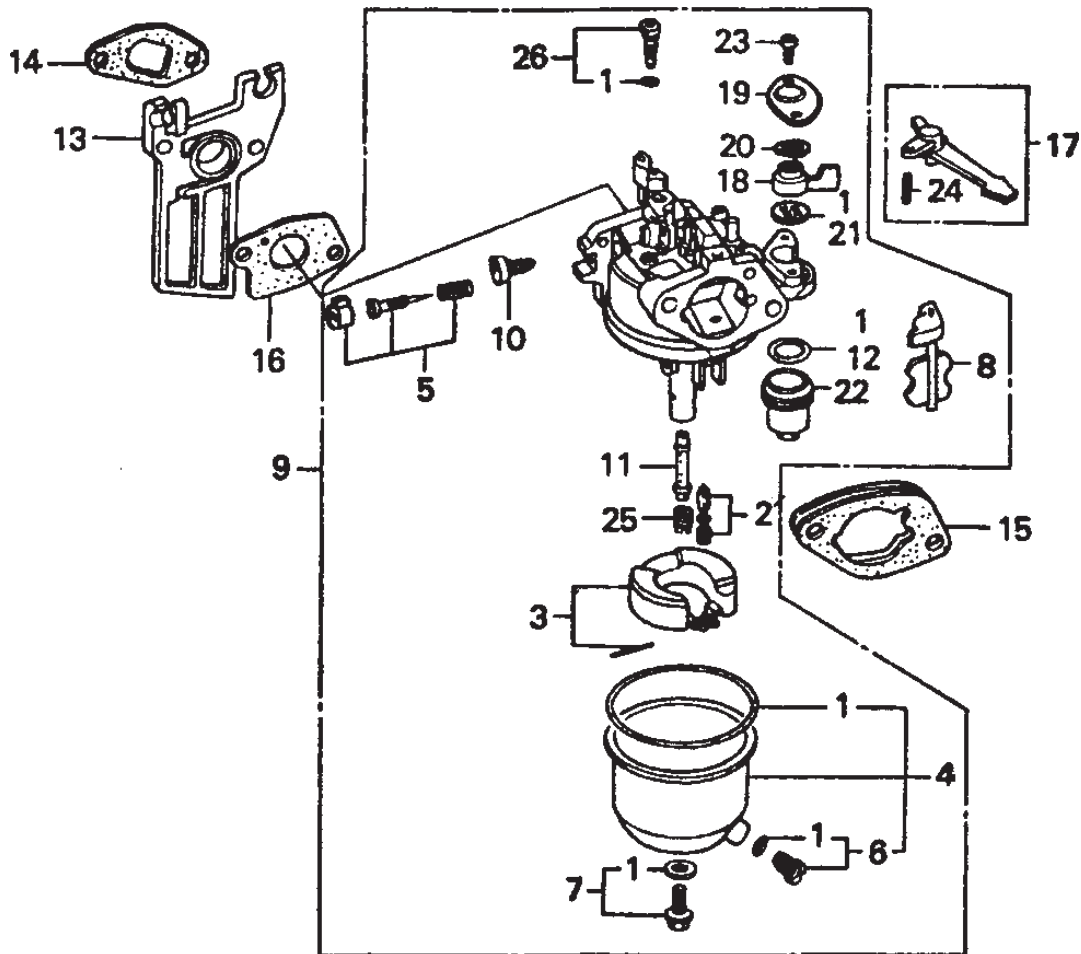

HONDA GX160K1HX2 ENGINE — CARBURETOR ASSY.

CARBURETOR ASSY.

NO	PART NO	PART NAME	QTY.	REMARKS
1*	16010ZE1812	GASKET SET	1	
2*	16011ZE0005	VALVE SET, FLOAT	1	
3*	16013ZE0005	FLOAT SET	1	
4*	16015ZE0831	CHAMBER SET, FLOAT	1	INCLUDES ITEMS W/%
5*	16016ZH7W01	SCREW SET	1	
6*%	16024ZE1811	SCREW SET DRAIN	1	
7*	16028ZE0005	SCREW SET B	1	
8*	16044ZE0005	CHOKE SET	1	
9	16100ZH8W51	CARBURETOR ASSY (BE65B)	1	INCLUDES ITEMS W/*
10*	16124ZE0005	SCREW, THROTTLE STOP	1	
11*	16166ZH8W50	NOZZLE, MAIN	1	
12*	16955283000	GASKET, FULL STRAINER CUP	1	
13	162111ZE1000	INSULATOR CARBURETOR	1	
14	16212ZH8800	GASKET, INSULATOR	1	
15	16220ZE1020	SPACER COMP. CARBURETOR	1	
16	16221ZH8801	GASKET CARBURETOR	1	
17	16610ZE1000	LEVER COMP., CHOKE (STD)	1	INCLUDES ITEMS W/#
18*	16953ZE1406	LEVER VALVE	1	
19*	16954ZE1812	PLATE LEVER SETTING	1	
20*	16956ZE1811	SPRING, PETCOCK LEVER	1	
21*	16957ZE1812	GASKET, PETCOCK	1	
22*	16967ZE0811	CUP, FUEL STRAINER	1	
23*	93500030060H	SCREW, PAN 3X6	2	
24#	9430520122	PIN, SPRING 2X12	1	
25*	99101ZH70650	JET, MAIN #65	1	
25*	99101ZH70680	JET, MAIN #68	1	
25*	99101ZH70700	JET, MAIN #70	1	
26*	99204ZE00350	JET SET, PILOT #35	1	

HONDA GX160K1HX2 ENGINE — AIR CLEANER ASSY.

AIR CLEANER ASSY.

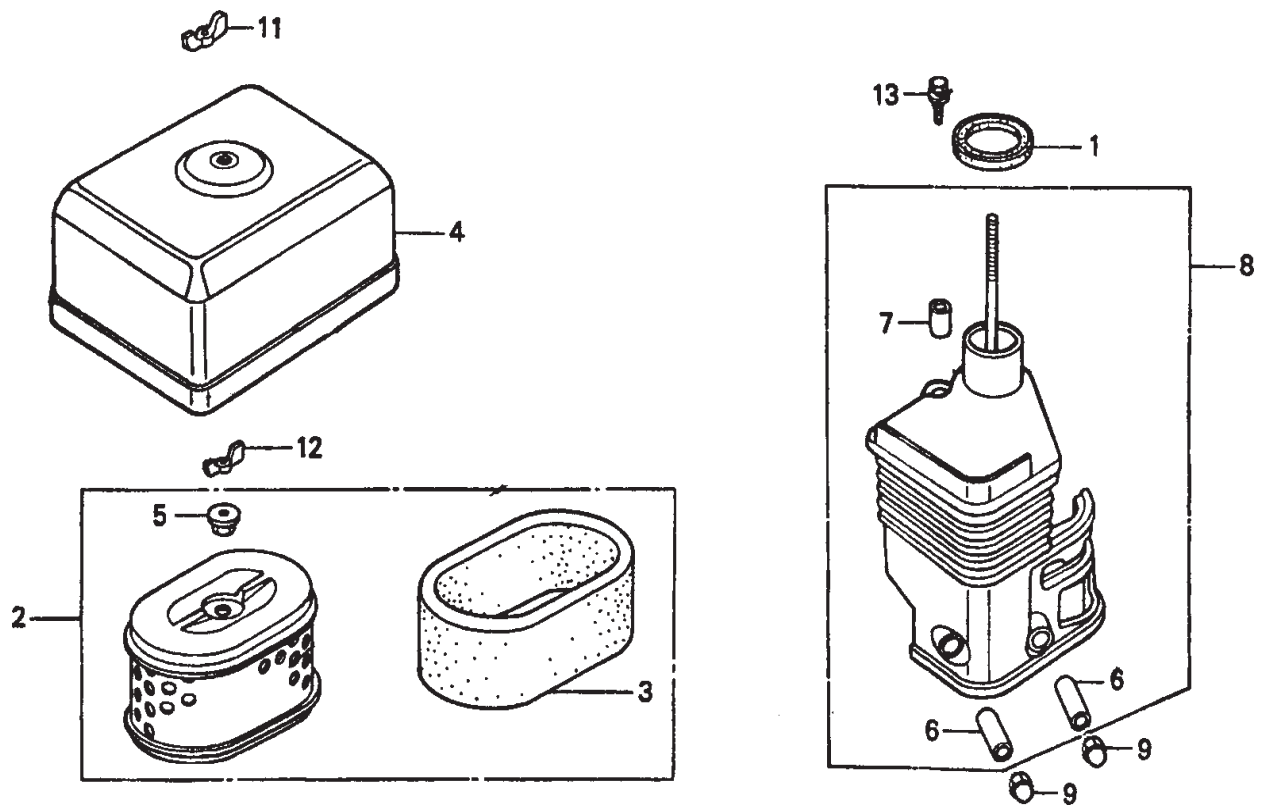

HONDA GX160K1HX2 ENGINE — AIR CLEANER ASSY.

AIR CLEANER ASSY.

<u>NO</u>	<u>PART NO</u>	<u>PART NAME</u>	<u>QTY.</u>	<u>REMARKS</u>
1	16271ZE1000	GASKET ELBOW	1	
2	17210ZE1505	AIR CLEANER ELEMENT DUAL	1	INCLUDES ITEMS W/#
3#	17218ZE1821	FILTER OUTER	1	
4	17230ZE1820	COVER AIR CLEANER DUAL	1	
5#	17232891000	GROMMET, AIR CLEANER	1	
6*	17238ZE7010	COLLAR, AIR CLEANER	1	
7*	17239ZE1000	COLLAR B, AIR CLEANER	1	
8	17410ZE1020	ELBOW COMP. AIR CLEANER	1	INCLUDES ITEMS W/*
9	90201415000	NUT CAP 6MM	2	
11	90325044000	NUT WING TOOL BOX SETTING	1	
12	90325044000	NUT WING TOOL BOX SETTING	1	
13	957010602000	BOLT FLANGE 6 x 20	1	

HONDA GX160K1HX2 ENGINE — MUFFLER ASSY.

MUFFLER ASSY.

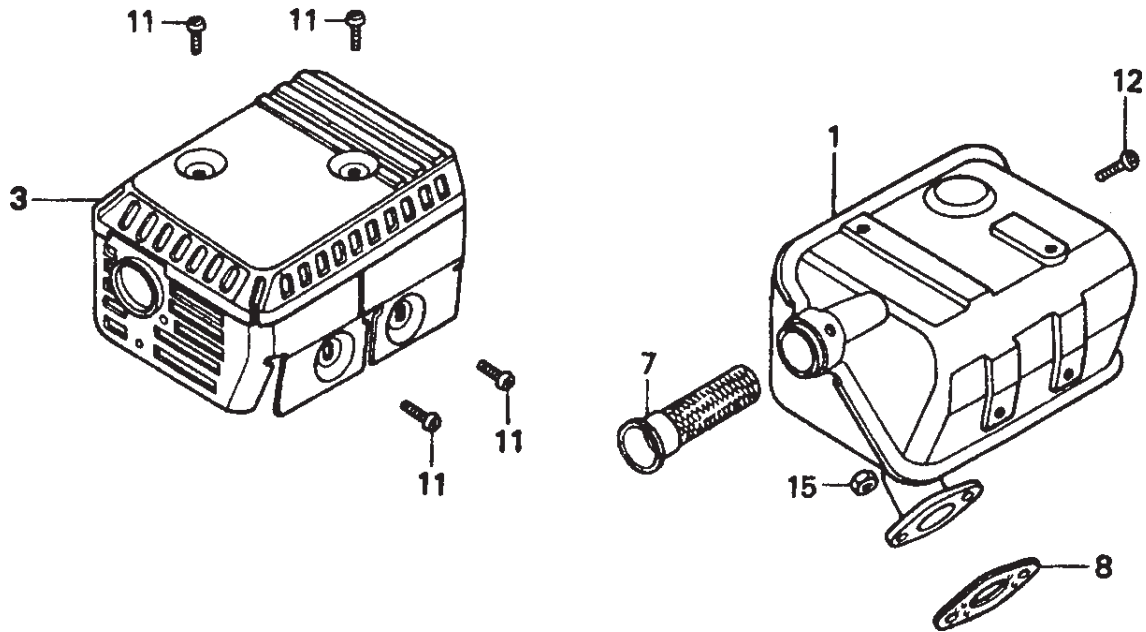

HONDA GX160K1HX2 ENGINE — MUFFLER ASSY.

MUFFLER ASSY.

<u>NO</u>	<u>PART NO</u>	<u>PART NAME</u>	<u>QTY.</u>	<u>REMARKS</u>
1	18310ZH8810	MUFFLER COMP.	1	
3	18320ZF1H01	PROTECTOR, MUFFLER	1	
7	18355ZE1000	ARRESTER, SPARK	1	
8	18381ZH8800	GASKET, MUFFLER	1	
11	90050ZE1000	SCREW, TAPPING 5X8	4	
12	90055ZE1000	SCREW, TAPPING 4X6	1	
15	94001080000S	NUT, HEX (8MM)	2	

HONDA GX160K1HX2 ENGINE — FUEL TANK ASSY.

FUEL TANK ASSY.

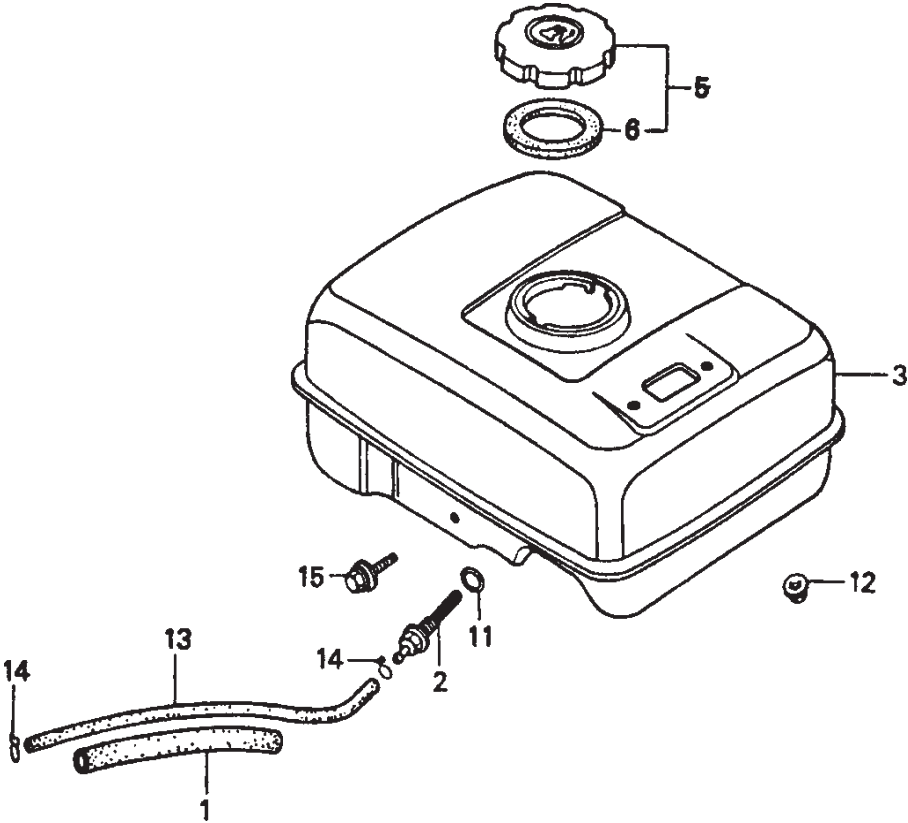

HONDA GX160K1HX2 ENGINE — FUEL TANK ASSY.

FUEL TANK ASSY.

<u>NO</u>	<u>PART NO</u>	<u>PART NAME</u>	<u>QTY.</u>	<u>REMARKS</u>
1	16854ZH8000	RUBBER, SUPPORTER	1	
2	16955ZE1000	JOINT, FUEL TANK	1	
3	17510ZE1020ZF	TANK COMP., FUEL NH1 (BLACK)	1	
5	17620ZH7013	CAP COMP., FUEL FILLER	1	INCLUDES ITEMS W/#
6#	17631ZH7003	GASKET, FUEL FILLER CAP	1	
11	91353671003	O-RING (14MM) ARAI	1	
12	9405006000	NUT, FLANGE (6MM)	2	
13	950014500840M	BULK HOSE, FUEL (4.5X8000) (4.5X140)	1	
14	9500202080	CLIP, TUBE (B8)	2	
15	957010602500	BOLT, FLANGE (6X25)	1	

HONDA GX160K1HX2 ENGINE — FLYWHEEL ASSY.

FLYWHEEL ASSY.

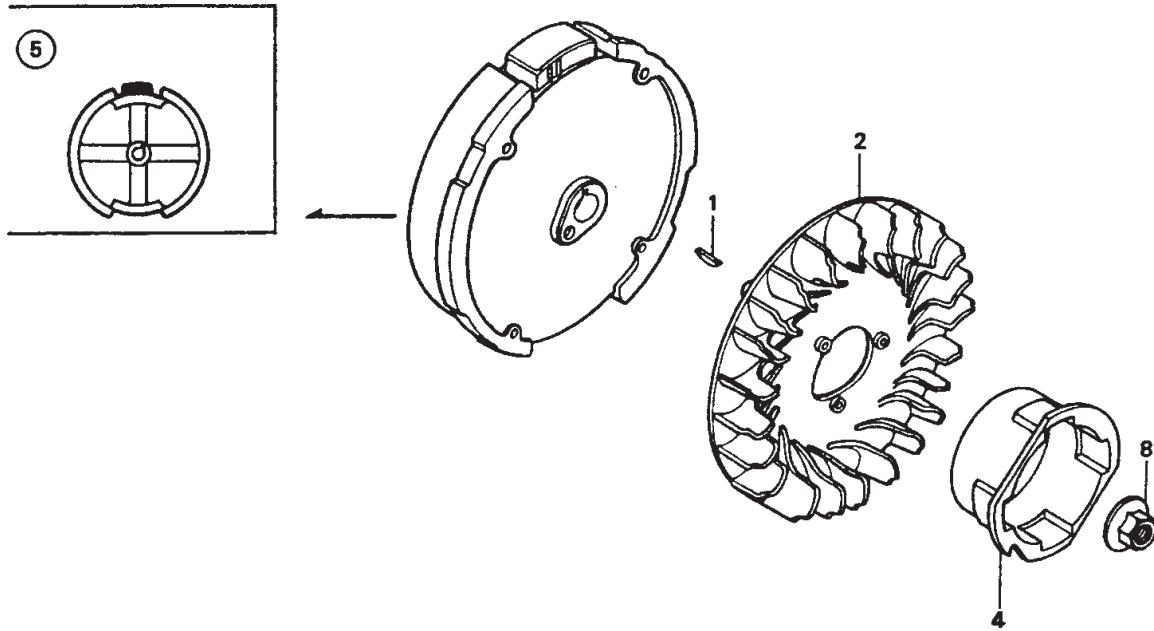

HONDA GX160K1HX2 ENGINE — FLYWHEEL ASSY.

FLYWHEEL ASSY.

<u>NO</u>	<u>PART NO</u>	<u>PART NAME</u>	<u>QTY.</u>	<u>REMARKS</u>
1	13331357000	KEY, SPECIAL WOOD RUFF, 25X18	1	
2	19511ZE1000	FAN, COOLING	1	
4	28451ZH8003	PULLEY STARTER	1	
5	31100ZE1000	FLYWHEEL COMP.	1	
8	90201878003	NUT, SPECIAL, 14MM	1	

HONDA GX160K1HX2 ENGINE — IGNITION COIL ASSY.

IGNITION COIL ASSY.

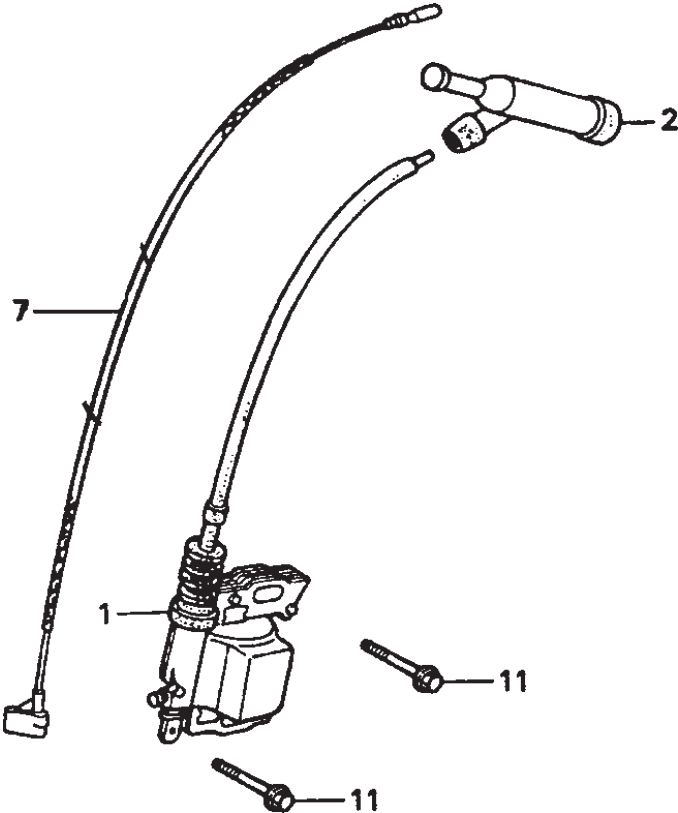

HONDA GX160K1HX2 ENGINE — IGNITION COIL ASSY.

IGNITION COIL ASSY.

<u>NO</u>	<u>PART NO</u>	<u>PART NAME</u>	<u>QTY.</u>	<u>REMARKS</u>
1	30500ZE1033	COIL ASSY., IGNITION	1	
2	30700ZE1013	CAP ASSY., NOISE SUPPRESSOR	1	
7	36101ZE1010	WIRE, STOP SWITCH (370MM)	1	
11	90121952000	BOLT, FLANGE, 6X25	2	

HONDA GX160K1HX2 ENGINE — CONTROL ASSY.

CONTROL ASSY.

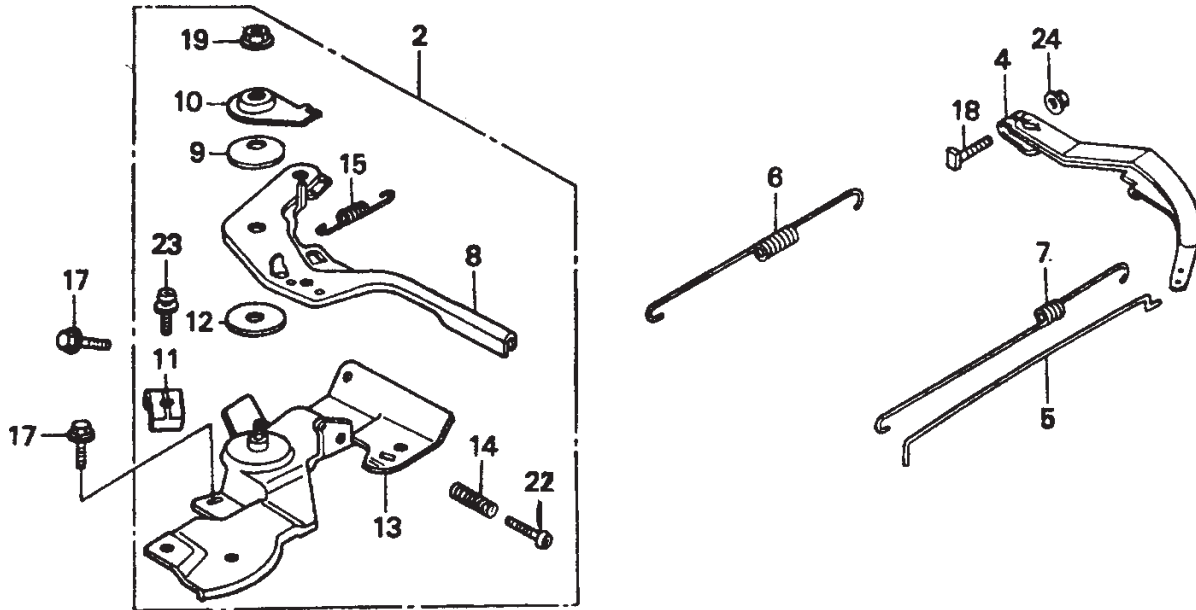

HONDA GX160K1HX2 ENGINE — CONTROL ASSY.

CONTROL ASSY.

<u>NO</u>	<u>PART NO</u>	<u>PART NAME</u>	<u>QTY.</u>	<u>REMARKS</u>
2	16500ZH8821	CONTROL ASSY., REMOTE	1	INCLUDES ITEMS W/*
4	16551ZE0010	ARM, GOVERNOR	1	
5	16555ZE1000	ROD, GOVERNOR	1	
6	16561ZE1020	SPRING, GOVERNOR	1	
7	16562ZE1020	SPRING, THROTTLE RETURN	1	
8*	16571ZH8000	LEVER, CONTROL	1	
9*	16574ZE1000	SPRING, LEVER	1	
10*	16575ZH8000	WASHER, CONTROL LEVER	1	
11*	16576891000	HOLDER, CABLE	1	
12*	16578ZE1000	SPACER, CONTROL LEVER	1	
13*	16580ZH8811	BASE COMP., CONTROL	1	
14*	16584883300	SPRING, CONTROL ADJUSTING	1	
15*	16592ZE1810	SPRING, CABLE RETURN	1	
17	90013883000	BOLT, FLANGE (6X12)	2	
18	90015ZE5010	BOLT, GOVERNOR ARM	1	
19*	90114SA0000	NUT, SELF- LOCK (6MM)	1	
22*	93500050250H	SCREW, PAN (5X25)	1	
23*	938930501600	SCREW WASHER (5X16)	1	
24	9405006000	NUT, FLANGE, 6MM	1	

HONDA GX160K1HX2 ENGINE — GEAR REDUCTION ASSY.

GEAR REDUCTION ASSY.

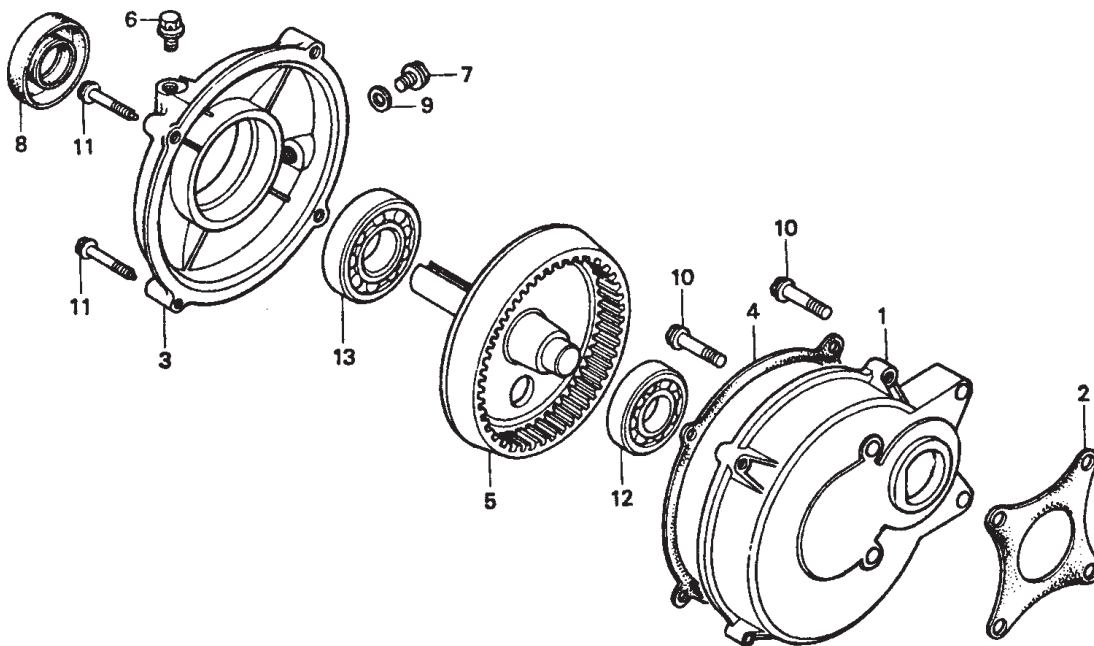

HONDA GX160K1HX2 ENGINE — GEAR REDUCTION ASSY.

GEAR REDUCTION ASSY.

<u>NO.</u>	<u>PART NO.</u>	<u>PART NAME</u>	<u>QTY.</u>	<u>REMARKS</u>
1	21521883741	CASE, REDUCTION	1	
2	21591ZH8740	GASKET, REDUCTION CASE	1	
3	21621883741	COVER, REDUCTION	1	
4	21692ZH8800	GASKET, REDUCTION COVER	1	
5	23710883740	SHAFT, P.T.O.	1	
6	90002883740	BOLT, BREATHING	1	
7	90131883000	BOLT, DRAIN PLUG	1	
8	91202883005	OIL SEAL, 25 x 41 x 6	1	
9	9410912000	WASHER, DRAIN PLUG	1	
10	957010803208	BOLT, FLANGE 8 x 32	1	
11	957010803500	BOLT, FLANGE 8 x 35	1	
12	961006204000	BEARING, RADIAL BALL 6204	1	
13	961006305000	BEARING, RADIAL BALL 6305	1	

HONDA GX160K1HX2 ENGINE — LABEL ASSY.

LABEL ASSY.

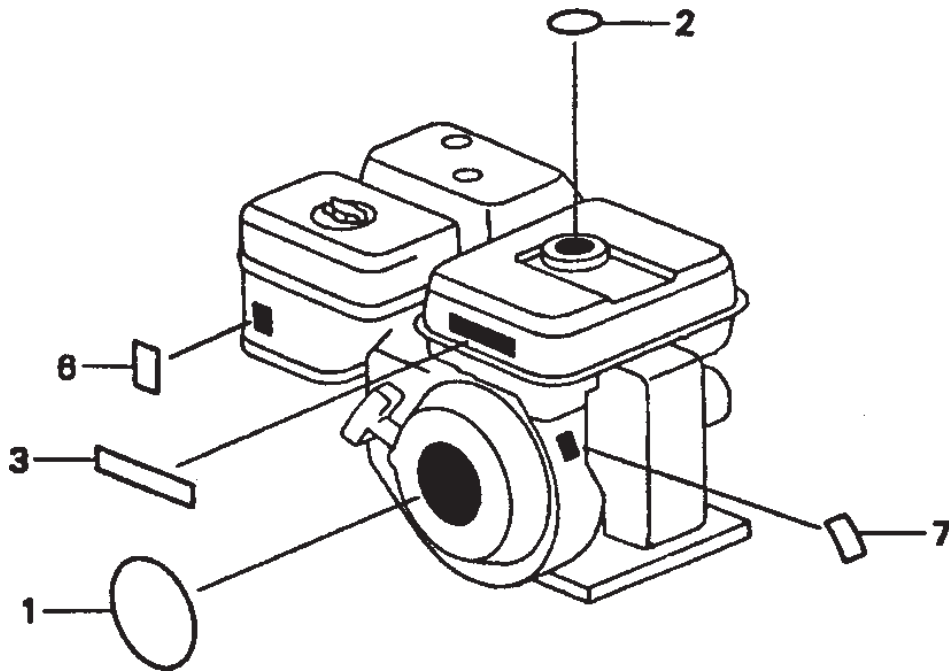

HONDA GX160K1HX2 ENGINE — LABEL ASSY.

ENGINE LABELS ASSY.

<u>NO.</u>	<u>PART NO.</u>	<u>PART NAME</u>	<u>QTY.</u>	<u>REMARKS</u>
1	87521ZH8020	ENBLEM 5.5	1	
3	87522ZH9000	LABEL, CAUTION	1	
6	87528ZE1810	MARK, CHOKE	1	
7	87530ZH8810	LABEL, SPECIFICATION (EXTERNAL)	1	
8	87532ZH8810	MARK, OIL ALERT (E)	1	
15	887586ZH7W00	LABEL, FUEL CAUTION	1	

STOW

A DIVISION OF MULTIQUIP INC.

Terms and Conditions of Sale STOW Construction Equipment

PAYMENT TERMS

Terms of payment for unit sales are 2% 15 days net 30 days from date of invoice unless otherwise specifically stated on our invoice. Parts invoices have terms of net 10 days. **Minimum parts billing is \$15.00 net.**

Applicable discounts will be computed on merchandise value only. Late charges will be assessed at prevailing rates. Cash discounts cannot be taken on current billings if any previously billed amounts are past due.

FREIGHT POLICY

Freight policy is established to offer customers every advantage possible. Due to bulk freight ratings on some equipment and other shipping considerations, freight policies differ by equipment type. Actual back freight may be charged for shipments originating from other than specified FOB warehouses. **See Freight Policy for details.**

All STOW domestic sales are FOB nearest available designated MQ/STOW warehouse. Export orders are ex-works factory located in Carson, CA or Boise, ID.

Additions to orders already shipped cannot be accepted for freight minimums.

Should STOW elect to make partial shipments of an order originally complying with the "freight allowed" requirements, transportation charges will be absorbed by STOW on any subsequent shipment applying to that order.

All other orders will be shipped collect or prepaid with charges added to the invoice. STOW's responsibility ceases when a signed manifest has been obtained from the carrier, and any claim for shortage or damage must be settled between the consignee and the carrier.

Parts: FOB Carson, California or Boise, Idaho. **See Freight Policy for details and additional discounts.**

DROP SHIPMENTS

STOW reserves the right to refuse Drop Shipments outside the normal service area of the purchasing dealer.

FIELD WAREHOUSES

Field Warehouses are currently located in California, Georgia, Idaho, Iowa, and New Jersey

SPECIAL EXPEDITING SERVICE

The higher of a \$35.00 surcharge or actual costs will be added to the invoice for special handling, including bus shipments, or in cases where STOW personnel must personally deliver the equipment or parts to the carrier.

RETURNED GOODS POLICY

Return shipments may be accepted and credit allowed, subject to the following provisions.

1. A Returned Material Authorization (RMA) must be approved by STOW prior to shipment. Approvals for returned goods must be with just cause and are at the sole discretion of STOW. A copy of the Authorization must accompany the shipment to the designated Warehouse.
2. Parts being returned must be listed as currently supplied on the current parts list.
3. Parts must be in new and resalable condition in the original package, with part numbers clearly marked.
4. Units and accessories must be current models in the latest price list and in new and resalable condition.
5. Special order items are not returnable for credit.
6. Credit on returned parts and units will be issued at actual dealer net price at time of purchase less 15% restocking charge.
7. All returned shipments are to be made to the STOW designated receiving point, freight prepaid at the sender's expense.

The sender will be notified of any material received that does not meet the above provisions. Such material will be held for 30 days from notification pending instructions. If a reply is not received within 30 days, the material will be returned to the sender at his expense with no credit issued.

PRICING, REBATES AND SPECIFICATIONS

Every effort will be made to provide adequate notice of changes; however, prices and equipment specifications are subject to change without notice.

Price changes are effective on a specific date and all orders received on or after that date will be billed at the revised price.

Rebates for price reductions and added charges for price increases will not be made for stock in dealer inventory at the time of a price change.

STOW reserves the right to quote and sell direct to Government agencies and to Original Equipment Manufacturer accounts who use our products as integral parts of their own products.

LIMITATION OF SELLER'S LIABILITY

STOW shall not be liable hereunder for damages in excess of the purchase price of the item with respect to which damages are claimed and in no event shall STOW be liable for loss of profit or good will or for any other special, consequential or incidental damages.

LIMITATION OF WARRANTIES

There are no warranties, express or implied, made by STOW hereunder on Products manufactured or distributed by it except the warranty against defects in material and

STOW

A DIVISION OF MULTIQUIP INC.

Atlanta • Boise • Newark • Quebec, Canada
Manchester, UK • Rio de Janeiro, BR • Puebla, MX

STOW CONSTRUCTION EQUIPMENT

POST OFFICE BOX 6254
CARSON, CALIFORNIA 90749
310-661-4242 • 877-BUY-STOW
FAX: 310-604-9237
E-MAIL: stow@stowmfg.com
www.stowmfg.com

OPERATION AND PARTS MANUAL

HERE'S HOW TO GET HELP

PLEASE HAVE THE MODEL AND SERIAL
NUMBER *ON-HAND* WHEN CALLING

STOW MAIN OFFICE

Post Office Box 6254
Carson, Ca 90749
Email: stow@multiquip.com
Internet: www.stowmfg.com

888-252-STOW
FAX: 310-537-1986

PARTS DEPARTMENT

800-427-1244
310-537-3700

FAX: 800-672-7877
FAX: 310-637-3284

SERVICE DEPARTMENT

800-421-1244
310-537-3700

FAX: 310-537-4259

TECHNICAL ASSISTANCE

800-478-1244

FAX: 310-631-5032

WARRANTY DEPARTMENT

800-421-1244, EXT. 279
310-537-3700, EXT. 279

FAX: 310-537-1173

SALES DEPARTMENT

310-661-4242
877-289-7869 (877-BUY-STOW)

FAX: 310-604-9237

Your Local Dealer is:

STOW **STOW CONSTRUCTION EQUIPMENT**
A DIVISION OF MULTIQUIP INC.
POST OFFICE BOX 6254
CARSON, CA 90749
888-252-STOW [888-252-7869]
FAX: 310-537-1986
E-mail: stow@multiquip.com
Internet: www.stowmfg.com