

# Digital Integrated Amplifier CA-S10

## Owner's Manual

Thank you for purchasing the CA-S10.  
In order to use the product in a safe manner, please read this Owner's Manual thoroughly before using.  
Also, keep this manual for future reference.



### Accessory Checklist

Before proceeding with the setup, make sure that the following accessory is included in the package. If it is missing, please contact the dealer whom you purchased the amplifier from, or Flying Mole Corp.

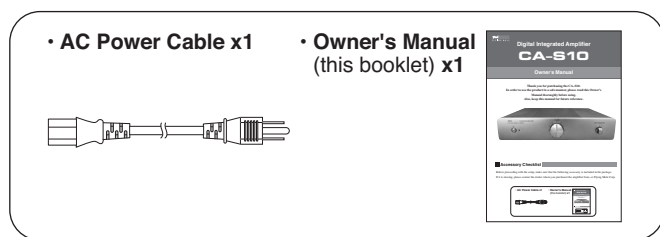

### Safety Instructions

THE APPARATUS IS NOT WATERPROOF. TO PREVENT FIRE OR SHOCK HAZARD, DO NOT EXPOSE THIS APPLIANCE TO RAIN OR MOISTURE AND DO NOT PUT ANY WATER SOURCE NEAR THIS APPARATUS, SUCH AS VASE, FLOWER POT, COSMETICS CONTAINER AND MEDICINE BOTTLE, ETC.

### IMPORTANT NOTICE

If this product is found to be the source of interference, which can be determined by turning the unit "OFF" and "ON", please try to eliminate the problem by using one of the following measures : Relocate either this product or the device that is being affected by the interference. Utilize power outlets that are on different branch (circuit breaker or fuse) circuits or install AC line filter/s.

In the case of radio or TV interference, relocate/reorient the antenna.  
If the antenna lead-in is 300 ohm ribbon lead, change the lead-in to coaxial type cable.  
If these corrective measures do not produce satisfactory results, please contact the local retailer authorized to distribute this type of product.  
If you can not locate the appropriate retailer, please contact Flying Mole Corporation.

## 2 Features

- **High Sound Quality Design**
  - Utilizing the acclaimed Bi-Phase PWM amplifier technology used in our CA-S3/DAD-M100pro
  - Independently powered dual monaural construction ensures both plentiful supplies of energy necessary for sources and maximum channel separation.
  - Equipped with ultra-high quality Single-pole preamplifier maintaining source quality at any volume position.
  - A newly-developed logic circuit for input signal selector to totally eliminate contacts on the signal path.
  - Frequency response of DC – 50kHz/8Ω is attained with DC amplifier circuit configuration.
- **Gorgeous Appearance**
  - Extra thick aluminum panel of maximum 10 mm (nonmagnetic material)
  - Aluminum (nonmagnetic material) hollow configuration body for high rigidity/superb vibration suppression
  - Machined solid Aluminum Knob
  - Gold Plated, Large gauge wire compatible Speaker Terminals
  - Gold Plated RCA pin jack: 3 source input, 1 pre out

## 1 Safety Instructions



**CAUTION**  
RISK OF ELECTRIC SHOCK  
DO NOT OPEN



**CAUTION** : TO REDUCE THE RISK OF ELECTRIC SHOCK, DO NOT REMOVE COVER (OR BACK). NO USER-SERVICEABLE PARTS INSIDE. REFER SERVICING TO QUALIFIED SERVICE PERSONNEL.



THIS SYMBOL INDICATES THAT DANGEROUS VOLTAGE CONSTITUTING A RISK OF ELECTRIC SHOCK IS PRESENT WITHIN THIS UNIT.



THIS SYMBOL INDICATES THAT THERE ARE IMPORTANT OPERATING AND MAINTENANCE INSTRUCTIONS IN THE OWNER'S MANUAL WITH THIS UNIT.

**WARNING** : To reduce the risk of fire or electric shock, do not expose this apparatus to rain or moisture.

### The important safety instructions

1. Read these instructions.
2. Keep these instructions.
3. Heed all warnings.
4. Follow all instructions.
5. Do not use this apparatus near water.
6. Clean only with dry cloth.
7. Do not block any ventilation openings. Install in accordance with the manufacturer's instructions.
8. Do not install near any heat sources such as radiators, heat registers, stoves, or other apparatus (including amplifiers) that produce heat.
9. Do not defeat the safety purpose of the polarized or grounding-type plug. A polarized plug has two blades with one wider than the other. A grounding type plug has two blades and a third grounding prong. The wide blade or the third prong are provided for your safety. If the provided plug does not fit into your outlet, consult an electrician for replacement of the obsolete outlet.
10. Protect the power cord from being walked on or pinched particularly at plugs, convenience receptacles, and the point where they exit from the apparatus.
11. Only use attachments/accessories specified by the manufacturer.
12. Use only with the cart, stand, tripod, bracket, or table specified by the manufacturer, or sold with the apparatus. When a cart is used, use caution when moving the cart/apparatus combination to avoid injury from tip-over.
13. Unplug this apparatus during lightning storms or when unused for long periods of time.
14. Refer all servicing to qualified service personnel. Servicing is required when the apparatus has been damaged in any way, such as power-supply cord or plug is damaged, liquid has been spilled or objects have fallen into the apparatus, the apparatus has been exposed to rain or moisture, does not operated normally, or has been dropped.



## 3 Component Names

### Front Panel

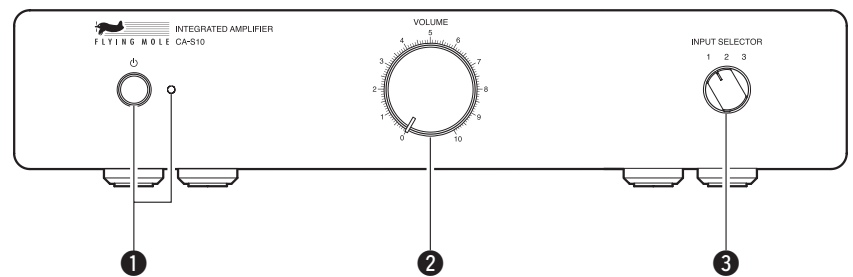

#### 1 Power Switch/Power Indicator

Used to turn the amplifier's power ON or OFF. The indicator lights when the power is turned ON.

#### 2 VOLUME Controller

Controls the output level. Setting the controller to "0" turns down the volume to the minimum.

#### 3 INPUT SELECTOR

Used to select a source to be played. Turn this knob to select one source among the LINE 1 – 3 connected to the INPUT jacks.

### Rear Panel

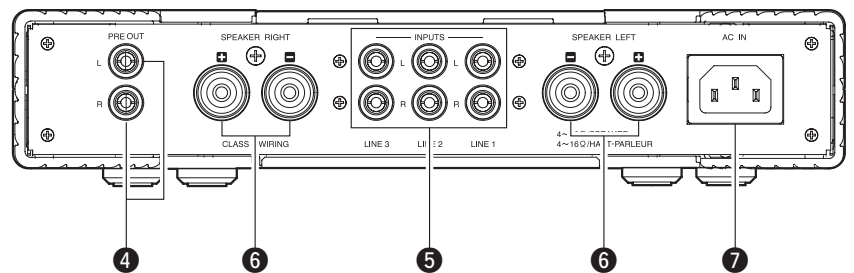

#### 4 PRE OUT Jacks

Used to add a power amplifier or a subwoofer. Connect to input jacks of a power amplifier or a subwoofer to the PRE OUT jacks on this product.

#### 5 INPUT Jacks

Used to connect the input sources. Connect to output jacks of sources CD Player, HDD Player, etc. to the LINE INPUT jacks on this product.

#### 6 SPEAKER Connectors

(\* Be sure to check polarity before connection)

#### 7 AC IN Jack

Used to connect the AC power cable. Connect the other end of the AC power cable to AC outlet.

## 4 Connections

### ■ Connecting Devices

- Make sure the power of all related equipments is turned off, when wiring and checking their polarity.
- Make sure that the cable is not shorted, when connecting the speaker cable.
- Connect the power cable after all connections are complete.
- This product should be placed close to the main source of electrical power (wall outlet in your house) and keep the power plug within reach.
- Jack names may be different from this manual.

\* Refer to the owner's manuals of the equipments to be connected as well.

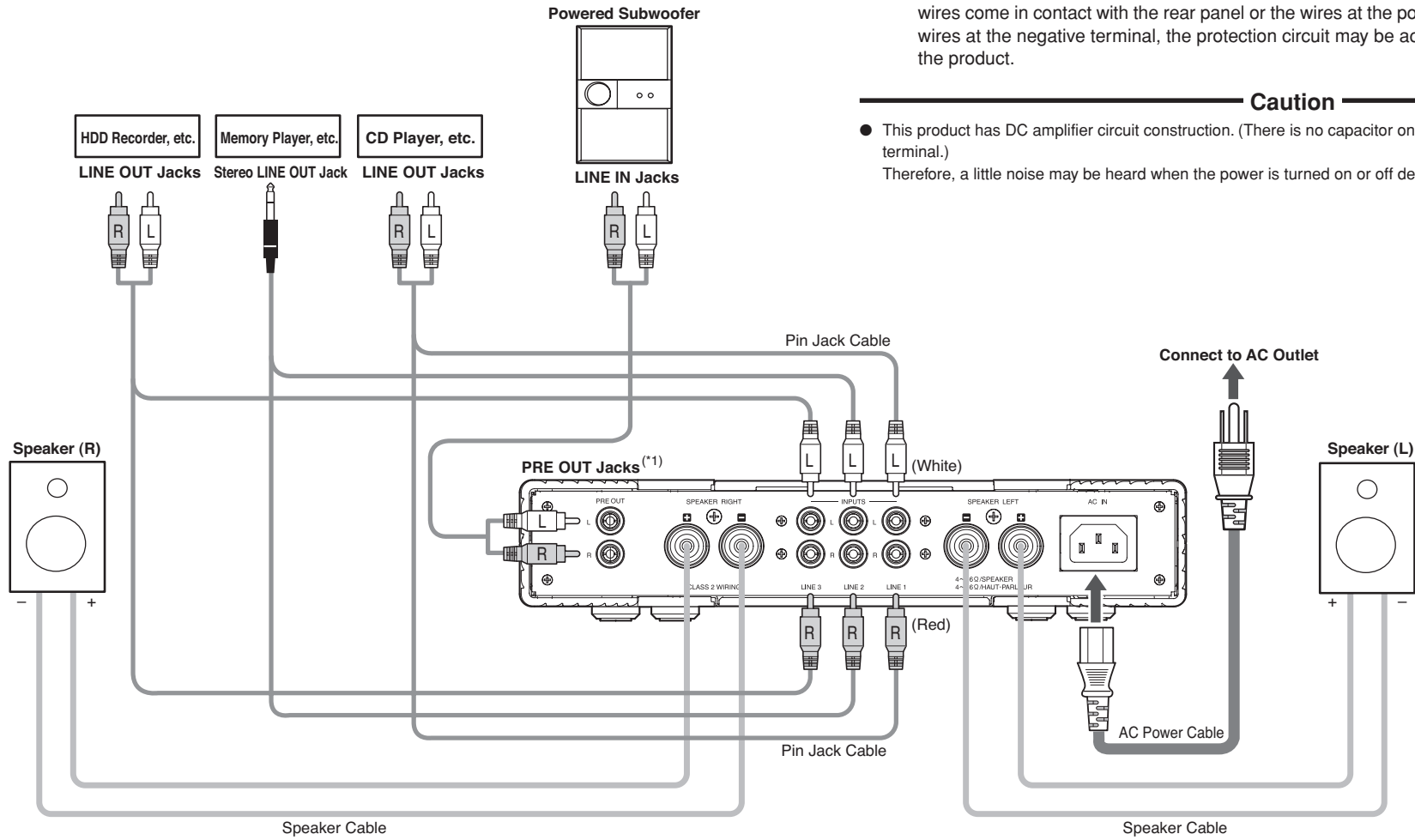

### ● Connecting a Speaker Cable

- ① Strip the cover of the cable by about 10 mm (3/8").
- ② Twist the wires until they are stranded securely.

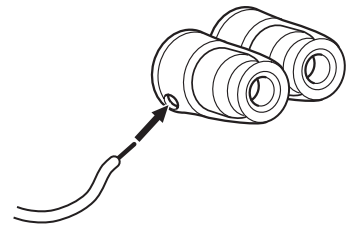
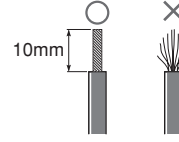

- ③ Turn a speaker connector counterclockwise to loosen it.
- ④ Insert the whole stranded wires of the cable and turn the speaker connector clockwise to tighten it.

\* Twist the wires of the speaker cable until they are stranded securely and take care not to leave any part of the stranded wires out of the speaker connector when connecting the speaker cable. If the wires come in contact with the rear panel or the wires at the positive terminal come in contact with the wires at the negative terminal, the protection circuit may be activated to stop the normal operation of the product.

### Caution

- This product has DC amplifier circuit construction. (There is no capacitor on signal path between input jack and speaker terminal.) Therefore, a little noise may be heard when the power is turned on or off depending on the connected device.

(\*1) To use the PRE OUT jacks, turn on this product before turning on the equipment connected to this product. When turning off the power, turn off the connected equipment before turning off this product.

## 5 Specifications

Rated Output	100W x 2 (8Ω) / 160W x 2 (4Ω)
Frequency Response	DC - 50kHz (0dB / -3dB) / (8Ω)
Total Harmonic Distortion	0.05% (@50W / 8Ω / 1kHz)
Channel Separation	>70dB (20kHz)
S/N Ratio	120dB (400-30kHz BPF)
Input Sensitivity	150mV (LINE in)
Input Impedance	10kΩ
Input Jack	RCA PIN (Unbalanced)
Conforming Speaker Impedance	4 - 16Ω
Power Consumption	64W / 4Ω (AC120V model), 61W / 4Ω (AC230V model)
Power Supply	AC 120V 60Hz (U.S.A. & Canadian model) / AC 230V 50Hz-
Use Environment	0°C - 40°C
Max. Dimensions	281(W) x 60(H) x 292(D) mm, 11-1/16" x 2-3/8" x 11-1/2"
Weight	4kg (8lbs 13oz)

\* Product Rating Label is on the bottom of the product.

\* Due to product improvement, specifications and/or product design are subject to change without notice.

## 6 Dimensions

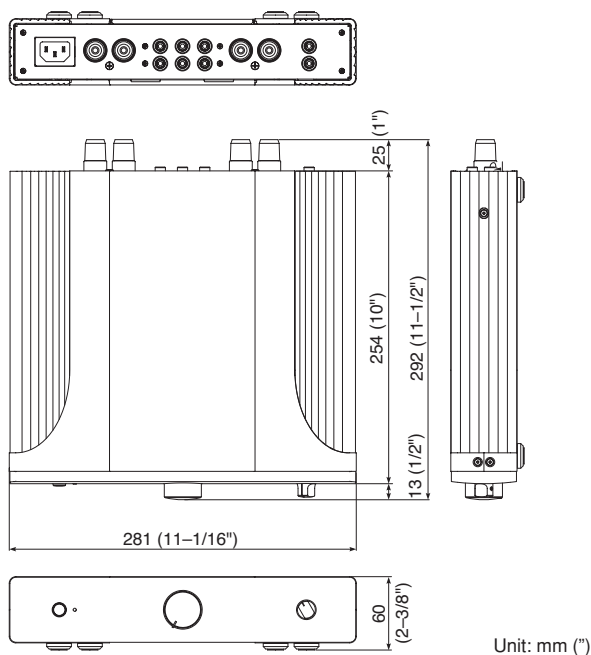

Unit: mm (")

## 7 Maintenance

Never use liquids such as benzene, thinners, etc., chemically treated cloths, and do not spray any aerosol type insecticides on the amplifier. Clean the case using only a soft, dry cloth. If the amplifier becomes soiled, mix a solution of water and a neutral detergent then dampen a soft cloth in the solution, wring out as much of the solution as possible, and clean the amplifier. Then use a soft, dry cloth to wipe the surface dry.

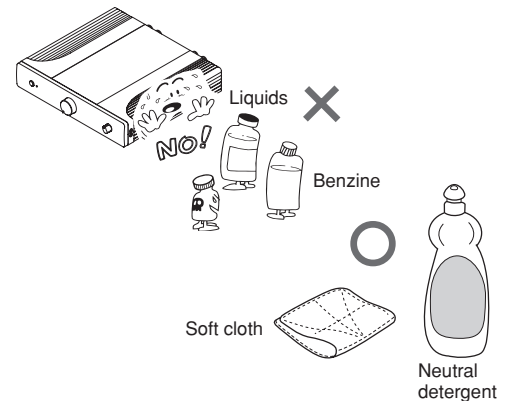

## 8 Limited Warranty

Warranty period is shown by the distributor in your market. In case defects occur during this period not due to mishandling or modification, please send the product together with proof of purchase to the dealer where you had purchased or to the following address if it is shown.

## 9 Questionnaire

There is a questionnaire in the "Support" section in our website. This is for helping us serve you better by developing new products. We look forward to your access to the following URL.

<http://www.flyingmole.co.jp>

### Protection of Personal Information

We use personal information in the questionnaire only for servicing you and for product development. We take safety measures to prevent leakage of the information as much as we can and we do not reveal it to a third party without your consent.

This document is printed with soy ink (an organic ink made from soy oil) on recycled paper. Environmentally friendly printed matter.



**FLYING MOLE CORPORATION**  
5199-1 Waji-cho, Hamamatsu 431-1115 Japan.  
Tel : +81-53-486-6030 Fax : +81-53-486-6033  
<http://www.flyingmole.co.jp> info@flyingmole.co.jp