

Project	Quantity	Item #
Model Specified:		CSI Section 11400

Fish/Poultry File Refrigerator Models/ Self-Contained



Model RFS126NUT



Model RFS226NUT

One & Two Section Reach-In Models With Drawers - 32" Deep



Stainless Exterior
& Interior

Four Drawer Model
Eight Drawer Model

RFS126NUT
RFS226NUT

The fish/poultry refrigerator models were especially designed for the storage of fresh fish and poultry, in a moist, refrigerated environment on a bed of crushed ice. This helps to preserve its taste and texture, cleansing it while melting, and at the same time minimizing both dehydration and bacteria growth.

One and two section reach-in models are available to meet differing capacity and floorspace requirements.

Standard Features

- Stainless Steel Exterior & Interior
- Self Closing Drawers
- Solar Digital Thermometer
- Special Interior Drawer Pans (16" W x 18⁷/₈" L x 6¹/₂" H), Includes A Perforated Bottom With A Weep Hole To Allow For Proper Drainage
- Guaranteed For Life Horizontal Work Flow Drawer Handles
- Set Of Four (4) 6" High Adjustable Stainless Steel Legs
- Cord & Plug Attached
- One Piece Louver Assembly
- Bell Trap Type Drain With 3/4" Pipe Connection (requires provision of a floor drain)
- Magnetic Drawer Gaskets
- 1 Year Parts and Labor Warranty
- 5 Year Compressor Warranty

Options & Accessories

- Stainless Steel Back
- Set Of Four (4) 6" High Heavy Duty Casters
- Two Year Service/Labor Warranty Available



Listed by Underwriters Laboratories Inc., to U.S. and Canadian safety standards and Listed by NSF International in accordance with ANSI/NSF 7.

Approval: _____



TRAULSEN
4401 BLUE MOUND RD.
PHONE 1 (800) 825-8220
Website: www.traulsen.com

FT. WORTH, TX 76106
FAX-MKTG. 1 (817) 624-4302

SECTION
7-2

Project	Quantity	Item #
Model Specified:		CSI Section 11400

Specifications

Construction, Hardware and Insulation

Cabinet exterior, including front, one piece sides, louver assembly and drawer faces are constructed of heavy gauge stainless steel. Cabinet interior is constructed of stainless steel. Exterior cabinet top, back and bottom are constructed of heavy gauge aluminized steel. Adjustable 6" high stainless steel legs are included.

Drawers are self closing on stainless steel slides. Guaranteed for life, work flow drawer handle is mounted horizontally over recess in drawer which limits protrusion from door face into aiseways. Screw on vinyl magnetic drawer gasket assures tight drawer seal. Both cabinet and drawers contain high density, non-CFC, foamed in place polyurethane insulation.

Proper Use

Fish or poultry products should be layered in the drawers, one layer of ice, followed by one layer of product, followed by another layer of ice, etc. The top layer of product should always be covered with a layer of fresh ice. Fish and poultry should never be mixed within the same unit. Fresh ice should be added periodically to maintain the proper ice volume and keep product covered. Product should never be kept in the drawers overnight, and removed for off hours storage. Special care should be taken to insure that the weep hole in the bottom of each drawer remains clear of obstruction to allow for proper drainage (product should not be allowed to rest in water).

The cabinet should be thoroughly cleaned on a daily basis to prevent the build-up of odors. Provision of a hose reel or hose connection nearby would be ideal for cleaning convenience.

DIMENSIONAL DATA	RFS126NUT	RFS226NUT
Gross capacity cu. ft.	19.3 (547 cu l)	39.6 (1122 cu l)
Net capacity of drawers cu. ft.	4.5 (127 cu l)	9.0 (255 cu l)
Depth - overall in.	29 (73.6 cm)	29 (73.6 cm)
Depth w/drawer extended in.	45 ⁵ / ₈ (115.8 cm)	45 ⁵ / ₈ (115.8 cm)
Length - overall in.	28 (71.1 cm)	52 ¹ / ₈ (132.4 cm)
Depth - cabinet only	26 (66.0 cm)	26 (66.0 cm)
Height - overall on 6" legs	83 ³ / ₄ (211.5 cm)	83 ³ / ₄ (211.5 cm)
Number of drawers	4	8
ELECTRICAL DATA		
Voltage	115/60/1	115/60/1
Feed wires with Ground	3	3
Full load amperes	6.7	6.7
Wattage ¹	547	547
Net Wt. lbs.	360 (163 kg)	560 (254 kg)
REFRIGERATION DATA		
Refrigerant	R-134a	R-134a
BTU/HR H.P. ²	2220 (1/3 HP)	2220 (1/3 HP)

NOTES

NOTE: Figures in parentheses reflect metric equivalents.

- 1= Wattage is determined by listed amps X listed volts X an average run time of 70% for refrigerators and 80% for freezers.
- 2= Based on a 90 degree F ambient and 20 degree F evaporator.
- 3= For approximate remote weights deduct 40 lbs. from respective net or gross weight. For other information on remote models, please refer to spec sheet 1 2-2.



Equipped With One NEMA 5-15 P Plug

Full load amps and plug style may vary depending on electrical options chosen and condensing unit employed.

NOTE: When ordering please specify: Voltage, Hinging, Door Size, Options and any additional warranties. For fast order entry: Fax 1 (800) 765-8728.

Continued product development may necessitate specification changes without notice. Part No. TR35804 (revised 7/01)

Refrigeration System

A top mounted, self-contained, balanced refrigeration system using R-134a refrigerant is conveniently located behind the one piece louver assembly. It consists of an air cooled condensing unit and a high humidity gravity coil evaporator, which is suspended from the ceiling to provide an even, recirculated, cold air drop onto the stored product. Condensate from the evaporator coil and water from the ice are collected in drain gutters which run to a drain located in the floor of the cabinet. The drain is a bell trap type with a 3/4" pipe connection. The unit is equipped with a pitched floor to facilitate both drainage and cleaning. The normal operating temperature should be approximately 36° F, just right to prevent the ice from melting away too quickly. For temperature monitoring a digital thermometer is included.

Drawer Pans

Each fish file drawer is supplied with one (1) 16" wide by 18-7/8" long by 6-1/2" deep plastic pan, each pan contains a plastic perforated insert. When the ice melts, the resulting water drains through the perforated insert at the bottom of the pan into the drain port of the pan. Water is then channeled through a series of tracks to a drain located in the pitched interior bottom of the cabinet (a floor drain is required for excess water removal).

Warranties

The standard warranty includes a five year compressor warranty and a one year parts and labor warranty on all components and the cabinet. Additional warranties are available at extra cost.

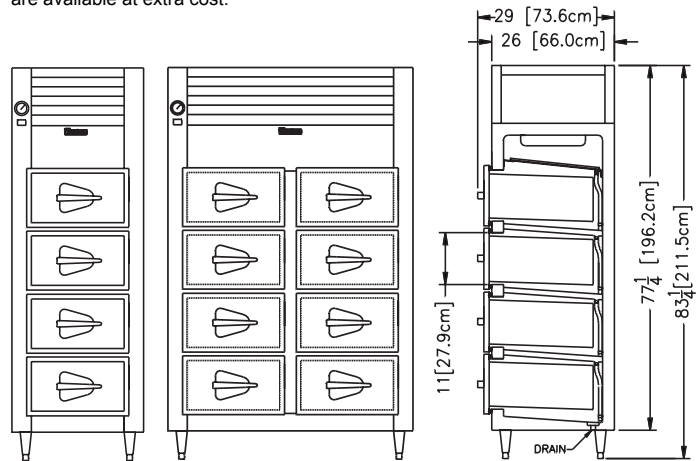

Elevation View
RFS126NUT

Elevation View
RFS226NUT

Section View
All Models

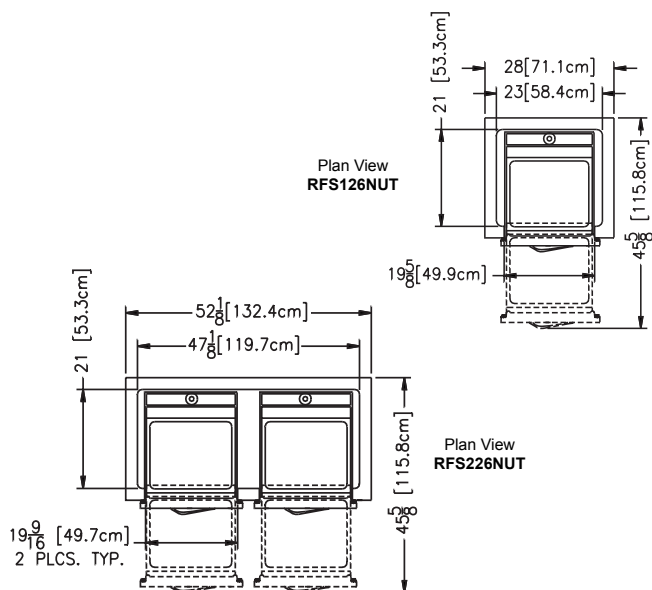

Plan View
RFS126NUT

Plan View
RFS226NUT