

3780A

PATTERN GENERATOR / ERROR DETECTOR

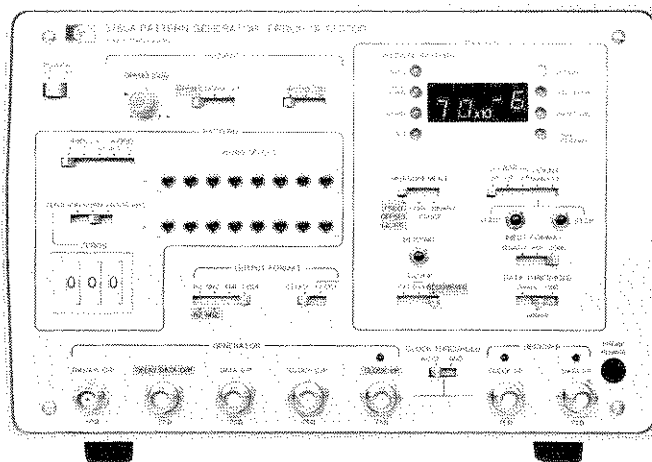

CERTIFICATION

Hewlett-Packard Company certifies that this product met its published specifications at the time of shipment from the factory. Hewlett-Packard further certifies that its calibration measurements are traceable to the United States National Bureau of Standards, to the extent allowed by the Bureau's calibration facility, and to the calibration facilities of other International Standards Organization members.

WARRANTY

This Hewlett-Packard instrument product is warranted against defects in material and workmanship for a period of one year from date of shipment. During the warranty period, Hewlett-Packard Company will, at its option, either repair or replace products which prove to be defective.

For warranty service or repair, this product must be returned to a service facility designated by HP. Buyer shall prepay shipping charges to HP and HP shall pay shipping charges to return the product to Buyer. However, Buyer shall pay all shipping charges, duties, and taxes for products returned to HP from another country.

HP warrants that its software and firmware designated by HP for use with an instrument will execute its programming instructions when properly installed on that instrument. HP does not warrant that the operation of the instrument, or software, or firmware will be uninterrupted or error free.

LIMITATION OF WARRANTY

The foregoing warranty shall not apply to defects resulting from improper or inadequate maintenance by Buyer, Buyer-supplied software or interfacing, unauthorized modification or misuse, operation outside of the environmental specifications for the product, or improper site preparation or maintenance.

NO OTHER WARRANTY IS EXPRESSED OR IMPLIED. HP SPECIFICALLY DISCLAIMS THE IMPLIED WARRANTIES OF MERCHANTABILITY AND FITNESS FOR A PARTICULAR PURPOSE.

EXCLUSIVE REMEDIES

THE REMEDIES PROVIDED HEREIN ARE BUYER'S SOLE AND EXCLUSIVE REMEDIES. HP SHALL NOT BE LIABLE FOR ANY DIRECT, INDIRECT, SPECIAL, INCIDENTAL, OR CONSEQUENTIAL DAMAGES, WHETHER BASED ON CONTRACT, TORT, OR ANY OTHER LEGAL THEORY.

ASSISTANCE

Product maintenance agreements and other customer assistance agreements are available for Hewlett-Packard products.

For any assistance, contact your nearest Hewlett-Packard Sales and Service Office. Addresses are provided at the back of this manual.



**HEWLETT
PACKARD**

OPERATING AND SERVICE MANUAL

3780A

PATTERN GENERATOR/ERROR DETECTOR

(Including Options 001, 002, 003, 099, 100, 101 and 102)

SERIAL NUMBERS

This manual applies directly to instruments with serial numbers prefixed 2020U.

With changes described in section VII this manual also applies to instruments with serial numbers prefixed 1520U to 2006U.

For additional important information about serial numbers see INSTRUMENTS COVERED BY MANUAL in section I.

© Copyright HEWLETT-PACKARD LIMITED 1981
SOUTH QUEENSFERRY, WEST LOTHIAN, SCOTLAND

MANUAL PART NUMBER 03780-90023
Microfiche Part Number 03780-90048

Printed: March 1981

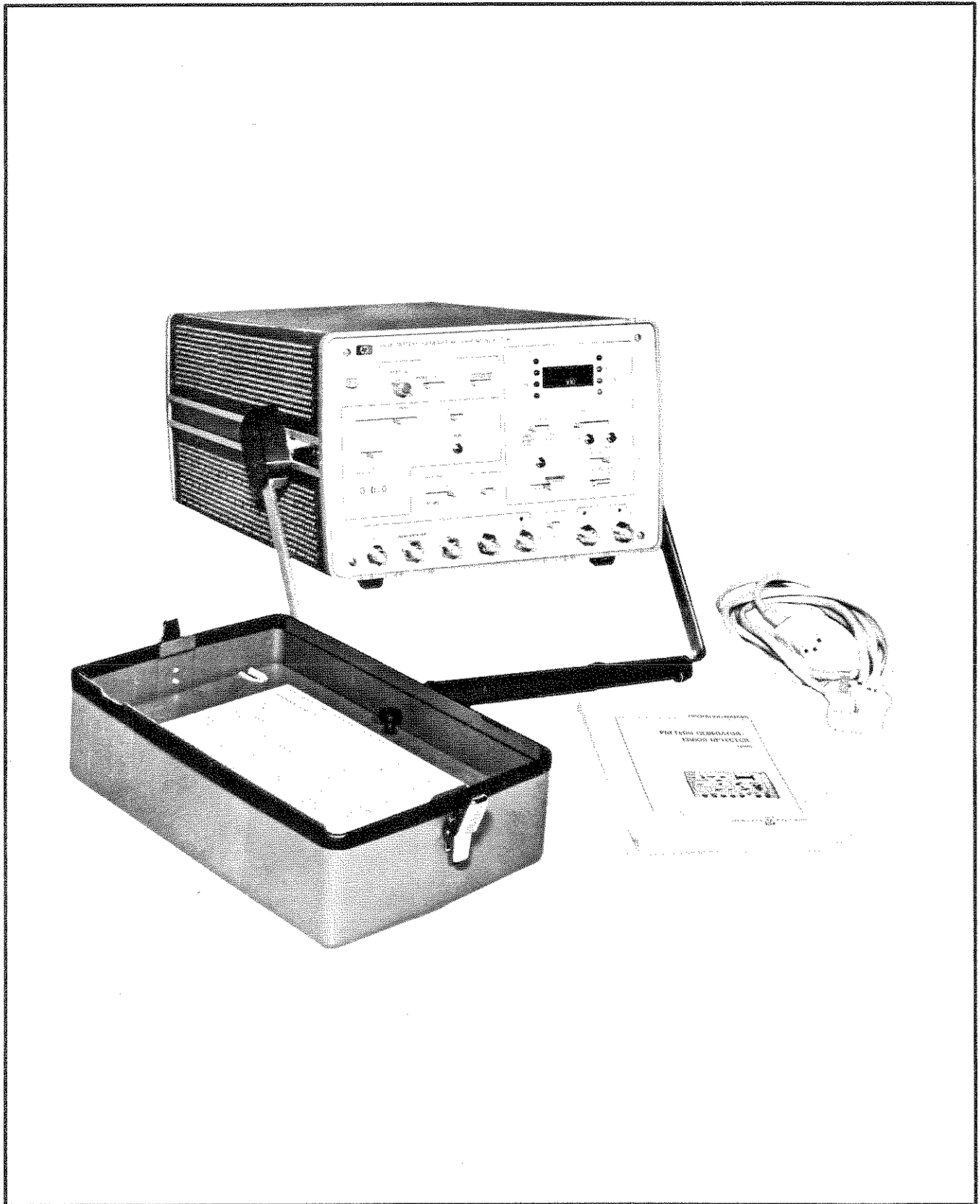

Figure 1-1 The 3780A Pattern Generator/Error Detector

SECTION I

GENERAL INFORMATION

1-1. INTRODUCTION

1-2. This Service Manual contains the information necessary to install, operate and maintain the Hewlett-Packard Model 3780A Pattern Generator/Error Detector. The instrument and accessories supplied are shown in Figure 1-1.

1-3. This manual is available in 6 x 4 inch Microfiche each containing up to 95 photo duplicates of manual pages. The Microfiche package includes the latest Manual Change Supplement and all pertinent Service Notes. The part numbers of this manual in microfiche form, as given on the title page, should be quoted when ordering.

1-4. An Operating Manual is also supplied with this instrument and should be kept with the instrument for use by the operator.

1-5. SPECIFICATIONS

1-6. The specifications of this instrument are listed in Table 1-1. These specifications are the standards against which the performance of the instrument is tested (see section IV of this manual).

1-7. SAFETY CONSIDERATIONS

1-8. This Service Manual contains information, cautions and warnings which must be followed to ensure safe operation and to maintain the instrument in a safe condition.

1-9. INSTRUMENTS COVERED BY MANUAL

1-10. The contents of this manual apply to instruments with serial numbers as specified on the title page. The in-

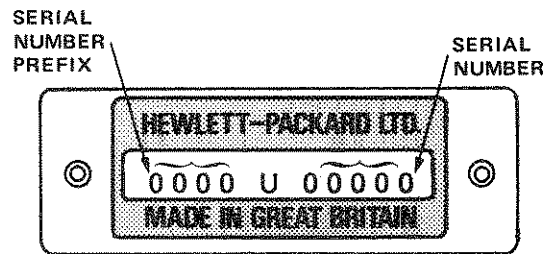

Figure 1-2 Serial Number Plate

strument serial number is given on a serial number plate as shown in Figure 1-2. This plate is located on the rear panel of the instrument. The serial number is in two parts. The first four digits and the letter are the serial prefix and the last five digits are the suffix. The whole serial number, prefix and suffix should be quoted in any correspondence regarding the instrument.

1-11. An instrument manufactured after the printing of this manual may have a serial number prefix that is not listed on the title page. This unlisted serial number prefix indicates that the instrument is different from those described in this manual. A blue Manual Changes supplement supplied with this manual provides information on how to adapt the manual for such instruments.

1-12. In addition to change information, the supplement may contain information for correcting errors in the manual. To keep the manual as accurate as possible Hewlett Packard recommend that periodic requests for the latest Manual Change supplement are made to one of the Sales and Service offices listed at the rear of this manual.

1-13. For information concerning a serial number prefix which is not listed on the title page or in the Manual Change supplement contact the nearest Hewlett Packard office.

Table 1-1 Specifications

*Notes: All transition times relate to 10 to 90% of pulse height.
All pulse widths specified at 50% of pulse height.*

PATTERN GENERATOR		Patterns	PRBS:	Maximal length $2^9 - 1$, $2^{15} - 1$, $2^{20} - 1$. Randomly selectable 9, 15, 20 bit sequences.		
Internal Clock	Frequency:	Three crystal clocks 1536, 2048 and 8448kHz.	WORD:	0000, 1000, 1010, 1100, 1111 fixed words.		
	Accuracy:	Better than ± 3 ppm at ambient.		Zero Add:	1-999 zeros, variable in unit steps, may be added once per se- quence to any pattern. Zero block occurs be- fore longest run of zeros in maximal length PRBS.	
	Stability:	Typically better than ± 12 ppm 0°C to 55°C . Typically better than ± 5 ppm/year ageing.			Error Add:	10^{-2} binary error rate may be added to any pattern (10 con- secutive errors added every 1000 clock per- iods).
	Format:	Square wave, $50 \pm 6\%$ duty cycle.				
	Jitter:	Less than (0.5% of period + 150 ps) pk-pk;				
Clock Offset	Range:	Continuously variable up to at least ± 50 ppm about installed crystal frequencies; offset can be displayed in receiver.				
External Clock	Frequency:	1kHz – 50MHz.	Data Format	Binary:	NRZ or RZ ($50 \pm 6\%$ width on internal clock).	
	Impedance:	75 ohms nominal to ground.		Ternary:	RZ AMI or coded ($50 \pm 6\%$ width on in- ternal clock).	
	Triggering:	Automatic or ground threshold switch, min pulse width (30% of period + 2 ns).		Codes:	HDB3 or HDB2 (rear panel switch).	
	Sensitivity:	Better than 500mV pk-pk.	Data Output	Impedance:	75 ohms nominal to ground.	
	Amplitude:	5V pk-pk max. limits ± 5 V.		Amplitude:	Binary $3\text{V} \pm 0.3\text{V}$ pk-pk. Ternary $4.74\text{V} \pm 0.47\text{V}$ pk-pk.	
	Indicator:	LED illuminated if clock transitions pre- sent.		DC Offset:	Binary space 0V, mark 3V. Ternary space 0V, mark $\pm 2.37\text{V}$. Ratio of +ve to -ve pulse amplitude 1.0 ± 0.05 .	
		Transition Times:		Less than 4ns.		
Clock Output	Polarity:	CLOCK or $\overline{\text{CLOCK}}$ switch.	Transition Times:	Less than 4ns.		
	Impedance:	75 ohms nominal to ground.	Overshoot:	Less than 10% of pulse amplitude.		
	Amplitude:	$3\text{V} \pm 0.3\text{V}$ pk-pk.	Protection:	Open/short circuit protected, max. vol- tage $\pm 6\text{V}$ short term.		
	DC Offset:	Space 0V, mark 3V.				
	Transition Times:	Less than 4ns.				
	Overshoot:	Less than 10% of pulse amplitude.				
	Protection:	Open/short circuit protected, max. vol- tage $\pm 6\text{V}$ short term.				

Table 1-1 Specifications (continued)

Delay Data Output	Format:	Binary only.	Data Format	Binary:	NRZ or RZ.
	Relative Delay:	6 bits advanced on main data output.		Ternary:	RZ AMI or coded.
	DC Offset:	Binary space $0V \pm 0.3V$, mark $3V \pm 0.3V$.		Codes:	HDB3 or HDB2 (rear panel switch common with generator).
	Other specifications as for main data output.				
Clock/Data Phasing	NRZ Data:	Rising edge of clock nominally in middle of data.	Clock Recovery	Frequency:	At the three internal rates of generator (selection switch common with generator).
	RZ Data:	Clock and data nominally coincide.		Mode:	Operates on any data input provided there are two or more transitions every 20 bits (data loss inhibits clock recovery circuit).
Trigger Output	Format:	Square wave with one transition per word or sequence.	External Clock	Frequency:	1kHz – 50MHz.
	Position:	Transitions nominally coincident with start of word or before first zero of longest zero block in PRBS.		Polarity:	CLOCK or $\overline{\text{CLOCK}}$ switch.
	Width:	Equal to word or sequence length, but output held at zero during zero add		Impedance:	75 ohms nominal to ground.
	Impedance:	50 ohms nominal to ground.		Triggering:	Automatic or ground threshold switch (common with generator), min pulse width (30% of period + 2ns).
	Amplitude:	1V pk-pk min.		Sensitivity:	Better than 500mV pk-pk.
	Transition Times:	Less than 5ns.		Amplitude:	5V pk-pk max, limits $\pm 5V$.
	Overshoot:	Less than 10% of pulse amplitude.		Indicator:	LED illuminated if clock transitions present.
Protection:	Open/short circuit protected, max voltage $\pm 5V$ short term.				
ERROR DETECTOR					
Data Input	Rate:	1Kb/s – 50Mb/s.	Clock/Data Phasing	Recovered Clock:	Automatic phasing.
	Impedance:	75 ohms nominal to ground.		External Clock:	Rising edge of clock should be nominally in middle of data pulse (typically 3ns internal delay of clock relative to data between inputs and sampling point).
	Triggering:	Choice of nominal threshold 200mV, 600mV, or ground; min pulse width (30% of period + 2ns).			
	Sensitivity:	Better than 500mV pk-pk.			
	Amplitude:	5V pk-pk max, limits $\pm 5V$.			
	Indicator:	LED illuminated if data transitions present.			

Table 1-1 Specifications (continued)

Patterns	PRBS and WORD:	All patterns produced by generator excluding added zeros and alternating words; receiver also recognises PRBS.	Display		
Synchronisation	Indicators:	LED indication of pattern lock for PRBS, PRBS, WORD and AIS (indicators inhibited during sync loss and code error or frequency offset measurements).	BER	Method:	Totalises errors over selected gating period and automatically scales the answer.
	Mode:	Automatic with manual override.		Gating:	10^6 , 10^8 or 10^{10} clock periods, repetitive.
	Sync Loss:	Greater than approx. 20,000 errors in 500,000 clock periods.		Format:	$X.Y \times 10^{-n}$ LED
	Manual:	Sync override via push button forcing a sync loss.		Range:	0.0×10^{-9} to 4.0×10^{-2} (binary errors). 0.0×10^{-9} to 9.9×10^{-2} (code errors over 10^{10} clock periods). 0.0×10^{-7} to 1.0×10^{-0} (code errors over 10^8 clock periods). 0.0×10^{-5} to 1.0×10^{-0} (code errors over 10^6 clock periods).
	Resync Time:	Typically less than 500 bits.		Accuracy:	Indication given if measurement result based on less than 100 errors.
Measurements	Modes:	Binary errors, code errors, frequency offset.	Display		
	BINARY ERRORS:	Closed loop bit-by-bit detection on any pattern produced by generator excluding added zeros and alternating words.	COUNT	Method:	Totalises errors over selected gating periods.
	CODE ERRORS:	Violations of coding rule detected on any pattern according to the following rules where 0 = space 1 = mark V = bipolar violation: Bipolar violations are code errors.		Gating:	Manual start/stop pushbutton switches. External control via printer output.
	AMI:	Bipolar violations are code errors.		Format:	$X.Y \times 10^{+n}$ LED with automatic round-up.
	HDB3:	01V, 10V, 11V, 0000 and 0100V are code errors.		Range:	0.0×10^1 to 9.9×10^8
	HDB3/HDB2:	Violations of violations selectable with an internal switch.	FREQ. OFFSET	Method:	Counts deviation frequency over 10^6 clock periods of internal standard crystal rate.
	HDB2/B3ZS:	1V, 000 and 010V are code errors.		Gating:	Automatic.
	B6ZS:	0V0, 1V0, 1V1, 00V1 and 000000 are code errors (see options); (000000V1 and 000000V0 are counted as single errors).		Format:	$XY \times 10^{-n}$ with automatic round-up
	FREQUENCY OFFSET:	Measurement of fractional offset of generator clock output from installed crystal rates.		Range:	Up to 25kHz deviation from nominal crystal rate.
				Accuracy:	± 1 count relative to the internal standard clocks.
			STROBING	BER & FREQ OFFSET:	Display strobed at end of gating interval; maximum refreshment rate 2Hz.
				COUNT:	Display continuously updated with round-up when measurement ends.

Table 1-1 Specifications (continued)

Flags (LED's)	Gating:	Indicates measurement in progress, will extinguish for at least 500ms between measurements.	Print Command:	TTL pulse, min. print cycle time 500 ms.
	Sync Loss:	Indicates local pattern reference has lost sync; display blanks and measurement is terminated (BER) or halted (COUNT); flag remains lit for at least 500ms (BER) or held (COUNT) until measurement is terminated.	Recorder Output Format:	Current source with 500ms minimum response.
	Overflow:	Indicates internal error or frequency count $\geq 10^9$; display blanks and measurement is terminated (BER) or halted (COUNT); flag remains lit for at least 500ms (BER) or held (COUNT) until measurement is terminated.	Impedance:	Greater than 50K ohms.
	<100 Errors:	Indicates less than 100 errors counted during last error measurement (inhibited during frequency offset measurements).	Range:	1mA variation over 16 levels into 10K ohms max.
Printer Output (rear panel)	Format:	8421 BCD 10 columns BER F * X * Y * 10 - N COUNT F * X * Y * 10 + N	BER:	Thirteen level signal
	Flags:	F = V for <100 errors F = 1 for overflow F = 2 for sync loss F = 3 for clock loss F = 4 for data loss F = A for AIS	LEVELS	BER
	Print Modes:	BER - print command given on termination of measurement. COUNT MAN - print command given on STOP command from front panel. COUNT EXT - print command given on STOP command from printer.	FSD	15 10^{-8} 14 10^{-7} 13 10^{-6} 12 10^{-5} 11 10^{-4} 10 10^{-3} 9 10^{-2} 8 10^{-1} 7 10^{-0} 6 = <math>10^0< math=""> 4 Sync Loss 2 AIS 0 Signal Loss</math>10^0<>
			COUNT:	Five level signal
			LEVELS	REFERENCE
			FSD	15 Signal no errors 7 Signal plus errors 4 Sync loss 2 AIS 0 Signal Loss
				} except AIS
			<i>Note: when using recovered clock, signal loss = data loss; when using external clock, signal loss = clock loss.</i>	
			Calibration:	Two rear panel push buttons giving FSD and Zero. Internal adjustment of range 1mA \pm 0.2mA and centering 0mA to 0.5mA.
			Error Output (rear panel)	Format:
				One pulse per error (inhibited during sync loss).
				Impedance:
				50 ohms nominal to ground.
				Amplitude:
				1V pk-pk min.
				Transition Times:
				Less than 5ns.
				Overshoot:
				Less than 10% of pulse amplitude.

Table 1-1 Specifications (continued)

	Protection:	Open/short circuit protected, max. voltage $\pm 5V$ short term	Dimensions	195 x 335 x 475mm (H x W x L). 7 3/4 x 13 3/16 x 18 5/8 in
			Weight	12.5kg 27 1/2lb net.
Trigger Output (rear panel)	Format:	One pulse per sequence (PRBS) only.	Environment	Operating temperature range 0 to +55°C. Storage temperature range -40 to +75°C.
	Position:	Near the start of the longest zero block in PRBS.		
	Width:	Nominally one clock period.	Accessories	hp 15508A: 75 ohms unbalanced to 110 ohms balanced impedance passive converters having frequency range 1 - 10MHz.
	Impedance:	50 ohms nominal to ground.		
	Amplitude:	1V pk-pk min.	Notes	All transition times relate to 10% - 90% of pulse height. All pulse widths specified at 50% of pulse height.
	Transition Times:	Less than 5ns.		
	Overshoot:	Less than 10% of pulse amplitude.		
	Protection:	Open/short circuit protected, max voltage $\pm 5V$ short term.	OPTIONS	
Clock Output (rear panel)	Format:	Detector clock available as a monitor.	001	All words replaced by 16 bit front panel programmable word. This can also provide two 8 bit words alternated by an external signal applied via the rear panel. Changeover is synchronous with end of words. Zero add then operates on individual 8 bit words, and trigger output is 8 bits wide. External input sensitivity: 250mV pk-pk squarewave DC to 100kHz. 0.5V pk-pk sine or triangular wave, 200Hz - 100kHz Max input voltage: 15V rms. Impedance: nominally 1000 ohms
	Width:	Nominal 50% duty cycle for recovered clock.		
	Impedance:	50 ohms nominal to ground.		
	Amplitude:	1V pk-pk min.		
	Transition Times:	Less than 5ns.		
	Overshoot:	Less than 10% of pulse amplitude.		
	Protection:	Open/short circuit protected, max. voltage $\pm 5V$ short term.		
GENERAL				
Power Supply	115V	+10% -22%	or 230V	+10% -18%
	AC 48 - 66Hz max. consumption approx 110VA			
Probe Power	External fused supplies of nominally +5V, 200mA and -5V, 200mA for HP logic probes (rear panel).			002 003 099 100
Packaging	Modified hp 1700 series oscilloscope case with fan; clip-on front cover with space for power cable, accessories, and instruction manual.			Siemens 1.6mm connectors replace all external 75 ohms BNC connectors. Combination of options 001 and 002. Clock frequency offset generation deleted. Internal clock frequencies of 2048, 8448 and 34368kHz. When the 3780A is used at f3 = 34.368 Mb/s with a ternary coded output & input format, the following parameters apply.
Connectors	All signal connectors are BNC (except options 002, 003). Printer output via 50 pin Amphenol connector. Recorder output via two binding posts.			Data Output Impedance: Nominal 75Ω to ground. Amplitude: $\pm 1V \pm 0.1V$. Zero Level: 0V $\pm 0.1V$. Transition Times: <4ns. Overshoot: <10% pulse Amplitude.

Data Input

Rate: Nominal 34.368Mb/s.
 Impedance: Nominal 75Ω to ground.
 Equalisation: Automatic \sqrt{f} equalisation for cable losses up to -12dB at $fc/2$ from a 1V pk source.
 Format: Ternary coded HDB2 or HDB3.
 Amplitude: 3V pk max.
 Indicator: LED illuminated if data transitions present.

101

Internal clock frequencies of 1544, 6312 and 44736kHz HDB3/HDB2 codec replaced by B6ZS/B3ZS codec.
 When the 3780A is used at $f_3 = 44.736\text{ Mb/s}$ with a ternary coded O/P & I/P format, the following parameters apply.

Data Output

Impedance: Nominally 75Ω unbalanced.
 Shape: Conforms with CCITT pulse mask for co-axial pair interface at 44.736 Mb/s (CCITT recommendation G703.4).
 Amplitude: Nominally 0.6V pk.

Data Input

Rate: Nominally 44.736Mb/s.
 Impedance: Nominally 75Ω unbalanced.
 Equalisation: Automatic \sqrt{f} equalisation for cable losses up to 12dB at $fc/2$ from a 0.909V pk source.
 Format: Ternary coded B6ZS or B3ZS.
 Amplitude: 3V pk max.
 Indicator: LED illuminated if data transmission present.

102

Internal clock frequencies of 1544, 6312 and 3152kHz HDB3/HDB2 codec replaced by B6ZS/B3ZS codec.

1-14. DEFINITION OF TERMS

1-15. The following are brief definitions of terms which relate to the functions of the instrument and are commonly used in this manual:

1-16. AMI

Alternate Mark Inversion is a form of Ternary data (described below) in which data "Marks", normally representing "ones", are alternately positive and negative going. The advantages of this basic code are that the average dc potential on the line is zero, and that this code can be used to detect if one data bit is missing as two consecutive bits would then have the same polarity.

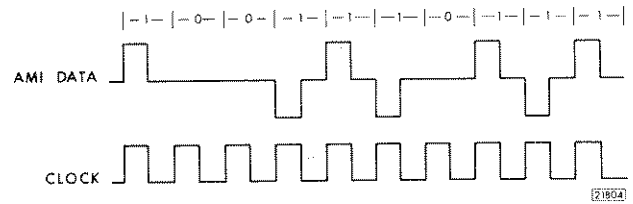

Figure 1-3 AMI Data/Clock

1-17. BER

Bit Error Rate is the rate at which errors occur relative to the clock count. If 10 errors occur in 1000 clock periods the BER is 1.0×10^{-2} .

1-18. Binary Data

Data ones and zeros are represented by a two level signal. See RZ and NRZ.

1-19. Bipolar Violations

Violations of the coding rules in which two consecutive bits have the same polarity. The data bit which violates the coding rules is normally designated V.

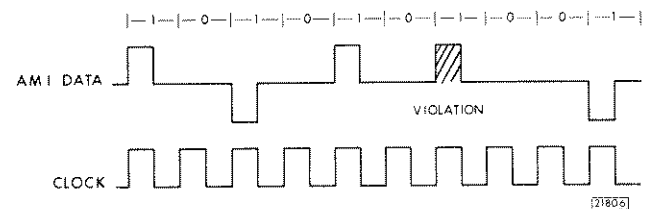

Figure 1-4 Bipolar Violation

1-20. Codes

Refinements of the AMI code in which long sequences of zeros are eliminated by substituting a fixed pattern for the sequence of zeros. The substitution allows the clock signal to be more easily recovered from the data when long runs of zeros occur. The codes referred to in this manual are as follows:

HDB2/B3ZS High Density Binary 2 (HDB2)/Binary 3 zeros substitution (B3ZS) are two similar codes in which a pattern is substituted for each block of three consecutive zeros in the data stream.

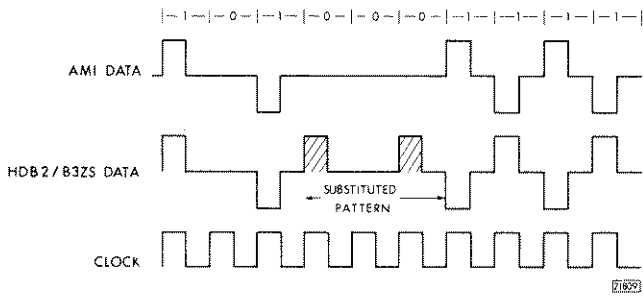

Figure 1-5 HDB2 Data

HDB3 High Density Binary 3 substitution and **B6ZS** Binary 6 Zeros substitution are codes with substitutions for 4 and 6 consecutive Zeros respectively.

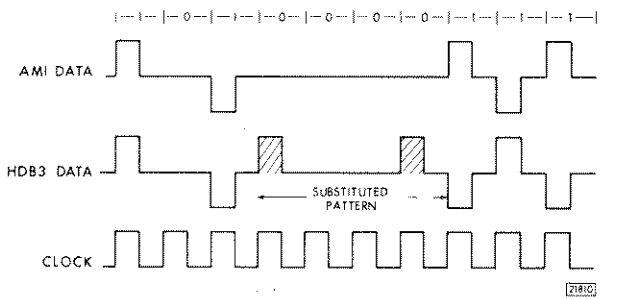

Figure 1-6 HDB3 Data

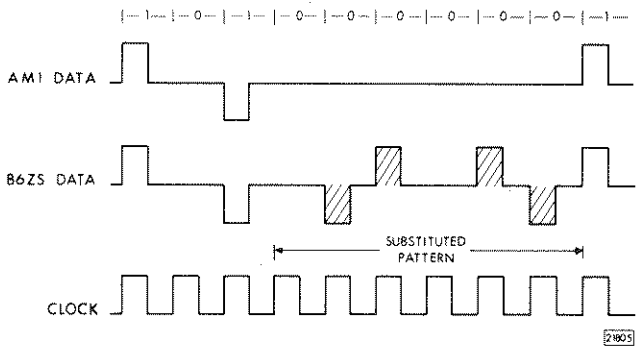

Figure 1-7 B6ZS Data

1-20A Violation of Violation HDB2/HDB3 only

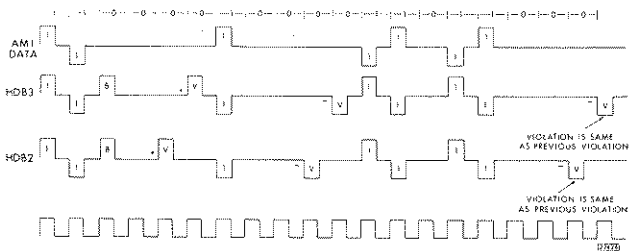

Figure 1-8 AMI Data

Instruments fitted with S1 on the 03780-60134 Board have an additional mode of operation. In the VOCAB position a code error is recorded when a violation (two successive bits of the same polarity) of the coding rule occurs. In the VIOLS position, a code error is only recorded when there are two successive violations of the same polarity.

With AMI code errors, any violation of the AMI coding rule is recorded as code error, irrespective of the position of the VOCAB/VIOLS switch.

1-21. Delay Data

As applied to this instrument delay data is data which is delayed by 6 bits less than a full sequence ie it is 6 bits in advance of the normal data.

1-22. Error Add

Binary data bits changed to produce an error without increasing the sequence length. The errors introduced take the form of the complement of 10 data bits in each 1000 bits.

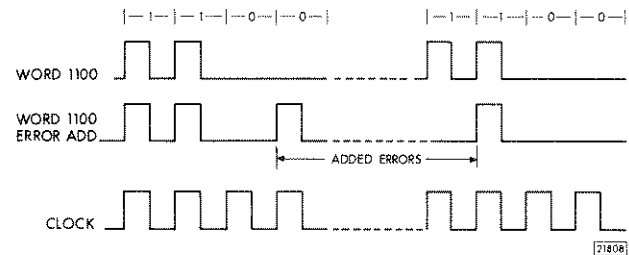

Figure 1-9 Error Add

1-23. NRZ

Non Return to Zero data remains at the 'one' level for the whole clock period. The data level is continuous between consecutive data 'ones'.

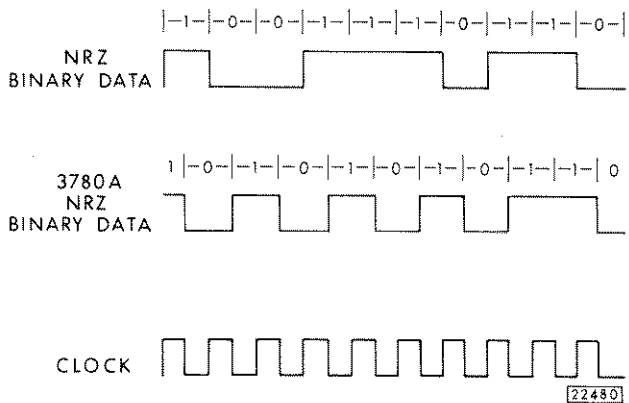

Figure 1-10 NRZ Data

In theory NRZ data rising and trailing edges are in phase with the clock edges, but the 3780A clock edges coincide with the centre of the valid NRZ data.

1-24. Offset Clock Frequency Generation

The generation of clock frequencies which may be varied about the normal fixed frequencies F1, F2 or F3. F1, F2 and F3 are the frequencies of the crystal oscillators in the 3780A.

1-25. Offset Clock Frequency Measurement

The measurement of the fractional frequency difference between the normal and offset frequencies ie ΔF offset/ F normal where F normal is the frequency F1, F2 or F3 generated in the Pattern Generator section of the instrument making the measurement.

1-26. PRBS

Pseudo Random Binary Sequence. A repetitive sequence $2^n - 1$ bits long generated by an n stage shift register. For example a 9 stage shift register produces a sequence $2^9 - 1$ or 511 bits long.

1-27. Recovered Clock

The receiver clock signal recovered from data.

1-28. RZ

Return to Zero data is at the 'One' level for the duration of the clock mark and returns to zero for the duration of the clock space.

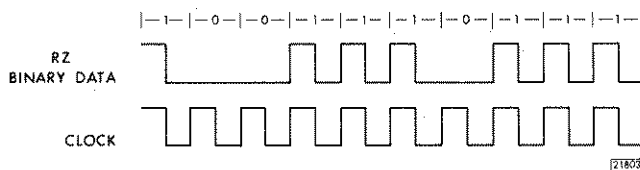

Figure 1-11 RZ Data

1-29. Synchronisation

As used in the 3780A synchronisation is the generation in the Error Detector of the particular sequence being received. The sequence generated in the Error Detector must be in phase with the received sequence for correct synchronisation.

1-30. Ternary Data

"One" and "Zero" are represented by a three level signal. Ternary data is a general term which includes AMI and the codes described in this section.

1-31. Word

A repetitive fixed sequence.

1-32. Zero Add

Zeros added to each sequence which increase the sequence length.

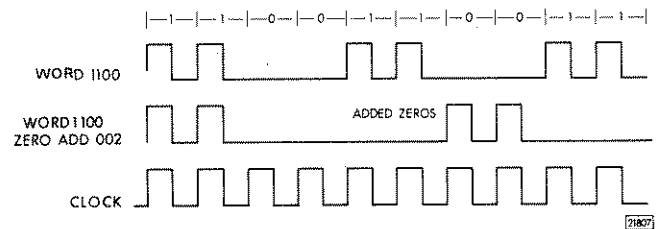

Figure 1-12 Zero Add

1-33. DESCRIPTION

1-34. The 3780A Pattern Generator-Error Detector is a complete error measuring system contained in one portable unit. The instrument measures Binary and Code errors on digital transmission equipment operating at bit rates in the range 1Kb/s - 50Mb/s. Frequency Offset measurements can also be performed at the frequencies installed in the generator.

1-35. Binary Errors. The pattern generator transmits a digital test pattern into the system to be tested. Simultaneously, the error detector compares the output of the system under test bit by bit with an internally generated pattern. Detected errors can be counted over a chosen gating period and displayed as bit error rate (BER) or total error count (COUNT) on an LED display.

1-36. Code Errors. The error detector can be used to monitor interface or line coded information for code errors. These are detected during the decoding process and are counted and displayed in the same way as binary errors. The information need not be a pattern produced by the generator.

1-37. Frequency Offset. The clock frequency in the pattern generator may be offset and measured in the error detector (receiver). The offset is displayed as a fraction of the nominal crystal centre frequency. The offset of external clock signals applied to the generator can be measured if the frequency is within 25kHz of an installed crystal frequency.

1-38. Frequency Control. The generator and receiver may be operated from external clocks in the range 1kHz to 50MHz. The generator has three internal crystal sources in the range 1.5 – 50MHz which may be selected from a number of options. The receiver clock can be recovered from incoming patterns at the frequencies installed in the generator. The generator internal clocks can be offset by up to at least ±50ppm (except Option 099).

1-39. Pattern Selection. Three maximal length pseudo random binary sequences (PRBS) of length 511, 32767 and 1048575 bits and five four bit repetitive word patterns are produced by the generator. The PRBS generator may also be used to generate random repetitive word patterns of length 9, 15 or 20 bits.

1-40. Option 001 provides a front panel programmable, 16 bit word in place of the five four-bit and random repetitive word patterns. This can also provide two 8 bit words alternated by an external signal applied via the rear panel.

1-41. Up to 999 zeros can be added once per sequence to all of the selectable patterns.

1-42. When the PRBS/WORD switch of the receiving instrument is set to one of the PRBS positions, or when the internal SYSTEMATIC ERROR DETECTION switch A37 S2 is set to OFF, the error detector automatically recognises and reproduces a synchronous error free version of any PRBS or WORD pattern produced by the generator. This includes PRBS but excludes any pattern containing added zeros or alternating words (Options 001 or 003).

Instruments are supplied with the internal SYSTEMATIC ERROR DETECTION switch, A37 S2, set to the ON position. In this mode the reference WORD of the receiving instrument can be preset to one of the fixed 4 bit words, or with Options 001 or 003 to the 16 bit word. This is achieved by setting the PRBS/WORD switch of the receiving instrument to the appropriate 4 bit word, or with Options 001 or 003 by setting the PRBS/WORD switch to 16 and selecting the appropriate word with the WORD SELECT switches. Systematic errors on the 4 or 16 bit words will then result in sync loss at the receiving instrument.

A typical example of the use of systematic error detection in an end-to-end measurement is given below:

If the transmitted word 1100 is repeatedly received as 1000 as the result of a systematic fault, then the following results will be obtained with the receiving instrument.

PRBS/WORD Switch Setting (receiving instrument)	RESULT	
9, 15 or 20	NO ERRORS	WORD
1000	NO ERRORS	WORD
1100	ERRORS	SYNC LOSS

An indication of receive pattern lock is given by LED lamps. A manual override on the automatic sync is provided which forces a sync loss; when released the instrument reverts to automatic synchronisation.

1-43. Data and Clock Format. The generator test pattern may be produced in binary RZ or NRZ, or ternary, HDB3 or HDB2 formats. When operating in binary format a second binary output is available which is 6 bits advanced on the main data output. The receiver data input format selection is independent of the generator controls.

1-44. CLOCK or $\overline{\text{CLOCK}}$ may be selected independently on generator output and receiver input.

1-45. A choice of trigger threshold is provided on clock and data inputs allowing continuous or burst mode operation. Indication of signal triggering is given by LED lamps.

1-46. Error Counter Control and Display. Control of error counter timebase may be internal over 10^6 , 10^8 or 10^{10} clock periods, manual via start/stop push buttons or external via the printer output connector. Internal error counts are displayed as a scaled BER reading in the form X.Y x 10^{-n} . Error counts over a manually or externally controlled timebase are displayed as a scaled COUNT reading in the form X.Y x 10^{+n} . Frequency offset is displayed as a fraction of the nominal centre frequency in the form XY x 10^{-n} where n = 6 usually. The display uses seven segment LED characters.

1-47. Flags. Indications of measurement gating, sync loss and count overflow are provided by LED lamps. An indication is also given if the last measurement result is based on less than 100 errors.

1-48. Self Check (Error Add). A fixed binary error rate of 10^{-2} may be injected into the test pattern in order to check the error detector functions. ERROR ADD and ZERO ADD cannot be used simultaneously.

1-49. Trigger Outputs. A trigger output, giving one transition per sequence, is available from a front panel socket on the generator. The output is modified during zero add to allow examination of the zero block or the pattern immediately following it on an oscilloscope.

1-50. The receiver section also provides a trigger output, (for PRBS only) giving one pulse per sequence, from a rear panel socket.

1-51. Error Detector Outputs. In addition to receiver trigger and clock outputs, there are three outputs which can be used to evaluate error distribution. These are an error output giving one pulse per error, a BCD printer output and a pen recorder output.

1-52. OPTIONS

1-53. Option 001 provides front panel programmable 16 bit or two 8 bit words as described in Section 3, Para. 3-15.

1-54. Option 002 provides small Siemens connectors on all external 75 ohms interfaces in place of BNC connectors.

1-55. Option 003 is a combination of options 001 and 002.

1-56. Option 099 deletes frequency offset generation.

1-57. Options 100-102 provide different crystal frequencies to those fitted in the standard instrument. The frequencies available are listed in Table 1-2.

Table 1-2 Internal Crystal Clock Frequencies

STANDARD	2048, 8448 and 1536kHz
OPTION 100	2048, 8448 and 34368kHz
OPTION 101	1544, 6312 and 44736kHz
OPTION 102	1544, 6312 and 3152kHz

In the case of options 101 and 102 the HDB3/HDB2 codec is replaced by a B6ZS/B3ZS codec.

1-58. ACCESSORIES SUPPLIED

1-59. Figure 1-1 shows the HP model 3780A and the accessories supplied, these are as follows:-

- Operating Manual 03780-90011
- Operating and Service Manual 03780-90008
- Power Cable see paragraph 2-12 and Figure 2-2
- Extender Board (fitted 03780-60021 behind board position 39 and fixed to the instrument sideframe with 3 screws).
- Storage Cover 03770-70096
- Printer Output connector 1251-0086

1-60. ACCESSORIES AVAILABLE

1-61. The following accessory is available for use with the 3780A and can be purchased through your nearest HP Sales and Service Office (see list at rear of manual).

- HP Model 15508A. . . 75Ω Unbalanced to 110Ω Balanced Converter with a frequency range from 1 to 10MHz.

1-62. RECOMMENDED TEST EQUIPMENT

1-63. Equipment required to maintain the model 3780A is listed in Table 1-3. Other equipment may be substituted if it meets or exceeds the critical specifications listed in the table. The section of the manual in which each item of test equipment is given in the USE column where P = Performance tests, A = Adjustments and T = Troubleshooting.

Table 1-3 Recommended Test Equipment

Instrument	Critical Specification	Recommended Model	Use
Electronic Counter	dc - 50MHz The time base must use a high stability crystal oscillator $< 5 \times 10^{-10}$ /day $< 1 \times 10^{-11}$ /1 sec rms (short term) 7×10^{-9} 0° to 50°C. Must be capable of making ratio measurements as well as frequency and period. The counter must also have prescaler facilities up to 10MHz input frequencies.	hp 5327A OP011	PAT
Oscilloscope 10:1 Probe	Sensitivity 5mV/cm, dual trace. dc - 75MHz, Impedance 1MΩ and 50Ω.	hp 180A/1808A/1820A/21A hp 1004B	PAT
Sampling Oscilloscope	Dual trace, dc - 1GHz rise time <350ps.	hp 180A/1810A	PAT

Table 1-3 Recommended Test Equipment (continued)

Instrument	Critical Specification	Recommended Model	Use
HF Probe	dc -- 500MHz.	hp 1120A	PAT
10:1 Divider	1M Ω input impedance.	hp 10241A	PAT
BNC Adaptor		hp 1250-0052	PA
VHF Oscillator	10MHz -- 50MHz, 0 -- +10dBm into 50 Ω , with a variable output control.	hp 8654A	PAT
Test Oscillator	1kHz -- 10MHz, 500mV pk-pk into 75 Ω or greater.	hp 651B Option 02	PAT
Function Generator	0.0001Hz -- 1MHz sine and square wave, with $\pm 5V$ dc offset control.	hp 3310A	P
Pulse Generator	Rise times less than 2ns. Min period less than 20ns. Min pulse width less than 8ns. Must be able to be externally triggered. Must have complement output control. Must give 1.6V pk-pk into 50 Ω .	hp 8008A	P
Digital Voltmeter	1mV Resolution and isolated input terminals.	hp 34740A/34702A	PAT
Attenuator (Qty 1)	dc -- 50MHz, 0 -- 25dB presettable, 75 Ω .	hp 3750A	PA
Attenuator (Qty 2)	50 Ω 20dB coaxial fixed rise time <2.5nS.*	hp 8691B	PA
Power Supply	0 -- 15V, 0.75A dual dc power supply.	hp 6205B	PAT
Resistor	3 off, 75 Ω 1% 1/8W	hp 0757-0598	PA
Resistor	1 off, 511 Ω 1% 1/8W	hp 0757-0416	PA
Resistor	1 off, 1.5K Ω 1% 1/8W	hp 0757-0427	PA
Resistor	1 off, 10K Ω 1% 1/8W	hp 0757-0442	P
Cables STD	4 off, 75 Ω BNC	hp 15525A	PAT
Cables STD	2 off, 50 Ω BNC	hp 10501A	PAT
75/50 Ω Matching Pad	3 off, dc -- 200MHz	hp 85428B Rohde & Schwarz type DAF BN 18084 + Adaptors FHS 40901/50 & FHD 40901/75 Greenpar type 507-4718-707	PA
Digital Recorder		hp 5055A	P
VHF Oscillator		hp 3200A	A
Logic Pulser		hp 10526T	T
TTL Logic Probe		hp 10525T	T
ECL Logic Probe		hp 10525E	T

*Note: When using 8691A 20dB coaxial attenuator (50 Ω) $V_o = \frac{V_i}{10}$

Table 1-4 Recommended Adaptors for Standard Instrument

Item	Minimum Specification	Recommended Type
Adaptor BNC female 50Ω to GR 874 1 off		Greenpar GE 500/508
Adaptor N – Male 50Ω to BNC female 50Ω 1 off		hp 1250-0082
Adaptor BNC 'T' 75Ω 2 off		Greenpar GE 375531
Adaptor BNC 'T' 50Ω 2 off		hp 1250-0781
Adaptor Banana to BNC female		hp 10111A
Adaptor BNC Male 75Ω to BNC Male 75Ω		hp 1250-1288
75Ω Load BNC		hp 15522A
50Ω Load BNC		hp 11593A

Table 1-5 Recommended Adaptors for Option 002 Instrument

Note:- The adaptors listed here are in addition to the ones listed for the standard instrument.

Item	Minimum Specification	Recommended Type
Adaptor 1.6/5.6mm male 75Ω to BNC female 75Ω 3 off		Spinner BN 88 84

SECTION II INSTALLATION

2-1. INTRODUCTION

2-2. This section provides installation instructions for the Model 3780A and its accessories. This section also includes information about initial inspection, damage claims, preparation for use, packaging, storage and shipment.

2-3. INITIAL INSPECTION

2-4. Inspect the shipping container for damage. If the shipping container or cushioning material is damaged, it should be kept until the contents of the shipment have been checked for completeness and the instrument has been checked mechanically and electrically. The contents of the shipment should be as shown in Figure 1-1 and listed in Paragraph 1-59. Procedures for checking the electrical operation are given in Section IV of this manual. If the contents are incomplete, if there is mechanical damage or defect, or if the instrument performance fails to meet specification, notify the nearest Hewlett-Packard Sales and Service Office as listed at the rear of this manual. If the shipping container is damaged, or the cushioning material shows signs of stress, notify the carrier as well as the Hewlett-Packard Office. Keep the shipping materials for the carriers inspection. The Hewlett-Packard Office will arrange for repair or replacement at HP option without waiting for a claim settlement.

2-5. PREPARATION FOR USE

2-6. Power Requirements

2-7. The model 3780A requires a power source of 115V ac (+10% to -22%) or 230V ac (+10% to -18%), 48 to 66Hz single phase. The maximum power consumption is approximately 110VA.

WARNING

If the instrument is energised via an autotransformer, ensure that the common terminal is connected to the earthed pole of the power source.

2-8. Line Voltage Selection

CAUTION

BEFORE SWITCHING ON THIS INSTRUMENT ensure that the voltage selector is set to the voltage of the power source.

2-9. The location of the power input connector, power line fuse and voltage selector switch are shown in Figure 2-1. Remove the power line fuse. Set the voltage selector switch to 115V or 230V as appropriate. Ensure that the correct fuse is fitted for the voltage selected as given in Table 2-1. Replace the fuse.

CAUTION

The replacement of blown fuses should not be performed without reference to the power supply troubleshooting procedure Page 8-55. Power supply assembly damage can occur if the correct procedure is not carried out.

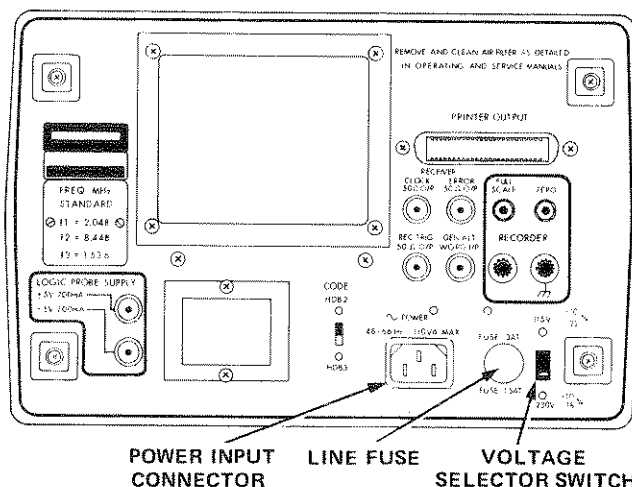

Figure 2-1 Power Input, Fuse and Voltage Selector

2-10. Fuses

2-11. The power line fuse depends on the supply voltage selected. Table 2-1 provides the ratings and Hewlett Packard stock numbers of suitable fuses.

Table 2-1 Fuse Ratings

Voltage Selector	Fuse Rating	HP Stock Number
115V	3A Timed 250V	2110-0381
230V	1.5A Timed 250V	2110-0304

2-12. Power Cable

2-13. In accordance with international safety standards this instrument is equipped with a three wire power cable. When connected to an appropriate power receptacle, this cable grounds the instrument cabinet. The type of power cable shipped with each instrument depends on the country of destination. Figure 2-2 illustrates the standard power receptacles that are commonly used. The HP stock number

					
CABLE STOCK NUMBER	8120-2104	8120-0696	8120-1692	8120-1703	8120-1521

Figure 2-2 Power Receptacles

shown with each receptacle is the stock number of a power cable equipped with the appropriate mating plug for that receptacle. If the appropriate power cable is not included with the instrument, notify the nearest hp Sales and Service Office and a replacement will be provided.

2-14. The colour codes used in each power cable are:

Table 2-2 Power Cable Colour Codes

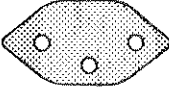
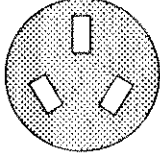
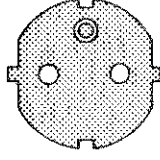
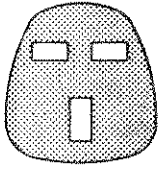
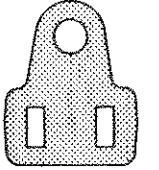
Line	Brown
Neutral	Blue
Ground	Green/Yellow

WARNING

BEFORE SWITCHING ON THIS INSTRUMENT, the protective earth terminal of this instrument must be connected to the protective conductor of the (mains) power cable. The mains plug shall only be inserted in a socket outlet provided with a protective earth contact. The protective action must not be negated by the use of an extension power cable without a protective conductor (grounding).

2-15. STORAGE AND SHIPMENT

2-16. Temperature Range

2-17. The instrument may be stored or shipped in temperatures within the limits -40°C to $+75^{\circ}\text{C}$. It is advisable to protect the instrument from extreme temperature variation which can cause excessive condensation.

2-18. Packaging

2-19. Original Packaging. Containers and materials identical to those used in factory packaging are available through Hewlett-Packard Offices. If the instrument is being returned to Hewlett-Packard for servicing, attach a tag indicating the type of service required, return address, model number and full serial number. Mark the containers FRAGILE to ensure careful handling. In any correspondence, refer to the instrument by model number and full serial number.

2-20. Other Packaging. The following general instructions should be used for repacking with commercially available materials:

- (a) Wrap the instrument in heavy paper or plastic. If shipping to Hewlett-Packard for servicing, attach a tag indicating the type of service required, return address, model number and full serial number.
- (b) Use a strong shipping container eg. a double walled carton of 350 pound tested material.
- (c) Protect the control panel with cardboard and insert a three to four inch layer of shock absorbing material between all surfaces of the instrument and the sides of the container.
- (d) Seal the shipping container securely.
- (e) Mark the shipping container FRAGILE to ensure careful handling.
- (f) In any correspondence, refer to the instrument by model number and full serial number.

2-21. Mating Connectors

2-22. The connectors which mate with the front and rear panel BNC connectors vary depending on the diameter of the cable used. Some examples of suitable connectors are given in Table 2-2.

2-23. Interconnecting Cables

2-24. A selection of 50 and 75 ohm interconnecting cables are available from Hewlett-Packard Sales and Service Offices. A cable, stock number 562A-16C, suitable for connecting the model 3780A printer output to an hp model 5055A, 5050B, or 5150A printer is also available.

Table 2-3 Mating Connectors

Front/Rear Panel Connector	Impedance/ Type	Cable		Mating Connector HP Stock Number
		Typical O/D Inches	HP Stock Number	
GENERATOR: Clock I/P Clock O/P Data O/P Delay Data O/P RECEIVER: Clock I/P Data I/P	75Ω BNC	0.269 0.153	8120-1289 8120-0049	1250-1448 1250-0629
GENERATOR: Trigger O/P RECEIVER: Rear Panel: Clock O/P Error O/P Rec Trig O/P	50Ω BNC	0.199	8120-0017	1250-0533
PRINTER O/P	50 Pin Amphenol	For cable with connectors see paragraph 2-23.		1251-0086 Amphenol Type 57-30500-375

**SECTION III
OPERATION**

3-1. INTRODUCTION

3-2. This section explains the functions of the controls, connectors and indicators of the hp model 3780A. It describes operator maintenance for cleaning the air filter. An operators check procedure on the main functions of the instrument and basic operating procedures are also provided.

3-3. Operating instructions are also provided in a separate Operating Manual stock number C3780-90011. The Operating Manual is designed to be stored in the instrument storage cover. In addition to the Operating Manual, basic operating instructions are provided on a card, stock number 7120-4982, which is fixed to the lid of the storage cover.

Note: The following items affect the operation of the 3780A Pattern Generator/Error Detector.

(a) *Clock Recovery/2²⁰ - 1 PRBS. The 2²⁰ - 1 PRBS with NRZ output format does not meet the criterion of two or more transitions in every 20 bits, required for clock recovery.*

(b) *Avoiding Jitter on Transmitted Frequency. The MEASUREMENT switch of a sending instrument should not be set to FREQUENCY OFFSET*

Δf/f as this receiver setting can cause jitter on the transmitted clock.

(c) *All internal switches are pre-set and if moved, for any performance test, should be reset to the NORMAL OPERATING CONDITION (table 3-1A).*

Table 3-1A Internal Switch Settings

Switch	Operating Condition
A37S1 (TEST NORMAL)	NORM
A37S2 (SYSTEMATIC ERROR DETECTION)*	ON
A34S1 (VIOLATION OF VIOLATIONS)**	VOCAB
A37S3 (MANUAL SYNC LOSS)†	OFF
A13S1 & A13S2 (LINE BUILD OUT/EQUALISER) ††	ON

* Instruments before S/N 1620U-00211 do not have this facility unless fitted with board 03780-60137 or 03780-60637.

** Instruments before S/N 1726U-00391 do not have this facility unless fitted with board 03780-60134.

† Instruments before S/N 1901U-00890 do not have this facility.

†† Instruments before S/N 1915U-00976 do not have this facility unless fitted with board 03780-60613.

3-4. PANEL FEATURES

3-5. The front and rear panel controls, connectors and indicators are described in the following functional groups:

Generator frequency controls

pattern controls
format controls and output connectors

Receiver input controls and connectors
synchronisation and synchronisation indicators
measurement controls
display and flag indicators
outputs

Power controls and connectors

Option controls and connectors

3-6. GENERATOR FREQUENCY CONTROLS

Determine generator clock frequency.

- (1) The CLOCK SELECTION switch selects the generator clock source:
In the EXT position the generator is clocked with an external input in the range 0.5 to 5V pk-pk applied to the CLOCK I/P connector (4). In the NORM position the generator is clocked with one of the crystal clock frequencies selected with the frequency switch (2). In the OFFSET position the generator is clocked with a frequency offset from that selected with the FREQUENCY switch (2) by an amount up to ± 50 ppm. The amount of offset is selected with the OFFSET (Δf) control (3).

- (2) The FREQUENCY switch selects one of three internal crystal oscillators as a clock source for the generator section. This switch also selects the appropriate clock recovery circuit in the receiver when the RECOVERED position of the receiver CLOCK switch (23) is selected. The frequencies indicated by f_1 , f_2 and f_3 are listed on the rear panel of the instrument. The frequencies available are given in Table 3-1.

Table 3-1 Options/Frequencies

	f_1 kHz	f_2 kHz	f_3 kHz
Standard	2048	8448	1536
Option 100	2048	8448	34368
Option 101	1544	6312	44736
Option 102	1544	6312	3152

- (3) The OFFSET (Δf) control can be used to vary the generator clocking frequency from the fixed values f_1 , f_2 or f_3 , selected with the FREQUENCY switch (2), by up to ± 50 ppm. This control is only operative when the CLOCK SELECTION switch (1) is in the OFFSET position.
- (4) The CLOCK I/P connector accepts an external clock input for the generator in the range 1kHz to 50MHz the input sensitivity is 0.5V pk-pk and the maximum amplitude is 5V pk-pk within the limits ± 5 V. This input is enabled by selection of the EXT position of the CLOCK SELECTION switch (1), it is an unbalanced input with an impedance of 75 ohms.
- (5) The CLOCK THRESHOLD switch selects the triggering threshold for external clock signals applied to both Generator and Receiver sections of the instrument via the CLOCK I/P connectors

(4) and (24). In the AUTO position the triggering is automatic at the mean signal level. In the GND position the triggering is at the instrument ground level.

- (6) The GENERATOR EXTERNAL CLOCK TRIGGER indicator lamp is 'on' when an external clock input at CLOCK I/P connector (4) is correctly triggered. The lamp will be 'off' if clock transitions are absent for more than 150ms.

Option 099

The OFFSET (Δf) control and the OFFSET position of the clock selection switch are deleted. All references to these in (1) and (3) above do not apply.

3-7. GENERATOR PATTERN CONTROLS

Determine the sequence generated.

- (7) The PRBS/WORD switch selects the pattern to be generated from fixed four bit words: 0000, 1000, 1010, 1100, 1111 or the value of n : 9, 15, 20. The value of n selected may be used to produce an n bit word or a $2^n - 1$ bit PRBS as selected with the $2^n - 1/n$ switch (8).

The PRBS/WORD switch is also used to preset a reference 4 bit word on a receiving instrument (16 bit word with options 001 or 003) in order to detect systematic errors.

- (8) When the PATTERN SELECTION switch (7) is in one of the $n = 9, 15$ or 20 positions the $2^n - 1/n$ switch either selects a $2^n - 1$ bit maximal length PRBS or an n bit word. The n bit word is selected at random as any consecutive n bits of the $2^n - 1$ PRBS continuously recycled. The content of the n bit word may be changed with the RUN switch (9).

- (9) The RUN switch selects the content of the n bit word by allowing the $2^n - 1$ bit PRBS to run normally when the switch is pressed and to return to continuous recycling of the current n bits when the switch is released.

- (10) The ZERO ADD/NORM/ERROR ADD switch selects data modification. In the ZERO ADD position the number of zeros, up to 999, selected with the ZEROS switch (11) are added between words or before the longest run of zeros in the PRBS. In the NORM (normal) position the generator produces repetitive WORD or PRBS patterns.

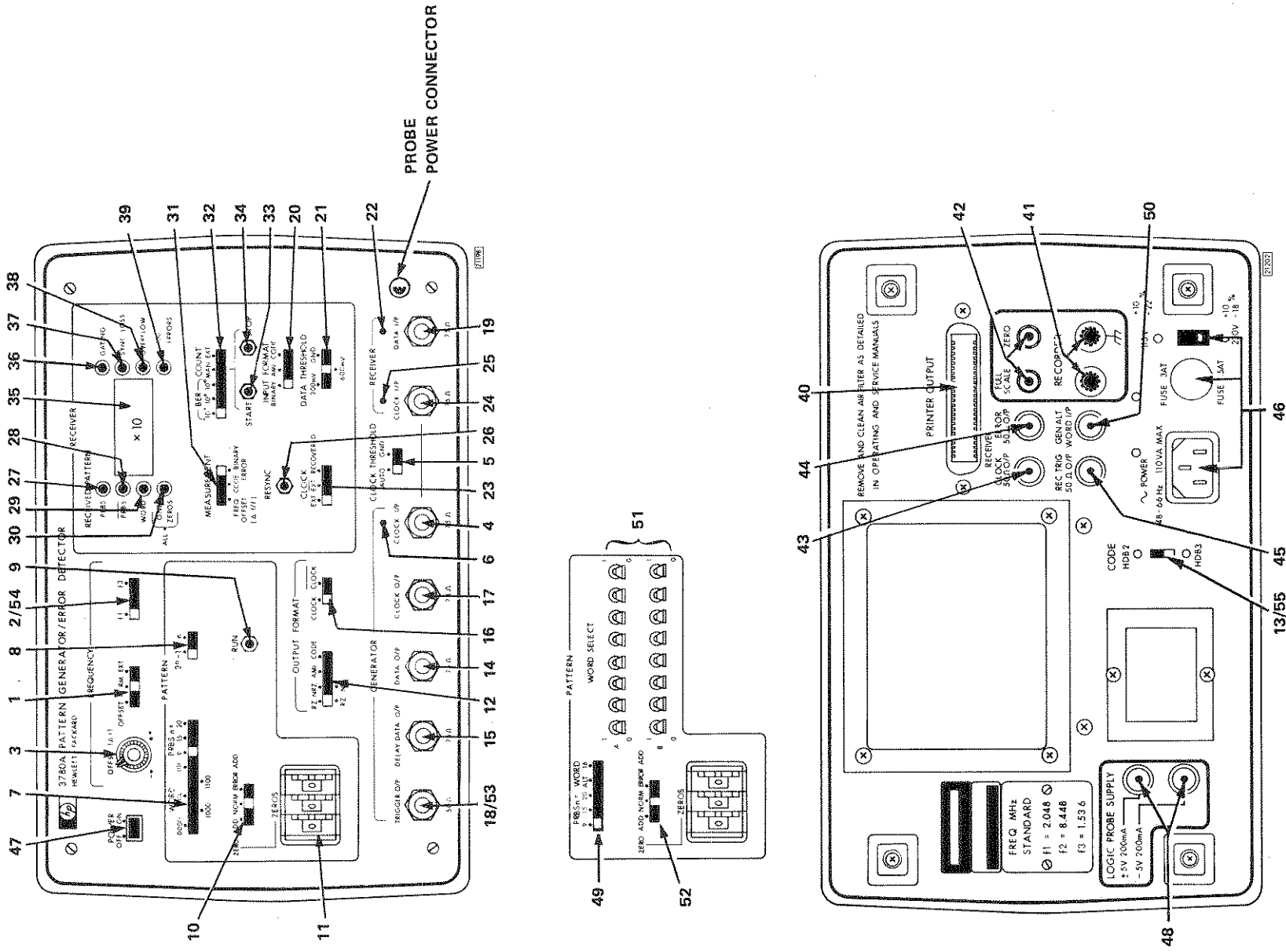

Figure 3-1 Front and Rear Panel Control Connector and Indicator References

The data is not modified and the sequence is determined by controls (7) (8) and (9) only. In the ERROR ADD position a fixed binary error rate of 10^{-2} is introduced into the generator sequence by producing 10 consecutive errors in every 1000 clock periods.

- (11) The ZEROS switch selects the number of zeros added to any pattern when the ZERO ADD position of the ZERO ADD/NORM/ERROR ADD switch (10) is selected.

3-8. GENERATOR FORMAT CONTROLS AND OUTPUT CONNECTORS

Determine generator output format.

- (12) The DATA FORMAT switch selects between binary and ternary data output formats. The binary data formats, RZ, return to zero, and NRZ, non return to zero are available at both DATA O/P (14) and DELAY DATA O/P (15) connectors. The ternary data formats, AMI, alternate mark inversion, and CODE, HDB3 or HDB2 (options 101 and 102 B6ZS or B3ZS), selected with the rear panel CODE switch are available at the DATA O/P connector (14) only.
- (13) The CODE switch on the rear panel selects HDB3 or HDB2 code formats (options 101 and 102 B6ZS or B3ZS) when the CODE position of the DATA FORMAT switch (12) is selected.
- (14) The DATA O/P connector provides a 75 ohm unbalanced data output as selected with the PATTERN and FORMAT controls. The output amplitude of the mark in binary formats is 3V and in ternary formats $\pm 2.37V$. The space in both formats is 0V. The connector has open and short circuit protection and will withstand an input of up to $\pm 6V$ for short periods.
- (15) The DELAY DATA O/P connector provides a data output of the binary formats RZ and NRZ, delayed by 6 bits less than a complete sequence i.e 6 bits advanced on the data at DATA O/P (14). In all other respects this output is identical to the normal data output.
- (16) The CLOCK/ $\overline{\text{CLOCK}}$ switch selects normal or inverted generator clock output at the CLOCK O/P connector (17).
- (17) The CLOCK O/P connector provides a 75 ohm unbalanced generator clock output. The output can be normal or inverted as selected with the CLOCK/ $\overline{\text{CLOCK}}$ switch (16) and the output frequency may be either an internal or external clock source. The output mark amplitude is 3V

and the space is 0V. The connector has both open and short circuit protection and will withstand an input of up to $\pm 6V$ for short periods.

- (18) The TRIGGER O/P connector provides one transition per word or sequence coincident with the start of the word and before the longest block of zeros of a PRBS. The amplitude of the trigger output is 1V and it is a 50 ohm unbalanced signal. The output has both open and short circuit protection and will withstand an input of up to $\pm 5V$ for short periods.

3-9. RECEIVER INPUT CONTROLS AND CONNECTORS

Set receiver clock and data input conditions.

- (19) The DATA I/P connector is a 75 ohm unbalanced input which accepts the data input for the receiver. The data input frequency range is 1Kb/s to 50Mb/s and the input sensitivity is 0.5V pk-pk. The maximum input amplitude is 5V pk-pk within the limits $\pm 5V$. The data triggering threshold can be selected with the DATA THRESHOLD switch (21).
- (20) The DATA FORMAT switch selects the appropriate binary or ternary receiver operation for incoming data at the DATA I/P connector (19). In the code position a choice of HDB3 or HDB2 code (options 101 and 102 B6ZS or B3ZS code) is provided with the rear panel CODE switch (13) which is common with the generator.
- (21) The DATA THRESHOLD switch selects the receiver data triggering level. Trigger level should be chosen to fall within 10% and 90% of data amplitude. Binary triggering levels of GND (ground), 200mV or 600mV may be selected. Ternary triggering levels of $\pm 200mV$ or $\pm 600mV$ may be selected.
- Note: In the recovered clock mode, threshold level should be set closest to 50% of maximum input data amplitude to allow the rising edge of the clock, after a fixed delay, to coincide with the centre of the data pulse.*
- (22) The DATA INPUT TRIGGER indicator lamp is 'on' when data applied to the DATA I/P connector (19) is correctly triggered. The lamp will be 'off' if data transitions are absent for more than 150mS.
- (23) The CLOCK switch selects the receiver clock source. In the EXT and $\overline{\text{EXT}}$ positions the receiver is clocked with a normal or inverted input applied to the RECEIVER CLOCK I/P connector (24). In

the RECOVERED position the receiver is clocked with a signal recovered from the data at the DATA I/P connector (19). The appropriate clock recovery frequency is selected with the FREQUENCY switch (2).

- (24) The CLOCK I/P connector is an unbalanced 75 ohm input for a receiver external clock in the frequency range 1kHz to 50MHz. The input sensitivity is 0.5V pk-pk and the maximum input amplitude is 5V pk-pk within the limits $\pm 5V$. The clock triggering threshold can either be ground or automatic [mean level of clock input as selected with the CLOCK THRESHOLD switch (5)]. The CLOCK THRESHOLD switch is common with the generator.
- (25) The RECEIVER CLOCK INPUT TRIGGER indicator lamp is 'on' when a clock signal applied to the CLOCK I/P connector (24) is correctly triggered. The lamp will be 'off' if clock transitions are absent for 150 ms.

3-10. SYNC AND SYNC INDICATORS

Automatic synchronisation with manual override and received pattern indication.

- (26) The RESYNC switch is a manual override on the automatic synchronisation system. When the RESYNC switch is pressed a search for synchronism is initiated. The incoming pattern is examined for parity with each of the possible incoming patterns until less than 4 errors occur in 100 clock periods. Synchronisation is then regained, and the type of pattern indicated by one of the synchronisation indicators (27) to (30).
- (27) PRBS The normal 2^9-1 , $2^{15}-1$ or $2^{20}-1$ bit PRBS produced by the generator.
- (28) $\overline{\text{PRBS}}$ The inverse of the 2^9-1 , $2^{15}-1$ or $2^{20}-1$ bit PRBS produced by the generator.
- (29) WORD Any word which is repetitive in blocks of 9, 12, 15, 16 or 20 bits and all zeros (any word sequence with less than 4 ones in 100 clock periods).
- (30) AIS ALARM INDICATION SIGNAL, being all ones (any word sequence with less than 4 zeros in 100 clock periods).

3-11. MEASUREMENT CONTROLS

Select, measurements to be made, display format, and time-base.

- (31) The MEASUREMENT switch selects the measurement to be performed.

In the FREQUENCY OFFSET ($\Delta f/f$) position the fractional difference between the standard and off-set frequencies of the generator section is measured. With the CLOCK SELECTION switch (1) set to OFFSET, the fractional frequency difference measured is the off-set selected with the OFFSET Δf control (3) divided by the frequency f selected with the FREQUENCY switch (2).

In the CODE ERRORS position the receiver monitors the input data at DATA I/P (19) for violations of the coding laws. The coding law is selected with the receiver DATA FORMAT switch (20) as either AMI or CODE and in the CODE position the type of code HDB3, HDB2 (option 101 and 102 B6ZS, B3ZS) is selected with the rear panel CODE switch (13) which is common with the generator. The result may either be displayed as a bit error rate or error count as selected with the TIMEBASE switch (32). The measurement range is 0.0×10^{-9} to 9.9×10^{-2} in BER 10^{10} , 0.0×10^{-7} to 1.0×10^0 in BER 10^6 or 10^8 , and 0.0×10^1 to 9.9×10^8 in COUNT.

As an alternative to violations of the coding laws, it is possible, with HDB2/HDB3 to measure violations of violations where an error is registered for each violation which has the same polarity as the previous violation. An internal switch A34S1, selects between measurements of the coding law errors (VOCAB) and measurements of violations of violations (VIOLS).

In the BINARY ERRORS position the receiver measures the binary errors on a binary or a coded input applied to the DATA I/P connector (19). The binary errors are measured on a bit by bit basis using a reference pattern generated in the receiver. The result may either be displayed as a bit error rate or error count as selected with the TIMEBASE switch (32). The measurement range is 0.0×10^{-9} to 4.0×10^{-2} in BER and 0.0×10^1 to 9.9×10^8 in COUNT.

If the test signal being received is one of the fixed 4 bit words, or with options 001 or 003 a 16 bit word, two methods of operation are available depending on the setting of the PRBS/WORD switch (7). With the PRBS/WORD switch set to 9, 15 or 20, the receiving instrument will synchronise to the incoming pattern irrespective of systematic errors. With the PRBS/WORD switch set to the relevant word, the error detector will only synchronise to that word.

- (32) The TIMEBASE switch selects the counter time-base interval over which errors are counted. The BER positions give a choice of 10^6 , 10^8 or 10^{10} clock periods for measurement gating. The

measurement result is automatically scaled and presented in the form $X.Y \times 10^{-n}$ with an indication if this result is computed from less than 100 errors (39). In the COUNT position errors are counted over a period either selected manually with the START and STOP switches (33) and (34) or externally by a command from an external printer. In this mode a positive going TTL pulse at pin 47 of the PRINTER OUTPUT connector (40) stops the counter and produces a print command. The counter normally restarts 400ms after the stop command however it is possible, with the change of an internal link, to hold the restart until the pulse at PRINTER OUTPUT pin 47 goes negative.

- (33) The START switch controls the start of the manual measurement gating period when the TIMEBASE switch (32) is in the COUNT MAN position. The count is initiated by the switch being depressed. This switch can also be used to restart a measurement when counting errors over 10^6 , 10^9 or 10^{10} clock periods.
- (34) The STOP switch stops the measurement when counting over a manually controlled timebase. The count is stopped by the switch being depressed.

3-12. DISPLAY AND FLAG INDICATORS

Present the result and indicate state of measurement.

- (35) The DISPLAY shows the measurement result. Frequency offset measurements are displayed in the form $XY \times 10^{-n}$. Code error and binary error measurements are displayed as BER in the form $X.Y \times 10^{-n}$ or as COUNT in the form $X.Y \times 10^{+n}$.
- (36) The GATING flag indicates that a measurement is in progress. The indicator will be 'off' for at least 500ms between measurements.
- (37) The SYNC LOSS flag indicates loss of receiver pattern synchronisation. The indicator is inhibited during code error and frequency offset measurement.
- Sync loss will also be indicated when the PRBS/WORD switch (7) is in one of the fixed 4 bit word positions which is different to the word being received. With options 001 and 003 sync loss will be indicated when the PRBS/WORD switch is set to 16 and the word selected with the WORD SELECT switches is different to the word being received.

Note: This does not apply if the PRBS/WORD switch is set to one of the PRBS positions, 9, 15 or 20 or if the internal SYSTEMATIC ERROR DETECTION switch A37S2 is set to OFF, as the error detector will then synchronise to any repetitive 9, 12, 15, 16 or 20 bit word.

- (38) The OVERFLOW flag indicates that the internal error or frequency count has reached or exceeded 10^9 .
- (39) The <100 ERRORS flag indicates that less than 100 errors were counted during the last error measurement. The indicator is inhibited during frequency offset measurements.

3-13. RECEIVER OUTPUTS

- (40) The PRINTER OUTPUT connector provides an 8421 BCD output of the measurement result and current flag signal. In the BER and COUNT MAN positions of the TIMEBASE switch (32) the print command is at the termination of the measurement and in the COUNT EXT position the print command is initiated by the printer providing a positive going TTL pulse at pin 47 of this connector. Further details of the printer output are given on page 3-13.
- (41) The RECORDER OUTPUT connectors provide a high impedance current source output suitable for connection to a chart recorder. The output comprises 16 current levels with a total variation of 1mA into an impedance of 10K ohms max. There is an eleven level indication of BER and a four level indication of count and the response time is 500ms minimum. Further details of the recorder output are given on page 3-13.
- (42) The RECORDER CALIBRATION switches provide 1mA for FULL SCALE and 0mA for ZERO calibration of a chart recorder connected to the RECORDER OUTPUT connectors (41).
- (43) The RECEIVER CLOCK output provides an output of the receiver clock signal for recovered or ext clock. The output amplitude is 1V min pk-pk and the pulse width is nominally the same as the clock with a 50% duty cycle for recovered clock. The connector has both open and short circuit protection and will withstand an input of up to $\pm 5V$ for short periods. The output impedance is 50 ohms.

- (44) The ERROR output connector provides one pulse per error. The output pulse amplitude is 1V min pk-pk and the pulse width is nominally the same as the clock mark. The connector has both open and short circuit protection and will withstand an input of up to ±5V for short periods. The impedance of this output is 50 ohms and the output is inhibited during sync loss.
- (45) The RECEIVER TRIGGER output provides one pulse per received PRBS sequence near the start of the longest zero block. The output pulse amplitude is 1V min pk-pk and the pulse width is nominally one clock period. The connector has both open and short circuit protection and will withstand an input of up to ±5V for short periods. The output impedance is 50 ohms.

3-14. POWER CONTROLS AND CONNECTORS

- (46) The POWER INPUT module comprises a supply voltage selection switch, the supply fuse and a socket for the power supply cable. Details of setting the supply voltage switch and fuse selection are given on page 2-1 Paragraph 2-8.

WARNING

Before connecting the instrument to the supply ensure that the voltage selector is in the correct position and that a fuse of the correct rating is fitted.

- (47) The POWER switch controls the ac power input to the instrument.
- (48) The LOGIC PROBE SUPPLY connectors provide power for a logic probe which may be required for the service or repair of the instrument. Both + and -5 volts are available and both supplies are internally fused at 200mA.

3-15. OPTION CONTROLS AND CONNECTORS

Option 001/003

Option 001 is the 16 bit word option and option 003 is the 16 bit word option with small Siemens connectors.

- (49) The PATTERN SELECTION switch selects the pattern to be generated. In the $n = 9, 15$ and 20 positions a maximal length PRBS of 2^{n-1} is produced as for the standard instrument. In the

$n = 16$ position the generator produces a repetitive 16 bit word whose content is selected with the WORD SELECT switches (51). In the ALT position the generator produces two 8 bit repetitive words A and B alternated by an external signal applied to the GEN ALT WORD I/P connector (50) on the rear panel. The word 'A' is selected by a positive going transition of the input signal and the word 'B' by a negative going transition.

- (50) The GEN ALT WORD I/P connector accepts a signal to switch between words A and B as selected with the WORD SELECT switches (51). The input sensitivity is 250mV pk-pk for a dc to 100kHz square wave or 0.5V for a 200Hz to 100kHz sine or triangular wave. The input impedance is nominally 1K ohm and the maximum voltage is 15V rms.
- (51) The WORD SELECT switches select the content of the 16 bit or two 8 bit words produced by the generator.

- (10)/(52) The ZERO ADD/NORM/ERROR ADD switch performs the same function as in the standard instrument as described on page 3-2. Zeros are added once per sequence to the 16 bit word between words or individually to the 8 bit words.

- (18)/(53) The TRIGGER output socket provides a trigger output of one transition per word or sequence as for the standard instrument described on page 3-3. With the 16 bit word the transition occurs before each word and in the alternate mode the transition occurs before each 8 bit word A or B. All other controls, connectors and indicators are the same as the standard instrument.

Option 002

Option 002 instruments have small Siemens connectors in place of the 75 ohm BNC connectors. All other controls, connectors and indicators are the same as in the standard instrument.

Option 100

- (2)/(54) The internal crystal frequencies selected with the FREQUENCY switch are as follows:
 f_1 2,048kHz f_2 8,448kHz f_3 34,368kHz.
 These frequencies are listed on the rear panel of the instrument. All other controls, connectors and indicators are the same as in the standard instrument.

Option 101

- (2)/(54) The internal crystal frequencies selected with the FREQUENCY switch are as follows:

f_1 1,554kHz f_2 6,312kHz f_3 44,736kHz

These frequencies are listed on the rear panel of the instrument.

When the 3780A is used at $f_3 = 44.736$ Mb/s with a ternary coded O/P and I/P format, the shape of an isolated data O/P pulse conforms to a CCITT pulse mask (CCITT recommendation G703.4). An equaliser (operational when f_3 and ternary coded data is selected), incorporated at the data I/P port, automatically compensates for interstation cable losses up to 12dB at $fc/2$ ($fc = 44.736$ Mb/s) from a 0.909V pk source.

- (13)/(55) The rear panel CODE switch selects B3ZS and B6ZS code formats in the generator and receiver.

All other controls, connectors and indicators are the same as in the standard instrument.

Option 102

- (2)/(54) The internal crystal frequencies selected with the FREQUENCY switch are as follows:

f_1 1,554kHz f_2 6,312kHz f_3 3,152kHz

These frequencies are listed on the rear panel of the instrument.

- (13)/(55) The rear panel CODE switch selects B3ZS and B6ZS code formats in the generator and receiver.

All other controls, connectors and indicators are the same as in the standard instrument.

Option 099

- (1)/(3) The frequency OFFSET (Δf) control and the OFFSET position of the clock selection switch are deleted.

All other controls, connectors and indicators are the same as in the standard instrument.

3-16. OPERATORS CHECK

3-17. The Operators checks allow the operator to check the main functions of the instrument prior to use. A complete specification check is given in Section IV Performance Tests. The Operators Checks may be performed individually or in any order. The control resetting information at the

end of each check applies to the checks when they are performed in the order given.

3-18. Equipment Required

3-19. Details of the equipment required for the Operators Checks are given in Table 1-3 Page 1-10. A summary of this equipment is given below:

- (a) Signal Generator 50MHz recommended type hp 8654A.
- (b) Matching Pad 50/75 Ω
- (c) Three 75 Ω cables, two of which should be of the same length and construction ie they should have the same delay.

3-20. The Signal Generator and matching pad are used to check the external clock input and to reduce the time taken for the BER, Count and Display Checks. It is possible to perform the BER, Count and Display checks using the internal clock, the measurement time however will depend on the frequency used. The BER 10^{10} check on Page 3-11 which takes 3 minutes 20 seconds at 50MHz will take more than 26 minutes at 6312kHz.

3-21. Preparation for the Operators Check

3-22. Before proceeding with the operators checks:

- (a) Make a note of the option number of the instrument as given on the rear panel.
- (b) Using two 75 Ω cables of the same length and similar construction connect the GENERATOR CLOCK O/P to the RECEIVER CLOCK I/P and the GENERATOR DATA O/P to the RECEIVER DATA I/P.
- (c) Open Page 4-1 so that Figure 4-1 can be used for reference while performing the Operators Checks.

Note: In some of the following checks the instrument will lose synchronisation during the setting up procedure and the SYNC LOSS lamp will come on. Unless otherwise stated the check relates to the condition after synchronisation has been regained.

3-23. CHECK PROCEDURES**3-24. Frequency and Offset Checks**

Set all controls to the reference settings given on Page 4-1 and perform the procedure given in Table 3-2

Table 3-2 Frequency and Offset Check Procedure

Procedure	Check
Switch the POWER ON.	RECEIVER CLOCK I/P lamp on. RECEIVER DATA I/P lamp on. PRBS lamp on. <100 ERRORS lamp on. DISPLAY 0.0×10^{-5} GATING lamp FLASHING
Set the f1/f2/f3 switch to f2.	GATING lamp FLASHING
Set the F1/f2/f3 switch to f3.	GATING lamp FLASHING
Set the OFFSET/NORM/EXT switch to OFFSET. Set the RECEIVER MEASUREMENT switch to FREQ OFFSET (Δf).	The displayed offset increases from 0.0×10^{-6} when the OFFSET (Δf) control is varied in either direction from its mid position.
Set the f1/f2/f3 switch to f2.	The displayed offset increases from 0.0×10^{-6} when the OFFSET (Δf) control is varied in either direction from its mid position.
Set the f1/f2/f3 switch to f1.	The displayed offset increases from 0.0×10^{-6} when the OFFSET (Δf) control is varied in either direction from its mid position.
To reset the controls to the reference settings as required for the Pattern and Synchronisation checks: Set the OFFSET/NORM/EXT switch to NORM and the RECEIVER MEASUREMENT switch to BINARY ERROR.	

3-25. Pattern and Synchronisation Checks

Set all controls to the reference settings given on page 4-1.

Instruments without options 001 or 003 perform the procedures given in Table 3-3. Instruments with options 001 or 003 perform the procedure given in Table 3-4.

Table 3-3 Pattern and Synchronisation Check Procedure (Instruments without options 001 or 003).

Procedure	Check
Set the WORD/PRBS switch to 15.	SYNC LOSS lamp on briefly. PRBS lamp ON.
Set the WORD/PRBS switch to 20.	SYNC LOSS lamp on briefly. PRBS lamp ON.
Set the $2^n - 1/n$ switch to n.	WORD lamp ON.
Set the WORD/PRBS switch to 15.	SYNC LOSS lamp on briefly. WORD lamp ON.
Set the WORD/PRBS switch to 9. Press and hold the RUN pushbutton.	PRBS lamp ON
Release the RUN pushbutton.	WORD lamp ON.

**Table 3-3 Pattern and Synchronisation Check Procedure
(Instruments without options 001 or 003) (continued)**

Procedure	Check
Press and hold the RESYNC pushbutton.	SYNC LOSS lamp ON.
Set the WORD/PRBS switch to 0000.	WORD lamp ON.
Set the WORD/PRBS switch to 1000.	WORD lamp ON.
Set the WORD/PRBS switch to 1111.	AIS lamp ON.
To reset the controls to the reference settings as required for the Format Checks: Set the WORD/PRBS switch to 9 and set the $2^n-1/n$ switch to 2^n-1 .	

**Table 3-4 Pattern and Synchronisation Check Procedure
(Instruments with options 001 or 003).**

Procedure	Check
Set the PRBS/WORD switch to 20.	SYNC LOSS lamp on briefly. PRBS lamp ON.
Set the PRBS/WORD switch to 15.	SYNC LOSS lamp on briefly. PRBS lamp ON.
Set the PRBS/WORD switch to 9.	SYNC LOSS lamp on briefly. PRBS lamp ON.
Press and hold the RESYNC pushbutton.	SYNC LOSS lamp ON.
Release the RESYNC pushbutton.	PRBS lamp ON.
Set the PRBS/WORD switch to 16.	WORD lamp ON.
Set the WORD SELECT switches as follows: A 10000000 B 00000000	WORD lamp ON.
Set the WORD SELECT switches as follows: A 11111111 B 11111110	WORD lamp on at each stage of switching.
Set the WORD SELECT switches as follows: A 11111111 B 11111111	AIS lamp ON.
To reset the controls to the reference settings as required for the Format Checks: Set the PRBS/WORD switch to 9 and set all WORD SELECT switches to 0.	

3-26. Format Checks

Set all controls up to the reference settings given on page 4-1 and perform procedures given in Table 3-5.

Table 3-5 Format Check Procedure

Procedure	Check
Set the ZERO ADD/NORM/ERROR ADD Switch to ERROR ADD.	DISPLAY 1.0×10^{-2}
Set the CLOCK/ $\overline{\text{CLOCK}}$ switch to $\overline{\text{CLOCK}}$.	All ONES ZEROS lamp ON
Set the RECEIVER CLOCK switch to $\overline{\text{EXT}}$.	PRBS lamp ON
Reset the CLOCK/ $\overline{\text{CLOCK}}$ switch to CLOCK. Disconnect the cable between the GENERATOR CLOCK O/P and the RECEIVER CLOCK I/P. Set the RECEIVER CLOCK switch to RECOVERED.	PRBS lamp ON.
Add an extra $4 \pm \frac{1}{8}$ ft (1.2912 ± 0.15 m) to the cable from the GENERATOR CLOCK O/P and reconnect to the RECEIVER CLOCK I/P. Reset the RECEIVER CLOCK; switch to EXT.	
Set the WORD/PRBS switch to 1111 (options 001 and 003 to 16 with the WORD SELECT switches at 111100000111100). Set the ZERO ADD/NORM/ERROR ADD Switch to ZERO ADD. Set the ZEROS switch to 006 (options 001 and 003 set the zeros switch to 004). Set the RECEIVER INPUT FORMAT switch to AMI. Set the RECEIVER MEASUREMENT switch to CODE ERROR.	DISPLAY 4.0×10^{-1}
Set the OUTPUT FORMAT switch to AMI. Set the RECEIVER INPUT FORMAT switch to CODE.	DISPLAY 0.0×10^{-5} DISPLAY 3.0×10^{-1} (HDB3) options 101 and 102 1.0×10^{-1} (B6ZS)
Set the OUTPUT FORMAT switch to CODE.	DISPLAY 0.0×10^{-5}
Reset the OUTPUT FORMAT switch to AMI. Set the rear panel CODE switch to HDB2 (options 101 and 102, B3ZS).	DISPLAY 4.0×10^{-1} (HDB2 and B3ZS)
Set the OUTPUT FORMAT switch to CODE.	DISPLAY 0.0×10^{-5}
Reset the rear panel CODE. Switch to HDB3 (options 101, and 102, B6ZS). Reset the RECEIVER INPUT FORMAT switch to AMI. Reset the OUTPUT FORMAT switch to RZ.	DISPLAY 4.0×10^{-1}
Set the ZEROS switch to 996 (options 001 and 003 set the ZEROS switch to 984 with the WORD SELECT switches at 11110000 00000000)	DISPLAY 4.0×10^{-3}

Continued on Page 3-11.

Table 3-5 Format Check Procedure (continued)

Procedure	Check
Disconnect the cable from the GENERATOR DATA O/P and connect the GENERATOR DELAYED DATA O/P to the RECEIVER DATA I/P. To reset the controls as required for the COUNT, BER and Display, Checks: Disconnect the cable from the GENERATOR DELAYED DATA O/P and connect the GENERATOR DATA O/P to the RECEIVER DATA I/P. Set the WORD/PRBS switch to 1000 (options 001 and 003 to 16 with the WORD SELECT switches at 10000000 00000000).	DISPLAY 4.0×10^{-3}

3-27. Count, BER and Display Checks

Set all controls to the reference settings given on Page 4-1 with the following exceptions:
 Set the WORD/PRBS switch to 1000 (options 001 and 003 to 16 with the WORD SELECT switches at 1000 0000 0000 0000).

Set the ZERO ADD/NORM/ERROR ADD switch to ZERO ADD.
 Set the ZERO switch to 996 (options 001 and 003 to 984).
 Set the RECEIVER INPUT FORMAT switch to AMI.
 Set the RECEIVER MEASUREMENT switch to CODE ERROR.
 Perform the procedure given in Table 3-6.

Table 3-6 Count, BER and Display Check Procedure

Procedure	Check
Set the RECEIVER BER/COUNT Switch to COUNT MAN. Press the STOP pushbutton. Set the WORD/PRBS switch to 1111 (options 001 and 003 to 16 with all WORD SELECT switches at 1). Set the ZERO ADD/NORM/ERROR ADD switch to NORM. Set the OFFSET/NORM/EXT switch to EXT. With the generator-receiver clock and data cables still connected, connect the 8654A Signal Generator, set to 50MHz, to the GENERATOR CLOCK I/P via a $50/75\Omega$ matching pad. If a Signal Generator is not available see paragraph 3-20. Set the Signal Generator to produce a 500mV peak-to-peak signal at the GENERATOR CLOCK I/P. Press the START pushbutton.	Display counting up. The count is held and displayed. GENERATOR CLOCK I/P lamp ON. The count increases to 9.9×10^8 . The display blanks with the GATING lamp OFF and the OVERFLOW lamp ON. NOTE, measurement time 20 seconds.

Continued on Page 3-12

Table 3-6 Count, BER and Display Check Procedure (continued)

Procedure	Check
Set the RECEIVER BER/COUNT switch to BER 10^6 .	GATING lamp FLASHING DISPLAY 1.0×10^{-6}
Set the RECEIVER BER/COUNT switch to BER 10^8	GATING lamp FLASHING DISPLAY 1.0×10^{-8} NOTE, measurement time 2 seconds
Set the RECEIVER BER/COUNT switch to BER 10^{10}	GATING lamp ON. After approximately 20 seconds OVERFLOW lamp ON.
Set the ZERO ADD/NORM/ERROR ADD Switch to ZERO ADD. Set the ZEROS switch to 037, (options 001 and 003 to 025 with the WORD SELECT switches at 11110000 0000 0000). Press the START pushbutton.	OVERFLOW lamp OFF. GATING lamp ON. After approximately 3 minutes 20 seconds DISPLAY 9.8×10^{-2}

3-28. OPERATING PROCEDURE

3-29. INTRODUCTION

3-30. The 3780A PATTERN GENERATOR/ERROR DETECTOR measures binary errors, code errors, and frequency offset. The measurements may be local using a loop back method or through a channel under test to a remote error detector.

3-31. BINARY OR CODE ERROR MEASUREMENTS

3-32. To make Binary Error or Code Error measurements proceed as follows:

3-33. Generator

1. Select the generator FREQUENCY either internal (NORM) f_1 f_2 f_3 or external (EXT) from the CLOCK I/P.
2. Select the generator pattern $2^n - 1$ PRBS, n bit word or one of the fixed words.
3. Select the generator output format, RZ or NRZ for binary outputs, AMI or CODE including rear panel CODE format for code outputs.
4. Connect the generator DATA O/P to the item under test.
5. If not using recovered clock connect the generator CLOCK O/P to item under test.

3-34. Receiver

6. Connect data from item under test to receiver DATA I/P.
7. If not using recovered clock connect clock from item under test to CLOCK I/P.
8. Select DATA THRESHOLD 200mV, 600mV or GND.
9. Select receiver CLOCK drive EXT, $\overline{\text{EXT}}$ or RECOVERED.
10. Select INPUT FORMAT BINARY (RZ or NRZ), AMI or CODE.

Note: The code will be the code selected with the rear panel CODE switch of the receiving instrument.

11. Select MEASUREMENT to be made CODE ERRORS or BINARY ERRORS.
12. If the generator pattern selected in step 2 was one of the fixed words and systematic error detection is required, select the same fixed word with the PRBS/WORD switch of the receiving instrument. If systematic error detection is not required, select one of the PRBS (9, 15 or 20) positions of the PRBS/WORD switch on the receiving instrument.

For HDB2/HDB3 code errors, select vocabulary errors (VOCAB) or violations of violations (VIOLS) with internal switch A34S1.

13. For Binary Errors ensure that synchronism has been achieved by observation of the RECEIVED PATTERN indicators.
14. Select TIMEBASE and DISPLAY MODE, BER over 10^6 10^8 or 10^{10} clock periods or COUNT, MANUAL or EXTERNAL.

Note: In BER the measurement starts automatically in COUNT MANUAL the measurement is initiated with the START switch, and in COUNT EXTERNAL the measurement is initiated from an external printer.

15. Ensure that the receiver is operating correctly by observing the GATING indicator.

3-35. FREQUENCY OFFSET MEASUREMENT

3-36. To set a required generator offset proceed as follows:

1. Select the generator FREQUENCY f_1 f_2 or f_3 .
2. Select the OFFSET position of the generator CLOCK SELECTION switch.
3. Set the receiver MEASUREMENT to FREQUENCY OFFSET.
4. Ensure correct operation by observing the display and GATING indicator.
5. Adjust the generator OFFSET control to give a display of the required offset.

3-37. To measure the offset of an external data input proceed as follows:

1. Connect the external data input to the receiver DATA I/P connector.
2. Select the RECOVERED position of the receiver CLOCK format switch.
3. Connect the receiver CLOCK output on the rear panel to the generator CLOCK I/P.
4. Set the generator CLOCK SELECTION to EXT.
5. Select the comparison frequency with the generator FREQUENCY switch f_1 f_2 or f_3 .
6. Set the receiver MEASUREMENT to FREQUENCY OFFSET.
7. Ensure correct operation by observing the display and GATING indicator.

3-38. To measure the offset of an external clock input connect the external clock input to the generator CLOCK I/P and proceed as in steps 4 to 7 above.

3-39. CONNECTION OF ASSOCIATED INSTRUMENTS

3-40. INTRODUCTION

3-41. The outputs provided for external recording or display of the measurement results are described in this section. The outputs covered are for a printer, a chart recorder and a counter.

3-42. PRINTER

3-43. The printer output is designed for direct use with a Hewlett-Packard 5055A 5050B or 5150A printer. The information from flag signals and display is presented for a 10 column print out in the form:

$F * X * Y * 10 \pm N$

Where F represent the flag information and the remaining digits represent a BER or COUNT display in the form $X.Y \times 10 \pm N$. The output information is in 8421 BCD form and print information between the error detector and printer is carried on two lines. The error detector Printer output socket connections are as follows:

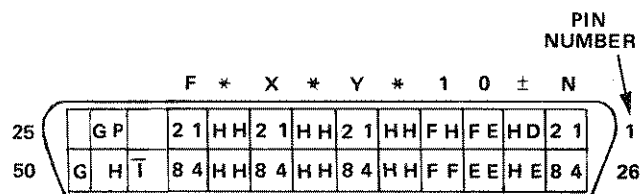

KEY

- 1, 2, 4, 8 BCD WEIGHTING
- D HIGH FOR + LOW FOR --
- E LOW EXCEPT DURING SYNC LOSS OR OVERFLOW FLAGS
- F LOW EXCEPT DURING SYNC LOSS OR OVERFLOW FLAGS
- G GROUND
- H PERMANENT HIGH
- I INHIBIT 3780A COUNT CONTROL FROM PRINTER
- P PRINT COMMAND FROM 3780A TO PRINTER

Figure 3-2 Printer Output Socket as Viewed on Rear Panel

The flag signal information is coded as follows:

PRINT OUT	FLAG
1	OVERFLOW
2	SYNC LOSS
3	CLOCK LOSS
4	DATA LOSS
V	LESS THAN 100 ERRORS
A	AIS

Note: On standard Hewlett-Packard 5055A and 5050B printers V is produced for decimal 13 or binary 1101 print commands.

3-44. The print command in the BER mode of operation is given at the termination of each measurement. The print command in COUNT MANUAL is given when the STOP switch is pressed and in COUNT EXTERNAL on receipt of a stop command from the printer. The print command is a TTL pulse and the minimum print cycle time is 500ms.

3-45. RECORDER

3-46. The recorder output provides a high impedance current source output suitable for connection to a chart recorder. The output comprises 16 current levels with a total variation of 1mA into an impedance of 10K ohms max. Two pushbutton switches give Full scale and Zero outputs for setting up the recorder and there are internal adjustments for range 1mA ± 0.2mA and centre 0 to 0.5mA. The minimum response time is 500ms. The output levels are as follows:

Level 15 = FSD

BER: Thirteen level signal

	LEVELS	BER
FSD	15	< 10 ⁻⁸
	14	< 10 ⁻⁷
	13	< 10 ⁻⁶
	12	< 10 ⁻⁵
	11	< 10 ⁻⁴
	10	< 10 ⁻³
	9	< 10 ⁻²
	8	< 10 ⁻¹
	7	< 10 ⁰
	6	< 10 ⁰
	4	Sync loss
	2	AIS
	0	Signal loss

COUNT: Five level signal

	LEVELS	REFERENCE
FSD	15	Signal no errors } except
	7	Signal plus errors } AIS
	4	Sync loss
	2	AIS
	0	Signal loss

Signal loss indicates clock loss when using an external clock and data loss when using recovered clock.

3-47. COUNTER

3-48. To make large error counts with greater resolution than is possible on the 3780A display an external counter may be connected to the rear panel ERROR output socket. The output is one pulse per error, the pulse amplitude being 1V pk-pk minimum. The output is inhibited during sync loss.

3-49. OPERATORS MAINTENANCE

3-50. The only routine maintenance which should be performed by the operator is the cleaning of the air filter as described in Paragraph 3-51.

CAUTION

The replacement of blown fuses should not be performed without reference to the power supply troubleshooting procedure Page 8-55. Power supply assembly damage can result if the correct procedure is not carried out.

3-51. Air Filter Cleaning

3-52. The instrument has an air intake filter which is fixed to the rear panel with four screws. This filter should be removed and cleaned at intervals of approximately one month, depending on environment. Wash the filter mesh in clean soapy water, rinse thoroughly and dry before re-fitting.

WARNING

The instrument should not be operated with the air filter removed and the fan blades exposed.

