

# Makita

AMERICA

## Cordless Driver Drill

Equipped with Electric Brake

**MODEL 6203DWAE**

With Fast Charger

### INSTRUCTION MANUAL

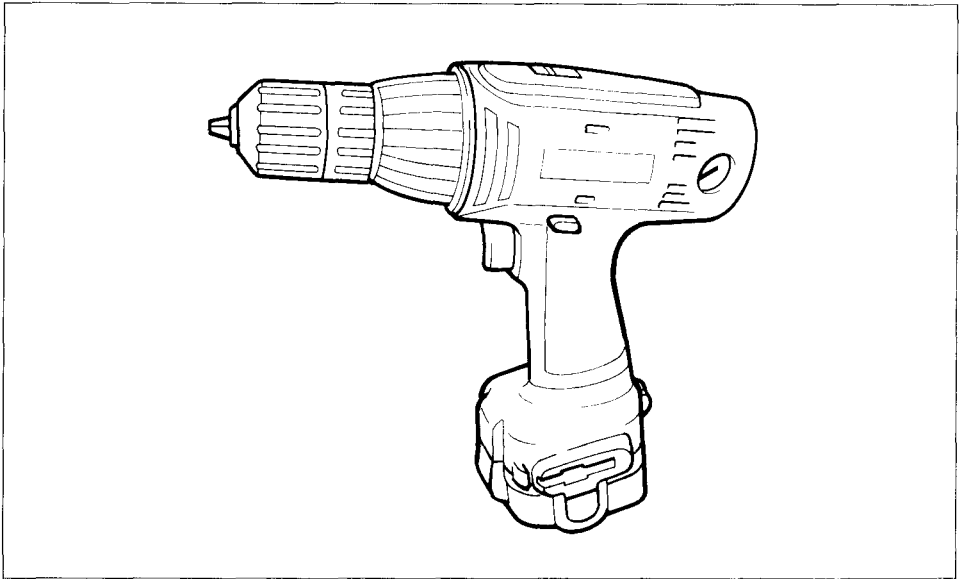

#### SPECIFICATIONS

• Model 6203DA

Capacities				No load speed (RPM)		Dimensions (L x W x H)	Net weight
Steel	Wood	Wood screw	Machine screw	High	Low		
10 mm (3/8")	25 mm (1")	6.4 mm x 76 mm (1/4" x 3")	6 mm (1/4")	0 - 1,200	0 - 400	233 mm x 77 mm x 241 mm (9-1/8" x 3" x 9-1/2")	1.7 kg (3.8 lbs)

• Battery Cartridge 9122

• Model DC1410 Fast Charger

Voltage	Input	Output	Charging time
9.6 V	A.C. only 50 Hz 60 Hz	D.C. 7.2 V - 14.4 V	1 Hr.

\* Manufacturer reserves the right to change specifications without notice.

\* Note: Specifications may differ from country to country.

WARNING: For your personal safety, READ and UNDERSTAND before using.

SAVE THESE INSTRUCTIONS FOR FUTURE REFERENCE.

# GENERAL SAFETY RULES

## (For All Battery Operated Tools)

**WARNING!** Read and understand all instructions. Failure to follow all instructions listed below, may result in electric shock, fire and/or serious personal injury.

## SAVE THESE INSTRUCTIONS

### Work Area

- **Keep your work area clean and well lit.** Cluttered benches and dark areas invite accidents.
- **Do not operate power tools in explosive atmospheres, such as in the presence of flammable liquids, gases, or dust.** Power tools create sparks which may ignite the dust or fumes.
- **Keep bystanders, children, and visitors away while operating a power tool.** Distractions can cause you to lose control.

### Electrical Safety

- **Do not abuse the cord. Never use the cord to carry the tool. Keep cord away from heat, oil, sharp edges, or moving parts. Replace damaged cords immediately.** Damaged cords may create a fire.
- **A battery operated tool with integral batteries or a separate battery pack must be recharged only with the specified charger for the battery.** A charger that may be suitable for one type of battery may create a risk of fire when used with another battery.
- **Use battery operated tool only with specifically designated battery pack.** Use of any other batteries may create a risk of fire.

### Personal Safety

- **Stay alert, watch what you are doing, and use common sense when operating a power tool. Do not use tool while tired or under the influence of drugs, alcohol, or medication.** A moment of inattention while operating power tools may result in serious personal injury.
- **Dress properly. Do not wear loose clothing or jewelry. Contain long hair. Keep your hair, clothing, and gloves away from moving parts.** Loose clothes, jewelry, or long hair can be caught in moving parts.
- **Avoid accidental starting. Be sure switch is in the locked or off position before inserting battery pack.** Carrying tools with your finger on the switch or inserting the battery pack into a tool with the switch on invites accidents.
- **Remove adjusting keys or switches before turning the tool on.** A wrench or a key that is left attached to a rotating part of the tool may result in personal injury.
- **Do not overreach. Keep proper footing and balance at all times.** Proper footing and balance enable better control of the tool in unexpected situations.

- **Use safety equipment. Always wear eye protection.** Dust mask, non-skid safety shoes, hard hat, or hearing protection must be used for appropriate conditions.

### **Tool Use and Care**

- **Use clamps or other practical way to secure and support the workpiece to a stable platform.** Holding the work by hand or against your body is unstable and may lead to loss of control.
- **Do not force tool. Use the correct tool for your application.** The correct tool will do the job better and safer at the rate for which it is designed.
- **Do not use tool if switch does not turn it on or off.** A tool that cannot be controlled with the switch is dangerous and must be repaired.
- **Disconnect battery pack from tool or place the switch in the locked or off position before making any adjustments, changing accessories, or storing the tool.** Such preventive safety measures reduce the risk of starting the tool accidentally.
- **Store idle tools out of reach of children and other untrained persons.** Tools are dangerous in the hands of untrained users.
- **When battery pack is not in use, keep it away from other metal objects like: paper clips, coins, keys, nails, screws, or other small metal objects that can make a connection from one terminal to another.** Shorting the battery terminals together may cause sparks, burns, or a fire.
- **Maintain tools with care. Keep cutting tools sharp and clean.** Properly maintained tools with sharp cutting edge are less likely to bind and are easier to control.
- **Check for misalignment or binding of moving parts, breakage of parts, and any other condition that may affect the tool's operation. If damaged, have the tool serviced before using.** Many accidents are caused by poorly maintained tools.
- **Use only accessories that are recommended by the manufacturer for your model.** Accessories that may be suitable for one tool may create a risk of injury when used on another tool.

### **Service**







- **Tool service must be performed only by qualified repair personnel.** Service or maintenance performed by unqualified personnel may result in a risk of injury.
- **When servicing a tool, use only identical replacement parts. Follow instructions in the Maintenance section of this manual.** Use of unauthorized parts or failure to follow Maintenance Instructions may create a risk of shock of injury.

## ***Specific Safety Rules***

- 1. Hold tool by insulated gripping surfaces when performing an operation where the cutting tool may contact hidden wiring.** Contact with a "live" wire will also make exposed metal parts of the tool "live" and shock the operator.
- 2. Be aware that this tool is always in an operating condition, because it does not have to be plugged into an electrical outlet.**
- 3. Always be sure you have a firm footing.**  
**Be sure no one is below when using the tool in high locations.**
- 4. Hold the tool firmly.**
- 5. Keep hands away from rotating parts.**
- 6. Do not leave the tool running. Operate the tool only when hand-held.**
- 7. Do not touch the drill bit or the workpiece immediately after operation; they may be extremely hot and could burn your skin.**

# SYMBOLS

The followings show the symbols used for tool.

V	.....	volts
A	.....	amperes
Hz	.....	hertz
kg	.....	kilograms
h	.....	hours
min	.....	minutes
s	.....	seconds
	.....	alternating current
	.....	direct current
$n_b$	.....	no load speed
	.....	alternating or direct current
	.....	Class II Construction
	.....	splash-proof construction
	.....	watertight construction
.../min	.....	revolutions or reciprocation per minute
	.....	number of blow

# IMPORTANT SAFETY INSTRUCTIONS FOR CHARGER & BATTERY CARTRIDGE

- 1. SAVE THESE INSTRUCTIONS** – This manual contains important safety and operating instructions for battery charger.
2. Before using battery charger, read all instructions and cautionary markings on (1) battery charger, (2) battery, and (3) product using battery.
3. **CAUTION** – To reduce risk of injury, charge only **MAKITA Battery Cartridge 7000, 7001, 7002, 9000, 9001, 9002, 9100, 9101, 9101A, 9102, 9102A, 9122, 1200, 1201, 1201A, 1202, 1202A, 1210, 1211, 1222 OR 1422.** Other types of batteries may burst causing personal injury and damage.
4. Do not expose charger to rain or snow.
5. Use of an attachment not recommended or sold by the battery charger manufacturer may result in a risk of fire, electric shock, or injury to persons.
6. To reduce risk of damage to electric plug and cord, pull by plug rather than cord when disconnecting charger.
7. Make sure cord is located so that it will not be stepped on, tripped over, or otherwise subjected to damage or stress.
8. An extension cord should not be used unless absolutely necessary. Use of improper extension cord could result in a risk of fire and electric shock. If extension cord must be used, make sure:
  - a. That pins on plug of extension cord are the same number, size, and shape as those of plug on charger;
  - b. That extension cord is properly wired and in good electrical condition; and
  - c. That wire size is at least as large as the one specified in the table below.

**TABLE 1**  
**RECOMMENDED MINIMUM AWG SIZE FOR**  
**EXTENSION CORDS FOR BATTERY CHARGERS**

Length of Cord (Feet)	25	50	100	150
AWG Size of Cord	18	18	18	16

9. Do not operate charger with damaged cord or plug – replace them immediately.
10. Do not operate charger if it has received a sharp blow, been dropped, or otherwise damaged in any way; take it to a qualified serviceman.
11. Do not disassemble charger or battery cartridge; take it to a qualified serviceman when service or repair is required. Incorrect reassembly may result in a risk of electric shock or fire.
12. To reduce risk of electric shock, unplug charger from outlet before attempting any maintenance or cleaning. Turning off controls will not reduce this risk.

## **ADDITIONAL SAFETY RULES FOR CHARGER & BATTERY CARTRIDGE**

1. Do not charge Battery Cartridge when temperature is BELOW 10°C (50°F) or ABOVE 40°C (104°F).
2. Do not attempt to use a step-up transformer, an engine generator or DC power receptacle.
3. Do not allow anything to cover or clog the charger vents.
4. Always cover the battery terminals with the battery cover when the battery cartridge is not used.
5. A battery short can cause a large current flow, overheating, possible burns and even a breakdown.
  - (1) Do not touch the terminals with any conductive material.
  - (2) Avoid storing battery cartridge in a container with other metal objects such as nails, coins, etc.
  - (3) Do not expose battery cartridge to water or rain.
6. Do not store the tool and Battery Cartridge in locations where the temperature may reach or exceed 50°C (122°F).
7. Do not incinerate the Battery Cartridge even if it is severely damaged or is completely worn out. The battery cartridge can explode in a fire.

**SAVE THESE INSTRUCTIONS.**

### Installing or removing battery cartridge

- Always switch off the tool before insertion or removal of the battery cartridge.
- To remove the battery cartridge, withdraw it from the tool while pressing the buttons on both sides of the cartridge.
- To insert the battery cartridge, align the tongue on the battery cartridge with the groove in the housing and slip it into place. Always insert it all the way until it locks in place with a little click. If not, it may accidentally fall out of the tool, causing injury to you or someone around you.

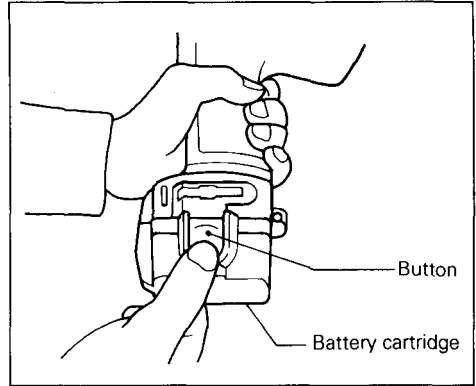

- Do not use force when inserting the battery cartridge. If the cartridge does not slide in easily, it is not being inserted correctly.

### Charging

- Your new battery cartridge is not charged. You will need to charge it before use. Use the fast charger Model DC1410 to charge the battery cartridge.
- Plug the fast charger into the proper A.C. voltage source. The charging light will flash in green color.
- Insert the battery cartridge so that the plus and minus terminals on the battery cartridge are on the same sides as their respective markings on the fast charger. Insert the cartridge fully into the port so that it rests on the charger port floor.

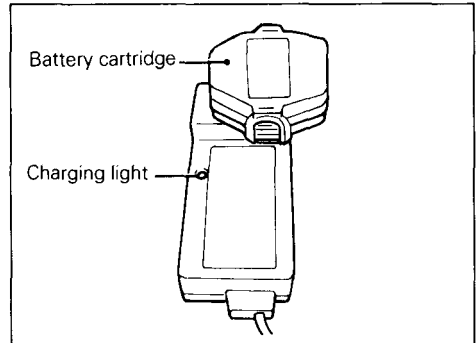

- When the battery cartridge is inserted, the charging light color will change from green to red and charging will begin. The charging light will remain lit steadily during charging.
- When charging is completed, the charging light color will change from red to green. The charging time is approximately one hour.
- After charging, unplug the charger from the power source.

### CAUTION:

- The fast charger Model DC1410 is for charging Makita battery cartridge. Never use it for other purposes or for other manufacturer's batteries.
- When you charge a new battery cartridge or a battery cartridge which has not been used for a long period of time, it may not accept a full charge. This is a normal condition and does not indicate a problem. You can recharge the battery cartridge fully after discharging it completely and recharging a couple of times.



- If you charge a battery cartridge from a just-operated tool or a battery cartridge which has been left in a location exposed to direct sunlight or heat for a long time, the charging light may flash in red color. If this occurs, wait for a while. Charging will begin after the battery cartridge cools. The battery cartridge will cool faster if you remove the battery cartridge from the fast charger.
- If the charging light flashes alternately in green and red color a problem exists and charging is not possible. The terminals on the charger or battery cartridge are clogged with dust or the battery cartridge is worn out or damaged.
- If you wish to charge two battery cartridge, allow 15 minutes between charging on the fast charger.

**ASSEMBLY**

**Installing or removing driver bit or drill bit**

**CAUTION:**

Always be sure that the tool is switched off and the battery cartridge is removed before installing or removing the bit.

Hold the ring and turn the sleeve counterclockwise to open the chuck jaws. Place the bit in the chuck as far as it will go. Hold the ring firmly and turn the sleeve clockwise to tighten the chuck.

To remove the bit, hold the ring and turn the sleeve counterclockwise.

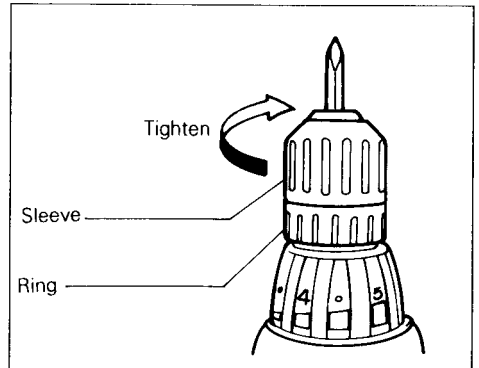

When not using the driver bit, keep it in the bit holders. Bits 45 mm (1-3/4") long can be kept there.

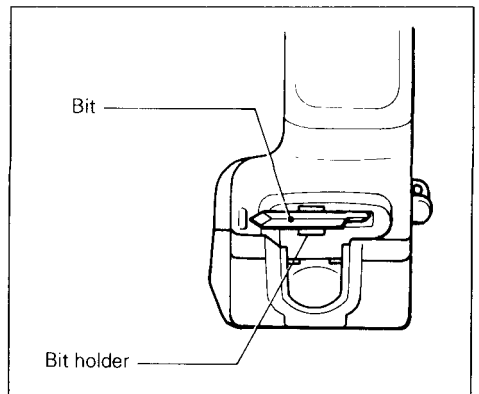

## OPERATION

### Switch action

#### CAUTION:

Before inserting the battery cartridge into the tool, always check to see that the switch trigger actuates properly and returns to the "OFF" position when released.

To start the tool, simply pull the trigger. Tool speed is increased by increasing pressure on the trigger. Release the trigger to stop.

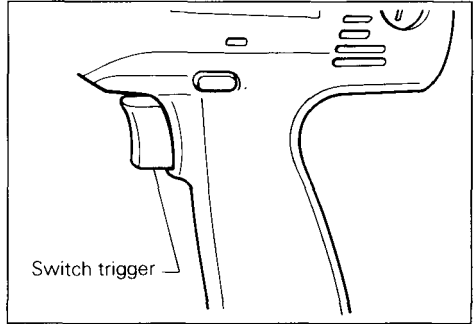

### Reversing switch action

#### CAUTION:

- Always check the direction of rotation before operation.
- Use the reversing switch only after the tool comes to a complete stop. Changing the direction of rotation before the tool stops may damage the tool.

This tool has a reversing switch to change the direction of rotation. Depress the reversing switch lever from the A side for clockwise rotation or from the B side for counterclockwise rotation. When the switch lever is in the neutral position, the switch trigger cannot be pulled.

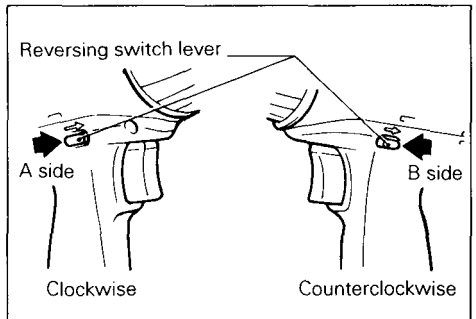

### Speed change

To change the speed, first switch off the tool and then slide the speed change lever to the "II" side for high speed or "I" side for low speed. Be sure that the speed change lever is set to the correct position before operation. Use the right speed for your job.

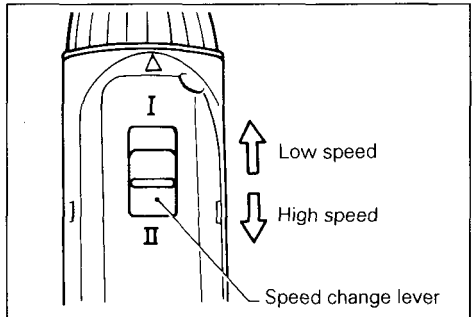

**CAUTION:**

- Always set the speed change lever fully to the correct position. If you operate the tool with the speed change lever positioned half-way between the "I" side and "II" side, the tool may be damaged.
- Do not use the speed change lever while the tool is running. The tool may be damaged.

**Adjusting the fastening torque**

The fastening torque can be adjusted in 18 steps by turning the adjusting ring so that its graduations are aligned with the pointer on the tool body. The fastening torque is minimum when the number 1 is aligned with the pointer, and maximum when the  $\frac{1}{2}$  marking is aligned with the pointer.

The clutch will slip at various torque levels when set at the number 1 to 5. The clutch is designed not to slip at the  $\frac{1}{2}$  marking.

Before actual operation, drive a trial screw into your material or a piece of duplicate material to determine which torque level is required for a particular application.

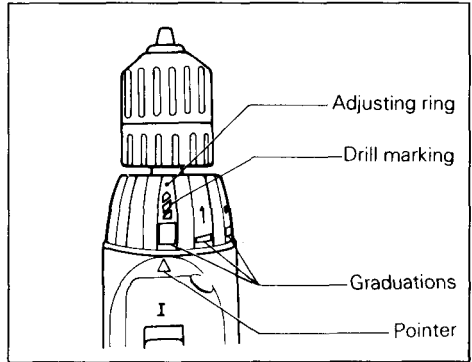

**NOTE:**

- The adjusting ring does not lock when the pointer is positioned only half-way between the graduations.
- Do not operate the tool with the adjusting ring set between the number 5 and the  $\frac{1}{2}$  marking. The tool may be damaged.

**Screwdriving operation**

Place the point of the driver bit in the screw head and apply pressure to the tool. Start the tool slowly and then increase the speed gradually. Release the trigger as soon as the clutch cuts in.

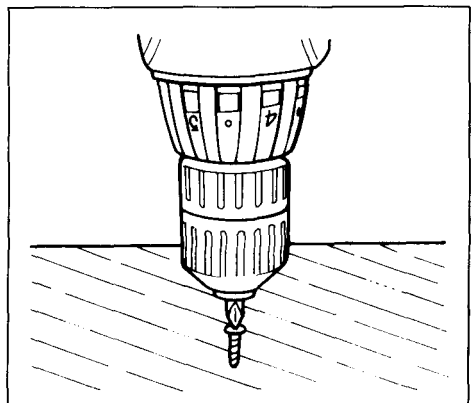

**NOTE:**

- Make sure that the driver bit is inserted straight in the screw head, or the screw and/or bit may be damaged.
- When driving wood screws, predrill pilot holes to make driving easier and to prevent splitting of the workpiece. See the chart.

Nominal diameter of wood screw (mm)	Recommended size of pilot hole (mm)
3.1 (1/8")	2.0 – 2.2 (5/64" – 3/32")
3.5 (9/64")	2.2 – 2.5 (3/32" – 3/32")
3.8 (5/32")	2.5 – 2.8 (3/32" – 7/64")
4.5 (11/64")	2.9 – 3.2 (7/64" – 1/8")
4.8 (3/16")	3.1 – 3.4 (1/8" – 9/64")
5.1 (13/64")	3.3 – 3.6 (1/8" – 9/64")
5.5 (7/32")	3.7 – 3.9 (9/64" – 5/32")
5.8 (7/32")	4.0 – 4.2 (5/32" – 11/64")
6.1 (15/64")	4.2 – 4.4 (11/64" – 11/64")

- If the tool is operated continuously until the battery cartridge has discharged, allow the tool to rest for 15 minutes before proceeding with a fresh battery.

**Drilling operation**

First, turn the adjusting ring so that the pointer on the tool body points to the  $\frac{8}{8}$  marking. Then proceed as follows.

- **Drilling in wood**  
When drilling in wood, best results are obtained with wood drills equipped with a guide screw. The guide screw makes drilling easier by pulling the bit into the workpiece.
- **Drilling in metal**  
To prevent the bit from slipping when starting a hole, make an indentation with a center-punch and hammer at the point to be drilled. Place the point of the bit in the indentation and start drilling.  
Use a cutting lubricant when drilling metals. The exceptions are iron and brass which should be drilled dry.

**CAUTION:**

- Pressing excessively on the tool will not speed up the drilling. In fact, this excessive pressure will only serve to damage the tip of your bit, decrease the tool performance and shorten the service life of the tool.
- There is a tremendous force exerted on the tool/bit at the time of hole breakthrough. Hold the tool firmly and exert care when the bit begins to break through the workpiece.
- A stuck bit can be removed simply by setting the reversing switch to reverse rotation in order to back out. However, the tool may back out abruptly if you do not hold it firmly.
- Always secure small workpieces in a vise or similar hold-down device.
- If the tool is operated continuously until the battery cartridge has discharged, allow the tool to rest for 15 minutes before proceeding with a fresh battery.

## MAINTENANCE

### CAUTION:

Always be sure that the tool is switched off and the battery cartridge is removed before attempting to perform inspection or maintenance.

### Replacing carbon brushes

Remove and check the carbon brushes regularly. Replace when they wear down to the limit mark. Keep the carbon brushes clean and free to slip in the holders. Both carbon brushes should be replaced at the same time. Use only identical carbon brushes.

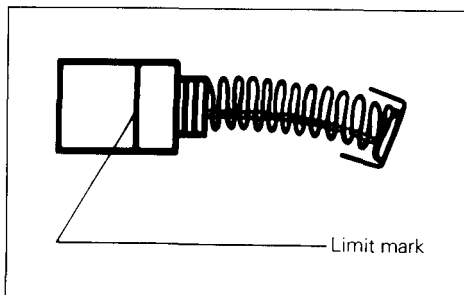

Use a screwdriver to remove the brush holder caps. Take out the worn carbon brushes, insert the new ones and secure the brush holder caps.

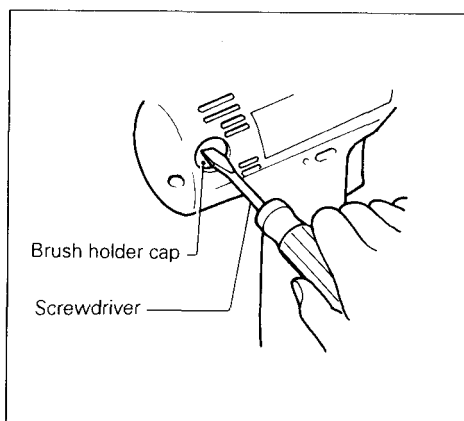

To maintain product SAFETY and RELIABILITY, repairs, maintenance or adjustment should be performed by Makita Authorized or Factory Service Centers, always using Makita replacement parts.

# ACCESSORIES

## CAUTION:

These accessories or attachments are recommended for use with your Makita tool specified in this manual. The use of any other accessories or attachments might present a risk of injury to persons. The accessories or attachments should be used only in the proper and intended manner.

### • Bits

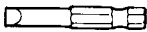
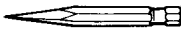
	Size	Part No.
	# 2	784214-0A
	# 3	784215-0A
	# 5F	784010-0A
	# 7F	784011-0A
		784606-0A

### • Phillips bit

Part No.	Size	L (mm)
784201-5	No. 1	65 (2-5/8")
784202-3	No. 2	45 (1-3/4")
784203-1		65 (2-5/8")
784206-5		110 (4-3/8")
784207-3		150 (5-7/8")

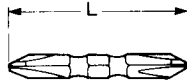

### • Drill bits

Tested best in Makita driver-drills for smooth fast drilling and more holes per battery change. High speed steel. For drilling in metal, wood and plastic. Jobbers length. Special surface treatment for lubricity gives smoother drilling.



Part No.	Drill dia.	Shank dia.	Flute length	Overall length
711011-A	1/16"	1/16"	7/8"	1-7/8"
711012-A	3/32"	3/32"	1-1/4"	2-1/4"
711013-A	1/8"	1/8"	1-5/8"	2-3/4"
711014-A	5/32"	5/32"	2"	3-1/8"
711015-A	3/16"	3/16"	2-5/16"	3-1/2"
711016-A	7/32"	7/32"	2-1/2"	3-3/4"
711017-A	1/4"	1/4"	2-3/4"	4"
711018-A	9/32"	9/32"	2-5/16"	4-1/4"
711019-A	5/16"	5/16"	3-3/16"	4-1/2"
711020-A	11/32"	11/32"	3-7/16"	4-3/4"
711021-A	3/8"	3/8"	3-5/8"	5"
711000-A-A	6 pc. set: 1/16", 1/8", 3/16", 1/4", 5/16", 3/8" Best selling bits in convenient case.			

### • Rubber pad assembly

Part No. 123001-2

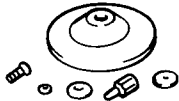

### • Foam polishing pad

Part No. 743023-2

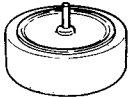

### • Double-ended Phillips / Slotted bit

1-3/4" long

Part No. 784637-8

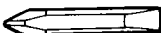

### • Wool bonnet

Part No. 743401-6



### • Fast charger

Model DC1410

Part No. 113150-3

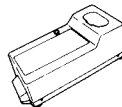

### • Battery cartridge 9122

Part No. 192596-6

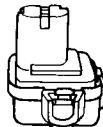

### • Battery cover

Part No. 414938-7



### • Plastic carrying case



# CORDLESS DRIVER DRILL

## Model 6203DWA

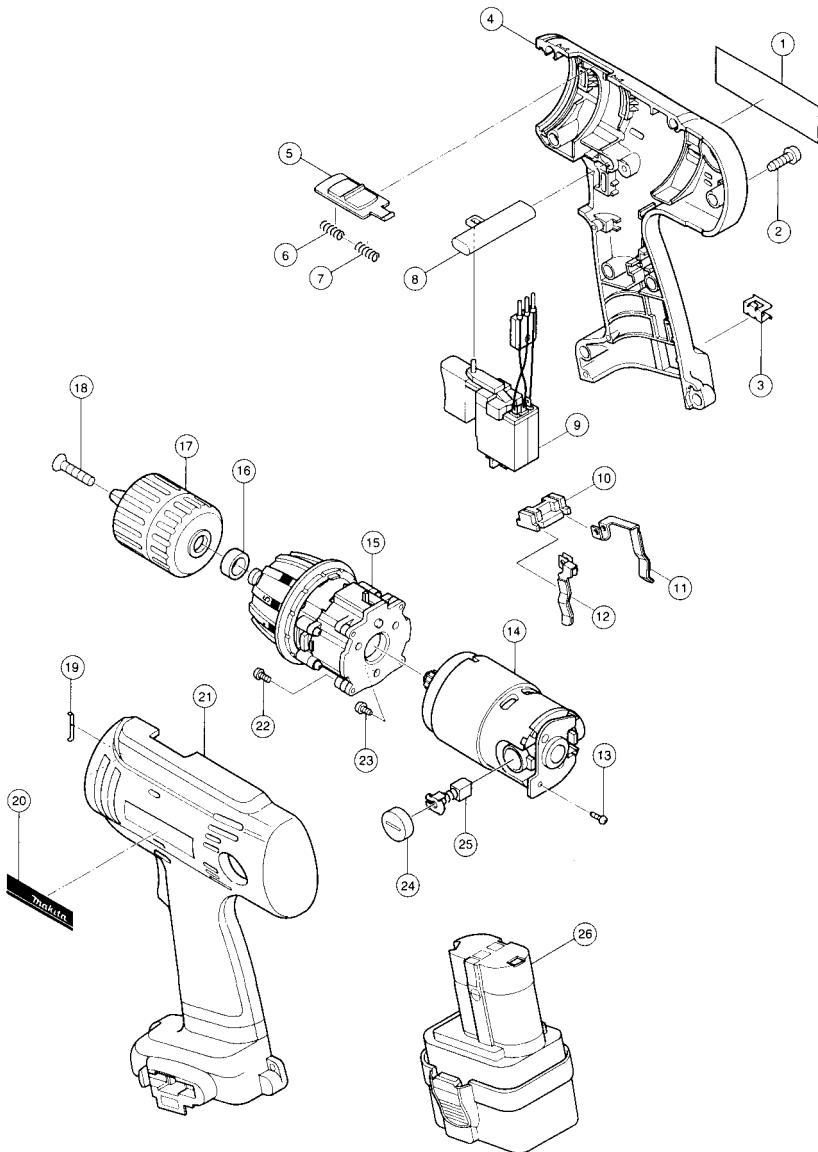

Note: The switch and other part configurations may differ from country to country.

ITEM NO.	NO. USED	DESCRIPTION	ITEM NO.	NO. USED	DESCRIPTION
<u>MACHINE</u>			<u>MACHINE</u>		
1	1	Name Plate	14	1	DC Motor
2	9	Tapping Screw Bind PT 3x16	15	1	GEAR ASSEMBLY
3	2	Bit Holder	16	1	Sleeve 10
4	1	Housing Set (With Item 21)	17	1	Keyless Drill Chuck 10
5	1	Change Lever	18	1	Hex. Socket Head Bolt M5x21
6	1	Compression Spring 4	19	1	Leaf Spring
7	1	Compression Spring 4	20	1	Makita Label
8	1	F/R Change Lever	21	1	Housing Set (With Item 4)
9	1	Switch	22	4	Pan Head Screw M3x12
10	1	Holder	23	3	Tapping Screw ST 4x8
11	1	Spring Terminal ( + )	24	2	Brush Holder Cap
12	1	Spring Terminal ( - )	25	2	Carbon Brush
13	1	Pan Head Screw M3x8	26	1	High Capacity Battery 9122

Note: The switch and other part specifications may differ from country to country.



## Recycling the Battery

The only way to dispose of a Makita battery is to recycle it. The law prohibits any other method of disposal.

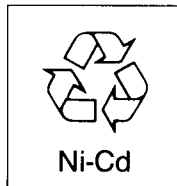

To recycle the battery:

1. Remove the battery from the tool.
2. a). Take the battery to your nearest Makita Factory Service Center  
or  
b). Take the battery to your nearest Makita Authorized Service Center or Distributor that has been designated as a Makita battery recycling location.
  - *Call your nearest Makita Service Center or Distributor to determine the location that provides Makita battery recycling. See your local Yellow Pages under "Tools-Electric".*

### MAKITA LIMITED ONE YEAR WARRANTY

#### Warranty Policy

Every Makita tool is thoroughly inspected and tested before leaving the factory. It is warranted to be free of defects from workmanship and materials for the period of ONE YEAR from the date of original purchase. Should any trouble develop during this one-year period, return the COMPLETE tool, freight prepaid, to one of Makita's Factory or Authorized Service Centers. If inspection shows the trouble is caused by defective workmanship or material, Makita will repair (or at our option, replace) without charge.

This Warranty does not apply where:

- repairs have been made or attempted by others;
- repairs are required because of normal wear and tear;
- The tool has been abused, misused or improperly maintained;
- alterations have been made to the tool.

IN NO EVENT SHALL MAKITA BE LIABLE FOR ANY INDIRECT, INCIDENTAL OR CONSEQUENTIAL DAMAGES FROM THE SALE OR USE OF THE PRODUCT. THIS DISCLAIMER APPLIES BOTH DURING AND AFTER THE TERM OF THIS WARRANTY.

MAKITA DISCLAIMS LIABILITY FOR ANY IMPLIED WARRANTIES, INCLUDING IMPLIED WARRANTIES OF "MERCHANTABILITY" AND "FITNESS FOR A SPECIFIC PURPOSE," AFTER THE ONE-YEAR TERM OF THIS WARRANTY.

This Warranty gives you specific legal rights, and you may also have other rights which vary from state to state. Some states do not allow the exclusion or limitation of incidental or consequential damages, so the above limitation or exclusion may not apply to you. Some states do not allow limitation on how long an implied warranty lasts, so the above limitation may not apply to you.

**Makita Corporation of America**

2650 Gainesville Hwy., Buford, GA 30518