

Microwellenherd

MICROMAT DUO 3214 Z

Microwave Oven

**Four à
micro-ondes**

**Cucina a
microonde**

Magnetronoven

Gebrauchsanweisung

Instructions for use

Mode d'emploi

Istruzioni per l'uso

Gebruiksaanwijzing

AEG

D	Gebrauchsanweisung	Seite	3
GB	Operating Instructions	page	20
F	Mode d'emploi	page	34
I	Istruzioni d'uso	pagina	48
NL B	Gebruiksaanwijzing	bladzijde	63

Das Gerät entspricht der EG-Richtlinie Nr. 76-889-EEC für Funkentstörung mit Ergänzungs-Richtlinie Nr. 82/499.

This appliance is in accordance with the EEC Guideline No. 76-889-EEC regarding radio interference and supplementary Guideline No. 82/449.

Cet appareil est conforme à la directive n° 76/889/EEC de la C.E.E. concernant l'anti-parasitage avec directive complémentaire n° 82/499.

Questo apparecchio corrisponde alla norma CE no. 76-889-CEE per schermatura contro i radiodisturbi integrativa con no. 82/499.

Dit apparaat voldoet aan EG-richtlijn no. 76-889-EEC voor storingvrij radio- en tv-verkeer met aanvullende richtlijn no. 82/499.

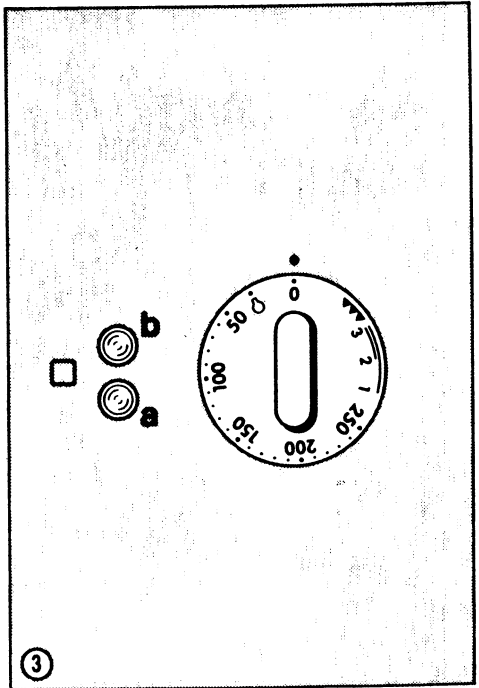
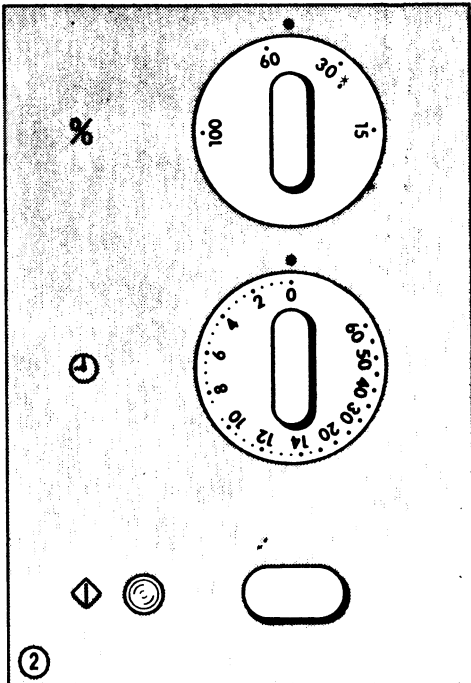
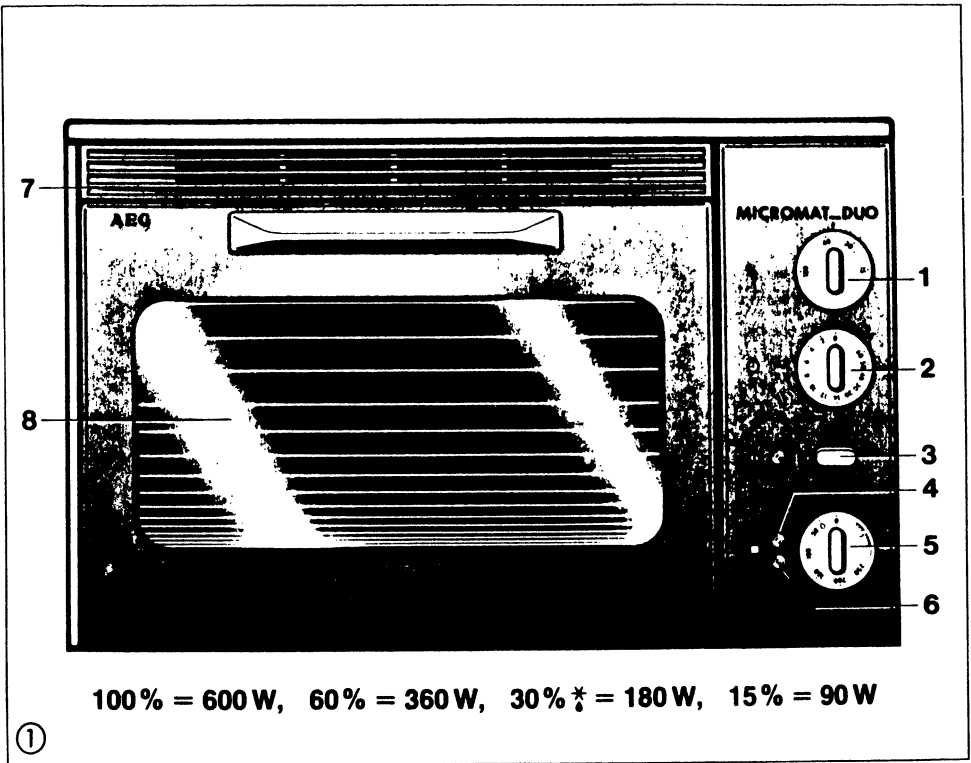

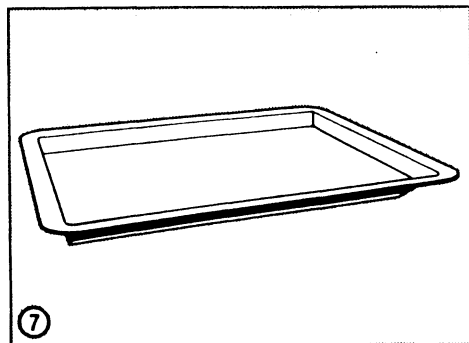
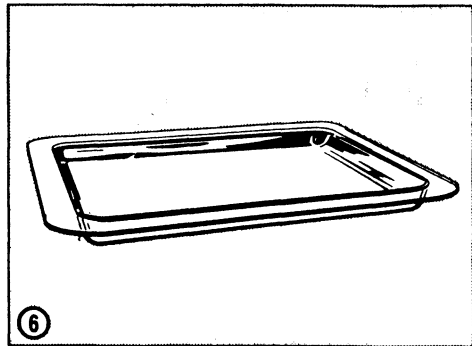
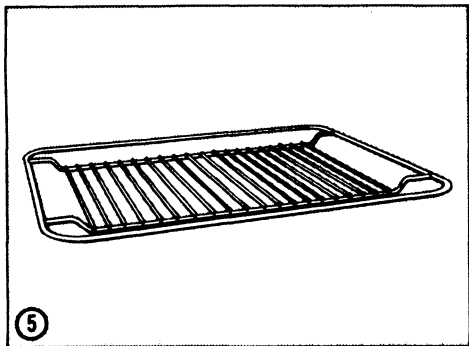
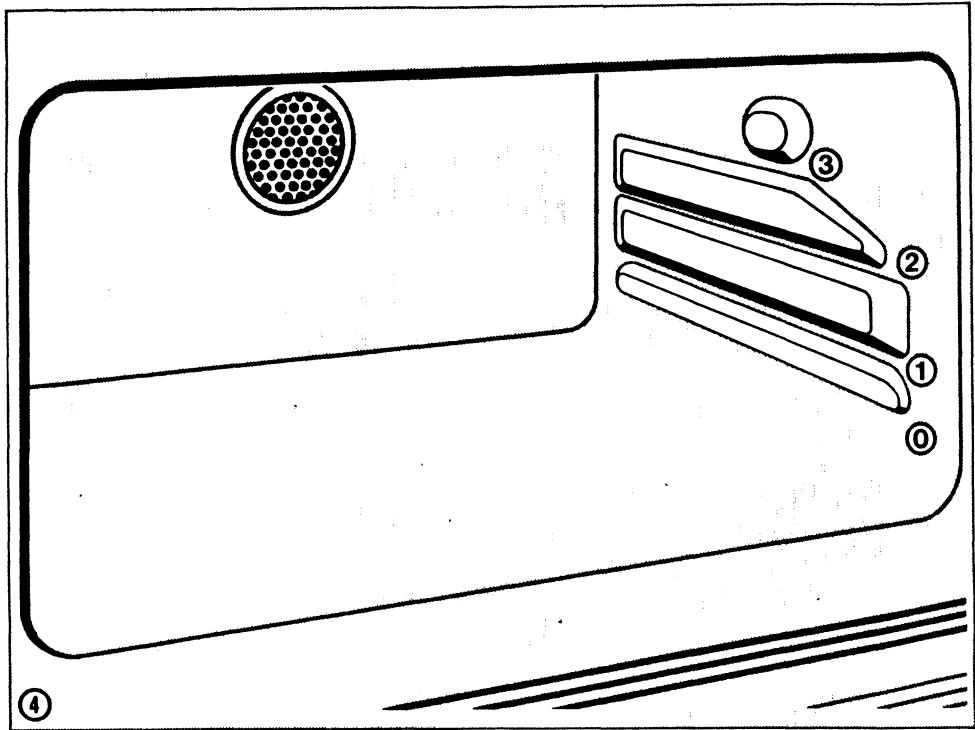

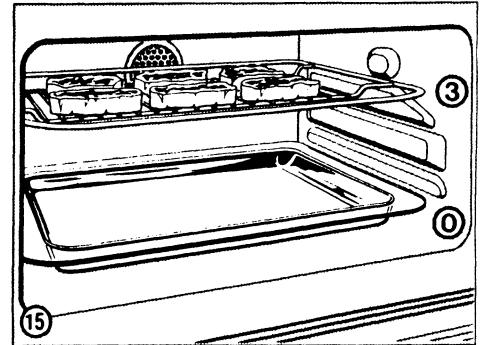
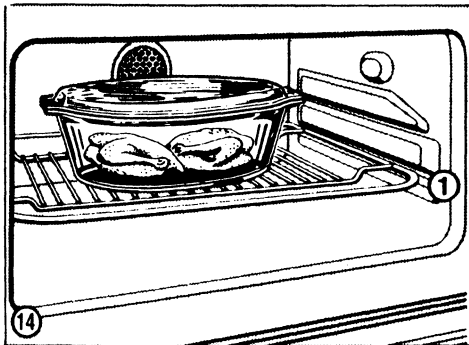
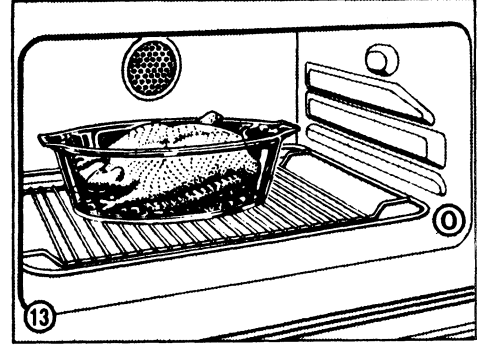
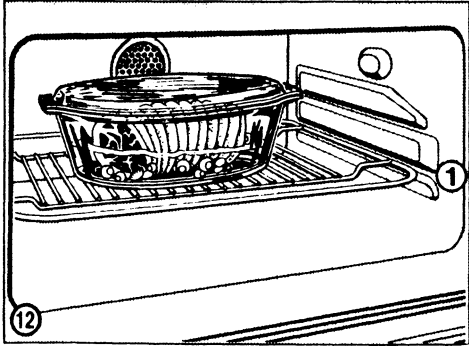
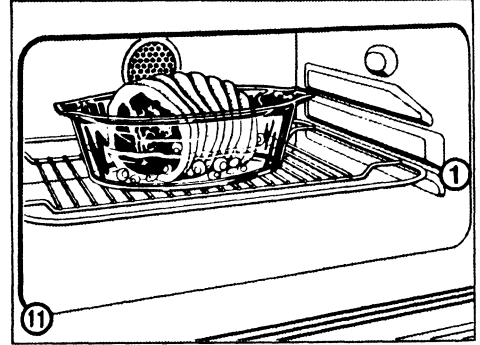
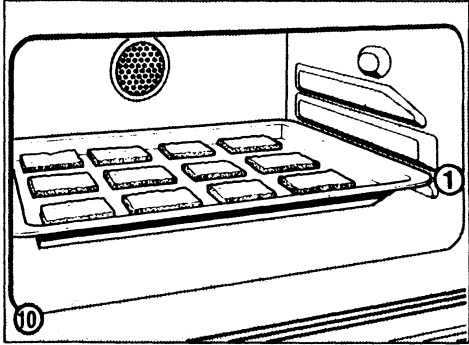
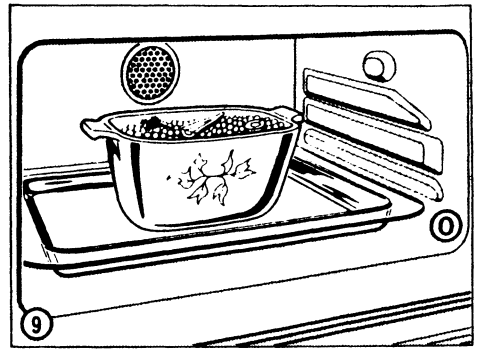
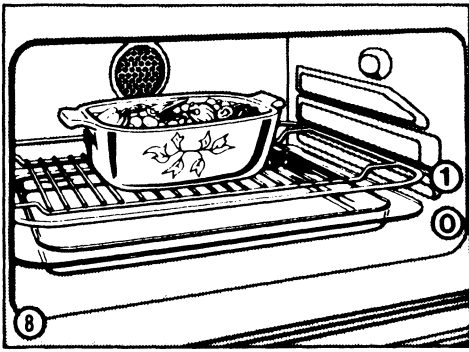

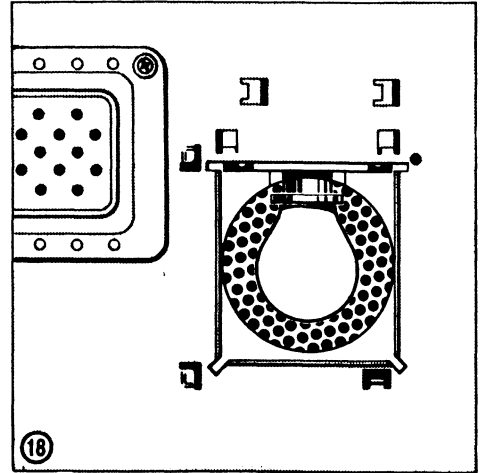
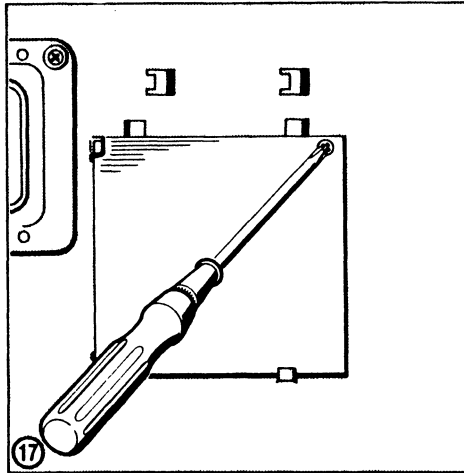
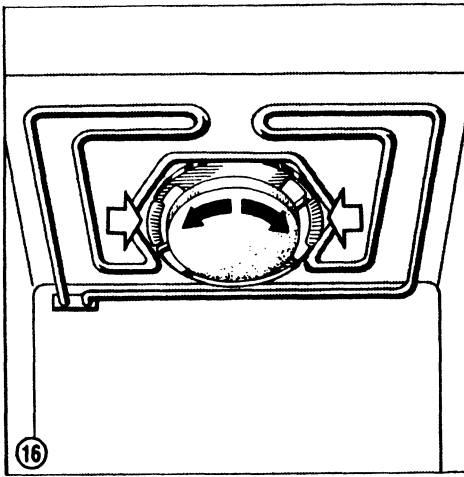

English

Contents

Description

- 21 Summary
- 21 Microwave
- 21 Temperature selector
- 21 Oven

How to use the oven

- 22 Microwave – general information
- 22 Cooking containers
- 22 **Safety instructions**
- 23 Microwave on its own
- 25 Baking
- 27 Baking with simultaneous use of microwave
- 27 Questions on baking
- 28 Roasting
- 29 Roasting with simultaneous use of microwave
- 30 Grilling thin pieces of food
- 31 Grill with simultaneous microwave
- 32 Care
- 33 Repairs/Changing the oven bulb/Faults
- 33 Customer service

Setting up and connecting

Put the oven on a stable, even base. The ventilation openings at the back and at the bottom of the appliance should not be covered.

The appliance may only be connected to a properly installed earthed socket and must have a 16 Amp fuse (L-Type) or 13 Amp in Great-Britain. The mains voltage must be the same as that on the label of the appliance. Use a good quality plug and socket. (Do not use an adapter.)

Before reading these instructions, please open the folded back page with illustrations

What you must know about the use of your appliance

- The surface of heating and cooking appliances become hot in operation, so take care and keep small children away.
- Keep electric leads of other electrical appliances which may be plugged in near the oven, away from any part of the oven.

What you must know in particular about working with microwaves

Since your new stove is also a microwave appliance, you must also observe instructions applicable for microwave appliances.

- Switch on the microwave only when there is food in the oven, otherwise the appliance can become overheated.
- The oven door must be closed tightly during microwave operation. Therefore, please keep door frame clean from any food particles etc.
- If the door becomes damaged, i.e. through glass breakage, contact customer service and do not use the oven until it has been repaired by a customer service agent.
- For safety, nothing may be stored in the oven, which in case of unintended switching on could cause danger for the surroundings.
- Occasionally, condensation will appear on the door window, on the inside walls and on the base of the oven. This is normal and does not affect operation. Wipe off condensation after cooking is completed.

In the usage section, we have compiled important safety instructions for cooking with microwave, which you must observe without fail.

Description and operation

Temperature selector ③

Summary ①

- 1 Power selector for microwave
- 2 Time switch for microwave
- 3 Starter button for microwave with green control lamp
- 4 Temperature control lamp (red) for oven
- 5 Temperature selector for oven
- 6 Pilot lamp (yellow) for oven
- 7 Ventilating grating
- 8 Oven door with window

Details may vary depending on the particular type of oven

Operating the microwave ②

Set the required microwave power with the **power selector**.

Set the length of the cooking time (up to 60 minutes) with the **time switch**.

If a cooking time of less than 2 minutes is required, turn the selector to a longer time, then turn back to the shorter period.

Before starting, the oven door must be closed.

To start, simply press the starting button.

The green control lamp and the oven lamp light up. The microwave is now operating.

The microwave stops operating automatically as soon as the door is opened. The timer also stops and in order to continue cooking after the door has been re-closed, the starter button has to be pressed again. Operation will then continue.

At the end of select cooking time, a signal will sound. The microwave operation stops and the green control lamp and the oven lamp are switched off.

Microwave power (max. 600 W)

- 100%: for heating up and cooking most foods
- 60%: for cooking meat particularly and for warming up sensitive foods
- 30%: for thawing and simmering
- 15%: for thawing sensitive foods

Sets oven temperature and grill.

 = oven lamp

50–250 = continuous temperature selection (°C)

 **3** = grill strong
2 = grill medium
1 = grill weak

a yellow indicator for operation

b red indicator lights up until the set temperature has been reached

During grilling, the lamp does not light up.

Before using the oven for the first time:

Heat up the empty closed oven for 60 minutes with the temperature selector set to 250.

For this, do **not** switch on the microwave!

Because of the developing odour, ventilate the kitchen.

The oven ④

The oven can be used as follows:

- Microwave only for defrosting warming up and cooking
- Conventional heating only for baking, roasting and grilling
- Conventional heating with simultaneous microwave for fast baking, roasting and grilling – integrated operations

Accessories

Food can be cooked at 4 different levels.

Level **0** = Oven base

Levels **1–3** = Shelf positions

⑤ Grid

⑥ Glass oven tray

⑦ Baking tray

Tips for the oven

- Do not line oven with aluminium foil as this may cause heat to build up in such a way that it alters baking and roasting results. It can also damage the enamelling.
- You can keep your oven clean if you use tall vessels or those provided with a lid.

● For built-in appliances:

To avoid soiling of furniture lying above the appliance, the enclosed grill screen can be attached.

A further possibility of avoiding soiling of the furniture:

Let the fan continue in operation for another 10 minutes, if hot dishes remain in the appliance to finish cooking. Set the temperature selector to 50 for this.

How to use the oven

The following briefly explains the many possibilities of the oven.

You will find detailed recipes and tips in our cookery book.

Microwave

This is a completely new way of cooking: The microwave generates heat in the food which is being cooked. This means that the cooking process is quick, gentle and saves energy.

What utensils are suitable for microwave applications?

- Cooking containers must allow the microwaves to pass through them. Containers made of glass, porcelain, earthenware and clay as well as heatproof plastic are suitable. Do not use metal containers.
- Metal deflects microwaves. Therefore, food in closed metal containers cannot become warm. However, it is possible to heat a ready-to-serve meal in its open aluminium foil dish on the glass oven tray.
- Please ensure that metal objects do not come into contact with the oven walls as this may cause arcing.

- Many vessels are not suitable for microwave cooking. If you want to test your vessel, place it empty for around 20 seconds in the appliance at the highest setting. If the vessel remains cold or becomes only lukewarm, it is suitable; if it becomes very hot, however, or sparks develop, it is unsuitable.
- Do not use dishes with gold or silver decorations, as these can be damaged by microwaves.
- Heated foods transmit heat to the vessel. It can therefore become very hot. Always use pot holders for this reason.
- In many cases, serving dishes can be used for cooking in a microwave. This saves washing up.

Safety instructions

- Before heating up liquids, always put a coffee spoon into the vessel!

This will avoid the "boiling delay".

Boiling delay develops, when the boiling temperature has been reached, but the typical vapour bubbles do not yet rise. When the vessel is removed, the liquid can boil over violently due to shaking or even spatter.

Danger of burns!

- Alcoholic beverages may not be heated too hot. For this reason, set the required time and observe the situation.
- Do not cook any eggs in the shell. They can burst in the oven or after removal.
Do not warm up hard-boiled eggs. They will become hot faster in the middle than in the edge sections and can burst.
You can prepare scrambled eggs at any time; for fried eggs, it is important to pierce the yolk beforehand.
- After warming babyfood in glasses or bottles, you should stir or shake the contents so that the heat will be evenly distributed. Before you give the child its food, please check the temperature.
- For foods with firm shells or skins (e.g. apples, tomatoes, potatoes, sausages), the skin can burst. They must be pierced before warming.

Microwave on its own ⑧ ⑨

Using the microwave facility on its own gives you a great number of possibilities to cook. We have compiled a selection in the following charts. Many more details are given in our cookery book.

If your quantities differ from those in the charts, use the following as a rough guide:

Double quantity – double the time given

Half quantity – half the time given

Please note:

When a cooking time of less than 2 minutes is selected the switch should be turned to a longer time and then turned back to the shorter period.

Where ranges are given, always set the shorter period or the lower temperature first.

Put the food in a suitable container, place it on the grid  at shelf level 1 and additional the glass oven tray at shelf level 0 ⑧.

Note: If the dish is exceptionally tall use only the glass oven tray at shelf level 0 ⑨.

Heating ready-to-serve dishes

	Quantity	Microwave	
		Power	Time
Soups Stews Baked puddings Meat and poultry dishes Side dishes Vegetables Beverages	100 g	100 %	1 to 2 min.
	250 g	100 %	3 to 4 min.
	500 g	100 %	5 to 6 min.
	1000 g	100 %	10 to 12 min.
	Meal, on a plate	1 portion	100 %

If dishes are stirred or turned during heating, the food will heat up faster and more uniformly.

Defrosting and heating ready-to-serve dishes

	Quantity	Microwave	
		Power	Time
Ready to serve dishes Meal on a plate	250 g	100 %	5 to 7 min.
	500 g	100 %	11 to 14 min.

The food gets hotter the longer it is in the oven.

Warming up and melting foods

Quantity	Microwave	
	Power	Time

Warming-up milk	60 g	100 %	30 secs
	120 g	100 %	45 secs
	180 g	100 %	1 min.
Warming-up baby food in bottles (refrigerator temperature)	200 g	60 %	2 min.
Softening butter from a refrigerator	250 g	30 %	30 secs
Melting butter	50 g	100 %	30 secs
Melting honey	250 g	15 %	8 to 10 min.
Melting chocolate for cake coverings	150 g	100 %	1 min.

Cooking small amounts and delicate dishes

Fresh vegetables	250 g	100 %	7 to 10 min.*
Fresh mushrooms	250 g	100 %	3 to 4 min.*
Frozen vegetables	300 g	100 %	8 to 15 min.*
Fresh fish	200 g	100 %	4 min.
	400 g	100 %	7 min.
Frozen fish	200 g	100 %	7 min.
	400 g	100 %	12 min.
Rice	125 g	100 %	5 min.
		+ 30 %	15 min.
Pudding/blancmange	0.5 l	100 %	5 min.

* depending on type

Special roasts

Minced meat loaf	700 g	100 %	17 min.
------------------	-------	-------	---------

Defrosting

Quantity	Mikrowave Power / Time	Rest time	Total-time
----------	------------------------	-----------	------------

1 chicken	1000 g	30 % / 22 min.	10 min.	32 min.
2 chickens	à 1000 g	30 % / 30 min. + 15 % / 20 min.	10 min.	1 h
1 duck	2000 g	30 % / 40 min. + 15 % / 20 min.	10 min.	1 h 10 min.

turn half way through defrosting time

turn large chickens, turkeys etc. several times during defrosting

Defrosting

	Quantity	Mikrowave Power / Time	Rest time	Total-time
Meat (compact portions)	500 g	15 % / 30 min.	10 min.	40 min.
	1000 g	30 % / 20 min. + 15 % / 25 min.	10 min.	55 min.
	1500 g	30 % / 30 min. + 15 % / 25 min.	15 min.	1 h 10 min.
Minced meat	500 g	30 % / 10 min. + 15 % / 15 min.	10 min.	35 min.

Turn meat half way through defrosting time. Turn pieces weighing more than 1 kg several times. Turn minced meat once, then break up with a fork.

Fish**	500 g	15 % / 20 min.	10 min.	30 min.
	1000 g	30 % / 15 min. + 15 % / 20 min.	20 min.	55 min.
Butter*	250 g	15 % / 10 min.	–	10 min.
Bread*	500 g	30 % / 7 min.	5 min.	12 min.
	1000 g	30 % / 15 min.	10 min.	25 min.
Rolls*	4 rolls	15 % / 4 min.	5 min.	9 min.
Berries/stone fruit	250 g	30 % / 8 min.	5 min.	13 min.
	500 g	30 % / 13 min.	5 min.	18 min.

* turn once

** turn several times

Baking ⑩

Unless otherwise instructed, put all cakes and pastries into the **cold oven**. This saves energy.

Push baking sheets – with bevel towards the oven door – right into the oven up to the stop.

Cakes with fresh fruit toppings (i.e. plums, apples, cherries etc.) are best baked on the **glass oven tray** supplied.

Non-stick tins are particularly suitable for baking. Always place cake tins in the **centre** of the grid.

When baking for the first time use the lower given temperature and set it higher the next time if necessary. This is how you can determine yourself the individual browning you desire.

We have compiled the most important data for baking in the following tables.







All data is a guide only and may vary depending on taste, recipe and baking utensils used. Generally, lower temperatures produce a more uniform browning.

All data applies to cakes being put into the **cold oven**.

If the oven has been preheated, shorten baking times by 5 to 10 minutes.

Cakes in tins

Shelf level	Accessory	Oven-temperature	Time
-------------	-----------	------------------	------

Plain cakes	0	Grid 	160–180°C	70– 80 min.
Madeira and fruit-cake	0	Grid 	160–180°C	75– 85 min.
Cashing for fresh fruit cakes	1	Grid 	190–210°C	25– 35 min.
Cheesecake	0	Grid 	160–180°C	90–100 min.
Ready mixed cakes	0	Grid 	160–180°C	60– 70 min.
Sponge cakes	0	Grid 	180–200°C	30– 45 min.
Deep-frozen ready-to-bake cakes e.g. apple, poppyseed, cheesecake	0	Grid 	as indicated on package	

Cakes on baking sheets

Shelf level 1

Oventemperature	Time
-----------------	------

Fairy cakes*	150–170°C	20–25 min.
Scones*	210–230°C	10–15 min.
Swiss roll	190–210°C	10 min.
Apple pie	190–210°C	30–35 min.
Bread	200–220°C	40–50 min.
Pizza**	210–230°C	30–45 min.

* Pre-heating is necessary

** or on the glass oven tray, shelf level 2

Biscuits on baking sheets

Shelf level 1

Oventemperature	Time
-----------------	------

Cookies	170–190°C	1st sheet	20–25 min.
		additional sheets	10–15 min.
Shortbread	170–190°C	1st sheet	25–30 min.
		additional sheets	10–15 min.
Meringue	80–100°C	120–150 min.	
Puff pastry	200–220°C	20–30 min.	
Choux pastry	200–220°C	25–35 min.	
Macaroons/cinnamon stars	160–180°C	20–30 min.	
Small cakes made from yeast dough, e.g. Chelsea buns	190–210°C	20–30 min.	

Where ranges are given, always set the shorter period or the lower temperature first.

Baking with simultaneous use of microwave

Shelf level	Accessory	Oven-temperature	Microwave	
			Power	Time



Deep-frozen ready-to-bake cakes

Apple pie	1	Glass oven tray	230°C	30 %	20 min.
-----------	---	-----------------	-------	------	---------

Ready mixed cakes¹⁾

Plain cakes	0	Grid 	190°C	30 %	20 min.
-------------	---	--	-------	------	---------

Cakes with moist toppings in container¹⁾

Cherry cake ²⁾	1	Grid 	190°C	30 %	30 min.
Cheese cake	0	Grid 	180°C	30 %	25 min.

¹⁾ Bake cakes in containers made of glass, ceramic or heat resistant plastic

²⁾ Pre-heat for 10 min.

Questions on baking

How can I bake according to my own recipe?	Refer to the information given for similar pastry.
Why did the cake collapse ?	Next time use less liquid or set oven temperature 10 degrees lower. Possibly check the times of stirring mentioned in the cookery book.
Why did my cake rise nicely at the edges and collapse in the middle ?	Do not grease the edges of the cake tin. After baking carefully ease the cake out using a sharp knife.
Cake gets too dark on top.	Shove in at a lower shelf level, select lower oven temperature and bake a bit longer, use black baking tin.
Cake gets too dark on bottom.	Shove in at a higher shelf level, select lower oven temperature.
Fruit cake is too light on the bottom, fruit juice runs over.	Use the glass oven tray.
Why did my cake become too dry ?	Next time select temperature appr. 10 degrees higher and reduce baking time. Use toothpicks to prick little holes in the cake. Sprinkle fruit juice or alcoholic beverage on it.

Questions on baking

<p>How can I find out if my cake is properly baked inside?</p>	<p>Prick into the highest point of the cake with a wooden stick 10 minutes before the end of the baking time stated. If it is dry and there is no batter on it when you remove it, the oven can be switched off and the remaining heat used to finish baking the cake.</p>
<p>The bread or the cake (e.g. cheese cake) looks very nice, but when cutting it, it is still soggy inside.</p>	<p>Next time use less liquid and bake somewhat longer at a lower temperature. As far as cakes with moist covering are concerned, bake the bottom first and distribute ground almonds or bread crumbs on it before adding the covering. Please check recipe and baking times.</p>
<p>What can I do if my soufflé got much too dark on top?</p>	<p>Remove the crust and for a short time brown the soufflé under the grill. Do not use parmesan cheese – it browns too quickly and is quick to taste bitter. Next time place the shelf one level lower and/or reduce the temperature by 10 degrees.</p>
<p>The cookies do not come off the shelf.</p>	<p>Place the shelf in the oven once more for a short time and then immediately remove the cookies from the shelf.</p>
<p>The cake does not come off the tin when turning it.</p>	<p>Carefully try to ease the cake out again using a sharp knife. Turn the tin again and several times cover it with a wet, cold cloth. Next time grease the tin well and, in addition, line it with bread crumbs.</p>

Roasting ⑪ ⑫

Put all roasts into the **cold** oven. This saves energy.

You can get a perfect juicy roast as follows:

- in an open high sided dish on the grid
- in a roasting dish with a lid, on the grid

The roast stays juicier if you cook it in the roasting dish with the lid on. **The oven becomes less soiled.**

In this case select temperatures around 10–20 °C higher. The other settings do not change.

The following charts apply to roasts in an open dish, placed into the **cold oven**.

Length of roasting time and temperature depend on the kind of meat, the weight of the joint and its

texture, **the data given is to be used as a guide only.**

The length of roasting time does not alter substantially if you roast two pieces of meat, both of the same size, together.

You can roast **frozen joints** without prior defrosting. Select a temperature which is 10–20 °C lower than that given and lengthen the roasting time by the half.

Turn the oven off 10 minutes before the end of the roasting time and leave the meat inside and the door shut. This saves energy.

Turn the joint once, half-way during the roasting time.

Use grid with a roasting dish. If using the microwave setting ensure that the roasting dish is suitable.

Roasting without microwave

Weight	Shelf level	Oven-temperature	Roasting time
--------	-------------	------------------	---------------

Pork	1.0 kg	1	220°C	1 hr 30 min.
	1.5 kg	1	210°C	2 hrs
	2.0 kg	1	200°C	2 hrs 30 min.
Beef	1.0 kg	1	220°C	1 hr 30 min.
	1.5 kg	1	200°C	2 hrs
	2.0 kg	1	180–200°C	2 hrs 30 min.
Veal	1.0 kg	1	220°C	1 hr 30 min.
	1.5 kg	1	200°C	2 hrs
Poultry	1.0 kg	1	220°C	1 hr
	1.5 kg	1	200°C	1 hr 30 min.
	2.0 kg	1	180–190°C	2 hrs
Game	1.5 kg	1	200°C	1 hr 30 min.
Fish	1.0 kg	1	210°C	50 min.

Roasting with simultaneous use of microwave

Weight	Shelf level	Oven-temp.	Microwave		Additional without microwave	Total time
			Power	Time		

Pork	1.0 kg	1	210°C	30%	60 min.	–	60 min.	
	1.5 kg	1	200°C	30%	60 min.	20 min.	1 hr 20 min.	
	2.0 kg	1	190°C	30%	60 min.	30 min.	1 hr 30 min.	
1 leg of pork	1.0 kg	1	210°C	30%	45 min.	35 min.	1 hr 20 min.	
2 legs of pork	ea	1.0 kg	1	210°C	30%	45 min.	45 min.	1 hr 30 min.
Beef	1.0 kg	1	200°C	30%	60 min.	10 min.	1 hr 10 min.	
	1.5 kg	1	190°C	30%	60 min.	30 min.	1 hr 30 min.	
	2.0 kg	1	180°C	30%	60 min.	40 min.	1 hr 40 min.	
Veal	1.0 kg	1	200°C	30%	50 min.	10 min.	60 min.	
	1.5 kg	1	190°C	30%	60 min.	20 min.	1 hr 20 min.	
	2.0 kg	1	180°C	30%	60 min.	30 min.	1 hr 30 min.	

Use grid with a roasting dish suitable for microwave.

Turn all roasts after 30 minutes. When roasting pork the crackling should be face down at the start.

When roasting lean meats, add 2 to 3 tablespoons of water (wine).

At the end of the total time, leave the roast for another 10 minutes in the turned off oven with the door closed.

If you use a container with a lid, e.g. glass dish, **the oven will get less dirty**. Select temperatures around 10–20°C higher. The other settings do not change.

Roasting with simultaneous use of microwave (13)

	Weight	Shelf level	Oven-temp.	Side	Microwave		Total time
					Time	Power	
1 chicken	1 kg	0	230°C	1st 2nd	25 min. 20 min.	30%	45 min.
2 chickens	1 kg ea	0	230°C	1st 2nd	25 min. 20 min.	30%	45 min.
1 duck	1.5 kg	0	200°C 220°C	1st 2nd	40 min. 40 min.	30%	80 min.



Cooking dish: Grid with glass oven tray underneath

Place poultry, breast down, on the grid. Pour a cup of water into the glass oven tray. During the roasting period, baste frequently with water. This will make a good stock for gravy.

A nice browning is achieved by brushing poultry once during the first and second roasting periods.

By the way: (14)

This is how you can prepare a roast chicken especially fast without soiling the oven:

- Cut the chicken in halves and season.
- Place the halves with the skin side up in a heat-resistant vessel with glass lid.
- Insert grate  with vessel at level 1.
- Set temperature selector at  grillstage 3.
- Switch on microwave power stage 100% for around 17 minutes.

The chicken will then be juicy and crisp.

Note: Dish and lid become very hot. Do not

place on a cold or wet base, but preferably on a dry kitchen towel.

Grilling thin pieces of food (15)

Grill with oven door closed and without preheating. This ensures low energy consumption.

The pieces to be grilled should be of the same thickness (at least 2 to 3 cms). They will then be evenly cooked.

Always place the glass oven tray supplied at shelf level 0.

Pieces of meat up to 3 cms thick should be placed on the grid and then placed on shelf level 3. Delicate foods (fish) should be grilled at shelf level 2.







Set oven temperature selector to  grillstage 3.

The grid can be used in two ways; either with the curvature facing up or down.

When attending to the food use the glass oven tray to catch any drips.

Guide to grilling times

Grillstage 3

	Shelf level	Accessories	Side	Time
Steak, well-done	3	Grid 	1st side 2nd side	14 min. 10 min.
Steak, rare	3	Grid 	1st side 2nd side	10 min. 8 min.
Trout 300 g each	1	Grid 	1st side 2nd side	15 min. 5 min.
Sausages	3	Grid 	1st side 2nd side	9 min. 5 min.
Slices of fish	2	Grid 	1st side 2nd side	9 min. 6 min.
Toast	3	Grid 	1st side 2nd side	5 min. 2 min.

For best grilling results of an individual item, place the latter left or right to the middle of the grid, underneath the grill heating element.

Although pork, veal, poultry, fish etc. are often only lightly browned under the grill, they are nevertheless cooked through and retain their juices.

Practical tips:









Dark meat – e.g. beef, game and lamb – browns more quickly than light meat such as veal, pork and poultry.

Also important:



After longer grilling, the grill will turn itself on and off automatically for short periods.

Grill with simultaneous microwave

Use heat-resistant ovenware suitable for microwave

	Insertion level	Accessories	Grill stage	Microwave	
				Output	Length
Gratinated noodles	1	Glass oven tray	2	100 %	17 min.
Cottage cheese soufflé	0	grate 	1	100 %	14 min.
Cauliflowercheese	0	grate 	3	100 %	10 min.
Gratinated potatoes					
500 g potatoes	1	grate 	2	100 %	14 min.
1000 g potatoes	1	grate 	1	100 %	25 min.
Stuffed aubergines	1	grate 	1	100 %	12 min.
Leg of lamb without bones around 1200 g	0	grate 	1	30 %	1st side 35 min. 2nd side 25 min.
Spare ribs around 800 g	1	grate 	1	30 %	1st side 28 min. 2nd side 8 min.
Roast beef around 1000 g	2	grate 	1	30 %	1st side 18 min. 2nd side 12 min.

Deep-frozen food

Gourmet's fillet	1	Glass oven tray or high sided dish on grate 	2	100 %	12 min.
Steaklets	2	grate 	2	100 %	1st side 8 min. 2nd side 5 min.
Cannelloni	0	grate 	1	100 %	12 min.

Care

Appliance outside

Wipe with damp cloth only. Do not use any sharp or scouring cleaning agents. Use special cleaning agents only according to manufacturer's instructions.

For appliances with white housing, the venting screen can be removed when the door is open and cleaned. When you replace it, be sure that the notches face upward.

Oven

The oven light  can be switched on with the temperature selector for cleaning. Wipe out oven with hot detergent suds.

Do not use hard scouring pads.

If the oven is very dirty, use commercial oven cleaners (sprays, etc.) e.g. K2r.

Spray the **cold** oven with it, let it act for a few minutes and then wipe off.

If grease or food residues are heavily burnt into the oven, spray oven cleaner into the cold oven, set to 50 °C and heat up for no more than 2 minutes.

A longer heating-up time than **2 minutes** produces higher temperatures; the cleaning agent can **become aggressive** as a result. This can cause spots to appear on the enamel.

Use oven cleaning agents (spray, etc.) only on the enamelled surfaces of the oven. If any oven cleaner is inadvertently sprayed on painted or plastic elements (i.e. control panel, switch handle, door handle, etc.), it must be washed off immediately, otherwise dull spots will develop.

Fruit juices contain acids. Dripping juices can leave spots on the oven floor which cannot longer be removed. Therefore, do not overload the tins when you bake very moist fruit cakes, or even better, use the glass tray supplied.

The **grill element** cannot be removed for cleaning.

The oven ceiling is coated with selfcleaning catalytic enamel.

Cleaning the glass cover on the oven ceiling

16
To clean, turn the glass cover out of the catch and remove. If only slightly soiled, clean it with

detergent, and if heavily soiled with the green side of Scotch-Britt.

When reinserting, turn the cover, until it is correctly engaged.

The **frame** on the inside of the door is made of stainless steel. Because of the high baking and roasting temperatures, the stainless steel takes on a brownish discolouration. This does not affect its quality.

You can eliminate slight soiling of the frame with a moist cloth and stainless steel or glass ceramic cleaning agents (e.g. "Hui Stahl-Blank", "Collo profi").

In case of greater soil, we recommend use of a moistened cleaning sponge, e.g. Scotch-Britt, green side (but not for the glass pane). In each case, observe the instructions for these cleaning agents.

Cleaning microwave accessories

The best results are obtained by soaking the accessories immediately after use in washing up water, then remove any dirt with a sponge or brush.

The grid can be cleaned with a stainless steel cleaning agent. The grid and the glass oven tray can also be cleaned in a dishwasher.

Do not clean the glass oven tray with scouring agents.

Repairs

This product meets the pertinent safety provisions for electrical appliances.

Repairs to the oven may only be carried out by a trained technician. However, the bulb for the oven light can easily be changed by yourself.

Heat resistant special replacement bulbs can be obtained from customer service.

Caution

Before changing the bulb ensure that the appliance is disconnected from the mains by pulling out the plug.

1. Unscrew coverplate at the back of the appliance **17**.
2. Replace bulb **18**.
3. Replace cover plate.

363 310

H 261 256 600-0788-

Änderungen vorbehalten
Subject to change without notice
Sous réserve de modifications
Riservato il diritto di effettuare modifiche
Wijzigingen voorbehouden
Reservado el derecho de modificación

AEG