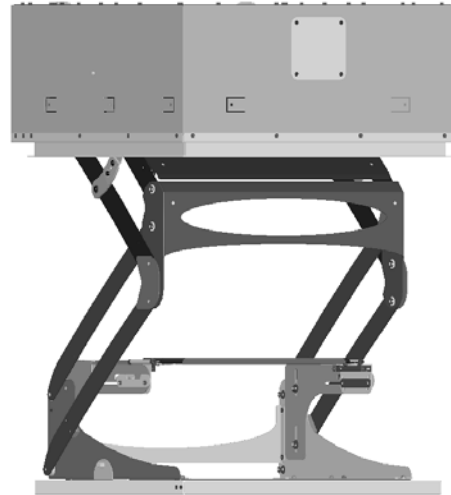

INSTALLATION INSTRUCTIONS

SMART-LIFT™ 236 Electric Ceiling Lift

The Model SL-236 Electric Ceiling Lift is a reliable, heavy-duty video lift mechanism for LCD/DLP projectors requiring an extended drop from their hidden location. The ceiling lift is designed for home-theater, conference room, or school applications.

The SL-236 provides an attractive solution to recess a projector in the ceiling. The lift is suitable for finished or suspended ceiling with a finish kit. The concealed bottom can be finished to match existing ceiling design and color to conform to room decor.

Plenum Rating requires use of Class II control wiring, electrically hard wiring the unit, and all open holes in the housing (except joist tabs) must be sealed using foil tape.



BEFORE YOU BEGIN

- **CAUTION:** To prevent damage to the ceiling lift, which could affect or void the factory warranty, thoroughly study all instructions and illustrations before you begin to install or operate the lift. Pay particular attention to the “Important Precautions” on Page 1.
- **CAUTION:** For smooth and reliable operation, the lift must be installed square and parallel in *all* dimensions. Avoid stressing or twisting the lift at any time during installation.
- Because of the size and weight of the lift, Chief Manufacturing recommends that at least two people be available when installing the lift.
- If you have any questions concerning this installation, contact Chief Manufacturing at 1-800-582-6480.



IMPORTANT WARNINGS AND CAUTIONS!

- **WARNING:** This is an electrical device. All electrical installation procedures should be performed by a qualified electrician.
- **WARNING:** Improper installation can result in serious personal injury! Make sure that the ceiling structural members can support a redundant weight factor five times the total weight of the equipment. If the ceiling can not support this weight, reinforce the ceiling before installing the lift.
- **WARNING:** Be aware during the installation that this is a motorized device, and there are pinch points for people and for electrical wiring.
- **WARNING:** Be aware of the potential for personal injury or damage to the lift if it is not adequately mounted. The lift (without a projector) weighs approximately 85 lbs (38.5 kg).
- **WARNING:** Plenum rating requires the unit to be hard wired through the provided strain relief, use of Class II control wiring, and all open holes in housing (except joist tabs) must be sealed using foil tape.
- **WARNING:** Electrical outlets must be installed by a qualified electrician. Follow all electrical codes.
- **CAUTION:** Test the lift for shipping damage. See “PRETEST THE LIFT BEFORE INSTALLING” on page 6.
- **CAUTION:** For smooth and reliable operation, the lift must be installed square and parallel in *all* dimensions. Avoid stressing or twisting the lift at any time during installation.
- **CAUTION:** Changes or modifications not approved by Chief Manufacturing could void user’s warranty.
- **CAUTION:** Improper weight distribution could lead to equipment damage. Make certain projector weight is centered on cradle when mounted.

TOOLS REQUIRED FOR INSTALLATION

- Phillips screwdrivers, No. 1 and No. 2
- Electric drill and bit set
- Pliers (heavy-duty)
- Electrical wire cutter/stripper
- If suspended from threaded rods: Socket set with extension and open wrenches

NOTE: Other tools may be required depending on the method of installing the lift in the ceiling.

CONTENTS

DIMENSIONAL DRAWING	3
SPECIFICATIONS	4
ACCESSORIES	5
PRETEST THE LIFT BEFORE INSTALLING	6
PREPARE THE CEILING OPENING AND INSTALL THE LIFT	7
General Guidelines	7
Installation in a Suspended Ceiling (using threaded rods)	8
Installation in a Wood Framework (or Side-Mounted to Joists)	9
CONNECT POWER TO THE LIFT	10
Non Plenum Rated Installation	10
Plenum Rated Installation	10
(OPTIONAL) INSTALLING WIRING COVER.....	11
INSTALL THE PROJECTOR ON THE LIFT	12
Install and Route Cables	12
ADJUSTMENTS	13
Adjust Travel	13
Adjust the Aim of the Projector	13
OUTSIDE TERMINAL WIRING EXAMPLES	14
Push Button	14
Supplied SPST Switch Using Internal 24VAC Power Supply ...	14
Supplied SPST Switch Using Internal 12VDC Power Supply ...	14
Supplied SPST Switch Using External Power Supply	14
SPDT Switch or 2 Dry Contact Closures, Momentary or Latching	15
Internal 12VDC Power Supply 2.5A Maximum	15
Internal 24VAC Power Supply, 1.2A Max	15
Internal Dry Contact Closures.....	15
Service Position	15
INSIDE TERMINAL WIRING EXAMPLES	16
Push Button	16
Supplied SPST Switch Using Internal 24VAC Power Supply ...	16
Supplied SPST Switch Using Internal 12VDC Power Supply ...	16
Supplied SPST Switch Using External Power Supply	16
SPDT Switch or 2 Dry Contact Closures, Momentary or Latching	17
Internal 12VDC Power Supply 1.2 A Maximum	17
Internal 24VAC Power Supply, 2.5 A Maximum	17
Internal Dry Contact Closures	17
Low Voltage Sensing:	17
Service position.....	17
INTERIOR TERMINAL DESIGNATIONS	18
EXTERIOR TERMINAL DESIGNATIONS	20
TROUBLESHOOTING	22

DIMENSIONAL DRAWING

SP

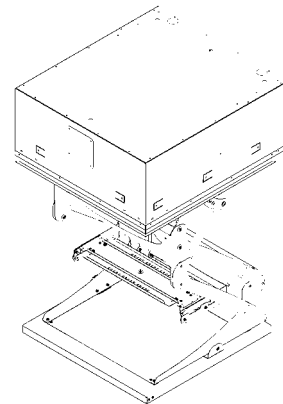
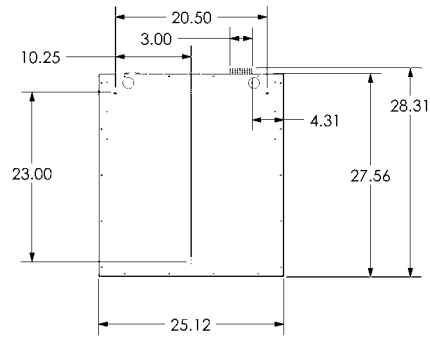

MAXIMUM AVAILABLE SPACE FOR PROJECTOR AND EQUIPMENT
HxWxD = 9.25 x 20.50 x 22.75

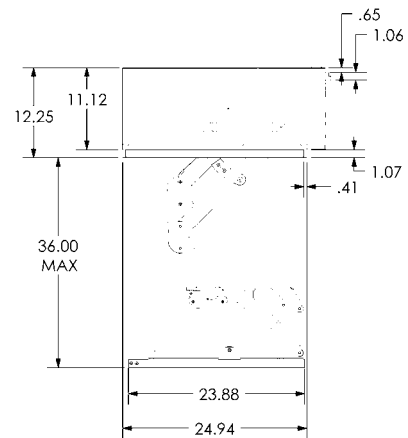
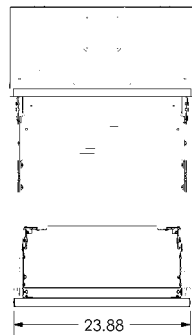

FD

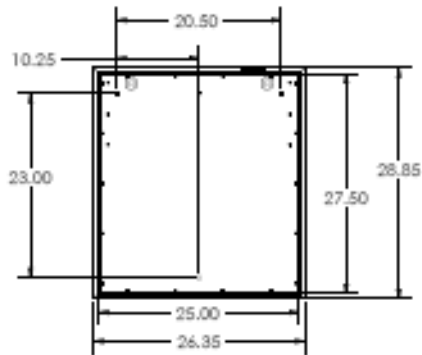

MAXIMUM AVAILABLE SPACE FOR PROJECTOR AND EQUIPMENT
HxWxD = 9.25 x 20.50 x 22.75

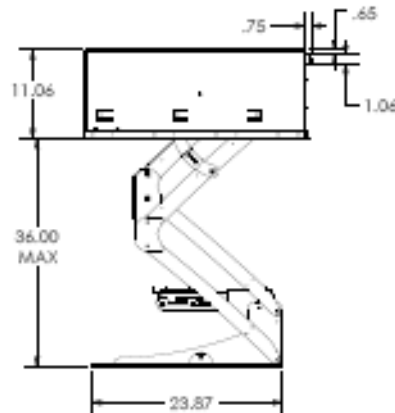

SPECIFICATIONS

OVERALL DIMENSIONS CLOSED (HxWxD):	FD: 11.06 x 26.35 x 28.85 SP: 12.25 x 25.12 x 28.31
MAXIMUM AVAILABLE SPACE FOR PROJECTOR AND EQUIPMENT (HxWxD):	9.25 x 20.50 x 22.75
CLOSURE PANEL SIZE (WxD):	23.87 x 23.87
RECOMMENDED CEILING OPENING SIZE (WxD)*:	25.50 x 28.00
AVAILABLE TRAVEL DISTANCE:	36.00"
ROLL ADJUSTMENT:	2°
PITCH ADJUSTMENT:	15°
YAW ADJUSTMENT:	10°
INTERNAL HEIGHT ADJUSTMENT:	2.00"
INTERNAL FORE/AFT ADJUSTMENT:	3.00" (1/2" INCREMENTS)
INTERNAL LEFT/RIGHT ADJUSTMENT:	2.00" (1/2" INCREMENTS)
COLOR:	WHITE
MAXIMUM WEIGHT CAPACITY:	35#
NET WEIGHT:	85#
OUTPUT RELAYS:	1.0 AMP@30VDC 0.5 AMP@125VAC 0.3 AMP@60VDC
INTERNAL POWER SUPPLY:	12VDC, 2.5A MAX 24VAC, 1.2A MAX
CURRENT DRAW:	.75A
FUSE:	4A, BUSSMAN TYPE GDB

*A NOTCH MAY BE REQUIRED TOWARD THE REAR OF THE OPENING TO CLEAR THE TERMINAL BLOCK. SEE DIMENSIONAL DRAWINGS.

ACCESSORIES

Control

ASP-401

Rocker Switch with Wall Plate



Simple lift control.

RC-10

Radio Frequency Remote Control



Multiple code settings.
Single button control of the lift.

IR-10

Infra-Red Remote Control



Discrete UP/DOWN/SERVICE commands.
Used with most universal remotes.

Installation

SMA-620

Suspended Ceiling Track Clip

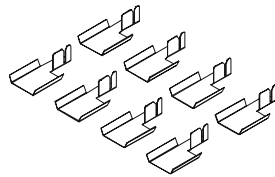

Securely attaches the suspended ceiling grid to the lift.
Includes 8 clips.

SMA-601

Single Column Mounting Plate

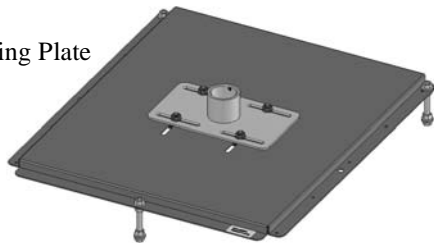

Attaches to any 1 1/2" NPT extension column.
Allows 3" fore/aft and 3" left/right adjustment.
Permits slight roll, pitch and yaw adjustment.
Allows 2" height adjustment after installation.

SMA-650

Threaded Rod Adapter



Simplifies installation using threaded rods.
Allows cable use for support/installation.

PRETEST THE LIFT BEFORE INSTALLING

IMPORTANT: Before mounting the lift in the ceiling, perform the following test to be sure that it operates properly and has not been damaged during shipping.

1. Attach supports (not supplied) to the top of the lift (see Figure 1).
2. Suspend the lift at least 3 1/2 feet high from a suitable structure [i.e. saw horses, ladders, or tables (see Figure 2)].

NOTE: The supplied momentary push button and power cord can be used to pre-test the lift (see and “OUTSIDE TERMINAL WIRING EXAMPLES” on page 13).

3. Cycle the lift through the “show” and “service” positions, making sure the unit operates smoothly.

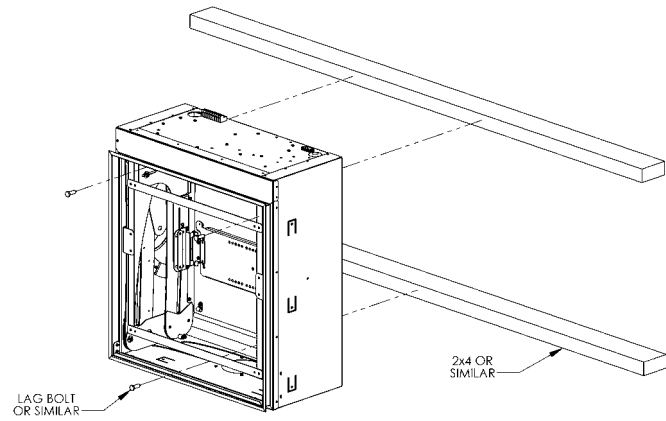

Figure 1. Support the Unit

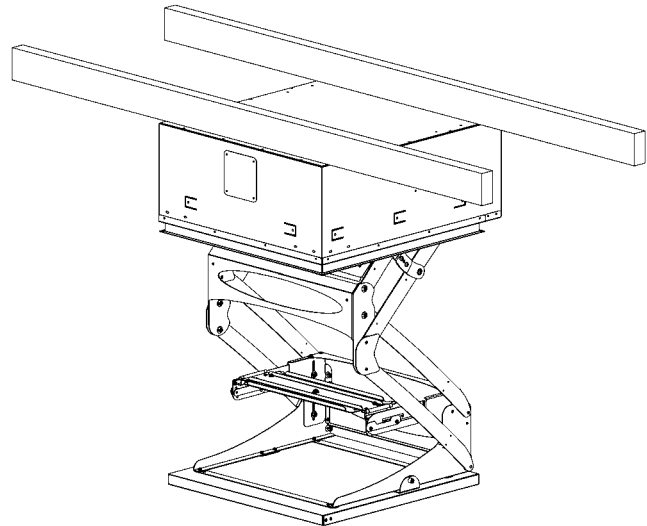

Figure 2. Suspend the Unit

PREPARE THE CEILING OPENING AND INSTALL THE LIFT

Because of the wide variety of possible mounting situations, Chief Manufacturing can only provide general guidelines for preparing the location where the Smart-Lift will be installed. Study the following information carefully, and adapt it as necessary to fit your specific installation.

WARNING: Be especially aware of the weight of the lift, and the potential for personal injury or of damage to the lift if it is not adequately mounted. The lift (without a projector) weighs approximately 85 lbs (38.5 kg).

The “General Guidelines” below, and the information on the following pages, covers the most common mounting situations:

- Suspend the lift from threaded rods that secure to the structural cross brace.
- Side-mount the lift to the ceiling joists or secure the lift to a wood framework mounting to the joists.

General Guidelines

- Carefully determine the position of the ceiling opening and its distance from, and orientation toward, the screen.
- If possible, prepare an area above the ceiling that is sufficiently larger than the lift, Leaving at least an 8” access to all sides and above the top of the lift for any future maintenance or repair.

WARNING: Improper installation can result in serious personal injury! To avoid such injury, make sure that the ceiling structural members can support a redundant weight factor *five times* the total weight of the equipment you intend to support overhead. If they cannot, the ceiling must be reinforced before you install the lift.

WARNING: Improper installation can result in serious injury! Plenum rated installations require electrically hard wiring the unit through the provided strain relief, the use of Class 2 control wiring, and all open holes in the housing (except joist tabs) must be sealed using foil tape. You must adhere to all local codes.

CAUTION: For smooth and reliable operation, the lift must be installed square and parallel in all dimensions. Avoid stressing the lift at any time during installation.

Installation in a Suspended Ceiling (using threaded rods)

You can suspend the lift housing from three 3/8-in.-dia. threaded rods (not supplied by Chief Manufacturing) First, secure the rods to a structural cross brace in the ceiling. Insert the rods through the three holes on the top side of the lift housing, or through the holes of optional brackets SMA-651, and secure them to the housing using two jam nuts (one inside, one outside). See Fig. 3.

CAUTION: For smooth and reliable operation, the lift *must* be installed square and parallel in all dimensions. Avoid stressing or twisting the lift at any time during installation.

Install the lift using threaded rods:

1. With the lift in the fully retracted position, remove the closure panel from the bottom of the lift.
2. If you are using the SMA-651, install it now.
3. Insert the 3 threaded rods through the top of the lift or SMA-651.
4. Using nuts and washers, secure the lift to the threaded rods.

Finish the suspended ceiling:

1. Cut the grid to fit the perimeter of the lift and insert it into the side channel of lift (the side channel of the lift will support the weight of the ceiling grid and tiles).
2. If using the SMA-620, see the SMA-620 instructions and install them now.
3. Cut surrounding ceiling tile to appropriate size.
4. Make sure the unit is level, square, parallel and there is no stress applied to the box (chassis).
5. Using the test push button, carefully operate the lift all the way up and down to be sure the clearances are adequate. Be prepared to stop the lift immediately if the lift begins to sound labored or one side begins to travel slower.
6. Replace surrounding ceiling tile.
7. With lift at least partway open, remove four screws securing ceiling tile retainer on bottom of tray (see Figure 4) and remove ceiling tile retainer.
8. Cut ceiling tile to fit inside ceiling tile retainer [include grid pieces if necessary (see Figure 5)] and install ceiling tile (grid) by sliding it into the open end of the ceiling tile retainer.

CAUTION: Make sure all parts assemble easily, without distorting any parts, when installing tile in the ceiling tray. Any parts protruding from the tray will cause damage when the unit closes.

9. Install ceiling tile retainer and secure using four screws.

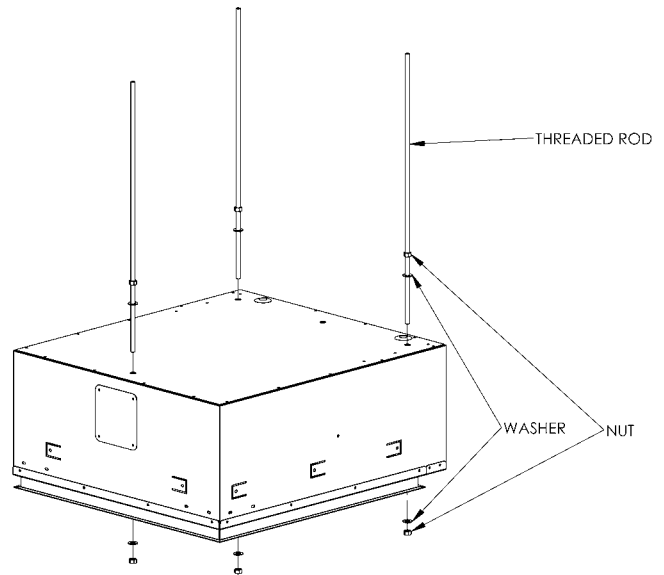

Figure 3. Threaded Rod Installation

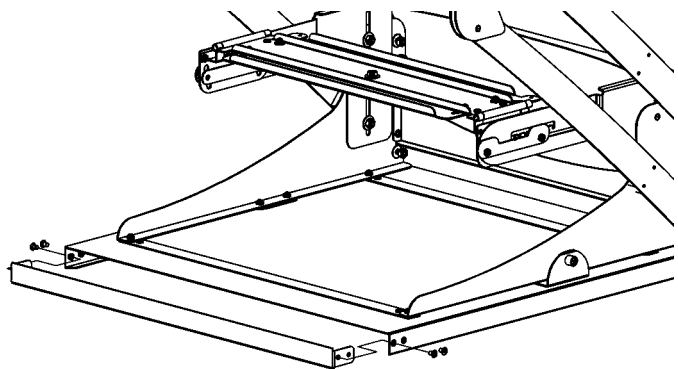

Figure 4. Remove Ceiling Retainer

SL236 shown with ceiling tile and grid installed in bottom panel



Figure 5. Grid Intersection

11. After installing the lift, use the test push button to carefully operate the lift all the way up and down to be sure the clearances are adequate. **Be prepared to stop the lift immediately** if the lift begins to sound labored or if one side or the other side begins to travel slower.
12. To maintain plenum rating, seal any openings in the lift housing (except joist tabs) using foil tape.

Installation in a Wood Framework (or Side-Mounted to Joists)

A suitable framework must be constructed to support the lift in the ceiling. Refer to for dimensions of the lift. The lift housing has mounting tabs to assist in side-mounting the lift to the ceiling joists or otherwise securing it to a wood framework.

The ideal lift installation time is after the sheetrock has been installed, but before the sheetrock has been mudded or finished.

1. Remove the closure panel from the bottom of the lift to gain access to the front and back mounting holes.

CAUTION: For smooth and reliable operation, the lift *must* be installed square and parallel in all dimensions. Avoid stressing the lift at any time during installation.

2. Position the lift in the desired location, making sure the unit is level, square, parallel and there is no stress applied to the box (chassis).
3. Secure the lift to the joists or wood framework. Drive at least six 1/4 x 1-1/4-in. lag screws through the mounting tabs around the inside of the lift housing and mounting holes across the back of the lift. There are 8 tab locations, three in each side and two in one end, and 3 mounting hole locations across the back of the lift (see Figure 6 and Figure 7). The lift requires support on two opposing sides only.
4. After installing the lift, use the test push button to carefully operate the lift all the way up and down to be sure the clearances are adequate. **Be prepared to stop the lift immediately** if the lift begins to sound labored or if one side or the other side begins to travel slower.
5. To maintain plenum rating, seal any openings in the lift housing (except joist tabs) using foil tape.

The bottom of the lift may be painted or textured as necessary to match the ceiling.

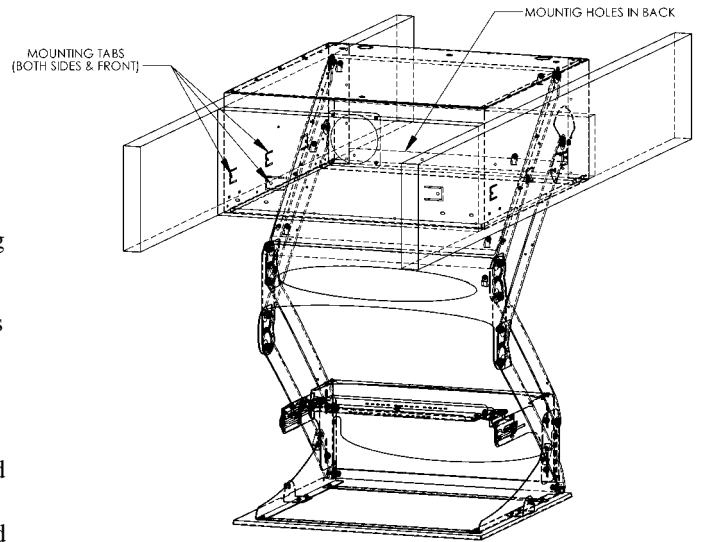

Figure 6. Mounting Locations

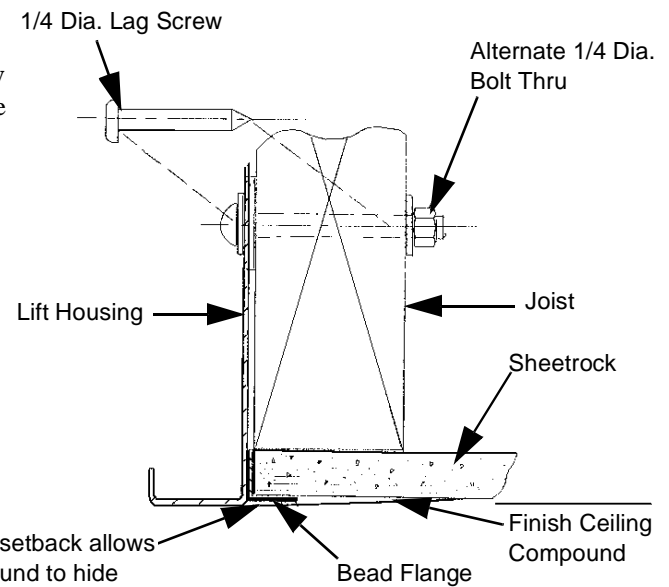

Figure 7. Mounting Method

CONNECT POWER TO THE LIFT

WARNING: Plenum rating requires hard wiring and use of Class II control wiring. Follow all local building and electrical codes.

NOTE: If the lift is cycled up and down repeatedly, the thermal overload on the motor may stop operation. Operation will resume when the thermal overload cools and resets (5 to 15 minutes).

Non Plenum Rated Installation

1. Plug the lift's power cord (supplied) into an electrical outlet.

Plenum Rated Installation



WARNING: A licensed electrician should disconnect and terminate the leads to the power cord receptacle and, using the access holes provided for a strain relief, hard wire the unit to a power source.

WARNING: Failure to disconnect and terminate power leads properly may result in equipment damage or personal injury.

1. Disconnect and terminate the electrical leads from the power cord receptacle at the interior junction box (see Figure 8).
2. Remove the electrical knockout and install the strain relief (provided).
3. Hard wire the unit to a 110V 60 Hz or 230V 50 Hz (as appropriate) 15-amp power source.
4. Replace interior outlet in a horizontal position as noted on the stickers found on the outlet cover plate.

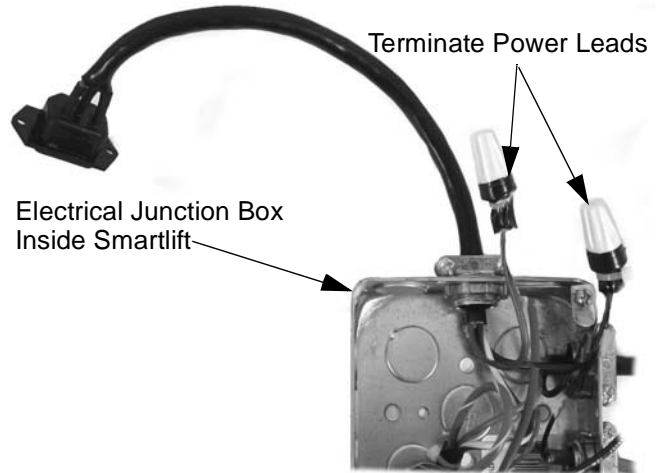

Figure 8. Disconnect and Terminate Power Cord Leads

(Optional) Installing Wiring Cover

An optional wiring cover may be installed to further protect wiring from mechanical damage.

WARNING: Make sure that power to SL-236 is OFF before proceeding!

1. Remove the control harness. (See Figure 9)
2. Using four Phillips head screws, attach cover (included in kit) over hole created in Step 1.
3. Make control connections directly to the control box. (See Inside Terminal Wiring Examples sections.)
4. Remove and save two Phillips head screws from opposite corners of cover plate, and remove cover plate from SL-236. (See Figure 9)
5. Place switch hole cover behind the cover plate and attach with two Phillips head screws from the kit.
6. Replace cover plate and attach using two Phillips head screws removed in Step 4.
7. Remove three Phillips head screws from SL-236.
8. Place motor wiring cover in place and attach with three Phillips head screws removed in Step 7.
9. Remove three Phillips head screws from SL-236.
10. Place control wiring cover in place and attach with three Phillips head screws removed in Step 9.

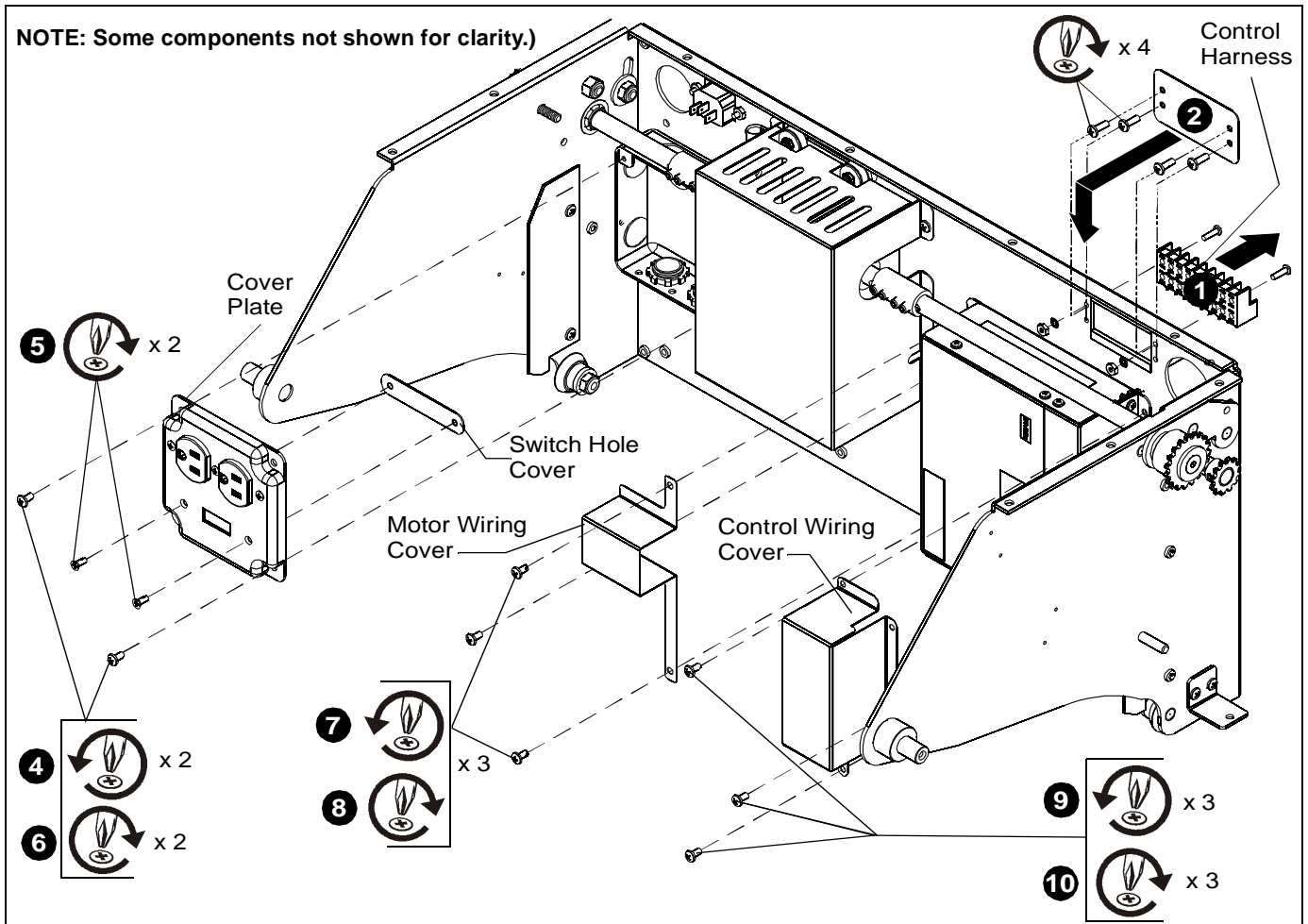

Figure 9

INSTALL THE PROJECTOR ON THE LIFT

CAUTION: Improper projector weight distribution could lead to equipment damage. Make certain projector weight is centered on cradle when mounted.

1. Install the SLB bracket on the projector (see the SLB manual for details).
2. Remove the yaw adjustment bracket from the lift (see Figure 9).
3. Place the yaw adjustment bracket over the studs on the SLB as shown, selecting the set of holes that best centers the weight of the projector.
4. Install tapered thumb nuts (minimum 3), making sure the tapered end is toward the projector.
5. Reinstall the yaw adjustment bracket with projector attached.

NOTE: If desired, the projector can be set directly on the bottom plate of the lift, not secured by the bracket. The bracket may be removed for esthetic purpose by removing four roll/height adjustment nuts (see ADJUSTMENTS).

Install and Route Cables

CAUTION: Do not attach cables to lower lifting arms or sides of cradle. This may result in damage when lift retracts.

NOTE: Two routing paths are provided, one on each side, to separate electrical and video cables.

1. Lower lift to service position.
2. Route and secure all electrical and video cables using ties and eyelets provided (see Figure 10), leaving some slack between securing points.
3. Plug the projector's power cord into one of the two outlets inside the lift. One outlet is switched and the other is continuously live. The switched outlet is marked with an "S".

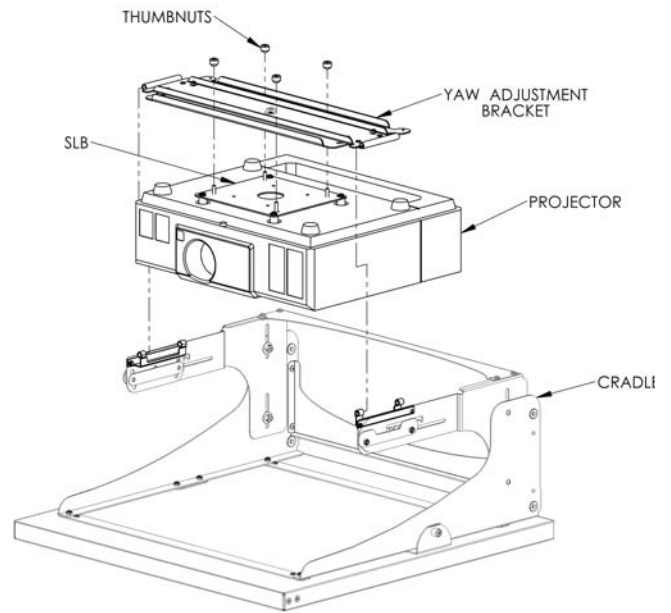

Figure 9. Install Projector

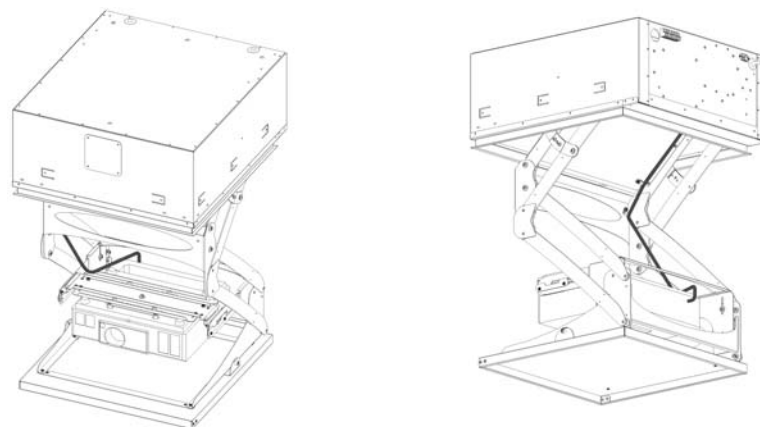

Figure 10. Cable Routing Example

ADJUSTMENTS

Adjust Travel

An access hole is located in the corner below the terminal block (see Figure 11). Using a Phillips screwdriver inserted in the access hole, adjust the stroke of the lift mechanism as follows:

CAUTION: Do not over adjust (exceed maximum travel) stroke length.

1. Shorten stroke by turning the adjustment screw clockwise one or two turns, check for the desired stroke length, and repeat as necessary.
2. Lengthen stroke by turning the adjustment screw clockwise one or two turns, check for the desired stroke length, and repeat as necessary.

Adjust the Aim of the Projector

Center the lens (see Figure 12). The aim of the projector can be adjusted in all directions, as shown:

1. Lower the lift to the 'show' position.
2. **Pitch and forward/Aft.** There are four 10-24 Nylock nuts (two on each side) on the outside of the carriage. Loosen these nuts **slightly**, tip the carriage in the slotted holes to the desired angle, and tighten the nuts. For forward and aft adjustment, loosen the four pitch adjustment nuts. Lift slightly, moving forward or aft until tray falls into desired notch and tighten the nuts.

CAUTION: Each side must be adjusted equally. Failure to adjust each side equally may result in equipment and lift damage when the lift closes.

3. **Roll/Height.** There are four 1/4-20 nuts at the rear inside corners of the cradle assembly. Slightly loosen these nuts, gently raise or lower the cradle to the desired position, and tighten the nuts.
4. **Yaw.** There are four 10-24 Nylock nuts (two on each side) on the top of the carriage. Loosen these screws **slightly**, turn the carriage in the slotted holes to the desired angle, and tighten the nuts.

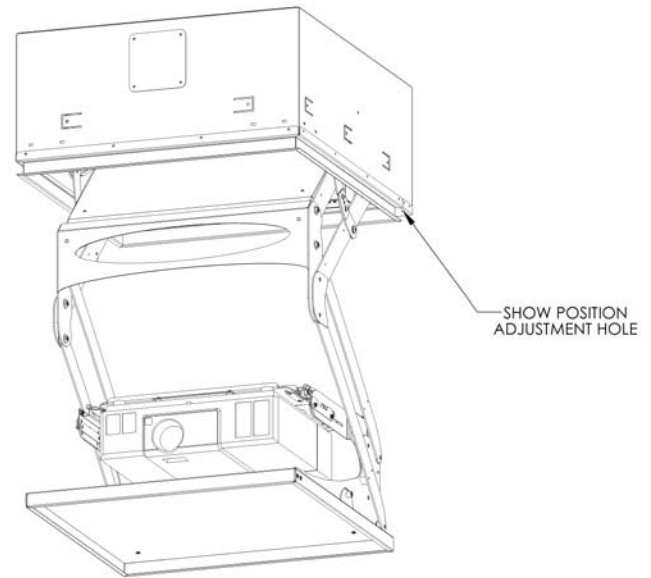

Figure 11. Travel Adjustment

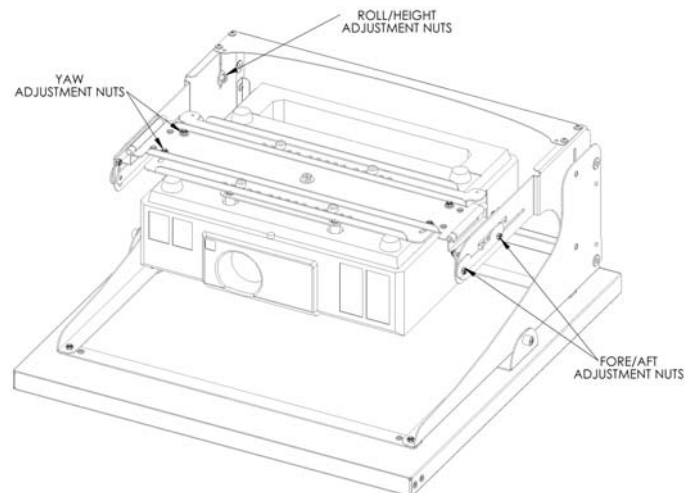

Figure 12. Projector Adjustment

OUTSIDE TERMINAL WIRING EXAMPLES

The information on the following pages cover the most common wiring options:

- Supplied Momentary Push Button
- Discrete Extend and Retract for switch or dry contacts
- 12 Volt out supply
- 24 Volt out supply
- Two dry contact closures
- Service Extend

CAUTION: Closing the unit while the projector is running may cause premature bulb failure and may damage both the lift and projector.

Push Button

Supplied Single Pole Single Throw (SPST) Switch Using Internal 24VAC Power Supply

- Connect the green jumper wire (supplied) to terminals 1 & 5 (see Figure 13).
- Connect the SPST switch (supplied) to terminals 2 & 6.

Supplied SPST Switch Using Internal 12VDC Power Supply

- Connect the green jumper wire (supplied) to terminals 5 & 9 (see Figure 14).
- Connect the SPST switch (supplied) to terminals 6 & 10.

Supplied SPST Switch Using External Power Supply

- Connect the negative of your power supply to terminal 5 (see Figure 15).
- Connect the SPST switch (supplied) to terminal 6 & the positive of your power supply.

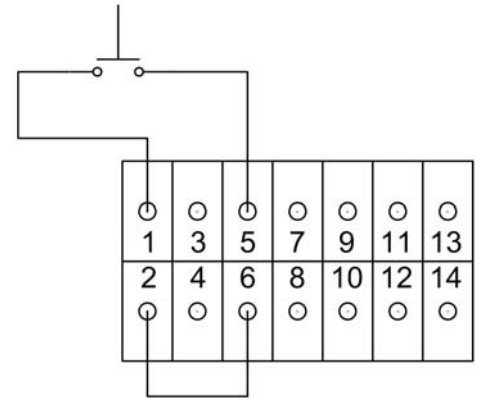

Figure 13. 24VAC Internal

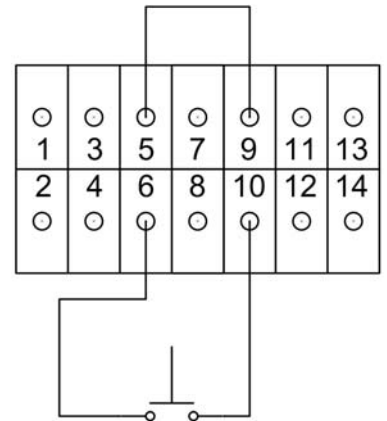

Figure 14. 12VDC Internal

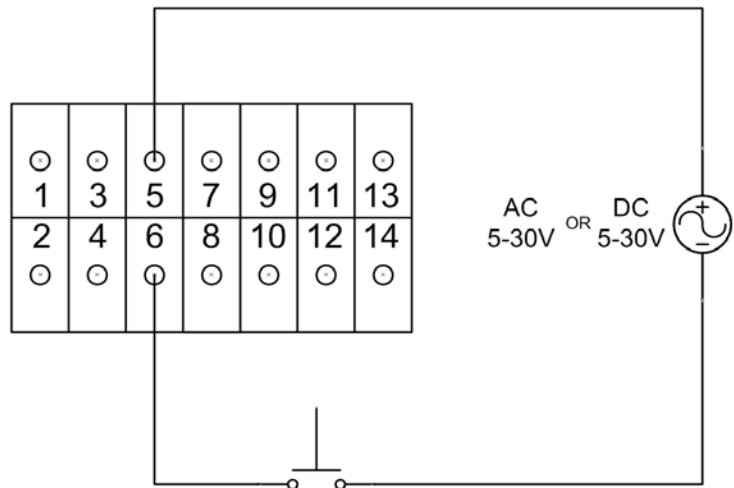

Figure 15. External Power Supply

Single Pole Double Throw (SPDT) Switch or 2 Dry Contact Closures, Momentary or Latching.

These terminals can be used with any latching contacts, momentary contacts, or a wall switch.

NOTE: The connection between the ground (#9) and any other terminal connection must be broken (open) before completing the next circuit..

- a. Connect the common wire from your switch to terminal 9 (see Figure 16).
- b. Connect the 'up' wire from your switch to terminal 3.
- c. Connect the 'down' wire from your switch to terminal 4.

Internal 12VDC Power Supply 2.5A Maximum

(+) = Terminal 10

(-) = Terminal 9

NOTE: Non regulated, open circuit voltage may exceed 18V.

Internal 24VAC power supply, 1.2 A max

(+) = Terminal 1

(-) = Terminal 2

Internal dry contact closures:

Common = Terminal 12

Closed when lift reaches show position = 14

Closed when lift is fully closed = 13

Service Position

Momentary contact between terminals 9 & 11 will lower the lift to the service position.

NOTE: To stop the lift before it reaches the service position, make a momentary contact between terminals 3 & 9.

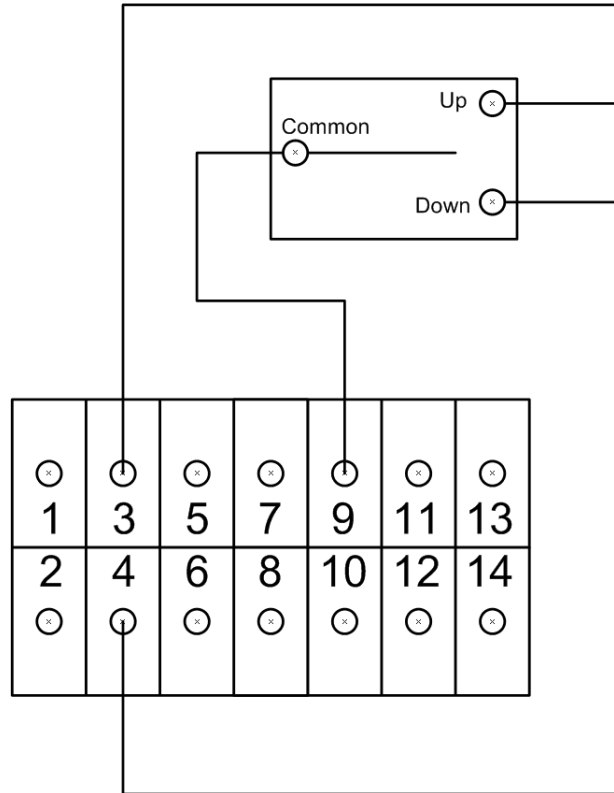

Figure 16. Dry Contacts

INSIDE TERMINAL WIRING EXAMPLES

The information on the following pages cover the most common wiring options:

- Supplied Momentary Push Button
- Discrete Extend and Retract for Switch or Dry Contacts
- 12 Volt out supply
- 24 Volt out supply
- Two dry contact closures
- Voltage Sensing
- Service Extend

CAUTION: Closing the unit while the projector is running may cause premature bulb failure and may damage both the lift and projector.

Push Button

Supplied Single Pole Single Throw (SPST) Switch Using Internal 24VAC Power Supply

- a. Connect the green jumper wire (supplied) to terminals 2 & 6 (see Figure 17).
- b. Connect the SPST switch (supplied) to terminals 1 & 5.

Supplied SPST Switch Using Internal 12VDC Power Supply

- a. Connect the green jumper wire (supplied) to terminals 6 & 10 (see Figure 18).
- b. Connect the SPST switch (supplied) to terminals 4 & 5.

Supplied SPST Switch Using External Power Supply.

- a. Connect the negative of your power supply to terminal 6 (see Figure 19).
- b. Connect the SPST switch (supplied) to terminal 5 & the positive of your power supply.

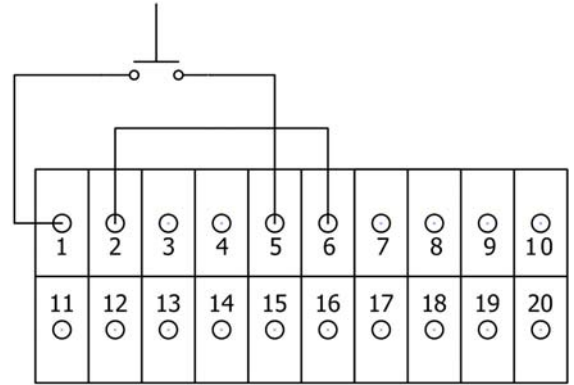

Figure 17. 24VAC Internal

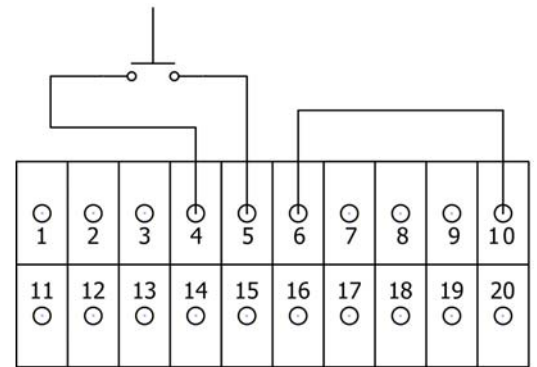

Figure 18. 12VDC Internal

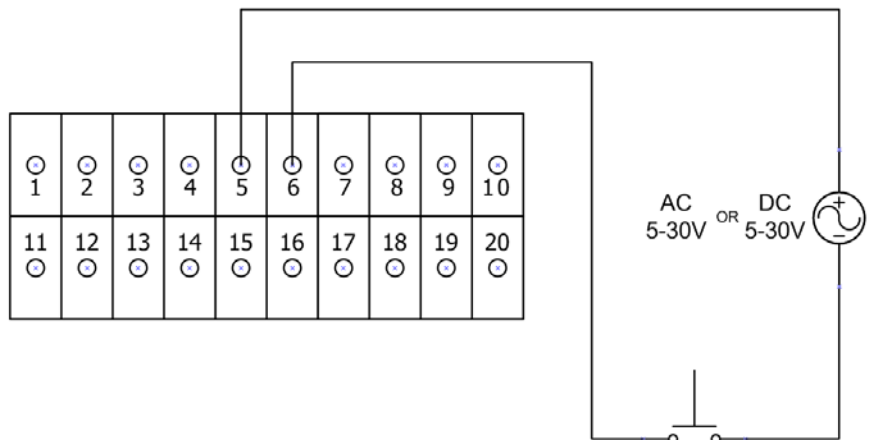

Figure 19. External Power Supply

Single Pole DOUBLE Throw (SPDT) Switch or 2 Dry Contact Closures, Momentary or Latching.

- a. Connect the common wire from your switch to terminal 13 (see Figure 20).
- b. Connect the 'up' wire from your switch to terminal 12.
- c. Connect the 'down' wire from your switch to terminal 11.

Internal 12VDC Power Supply 2.5A Maximum

(+) = Terminal 4

(-) = Terminal 3

NOTE: Non regulated, open circuit voltage may exceed 18V.

Internal 24VAC Power Supply, 1.2A Maximum

(+) = Terminal 1

(-) = Terminal 2

Internal Dry Contact Closures:

Common = Terminal 12

Closed when lift reaches show position = Terminals 16 and 17

Closed when lift is fully closed = Terminals 18 and 19

Low Voltage Sensing:

- a. Connect the positive of your power supply to terminal 7.
- b. Connect the negative of your power supply to terminal 8.

NOTE: The lift will complete a full cycle even if the supply is turned off before the lift reaches full extension.

NOTE: When the lift is in the lowered position using this option, the lift will ignore all other commands until it has completed its full cycle.

When the power supply is on, the lift will extend. When the power supply turns off, the lift will retract.

Service position:

Momentary contact between terminals 9 & 10 will lower the lift to the service position.

NOTE: To stop the lift before it reaches the service position, make a momentary contact between terminals 11 & 13.

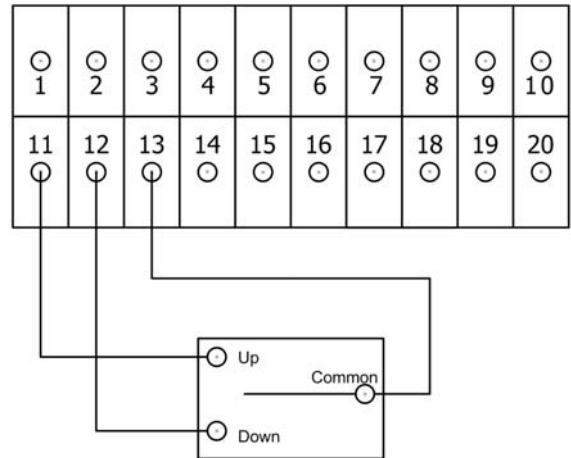

Figure 20. Dry Contacts

SMART LIFT INTERIOR BOARD BOX TERMINAL FUNCTION DEFINITIONS				
TERMINAL NUMBER	FUNCTION	DESCRIPTION	WIRING OPTIONS	NOTES
1	24 VOLT AC	24 volt AC output		This is an internal power supply for powering external devices & Remote Controllers. Chief Mfg. offers the RC-10 Radio Frequency Remote Controller which runs off of this power supply.
2	24 VOLT AC COMMON	24 volt AC common		
3	GROUND	Ground		This is an internal power supply for powering external devices &/or used for initiating specific functions (Extend/Retract 5 or Voltage Sensor 7).
4	12 VOLT DC	12 volt DC		
5	EXTEND/RETRACT	Initiates movement if lift is static, or stops movement if lift is in motion. Direction of travel will be opposite of last direction of travel.	<u>To Operate using Internal Power Source</u> Connect terminals 3 & 6 with Jumper Wire. Connect Momentary Switch to terminal 4. Connect other line of Momentary Switch to terminal 5.	Function operates on momentary switch only. Operating range is 5 – 30 Volts AC or DC.
6	EXTEND/RETRACT COMMON	Used in conjunction with Extend/Retract when using an external power source to initiate movement.	<u>To Operate using External Power Source</u> Connect External Power Supply's Common to terminal 6. Connect initiating signal to terminal 5.	
7	VOLTAGE SENSOR	When terminal senses voltage, unit will extend. When terminal senses cessation of voltage, unit will retract.	<u>Voltage Sensing</u> Connect positive lead to terminal 7. Connect Ground of switching device to terminal 8. <u>Single-Pull/Throw Latching Switch</u>	Operating range is 5 – 30 Volts AC or DC. NOT TO BE USED AS GROUND FOR FUNCTION OTHER THAN VOLTAGE SENSOR TERMINAL 7.
8	VOLTAGE SENSOR COMMON	Used in conjunction with Voltage Sensor when using an external power source to initiate movement.	Connect terminals 3 & 8 with Jumper Wire. Connect first Switch Terminal to terminal 4. Connect other Switch Terminal to terminal 7.	
9	SERVICE EXTEND	Extends unit to maximum limit, bypassing normal-use travel setting. Often used for servicing projectors in ceiling lifts.	Momentary or Latching contact to Ground terminals 3, 10, 13, or 20.	Feature not available on all models. If using Latching Switch, be sure to disengage Switch prior to initiating any other function.
10	GROUND	Ground		

11	EXTEND	Extends unit to preset travel limit. Customer within a preset maximum range may adjust travel limits.	Momentary or Latching contact to Ground terminals 3, 10, 13, or 20.	If using Latching Switch, be sure to disengage Switch prior to initiating any other function.
12	RETRACT	Retracts unit to preset travel limit. Travel limits may be adjusted by customer within a preset maximum range.		If using Latching Switch, be sure to disengage Switch prior to initiating any other function.
13	GROUND	Ground		
14	EXTEND ERROR	Immediately reverses direction of travel when triggered while unit is extending.	Momentary contact to Ground terminals 3, 10, 13, or 20.	Chief Mfg. offers the SS-10 Pressure Sensitive Safety Strip to provide this function. Please specify how many inches required spanning entire pinch zone. The SS-10 must be ordered with the ST-15 Terminals.
15	RETRACT ERROR	Immediately reverses direction of travel when triggered while unit is retracting.		
16	EXTEND LIMIT RELAY	Closes set of internal dry contacts when unit reaches full extension.		RATED FOR 1.0 AMP@30VDC 0.5 AMP@125VAC 0.3 AMP@60VDC
17	EXTEND LIMIT RELAY COMMON			
18	RETRACT LIMIT RELAY	Closes set of internal dry contacts when unit reaches full retraction.		RATED FOR 1.0 AMP@30VDC 0.5 AMP@125VAC 0.3 AMP@60VDC
19	RETRACT LIMIT RELAY COMMON			
20	GROUND	Ground		

SMART LIFT EXTERIOR 14 PIN

TERMINAL FUNCTION DEFINITION

TERMINAL NUMBER	FUNCTION	DESCRIPTION	WIRING OPTIONS	NOTES
1	24 VOLT AC	24 volt AC output		This is an internal power supply for powering external devices & Remote Controllers.
2	24 VOLT AC COMMON	24 volt AC common		Chief Mfg. offers the RC-10 Radio Frequency Remote Controller which runs off of this power supply.
3	RETRACT	Retracts unit to preset travel limit. Travel limits may be adjusted by customer within a preset maximum range.	Momentary or Latching contact to Ground terminals 9, or 11.	If using Latching Switch, be sure to disengage Switch prior to initiating any other function.
4	EXTEND	Extends unit to preset travel limit. Customer within a preset maximum range may adjust travel limits.		If using Latching Switch, be sure to disengage Switch prior to initiating any other function.
5	EXTEND/ RETRACT COMMON	Used in conjunction with Extend/Retract when using an external power source to initiate movement.	<u>To Operate using Internal Power Source</u> Connect terminals 9 & 5 with Jumper Wire. Connect Momentary Switch to terminal 10. Connect other line of Momentary Switch to terminal 6.	NOT TO BE USED AS GROUND FOR FUNCTION OTHER THAN EXTEND/RETRACT TERMINAL 5.
6	EXTEND/ RETRACT	Initiates movement if lift is static, or stops movement if lift is in motion. Direction of travel will be opposite of last direction of travel.	<u>To Operate using External Power Source</u> Connect External Power Supply's Common to terminal 5. Connect initiating signal to terminal 6.	Function operates on momentary switch only. Operating range is 5 – 30 Volts AC or DC.
7	RETRACT ERROR	Immediately reverses direction of travel when triggered while unit is retracting.	Momentary contact to Ground terminals 9, or 11.	Chief Mfg. offers the SS-10 Pressure Sensitive Safety Strip to provide this function. Please specify how many inches required to span entire pinch zone. The SS-10 must be ordered with the ST-15 Terminals.
8	EXTEND ERROR	Immediately reverses direction of travel when triggered while unit is extending.		
9	GROUND	Ground		This is an internal power supply for powering external devices &/or used for initiating specific functions (Extend/Retract 6).
10	12 VOLT DC	12 volt DC		
11	Service Extend	Extends unit to maximum limit, bypassing normal-use travel setting Often used for servicing projectors in ceiling lifts.	Momentary or Latching contacts to Ground terminals 3, 10, 13, or 20	Feature not available on all models. If using Latching Switch, be sure to disengage Switch prior to initiating any other function

12	LIMIT RELAY COMMON			RATED FOR 1.0 AMP@30VDC 0.5 AMP@125VAC 0.3 AMP@60VDC
13	RETRACT LIMIT RELAY	Closes set of internal dry contacts when unit reaches full retraction.		
14	EXTEND LIMIT RELAY	Closes set of internal dry contacts when unit reaches full extension.		

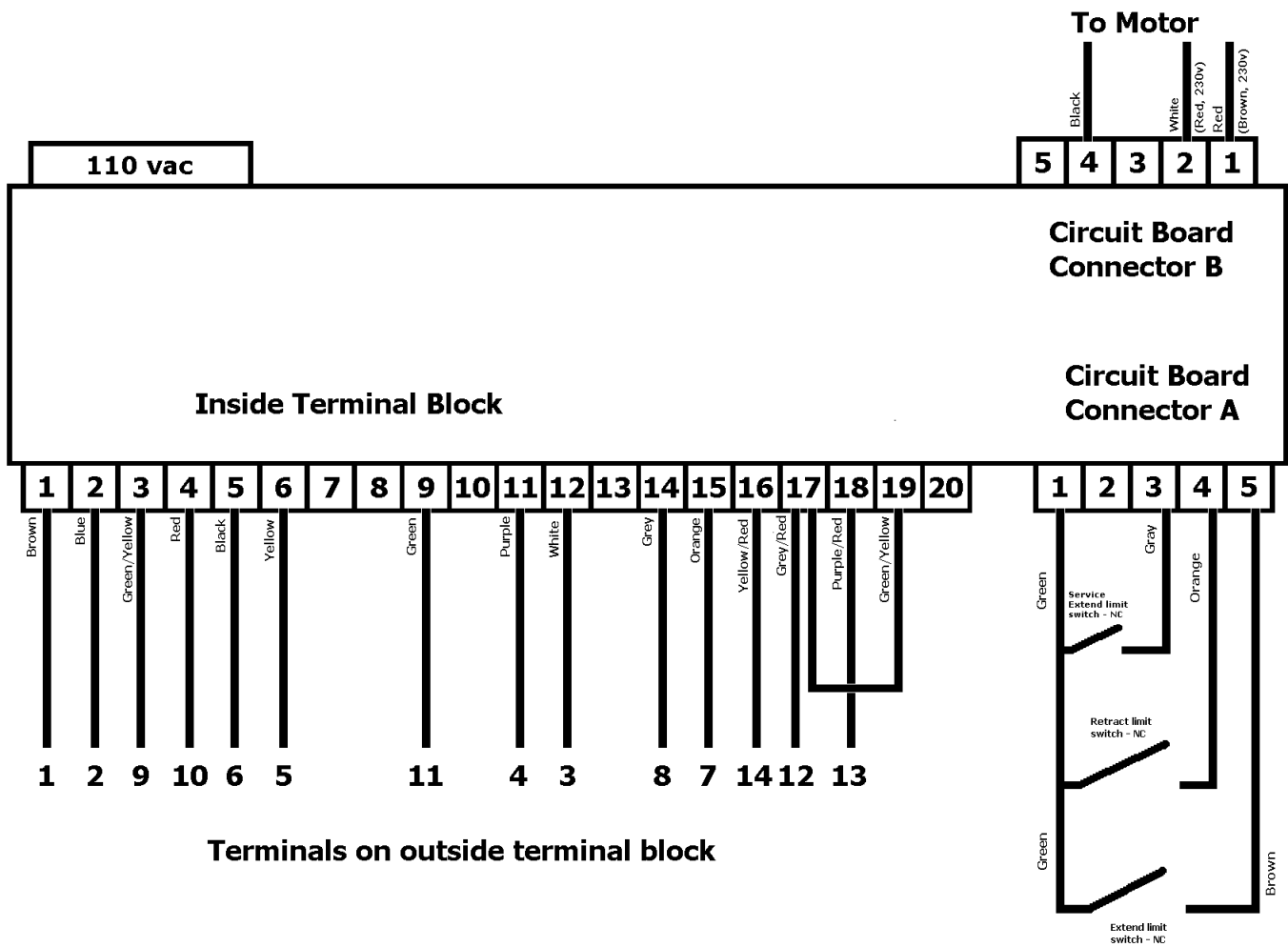

TROUBLESHOOTING

SYMPTOM	POSSIBLE CAUSE	CORRECTIVE ACTION
LIFT DOES NOT RESPOND	12V TRIGGER OPTION BEING USED	NORMAL OPERATION SEE NOTES ON 'LOW VOLTAGE SENSING' PAGE# 16
	NO POWER	VERIFY POWER TO LIFT
	FUSE BLOWN	CHECK FUSE ON CONTROL BOX
	LIMIT SWITCH	CALL CHIEF FOR VERIFICATION
	FAILED CONTROL BOX	CALL CHIEF FOR VERIFICATION
LIFT WILL NOT LOWER/RAISE CONTROL BOX CLICKS MOTOR SILENT	OVERHEATED MOTOR	LET MOTOR COOL FOR 5- 15 MINUTES.
	FAILED MOTOR	CALL CHIEF FOR VERIFICATION
LIFT WILL NOT LOWER/RAISE CONTROL BOX CLICKS MOTOR HUMS	BINDING MECHANISM	MAKE SURE CABLES ARE ROUTED PROPERLY SEE 'INSTALL AND ROUTE CABLES' PAGE# 11
	FAILED MOTOR	CALL CHIEF FOR VERIFICATION
	FAILED CONTROL BOX	CALL CHIEF FOR VERIFICATION
PROJECTOR CRADLE / BOTTOM PANEL LOWER ON ONE SIDE.	NORMAL OPERATION	A DIFFERENCE OF UP TO 3/16" WITHIN THE FINAL 4" OF TRAVEL IS NORMAL WHEN THE LIFT IS EXTENDED BEYOND 4", UP TO 3/8" DIFFERENCE IS NORMAL
	LIFTING LINKS OUT OF ADJUSTMENT	CALL CHIEF
	LIFTING BRACKET DAMAGED	CALL CHIEF
PROJECTOR CRADLE / BOTTOM PANEL SIGNIFICANTLY LOWER ON ONE SIDE	DAMAGED HINGE ASSEMBLY	CALL CHIEF
	LIFTING BRACKET DAMAGED	CALL CHIEF
HOOKS ON LIFTING BRACKET DO NOT CATCH THE ROLLERS ON THE PROJECTOR CRADLE.	BINDING MECHANISM	MAKE SURE CABLES ARE ROUTED PROPERLY SEE 'INSTALL AND ROUTE CABLES' PAGE# 11
	LIFTING LINKS OUT OF ADJUSTMENT	CALL CHIEF
	LIFTING BRACKET DAMAGED	CALL CHIEF
	DAMAGED HINGE ASSEMBLY	CALL CHIEF

PAGE LEFT BLANK INTENTIONALLY