



QuietTest Twin Blower Ventilator

(For Ceiling Use)

MODEL: QT130

DESCRIPTION

- For bathrooms up to 110 sq. ft. (10.2M²), other rooms up to 150 sq. ft. (13.9M²).
- Sturdy brown-enamel steel housing is lined with sound-deadening foam for quiet operation.
- Low RPM motor plugs into prewired junction box.
- Motor and twin blowers dynamically balanced for smooth, quiet operation.
- Vents horizontally or vertically with 3¹/₄" x 10" duct. Duct collar with quiet backdraft damper included.
- Installs easily between 16" O.C. joists with slotted mounting brackets. Slots on the sides of the housing provide alternative mounting.
- Wiring knockouts located on the top and back of the housing.
- Refer to NuTone's catalog for a complete line of accessories to effectively adapt this Fan to your construction requirements.
- Energy Star® Qualified.

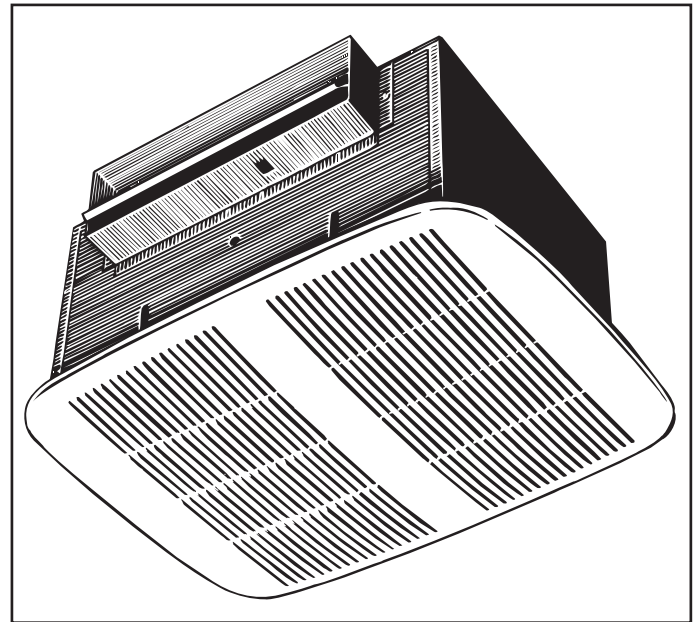

DESIGN FEATURES

- HVI Air Delivery:** **Vertically:** 120 CFM (56.6LS).
Horizontally: 130 CFM (61.3LS).
- HVI Sound Level:** .9 Sones vertically or 1.0 horizontally.
- Dimensions:** **Housing:** 14¹/₄" L x 10" W x 9" D (36.2CM x 25.4CM x 22.8CM).
Grille: 16¹/₂" L x 12³/₃₂" W x 5⁵/₈" D (41.9CM x 30.7CM x 1.6CM).
- Material & Finish:** **Housing:** Galvanized steel.
Grille: White Polymeric.
- Motor:** Thermally protected. 120 v AC, 60 Hz, .5 amps.
- Blower Wheel:** Two (2) aluminum, electronically balanced.
- Duct Size:** 3¹/₄" x 10".
- Electrical Rating:** 120v, 60Hz, 0.6Amp

INSTALLATION

- Not for use in kitchens. Do not mount over range, bathtub or shower stall.
- The ventilator consists of the housing, mounting brackets, junction box, power unit/blower assembly, damper section and grille assembly.
- Suitable for use with solid-state speed control. Speed control must be purchased separately; refer to NuTone's catalog.
- Installation Instructions are provided with each unit.

ARCHITECT'S SPECIFICATIONS

Twin-Blower Ventilator shall be Model QT130 as manufactured by NuTone according to listed specifications. Unit shall ventilate 120 CFM when ducted vertically or 120 CFM when ducted horizontally at .10" S.P. at a sound level of .90 sones. Housing shall measure 14¹/₄" x 10" x 9" deep and connect to 3¹/₄" x 10" duct.



CERTIFIED TEST DATA

HVI-2100 CERTIFIED RATINGS comply with new testing technologies and procedures prescribed by the Home Ventilating Institute, for off-the-shelf products, as they are available to consumers. Product performance is rated at 0.1 in. static pressure, based on tests conducted in AMCA's state-of-the-art test laboratory. Sones are a measure of humanly-perceived loudness, based on laboratory measurements. This NuTone model is listed by Underwriters' Laboratories Inc. and Certified by the Canadian Standards Association (CSA.)

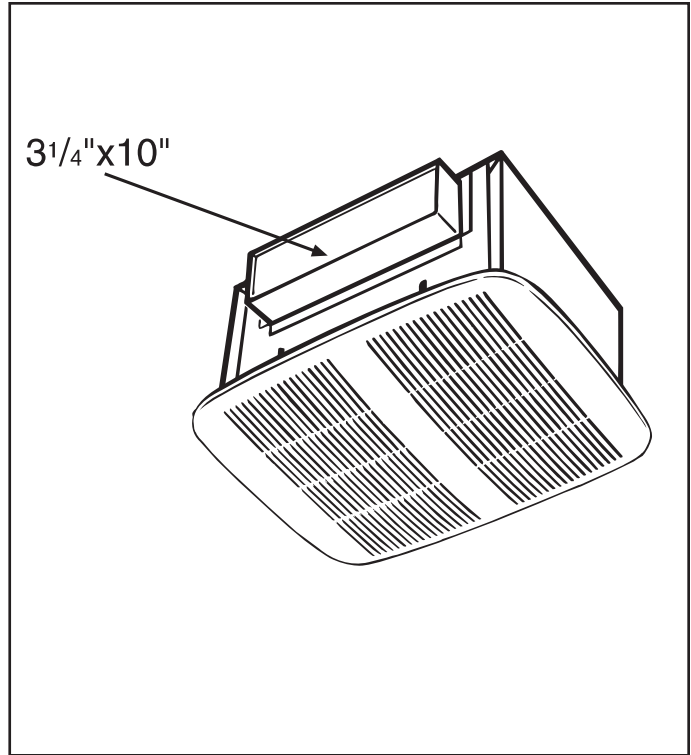

The air delivery of a ventilating system may be determined by:

1. Determine the equivalent duct length for each 90 degree elbow by adding one foot of duct length for each inch of duct diameter, i.e., a 4 inch diameter duct elbow equals 4 feet equivalent duct length and an 8 inch diameter duct elbow equals 8 feet equivalent duct length.
2. Add the total straight length of duct and the equivalent length for each elbow to obtain the total equivalent duct length.
3. Locate the intersection of the fan performance curve and the total equivalent duct length curves and draw a vertical line down to the CFM scale and read the system air performance.

(NOTE: 3 1/4" x 10" duct equals 6 inch diameter duct.)

AIR PERFORMANCE CURVE – Vertical
(6 In. Duct to 10 Foot Lengths)

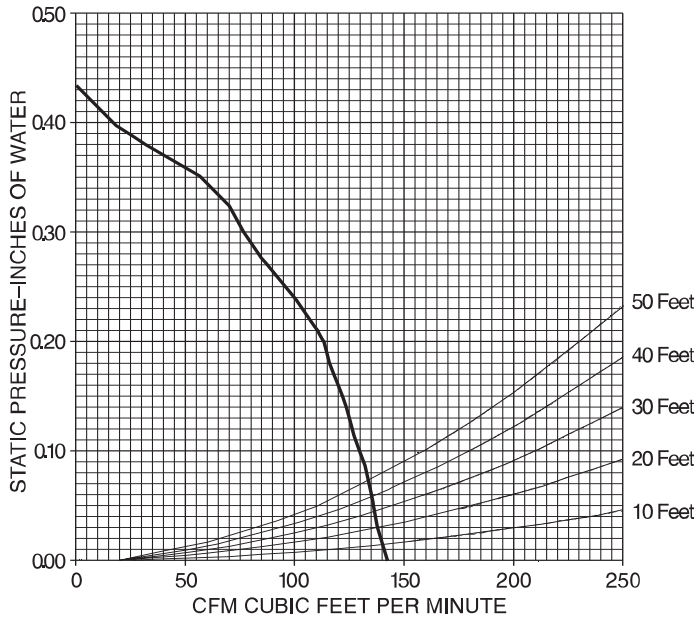

STATIC PRESSURE INCHES OF WATER	0.05	0.1	.125	0.15	0.2	0.25	0.3	0.35	0.4	0.45
CFM	135	128	126	119	105	90	73	60	–	–
LS	63.7	60.4	59.4	56.1	49.5	42.5	32.4	28.3	–	–

AIR PERFORMANCE CURVE – Horizontal
(6 In. Duct to 10 Foot Lengths)

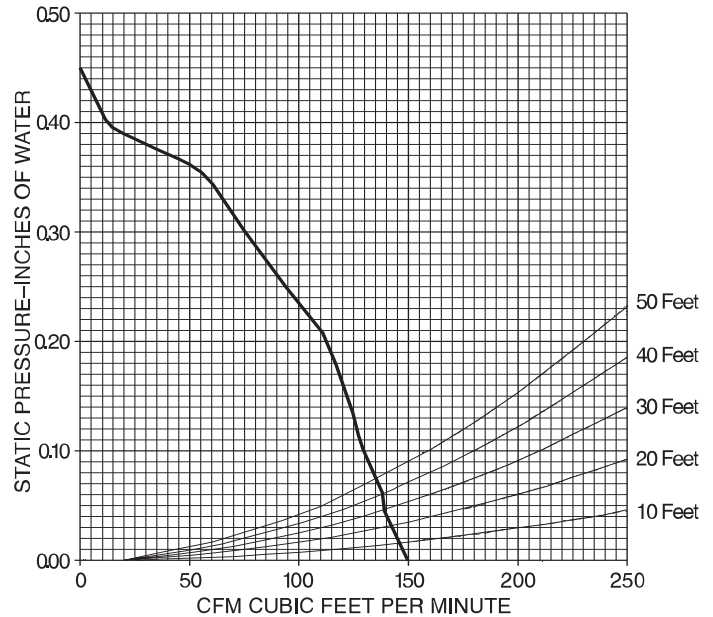

STATIC PRESSURE INCHES OF WATER	0.05	0.1	.125	0.15	0.2	0.25	0.3	0.35	0.4	0.45
CFM	140	130	127	118	106	90	76	57	–	–
LS	66	61.3	59.9	55.6	50	42.5	35.8	26.9	–	–

Product specifications subject to change without notice.