



**START UP PROCEDURE**

**WATER CONNECTION**

The National Sanitation Foundation requires the following for an NSF approved water hook-up:

- A quick disconnect water connection or enough coiled tubing so that the machine can be moved for cleaning underneath.
- An approved backflow prevention device, such as a double check valve to be installed between the machine and water supply.  
A 1/4" male flare adapter is provided. Installation to a water filter system is recommended to prevent lime and scale build-up in the machine.
- Water pipe connections and fixtures directly connected to portable water supply shall be sized, installed and maintained in accordance with federal, state and local codes.
- Flush the water line to purge any debris from the supply line.  
Connect a 1/4" pressurized water line to the 1/4" male connection (on rear of brewer) and turn the water supply on.
  - a) Minimum water pressure to the machine: 30 psi
  - b) Maximum water pressure to the machine: 80 psi

NOTE: Single head machines may be used without a pressurized water supply. (See Pour-Over Mode section)

**ELECTRICAL CONNECTION**

NOTE: Wiring connections should be performed by a qualified technician. (Refer to serial tag to verify model number of your machine)

- Remove front panel.
- Connect electrical service through rear of machine to terminal block (inside front panel) marked L1, N, and L2. (See Figures A and B)
- On dual volt units, flip voltage switch (inside front panel next to terminal block) to 120V for 120 Volt service or 240V for 120/208, or 120/240 Volt service. (See Figures A, B and table below)
- Re-install front panel.
- Turn on (plug-in) electrical service to brewer.
- Water tank will fill after a 7-second delay. The machine will make a hissing sound when this occurs. On single head models, allow approximately 1.5 minutes for the brewer to fill. On two head models, allow approximately five minutes for the brewer to fill.

**NOTE: If water supply is inadequate or not connected, display will read "P-O" after 4 minutes of fill time (Refer to Pour-Over Mode section). If Fill Cycle times out and display reads "P-O" before tank is full, turn unit OFF then ON again to reset and continue filling.**

- The tank will begin heating slightly before machine fills.
- Turn brewer on by pressing ON/OFF switch in front of machine. (Light will illuminate)
- The brewer settings can be adjusted through the front touch pad. (Refer to Adjustments section)
- The water will be hot and the brewer will be ready to brew when "READY" light illuminates.
- Set Brew volume. (Refer to Setting Brew Volume section)

**POWER REQUIREMENTS: (Refer to serial tag for voltage to be supplied.)**

Applied Volts	Models	Watts	Amps	NEMA Plug	Cord AWG	Connections
120	B-3, B-3WL, B-3WR	1800	15	5-15P, 5-20P for CUL	3X14	Hot to L1
	B-SAP, B-ID	1780	14.9			Neutral to N
120/208	B-3, B-3WL, B-3WR	2920	14.1	L14-20P	4X12	Hot to L1
	B-SAP, B-ID, B-DAP, B-DGP	2620	12.6			Neutral to N
	B-6	5110	24.6	L14-30P	4X10	Hot to L2
	B-DAP, B-DGP (30A)	4510	21.7			Ground to ground screw
120/240	B-3, B-3WL, B-3WR	3800	15.9	L14-20P	4X12	Hot to L1
	B-SAP, B-ID, B-DAP, B-DGP	3500	14.6			Neutral to N
	B-6	6600	27.5	L14-30P	4X10	Hot to L2
	B-DAP, B-DGP (30A)	6000	25			Ground to ground screw

For 120V, 15A or 20A Service (2 Wire + Ground)

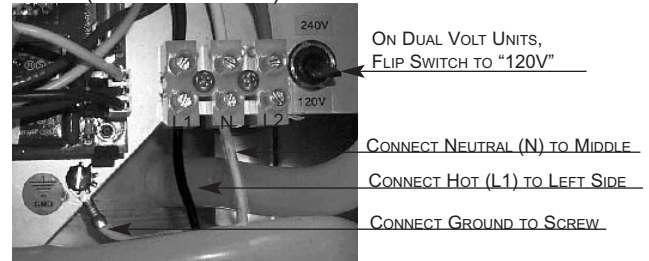

Figure A

For 120/208-240V, 20A Service (3 Wire + Ground)

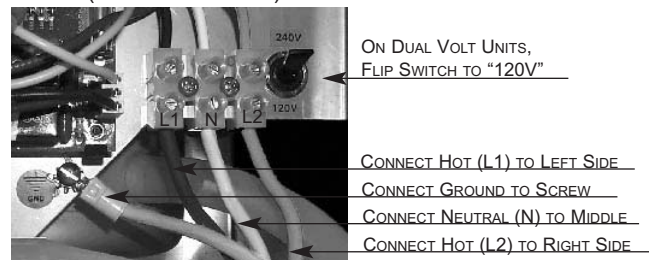

Figure B

## FACTORY SETTINGS (for each dispense head)

- Tank temperature is set at 200 degrees F.
- Brew time is pre-set at 2:20. (Volume/time to be set on-site)
- Pulse Brew is set for 1 pulse, 20 sec on, 20 sec off.
- Warmer Energy Savings mode is set for 60-minutes. ("OFF" for models without warmers)
- Low Temp / No Brew option is set to "OFF" or disabled.
- Pour over setting override is set to "no" or plumb in.
- Settings lock-out jumper on controller is set in "unlock" position.

## ADJUSTMENTS:

Refer to B-Series Programming Chart on page 5.

**NOTE: Set each dispense head individually on two head models with two controllers and serial numbers A166225 and lower (without a -P suffix). Tank temperature must be set to the same setting on both heads in order for the unit to operate properly.**

### Tank Temperature:

Left display controls this.

- Press-and-hold both "up" and "down" arrows for 5 seconds.
- The display will indicate either "d F" or "d C". (Fahrenheit or Celsius)
- Press up or down arrow to change from one scale to the other.
- Press "BREW" button to accept and proceed to the next setting.
- The display will read temperature value in the scale previously selected.
- Press up or down arrow to change temperature value.
- Press "BREW" button to accept and proceed to the next setting.

### Brew Time:

- The display will read "br ". (brew time)
- Press "BREW" button to proceed to the next setting.
- The display will read the set brew time in minutes and seconds. (ex: 2.20)
- Press up or down arrow to change time value.
- Press "BREW" button to accept and proceed to the next setting.

### Pulse Brewing Mode:

- The display will read "P-b". (pulse brew)
- Press "BREW" button to proceed to the next setting.
- The display will read "OFF" - "1"- "6".
- Press up or down arrow to change number of pulses.
- Press "BREW" button to proceed to the next setting.
- The display will read "0.05" - "0.30".
- Press up or down arrow to change pulse-on time for each pulse in seconds.
- Press "BREW" button to proceed to next setting.
- The display will read "0.05" - "0.30".
- Press up or down arrow to change pulse-off time for each pulse.
- Press "BREW" button to accept and proceed to the next setting.

### Energy Savings Mode (Warmer shut-off):

- The display will read "E-S". (energy savings)
- Press "BREW" button to proceed to the next setting.
- The display will read "Off" - "10" - "240" in multiples of 10.
- Press up or down arrow to change time value in minutes. Must be "OFF" for models without warmers.
- Press "BREW" button to accept and proceed to the next setting.

### Low Temp/No Brew Mode:

- The display will read "Ltn" (Low Temp/No Brew).
- Press "BREW" button to proceed to the next setting.
- Press up or down arrow to change to "ON" or "OFF".
- Press "BREW" to accept and proceed to the next setting.

## ADJUSTMENTS (cont.):

Refer to B-Series Programming Chart on page 5.

### Pour-Over Mode

Left display controls this.

- The display will read "P-O" (pour-over).
- Press "BREW" button to proceed to the next setting.
- Press up or down arrow to change to "YES" or "NO". Plumbed-in units must be set to "NO".
- Press "BREW" button to accept and exit menu.

## SETTING BREW VOLUME:

- Remove brew basket & spray head.
- Make sure "READY" light is on.
- Place empty server under exit nozzle to capture water.
- Press "BREW" button to fill water lines.
- Press "BREW" button again after approximately 10 seconds to stop water flow.
- Empty server then place under exit nozzle.
- Press-and-hold "BREW" button for 5 seconds until display reads "Pro", then release.
- Press-and-release "BREW" button to initiate brew.
- The brew valve opens and the time begins to count up on display.
- Water will flow into decanter.
- When water level reaches desired amount, press-and-release "BREW" button again.
- Time value will flash in the display.
- Press-and-release "BREW" button within 10 seconds to set time.
- Reinstall spray head and brew basket.
- Repeat process for each brew head.

## BREWING PROCEDURE:

- Place a new paper filter in the brew basket.
- Put desired amount of ground coffee in brew basket. (3.5 oz (100 grams) maximum)
- Place decanter or airpot under brew basket.
- Be sure lower warmer is on. (if available)
- Press "BREW" button to start brewing.

The "READY" light will flash for the entire brew cycle.

Water will dispense for the set time of brew, and light will flash after water is dispensed to denote "drip time".

(ex.. Time set for 2:30, water is dispensed for 2:30, and light continues to flash for another 1:15 for total brew cycle of 3:45.)

Do not remove the brew basket while the "READY" light is blinking.

A stop function is added to the "BREW" switch. Pressing the "BREW" switch during a brew cycle will stop the brew. Coffee will need to be emptied from brew basket and brew procedure will need to be started again.

After a brew cycle, the tank must reheat and the "READY" light must be lit before starting the next cycle. Reheat (recovery) time is dependent on voltage applied and inlet water temperature.

Approximate reheat times for a 64 oz decanter are as follows:

120 Volt supply: 3-4 minutes; 120/208 Volt supply: 30-90 seconds; 120/240 Volt supply: 0 – 30 seconds

## PULSE BREWING MODE:

- When mode is "ON" (number of pulses, pulse on, and pulse off time), and a brew cycle is initiated, water is dispensed for the ON time then stops for the OFF time to define one pulse. This repeats for number of pulses programmed. After pulsing is finished, the water continues to dispense for the remaining set time. During the pulse-off time, the water infuses the coffee and the bed rises to allow for better extraction.
- When mode is "OFF" and a brew cycle is initiated, water is dispensed continually for the entire set time without any delay.

## ENERGY SAVINGS MODE (WARMER SHUT-OFF):

(ONLY FOR MODELS WITH WARMERS)

When set time has elapsed after a brew cycle, the lights above the warmer switches will flash and the warmers will automatically turn off. To stop lights from flashing, press one of the warmer switches. To turn warmers back on, press corresponding warmer switch. The timer will reset when a new brew cycle is initiated.

Refer to Adjustments section to adjust time values or simply disable mode. Time values may be adjusted from OFF to 10 minutes to 240 minutes in increments of 10 minutes.

## LOW TEMP/NO BREW MODE:

When set to "ON", a brew cycle cannot be initiated until tank is hot and "READY" light is ON.

When set to "OFF", a brew cycle may be initiated at any time.

## POUR-OVER MODE:

**Note: Not available on B-6, B-DAP, and B-DGP (twin) models.**

Brewers are capable of operating without a pressurized water source.

If there is no pressurized water source, brewer can be set-up as a pour-over.

1. If no water is in the tank to begin with, pour about three decanters of fresh water into the basin (Fig. D). A small amount of water should remain in the basin.
2. If tank already has water, pour fresh water into basin (Fig D) until a small amount is in the basin and no longer drains into the tank.
3. Place server under the EMPTY brew basket.
4. Turn power on to machine
5. Go into Settings Mode and change "P-O" to "YES".
6. Display will read "P-O". (Fig C)
7. Wait until Ready light illuminates.
8. Press-and-release Brew button to initiate a brew cycle.
9. Water should stop flowing before READY light stops flashing to create a "short pot".
10. After tank water recovers and READY light illuminates, brewer is ready to brew coffee. See Brew Procedure.



Figure C



Figure D

If brewer is in operation (connected to a pressurized water source) and water is shut off for four minutes, display will read "P-O" (Fig C) and brewer can be used as a pour-over:

1. Place server under the EMPTY brew basket.
  2. Wait until Ready light illuminates.
  3. Press-and-release Brew button to initiate a brew cycle.
  4. Water should stop flowing before READY light stops flashing to create a "short pot".
  5. After tank water recovers and READY light illuminates, brewer is ready to brew coffee. See Brew Procedure.
- If water pressure problem is resolved, simply press Off then On.

Brew Procedure while brewer is in pour over "P-O" mode:

1. Wait until tank water heats up and READY light is on.
2. Place brew basket in place with ground coffee inside filter.
3. Pour a full (64oz) maximum container of fresh water into basin at top/front of brewer. (Fig D)
4. Place container under brew basket.
5. Press-and-release "BREW" button to initiate brew cycle.

## COUNTER:

The brewer is equipped with a counter that displays the total number of brew cycles for each dispense head. After turning the brewer on, the number will scroll across the display two times and then clears.

## CLEANING CABINET

- The outside of the brewer can be cleaned with a damp cloth, a household dusting spray or a stainless steel cleaner. Do not use an abrasive such as Scotchbrite or Brillo pads. These may mar the finish.
- Wipe the underside of the cabinet hood with a clean cloth. Be especially careful when using soap or detergent around the sprayhead. Any soap left on the deflector may impart an unpleasant taste to the first brews.

## CLEANING WARMERS

The warmer plates are easy to clean and will maintain its appearance longer if cleaned regularly. Coffee stains can be wiped off with a damp cloth. Use detergent or sanitizer for heavy deposits, but refrain from using abrasives.

## CLEANING BREW BASKET, AIRPOTS AND DECANTERS

Use commercial grade urn cleaner (as directed by manufacturer) and rinse thoroughly.



Programming for B-Series

PRESS-AND-HOLD UP & DOWN ARROWS FOR 5 SECONDS.  
 DISPLAY WILL READ AS FOLLOWS:

	DISPLAY READING	ADJUST	ADVANCE
TEMP SCALE	<input type="text" value="C"/> OR <input type="text" value="F"/>	▲ ▼	
TANK TEMP (170-202F)	<input type="text" value="93"/> OR <input type="text" value="200"/>	▲ ▼	
BREW TIME	<input type="text" value="br"/>		
BREW TIME (0:01-5:00)	<input type="text" value="2:30"/>	▲ ▼	
PULSE BREW	<input type="text" value="P-b"/>		
# OF PULSES (OFF, 1 - 6)	<input type="text" value="OFF"/> TO <input type="text" value="6"/>	▲ ▼	
PULSE ON TIME (0:05-0:30)	<input type="text" value=".20"/>	▲ ▼	
PULSE OFF TIME (0:05-0:30)	<input type="text" value=".20"/>	▲ ▼	
ENERGY SAVINGS (WARMER SHUT-OFF)	<input type="text" value="E-S"/>		
SHUT-OFF TIME (OFF, 10-240 MINUTES)	<input type="text" value="OFF"/> TO <input type="text" value="240"/>	▲ ▼	
LOW-TEMP/NO-BREW	<input type="text" value="Ltn"/>		
LOW-TEMP/ NO-BREW	<input type="text" value="On"/> OR <input type="text" value="OFF"/>	▲ ▼	
POUR-OVER MODE	<input type="text" value="P-0"/>		
POUR-OVER MODE	<input type="text" value="YES"/> OR <input type="text" value="no"/>	▲ ▼	

**Models B-3, B-3WR, B-3WL, B-SAP & B-ID Parts List**  
serial numbers A166225 and lower (without a -P suffix)

*Model B-3 Dual Voltage Unit Shown*

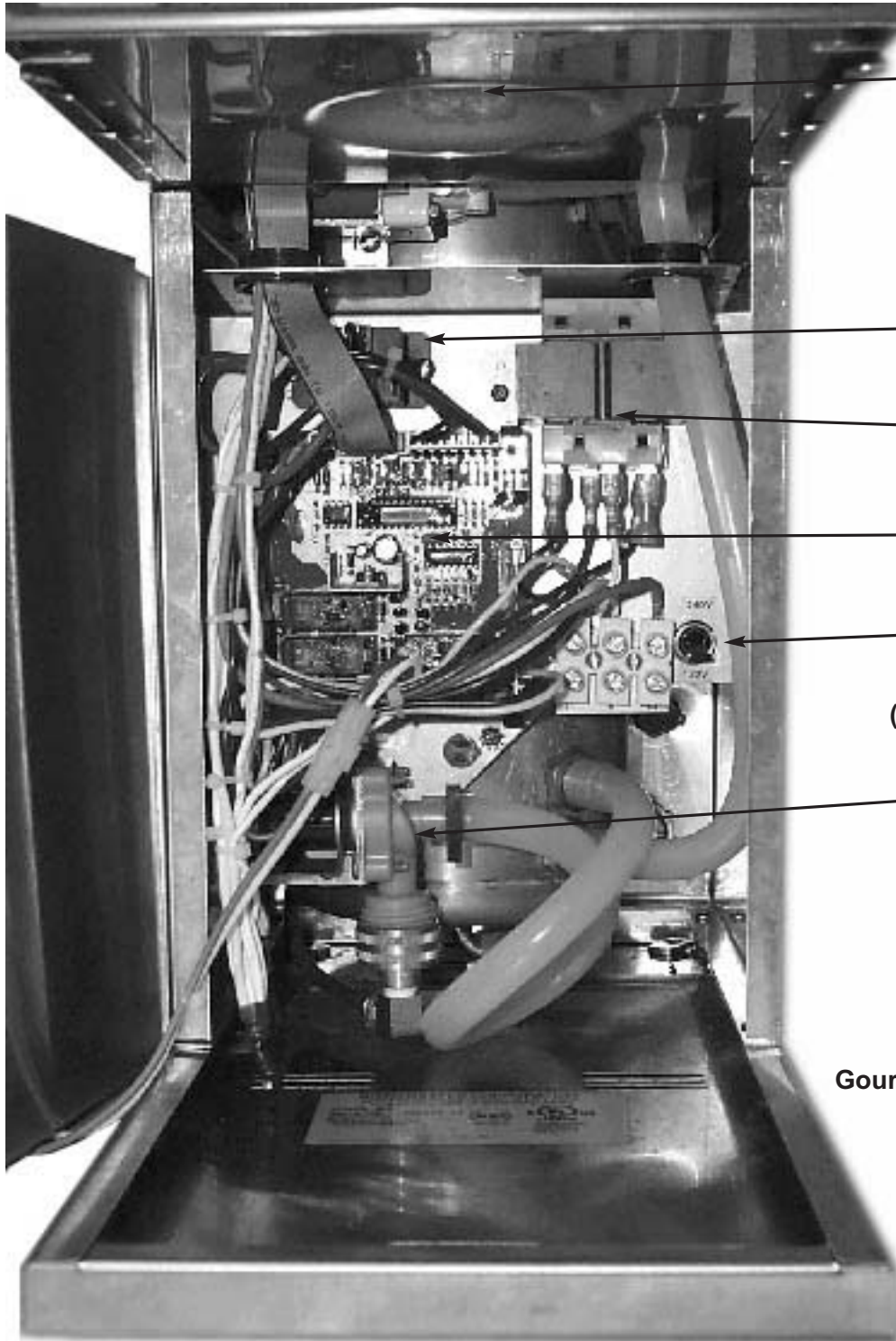

**A12124**  
Spray Head  
Deflector Kit

**A531-072**  
Heater Relay,  
12VDC coil

**A554-109**  
Transformer  
30VA, 24V ct

**A71934**  
Controller Kit

**A61467**  
Switch,  
120 or 240 Heater  
(Dual volt models only)

**A71683**  
24V Inlet Valve

**A71619**  
Brew Basket  
Assembly  
(not shown)

**A71431**  
Gourmet Brew Basket Assy  
(optional for B-SAP)  
(not shown)

**A13029**  
Warmer  
Heater  
(not shown)

**A71577**  
Warmer Plate  
(not shown)

**Models B-3, B-3WR, B-3WL, B-SAP & B-ID Parts List**  
serial numbers A166226P and higher (with a -P suffix)

*Model B-3 Dual Voltage Unit Shown*

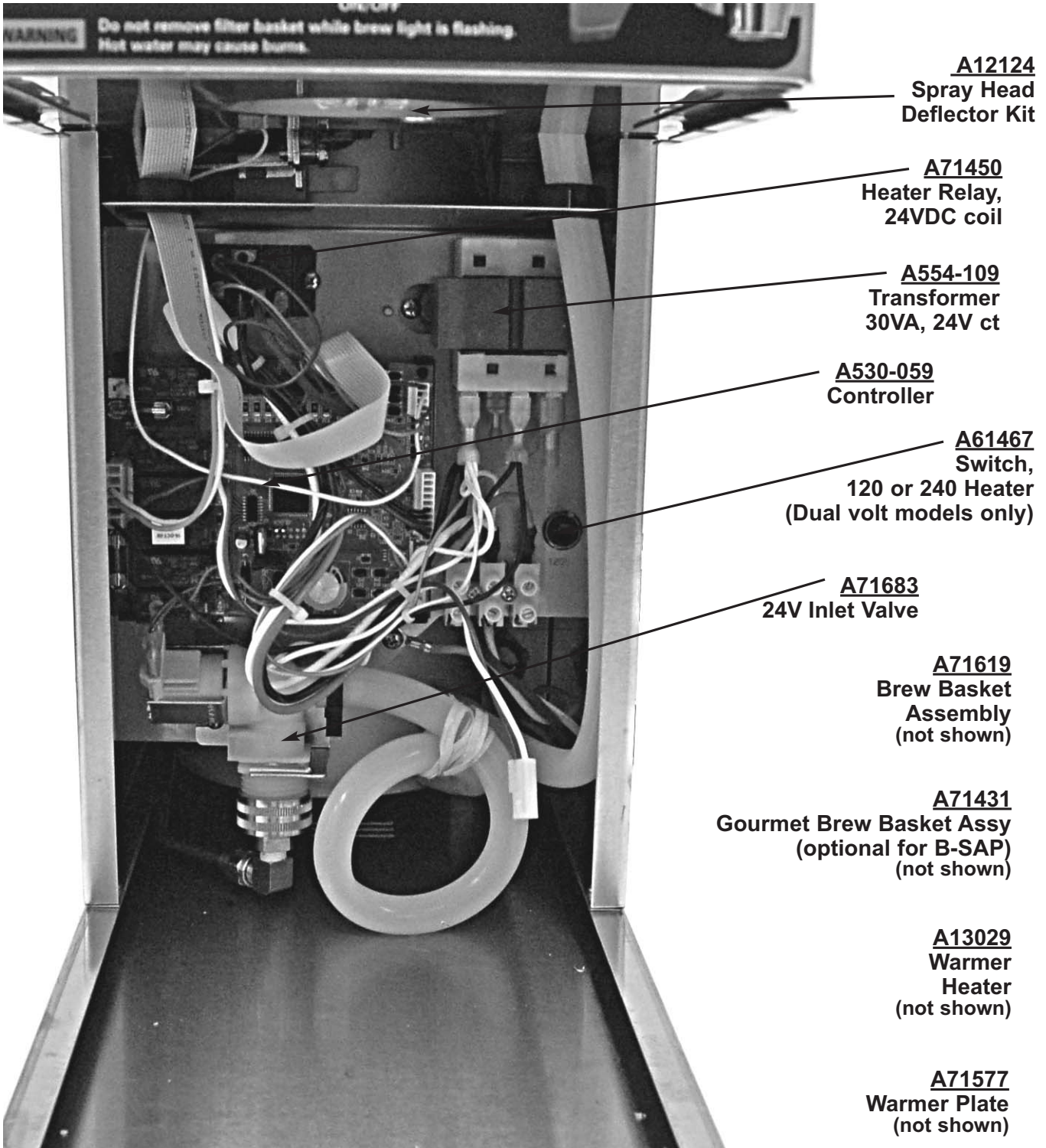

A12124  
Spray Head  
Deflector Kit

A71450  
Heater Relay,  
24VDC coil

A554-109  
Transformer  
30VA, 24V ct

A530-059  
Controller

A61467  
Switch,  
120 or 240 Heater  
(Dual volt models only)

A71683  
24V Inlet Valve

A71619  
Brew Basket  
Assembly  
(not shown)

A71431  
Gourmet Brew Basket Assy  
(optional for B-SAP)  
(not shown)

A13029  
Warmer  
Heater  
(not shown)

A71577  
Warmer Plate  
(not shown)



**Models B-3, B-3WR, B-3WL, B-SAP & B-ID Parts List**

*Dual Voltage Unit Shown*

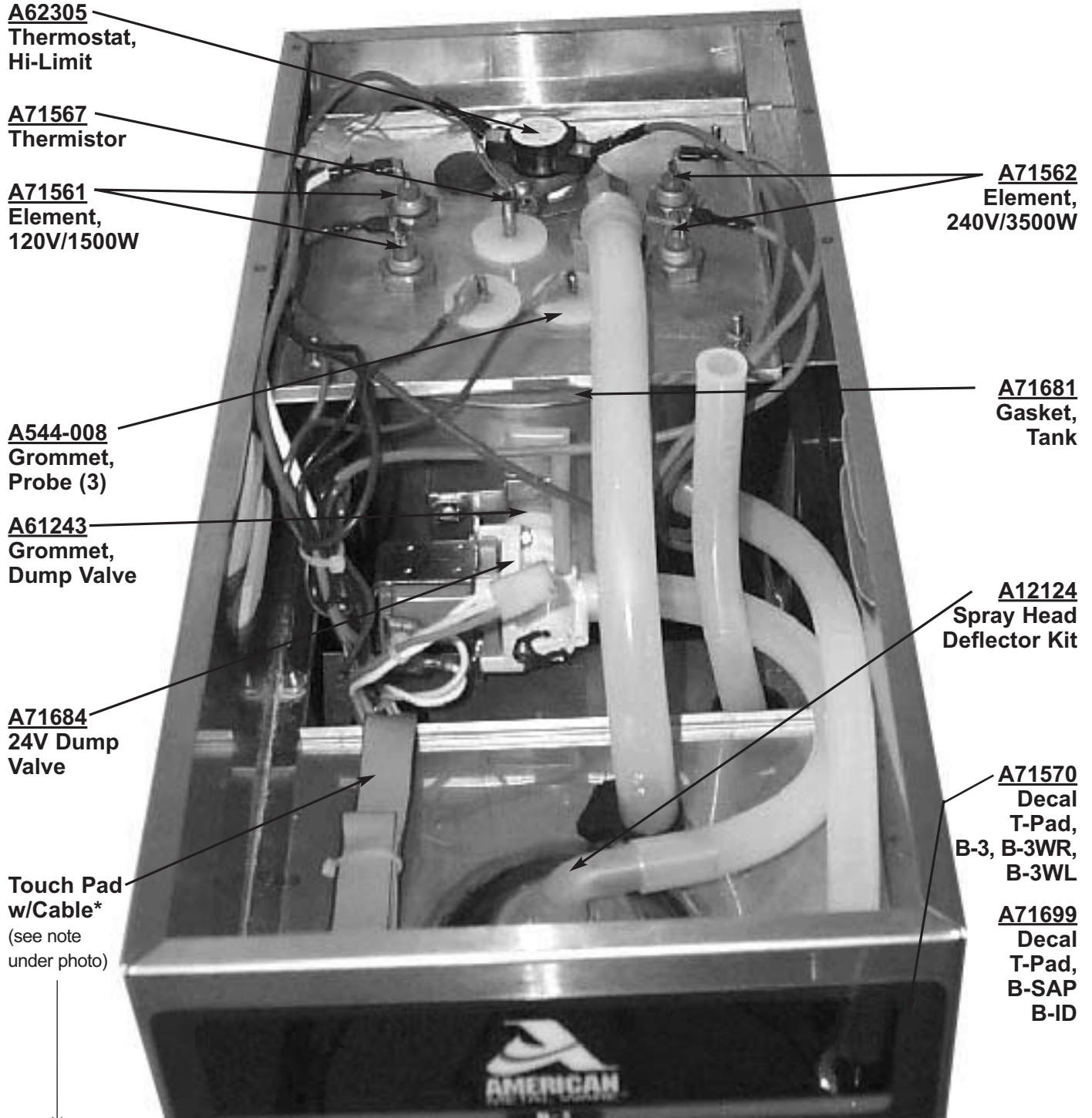

**A62305**  
Thermostat,  
Hi-Limit

**A71567**  
Thermistor

**A71561**  
Element,  
120V/1500W

**A71562**  
Element,  
240V/3500W

**A544-008**  
Grommet,  
Probe (3)

**A71681**  
Gasket,  
Tank

**A61243**  
Grommet,  
Dump Valve

**A12124**  
Spray Head  
Deflector Kit

**A71684**  
24V Dump  
Valve

**Touch Pad  
w/Cable\***  
(see note  
under photo)

**A71570**  
Decal  
T-Pad,  
B-3, B-3WR,  
B-3WL

**A71699**  
Decal  
T-Pad,  
B-SAP  
B-ID

\* A71933: used on serial number A166225 and lower (used with controller # A530-056)  
A530-061: used on serial number A166226P and higher (used with controller # A530-059)

**Models B-6, B-DGP & B-DAP Parts List**  
serial numbers A166225 and lower (without a -P suffix)

*Model B-6 Shown*

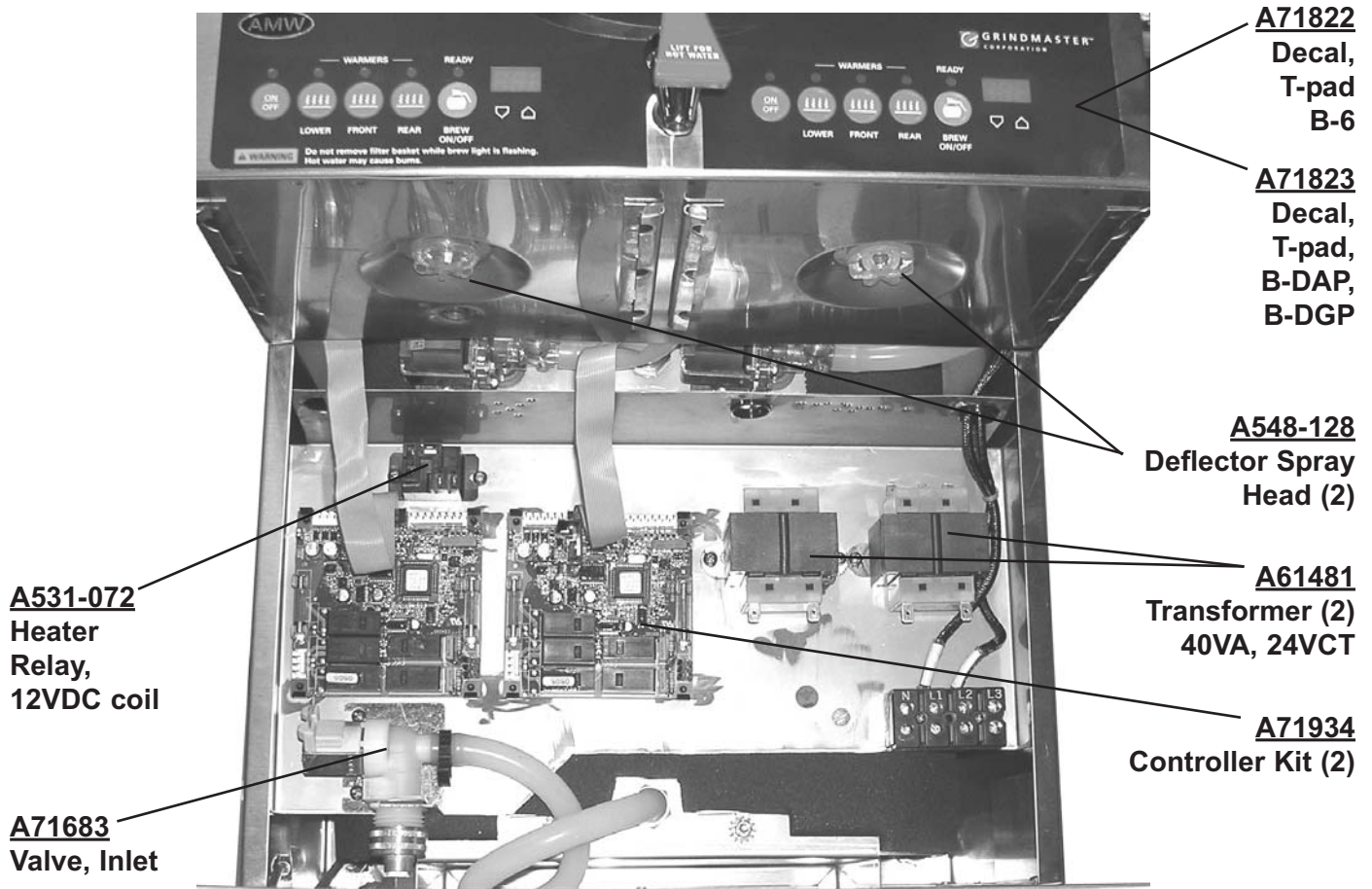

**A71619**  
Brew Basket Assy. (not shown) (2)

**A13029**  
Warmer Heater (not shown)

**A71577**  
Warmer Plate (not shown)

**A71431**  
Gourmet Brew Basket Assy (optional for B-DAP, B-DGP) (not shown)

**Models B-6, B-DGP & B-DAP Parts List**  
 serial numbers A166226P and higher (with a -P suffix)

*Model B-6 Shown*

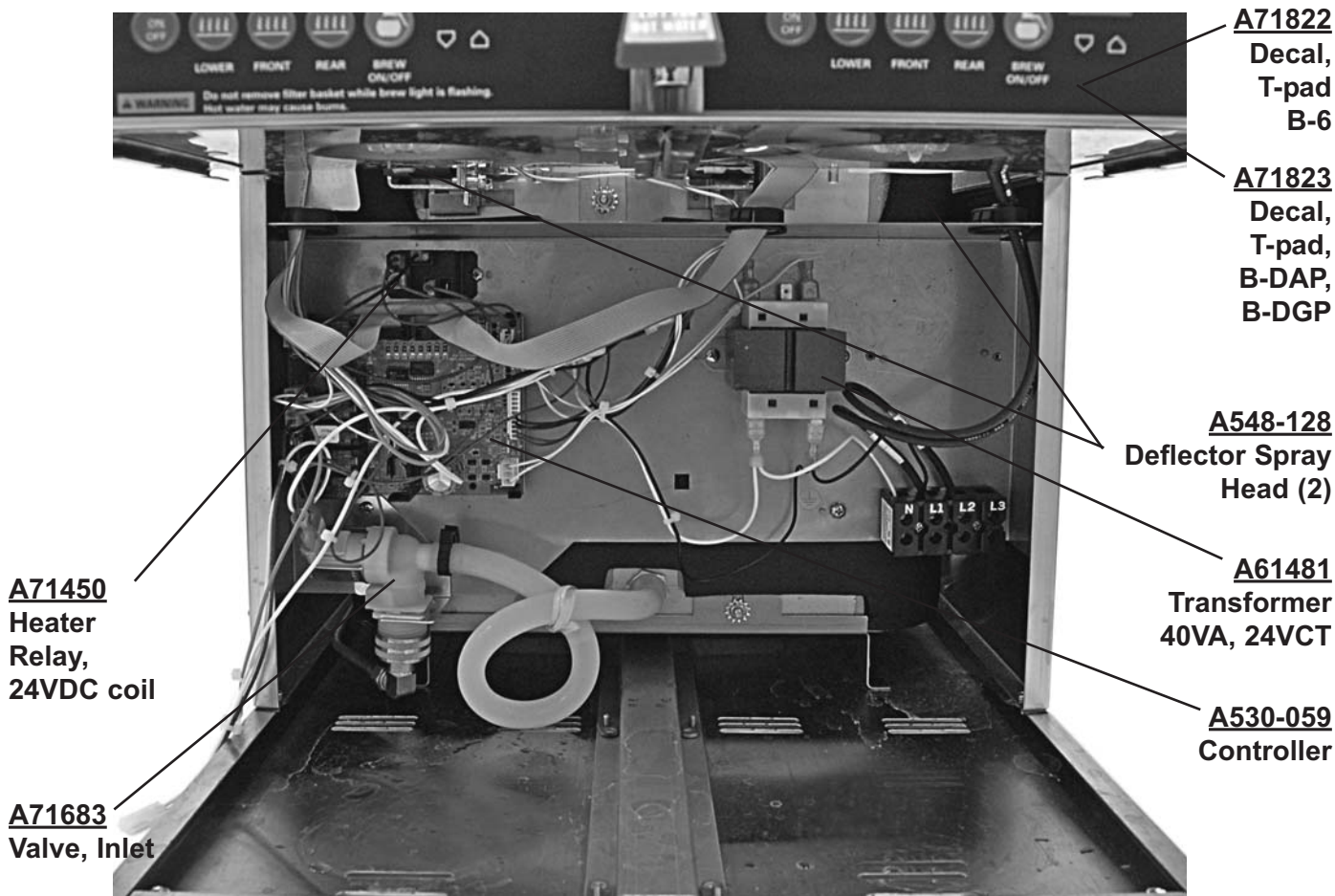

**A71619**  
 Brew Basket Assy. (not shown) (2)

**A13029**  
 Warmer Heater (not shown)

**A71577**  
 Warmer Plate (not shown)

**A71431**  
 Gourmet Brew Basket Assy (optional for B-DAP, B-DGP) (not shown)

Models B-6, B-DGP & B-DAP Parts List

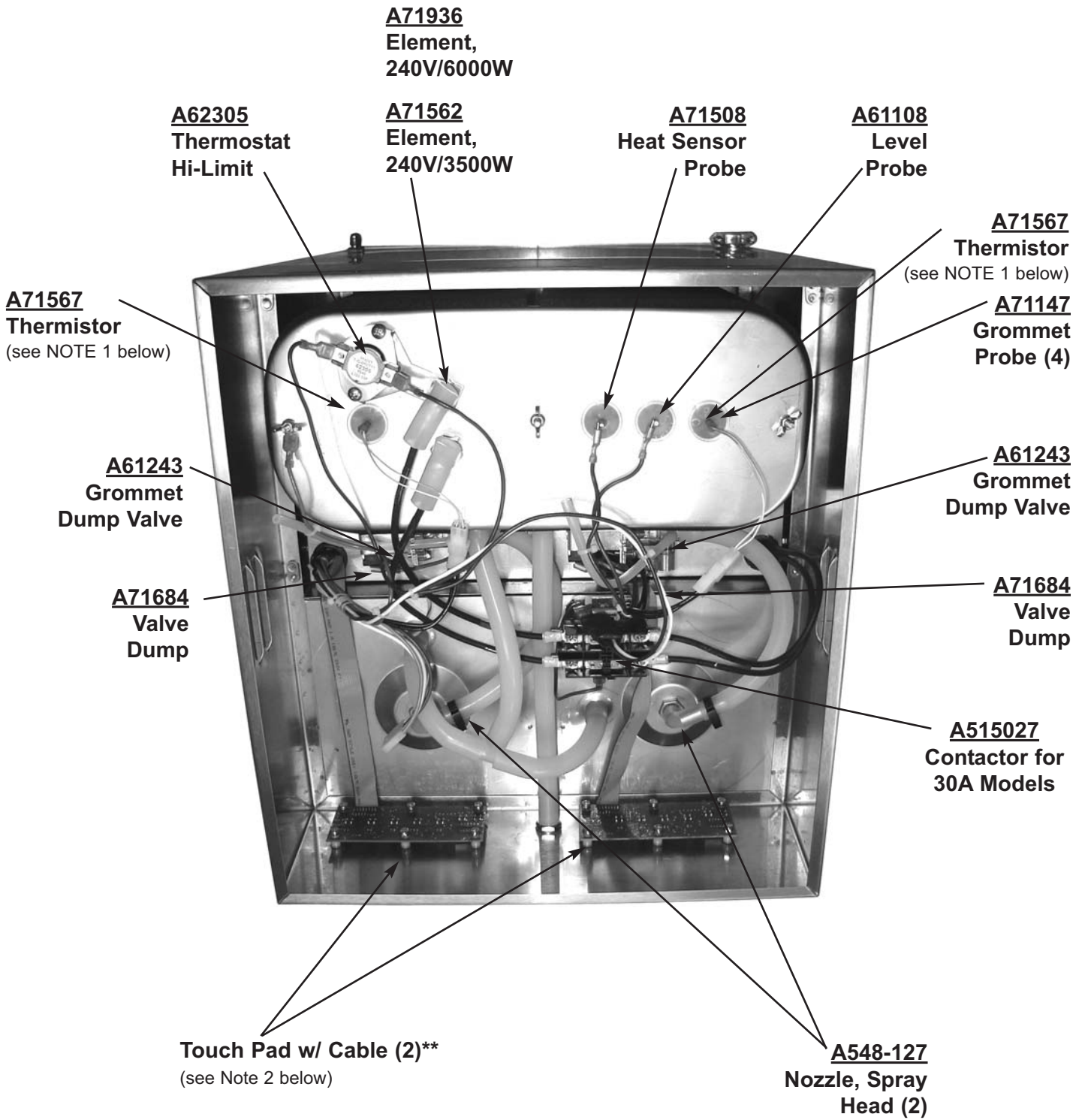

**NOTE 1:** (2) Thermistors (pn A71567) used on serial number A166225 and lower (used with controller # A530-056)  
 (1) Thermistor (pn A71567) used on serial number A166226P and higher (used with controller # A530-059)

**NOTE 2:** A71933: used on serial number A166225 and lower (used with controller # A530-056)  
 A530-061: used on serial number A166226P and higher (used with controller # A530-059)

**TROUBLESHOOTING GUIDE**

<b>Problem</b>	<b>Possible Cause</b>	<b>Solution</b>
<b>Weak coffee</b>	<ul style="list-style-type: none"> <li>• Not enough coffee used</li> <li>• Grind is too coarse</li> <li>• Water not hot enough</li> <li>• Coffee bed has dry areas</li> </ul>	<ul style="list-style-type: none"> <li>• Set to portion more coffee</li> <li>• Readjust to finer grind</li> <li>• Check spray temp; should be greater than 185°F/85°C</li> <li>• Spray deflector broken or missing. Replace</li> </ul>
<b>Strong coffee</b>	<ul style="list-style-type: none"> <li>• Too much coffee used</li> </ul>	<ul style="list-style-type: none"> <li>• Use less coffee</li> </ul>
<b>Bitter coffee</b>	<ul style="list-style-type: none"> <li>• Grind is too fine</li> </ul>	<ul style="list-style-type: none"> <li>• Use a coarser grind</li> </ul>
<b>Grounds in coffee</b>	<ul style="list-style-type: none"> <li>• Paper filter collapsed during brewing</li> </ul>	<ul style="list-style-type: none"> <li>• Use proper filter</li> <li>• Position filter carefully</li> </ul>
<b>Brew basket overflowed</b>	<ul style="list-style-type: none"> <li>• Too much coffee</li> <li>• Grind is too fine</li> <li>• Double batching</li> </ul>	<ul style="list-style-type: none"> <li>• Use no more than 3 1/2 oz. (100 grams) of coffee</li> <li>• Use a coarser grind</li> <li>• You must dump old coffee and use fresh new filter for each brew</li> </ul>
<b>Unpleasant taste</b>	<ul style="list-style-type: none"> <li>• Water tank or brew basket needs cleaning</li> </ul>	<ul style="list-style-type: none"> <li>• Clean, sanitize (delime)</li> </ul>
<b>Quantity of coffee dispensed each throw is not the same</b>	<ul style="list-style-type: none"> <li>• Lime scale build-up</li> <li>• Hose kinked</li> <li>• Dump Valve not adjusted properly</li> <li>• Defective timer</li> </ul>	<ul style="list-style-type: none"> <li>• Delime machine</li> <li>• Check hoses</li> <li>• Turn screw on Dump Valve to open fully</li> <li>• Check the length of time brewer runs with watch</li> </ul>
<b>Circuit breaker trips continuously</b>	<ul style="list-style-type: none"> <li>• Insufficient current due to use of extension cord</li> <li>• Insufficient current due to overloaded line</li> </ul>	<ul style="list-style-type: none"> <li>• Plug unit directly into outlet. Do not use extension cord</li> <li>• Designate single line for unit. Do not use multi-outlet box</li> </ul>
<b>Control board displays “P-O”</b>	<ul style="list-style-type: none"> <li>• Water supply turned off</li> <li>• Water fill valve on too long</li> </ul>	<ul style="list-style-type: none"> <li>• Turn water supply on, then reset power</li> <li>• Clean or replace water fill valve</li> </ul>
<b>Control board displays “ER2”</b>	<ul style="list-style-type: none"> <li>• Problem with thermistor</li> </ul>	<ul style="list-style-type: none"> <li>• Replace if defective</li> </ul>
<b>Water boiling (or steaming)</b>	<ul style="list-style-type: none"> <li>• Temperature set too high</li> <li>• Defective thermistor</li> </ul>	<ul style="list-style-type: none"> <li>• Check settings with actual temperature</li> </ul>
<b>No lights are on (including warmer lights)</b>	<ul style="list-style-type: none"> <li>• No power to brewer</li> <li>• Power switch turned off</li> <li>• Touch pad disconnected</li> </ul>	<ul style="list-style-type: none"> <li>• Check power at source</li> <li>• Turn switch on</li> <li>• Reconnect touchpad</li> </ul>
<b>Too much or not enough water in server</b>	<ul style="list-style-type: none"> <li>• Water volume adjustment</li> </ul>	<ul style="list-style-type: none"> <li>• Readjust</li> </ul>
<b>Spray head dripping</b>	<ul style="list-style-type: none"> <li>• Lime build up in dump valve</li> </ul>	<ul style="list-style-type: none"> <li>• Delime unit</li> </ul>
<b>Hot water spigot dripping</b>	<ul style="list-style-type: none"> <li>• Faulty seal</li> </ul>	<ul style="list-style-type: none"> <li>• Replace seal</li> </ul>
<b>Hot water spigot not dispensing</b>	<ul style="list-style-type: none"> <li>• Tube limed up</li> <li>• Defective valve seat</li> </ul>	<ul style="list-style-type: none"> <li>• Delime tank</li> <li>• Replace seat</li> </ul>
<b>Warmer failure</b>	<ul style="list-style-type: none"> <li>• Loss of power</li> <li>• Bus fuse (5 Amp) on controller board is blown</li> <li>• Defective warmer heater</li> </ul>	<ul style="list-style-type: none"> <li>• Check power source</li> <li>• Replace fuse</li> <li>• Replace defective heater</li> </ul>
<b>Water solenoids not working</b>	<ul style="list-style-type: none"> <li>• Bus fuse (1 Amp) on controller board is blown</li> </ul>	<ul style="list-style-type: none"> <li>• Replace fuse</li> </ul>
<b>One indicator light will not illuminate</b>	<ul style="list-style-type: none"> <li>• LED burned out</li> </ul>	<ul style="list-style-type: none"> <li>• Replace touchpad</li> </ul>

**Error Messages**

<b>Problem</b>	<b>Possible Causes</b>	<b>Service Check</b>	<b>Remedy</b>
<b>ER1</b>	<ul style="list-style-type: none"> <li>• Fill valve on for over 6 min. (This occurs during initial fill on some units – see <b>Initial Start-up</b>.)</li> </ul>	<ul style="list-style-type: none"> <li>• Check system for water leaks.</li> </ul>	<ul style="list-style-type: none"> <li>• Correct any leaks and reset controller.</li> </ul>
<b>ER2</b>	<ul style="list-style-type: none"> <li>• Thermistor failure or loose connections in thermistor circuit.</li> </ul>	<ul style="list-style-type: none"> <li>• Ensure that connector is securely attached to controller and that thermistor is securely connected.</li> </ul>	<ul style="list-style-type: none"> <li>• Secure connections and reset controller. If error reoccurs, replace thermistor.</li> </ul>
<b>ER3</b>	<ul style="list-style-type: none"> <li>• Thermistor is reading out of range.</li> </ul>	<ul style="list-style-type: none"> <li>• Check tank temperature.</li> </ul>	<ul style="list-style-type: none"> <li>• Replace thermistor.</li> </ul>
<b>ER4</b>	<ul style="list-style-type: none"> <li>• No heating is detected</li> </ul>	<ul style="list-style-type: none"> <li>• Verify power to heating element and high limit operation</li> </ul>	<ul style="list-style-type: none"> <li>• Repair as needed.</li> </ul>

If you still need help, call an authorized dealer in your area or our Technical Service Department. You can reach Grindmaster Corporation’s Technical Service Department at 800-695-4500 (USA & Canada only) or 502-425-4776 Monday-Friday, 8:00 AM - 6:00 PM EST. Please have the model and serial number ready so that accurate information can be given.

Prior authorization must be obtained from Grindmaster Corporation’s Technical Services Department for all warranty claims.

## Wiring Diagram

### Models B-3, B-3WR, B-3WL, B-SAP & B-ID

serial numbers A166225 and lower (without a -P suffix)

### DUAL VOLTAGE

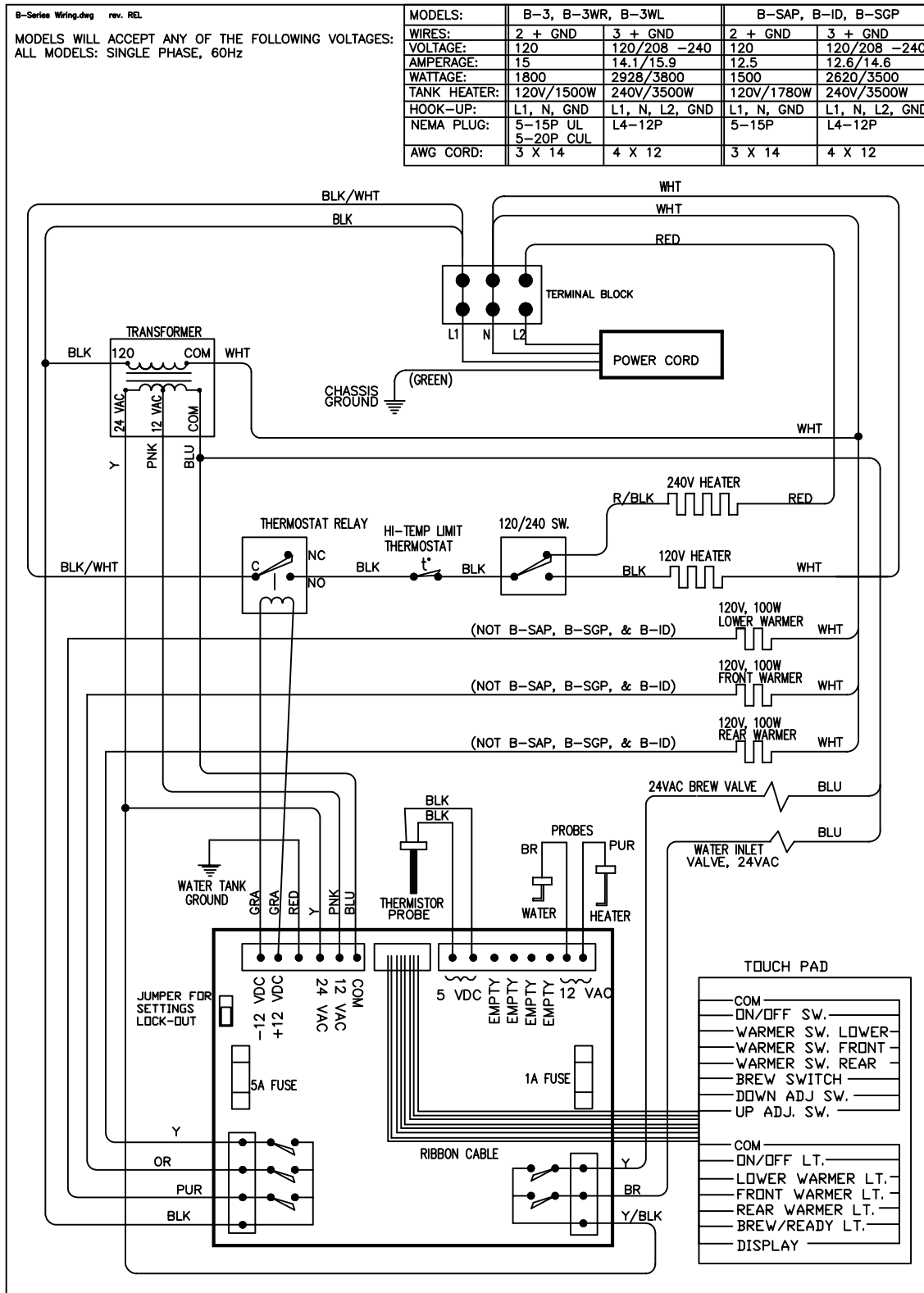



## Wiring Diagram

### Models B-6, B-DAP, B-DGP

serial numbers A166225 and lower (without a -P suffix)

TWIN HEAD B-SERIES BREWER 120/240V, 30A

MODELS:	B-6	B-DAP, B-DGP
WIRES:	3 + GND	3 + GND
VOLTAGE:	208/240	208/240
HERTZ:	60	60
AMPERAGE:	24.6/27.5	21.7/25
WARRANTY:	5110/6600	4510/6000
HOOK-UP:	L1, L2, N, GND	L1, L2, N, GND
NEMA PLUG:	L14-30P	L14-30P
AWG CORD:	4 X 10	4 X 10

B-6 30A wiring.dwg

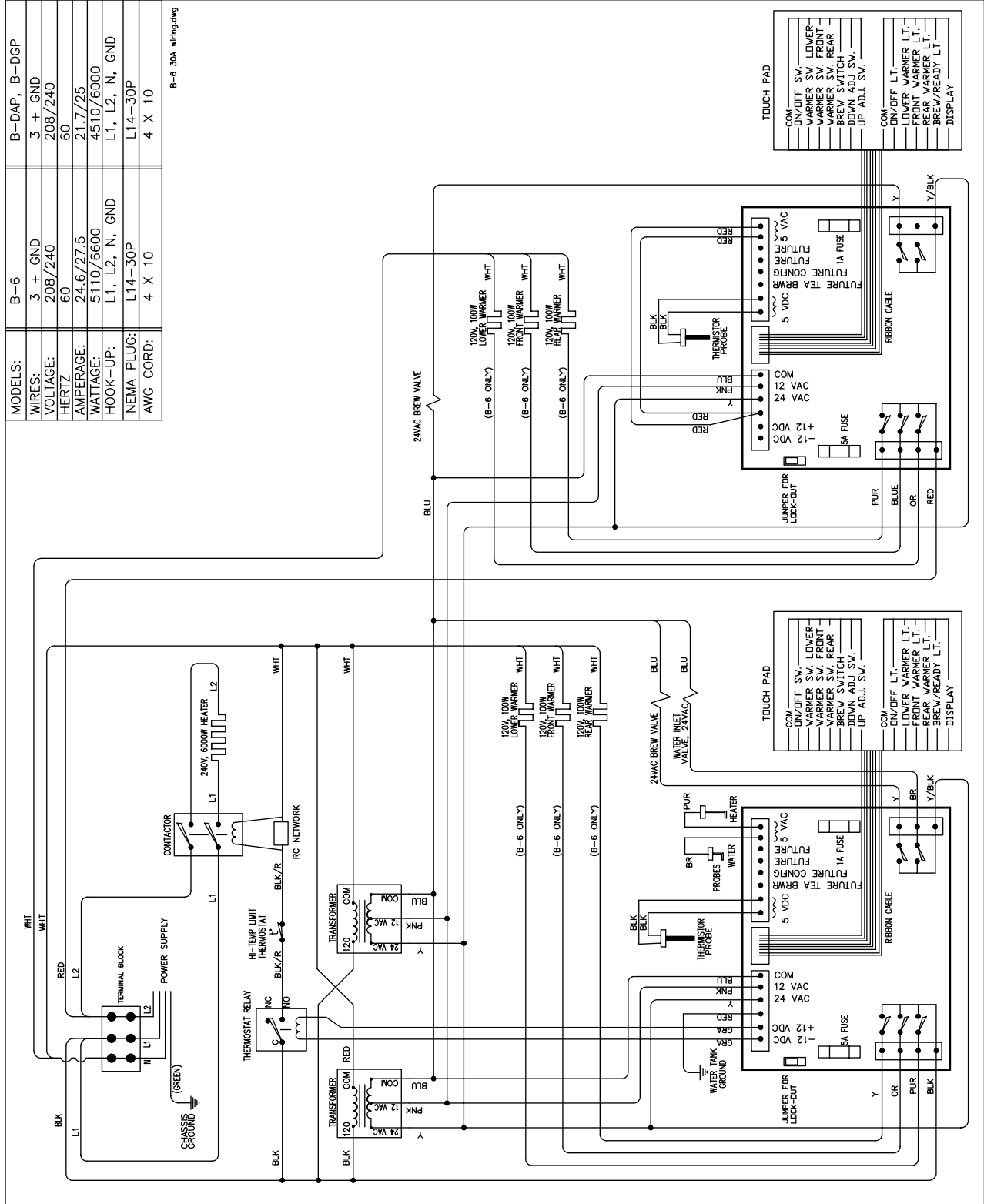



## Wiring Diagram - E Models Models B-6, B-DAP, B-DGP serial numbers A166225 and lower (without a -P suffix)

DOUBLE WIDE BREWER E

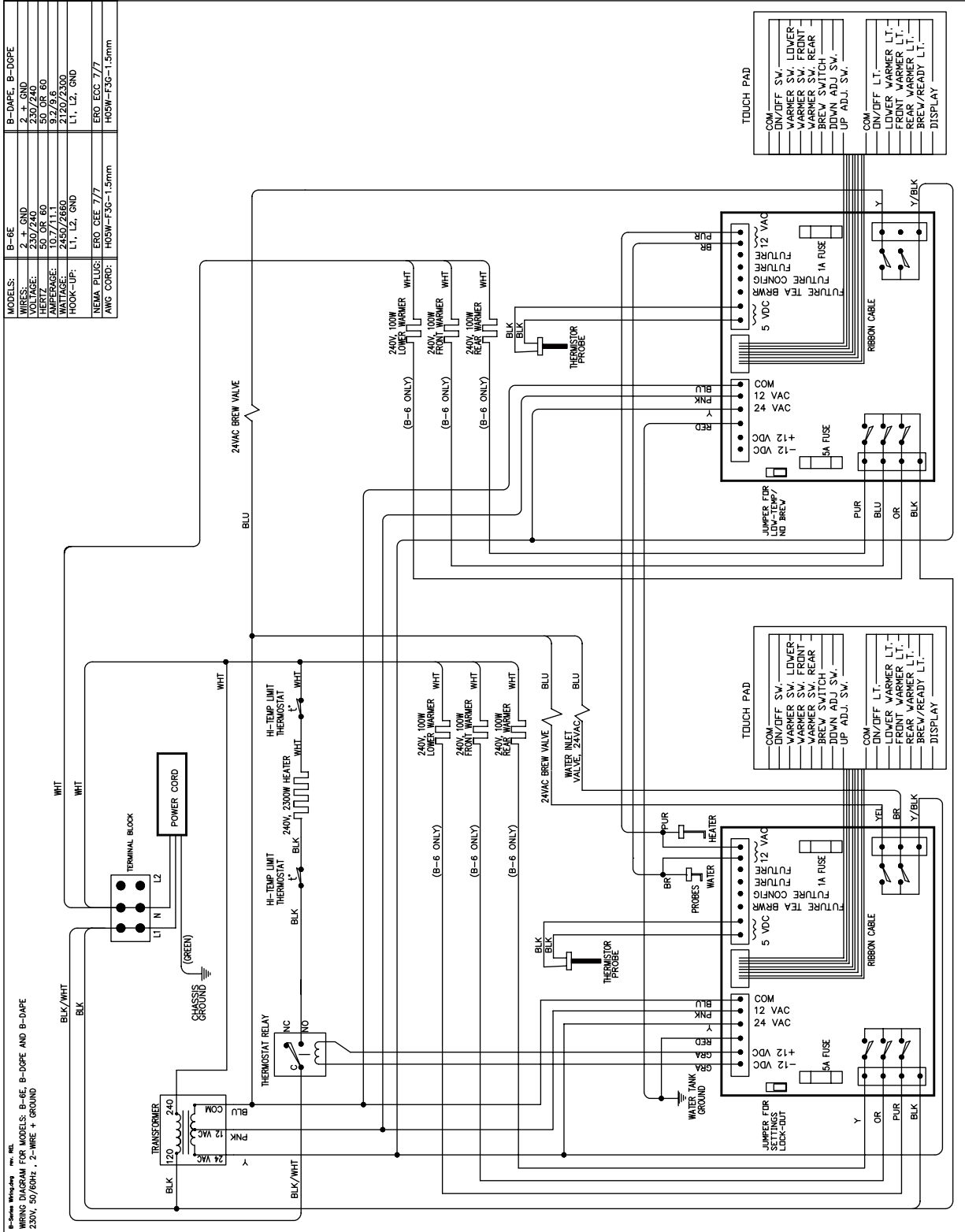

B-Series Wiring Diagram  
WIRING DIAGRAM FOR MODELS B-6E, B-DGPE AND B-DAPE  
230V, 50/60Hz, 1-2-WIRE + GROUND

MODELS:	B-6E	B-DAPE, B-DGPE
WIRES:	2 + GND	2 + GND
VOLTAGE:	230/240	230/240
PHASE:	50/60	50/60
HEIGHT:	80	80
DEPTH:	80	80
WEIGHT:	2450/2860	2120/2300
HOOK-UP:	L1, L2, GND	L1, L2, GND
NEMA PLUG:	ERO GEE 7/7	ERO GEE 7/7
AWG CORD:	HOSW-F3G-1.5mm	HOSW-F3G-1.5mm

## Wiring Diagram

### Models B-3, B-3WR, B-3WL, B-SAP & B-ID serial numbers A166226P and higher (with a -P suffix)

#### DUAL VOLTAGE

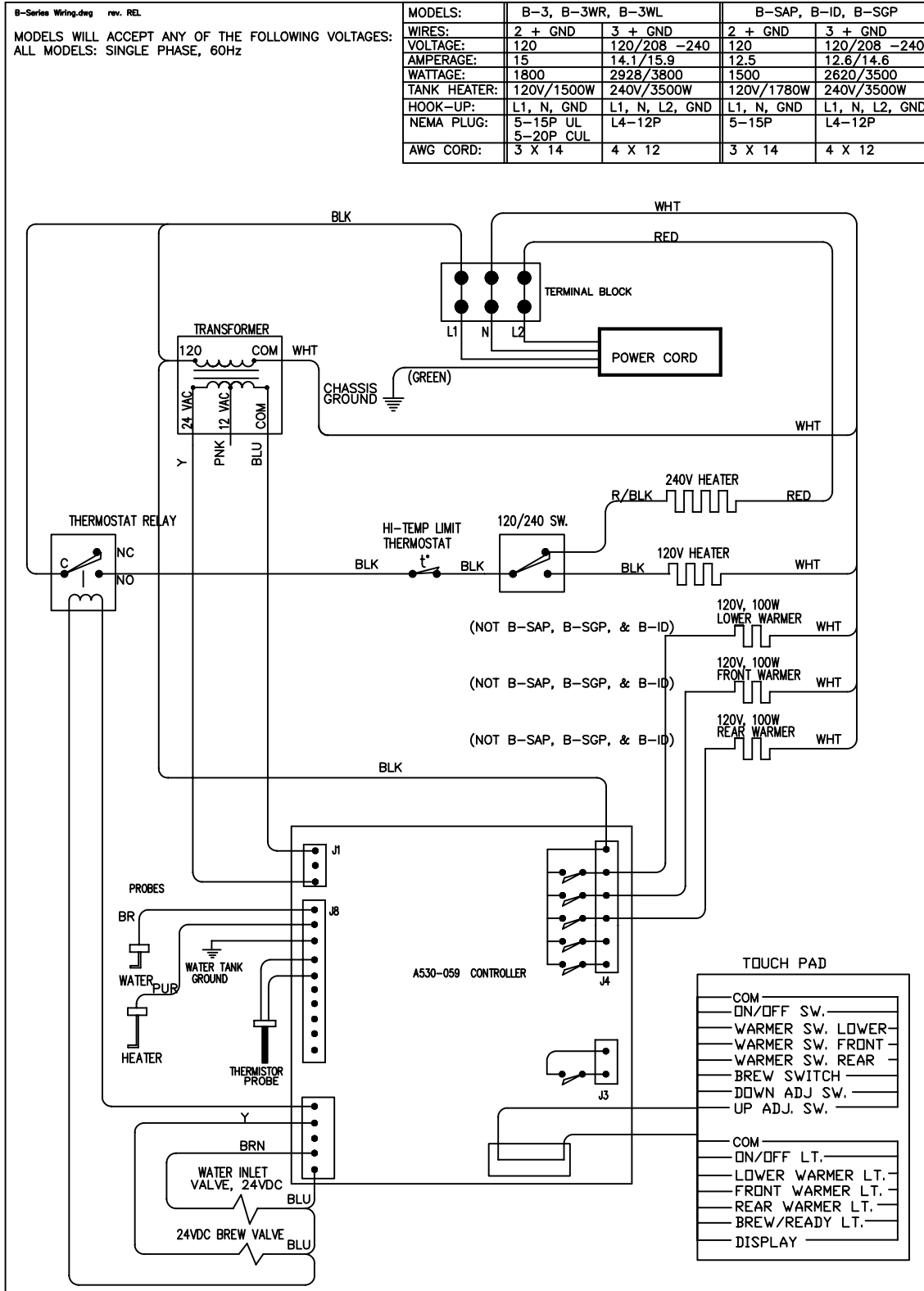



## Wiring Diagram Models B-6, B-DAP, & B-DGP serial numbers A166226P and higher (with a -P suffix)

TWIN HEAD B-SERIES BREWER 120/240V, 30A

MODELS:	B-6	B-DAP, B-DGP
WIRES:	3 + GND	3 + GND
VOLTAGE:	120/208-240	120/208-240
HERTZ:	60	60
AMPERAGE:	24.6/27.5	21.7/25
WATTAGE:	5110/6600	4510/6000
HOOK-UP:	L1, L2, N, GND	L1, L2, N, GND
NEMA PLUG:	L14-30P	L14-30P
AWG CORD:	4 X 10	4 X 10

B-Series Wiring only. See REL.  
WIRING DIAGRAM FOR MODELS: B-6, B-DAP, B-DGP  
120/208-240V, 60Hz, 3-WIRE + GROUND

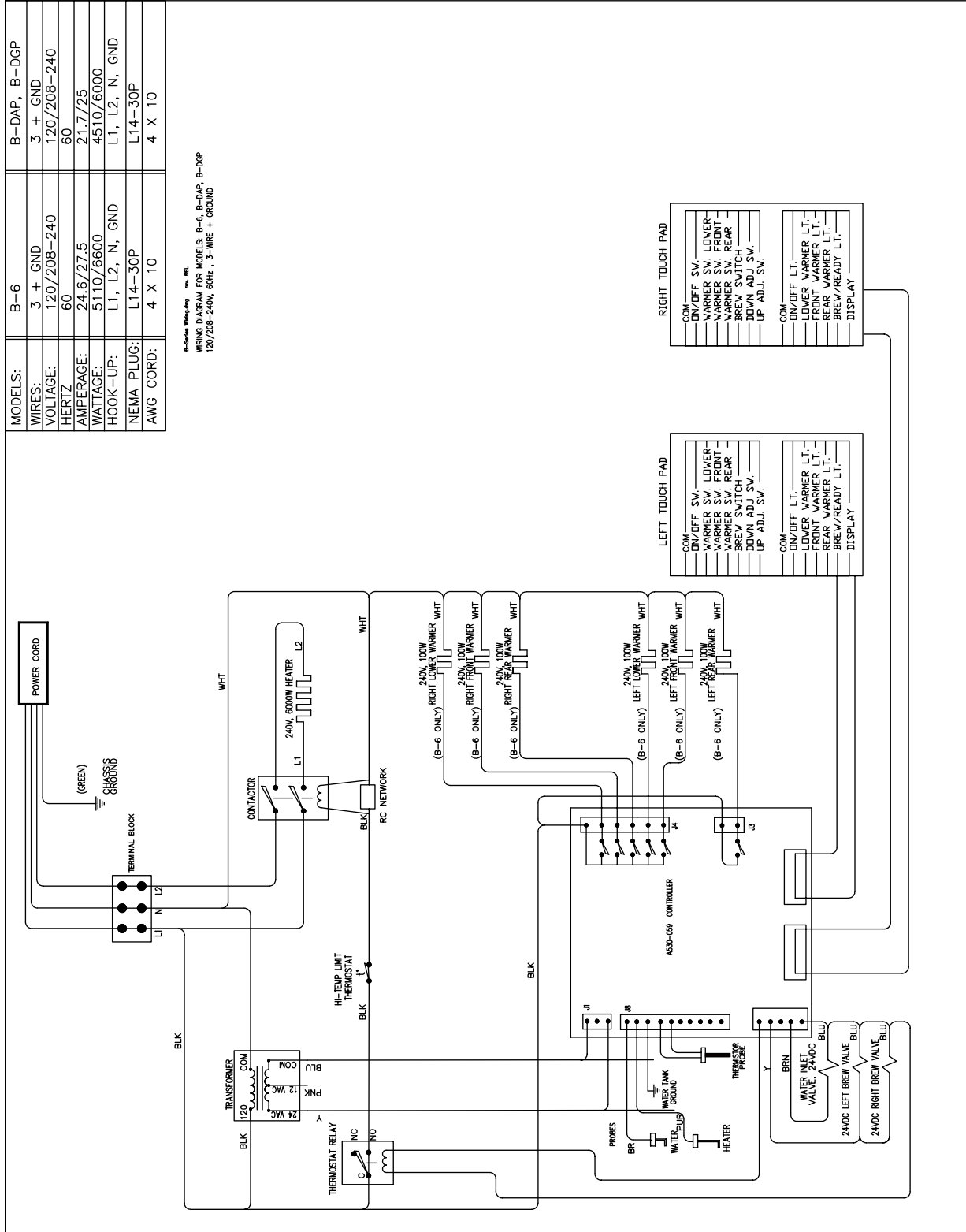

## Wiring Diagram - E Models Models B-6, B-DAP, & B-DGP serial numbers A166226P and higher (with a -P suffix)

DOUBLE WIDE BREWER E

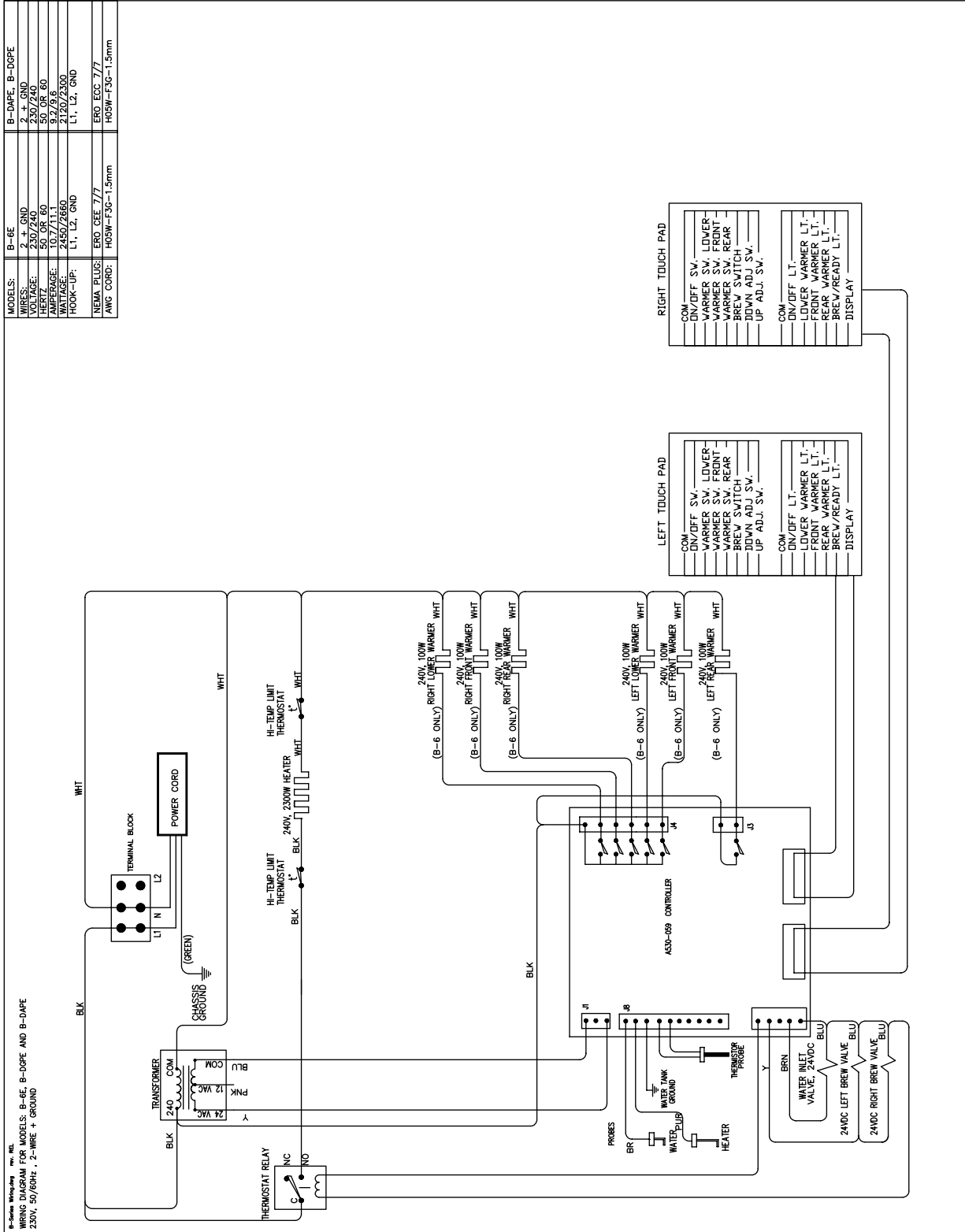







**GRINDMASTER™**

C O R P O R A T I O N

---

Grindmaster® Coffee Grinders and Brewers • PrecisionBrew™ Brewing Systems • Espresso® Espresso Machines  
Crathco® Hot Beverage Dispensers • Crathco® Cold and Frozen Beverage Dispensers • AMW Coffee and Tea Systems  
Tel (502) 425-4776 • Fax (502) 425-4664 • 1-800-695-4500 (USA & Canada only)  
P.O. Box 35020 • Louisville, KY 40232 • USA

© Grindmaster Corporation, 1999  
PRINTED IN USA

[www.grindmaster.com](http://www.grindmaster.com) • email: [info@grindmaster.com](mailto:info@grindmaster.com)

0109 Form # AM-375-08  
Part # 71580