



Whiteboard & Short-throw Projector  
**Universal Mobile Stand**

User's Guide



# Parts List for Universal Mobile Stand

Please make sure all parts listed below are included before proceeding with installation.

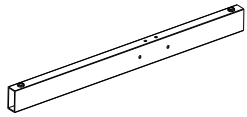

a. Bottom Leg X2

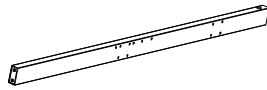

b. Side Leg X2



c. Bottom Center Bar X1

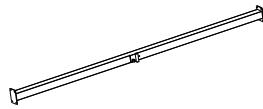

d1. Top Center Bar x1

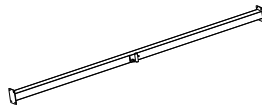

d2. Middle Center Bar x1

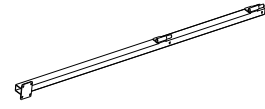

e. Center Upright Bar x1

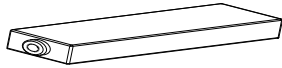

f. Extension Bar x2

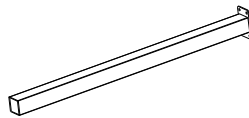

g. Projector Rail x1

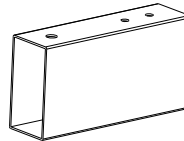

h. Rail Bracket x1



i. Bracket x2

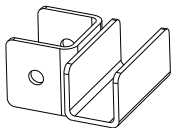

j. Holder x2



k. Wheel x4

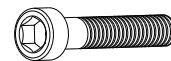

l. M6x15 screw x5

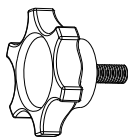

m. M6x20 screw x2

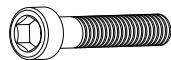

n. M6x35 screw x22



o. M6 Nut x30

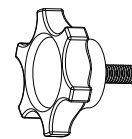

p. M8x20 x3



q. M6 Washer x48

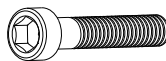

r. M6x60 x4

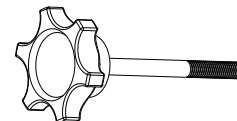

s. M8x50 x1

# Installation Instructions

Elite Screens recommends two persons to fully assemble the Universal Mobile Stand. Please follow the installation instructions carefully and make sure all screws are secure before installing your WhiteBoardScreen Universal to your Universal Mobile Stand.

1. Attach the Wheels (k) to the Bottom Legs (a).
2. Attach the Bottom Legs (a) to the Side Legs (b) and secure with the M6x60 screws (r), M6 washers (q), and M6 nuts (o).
3. Attach the Bottom Center Bar (c) as shown in the figure below and secure with the M6x35 screws (n), M6 washers (q) and M6 nuts (o).
4. The installation should look like the illustration below.

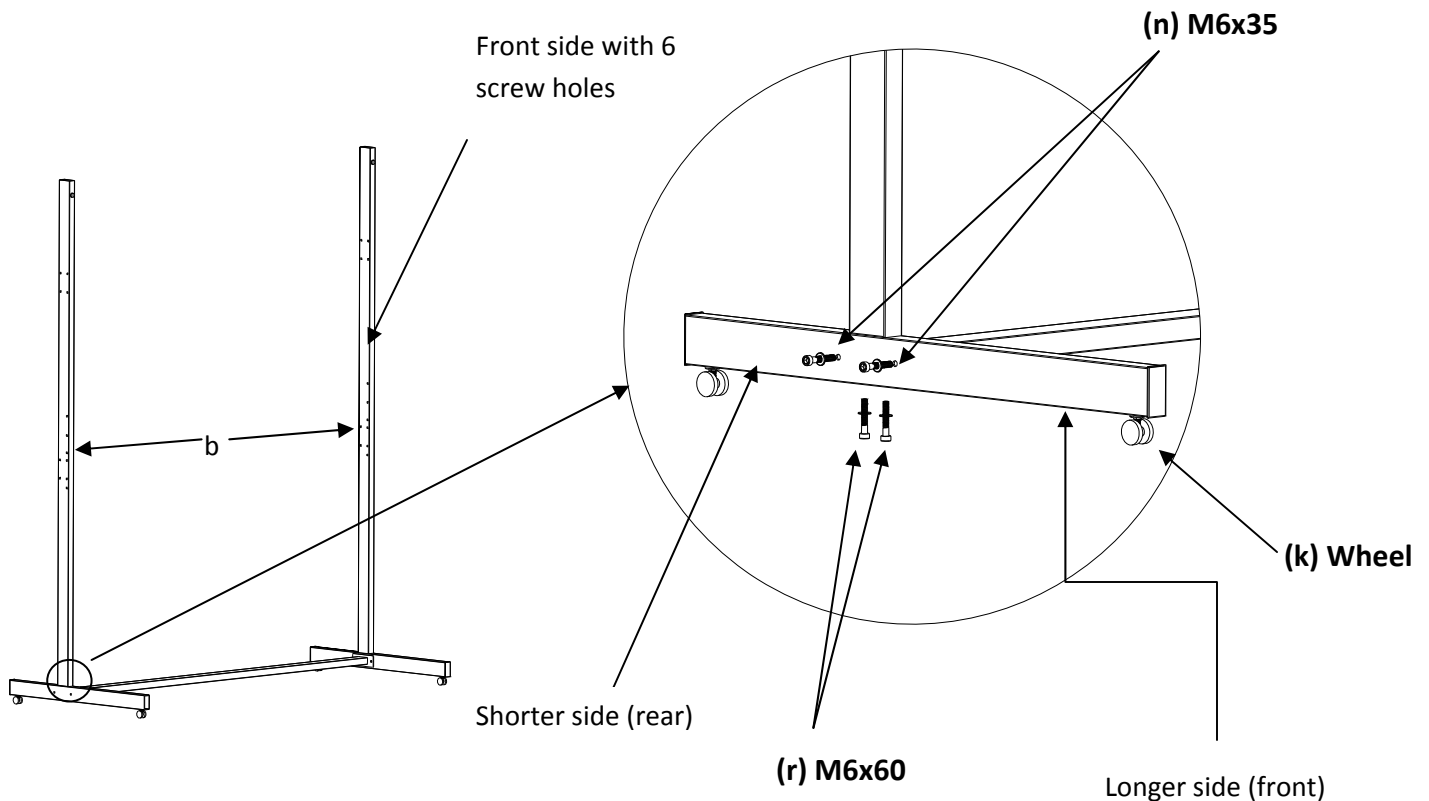

5. Attach the Top Center Bar (d1) and the Middle Center Bar (d2) to the Side Legs (b), and secure with M6x35 screws (n), M6 washers (q) and M6 nuts (o).
6. Insert the Extension Bars (f) to the side legs, attach the brackets (i) and secure with the M6x20 screws (m). Make sure the brackets are facing the front of the stand.
7. Attach the Holders (j) to the side legs and secure with M6x35 screws (n), M6 washers (q) and M6 nuts (o).

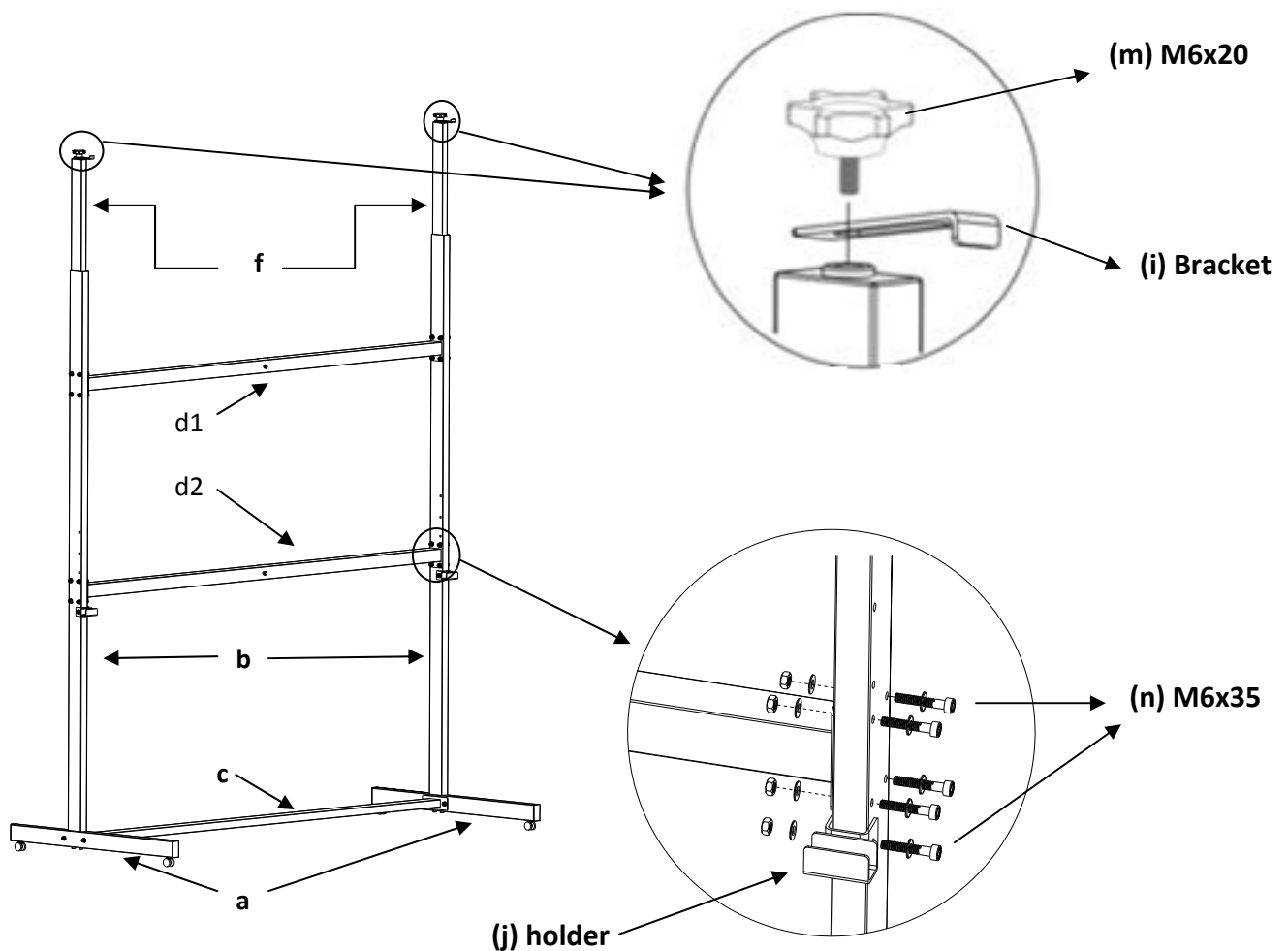

8. Attach the Projector Rail (g) to the Center Upright Bar (e) and secure with M6x15 screws (l), M6 washers (q) and M6 nuts (o).
9. Attach the Center Upright Bar (e) to the Middle Center Bar (d2) and to the Top Center Bar, and secure with the M8x50 screw (s).
10. Attach the Rail Bracket (h) to the projector mount and to the Projector Rail (g), and secure with the M8x20 screw (p).

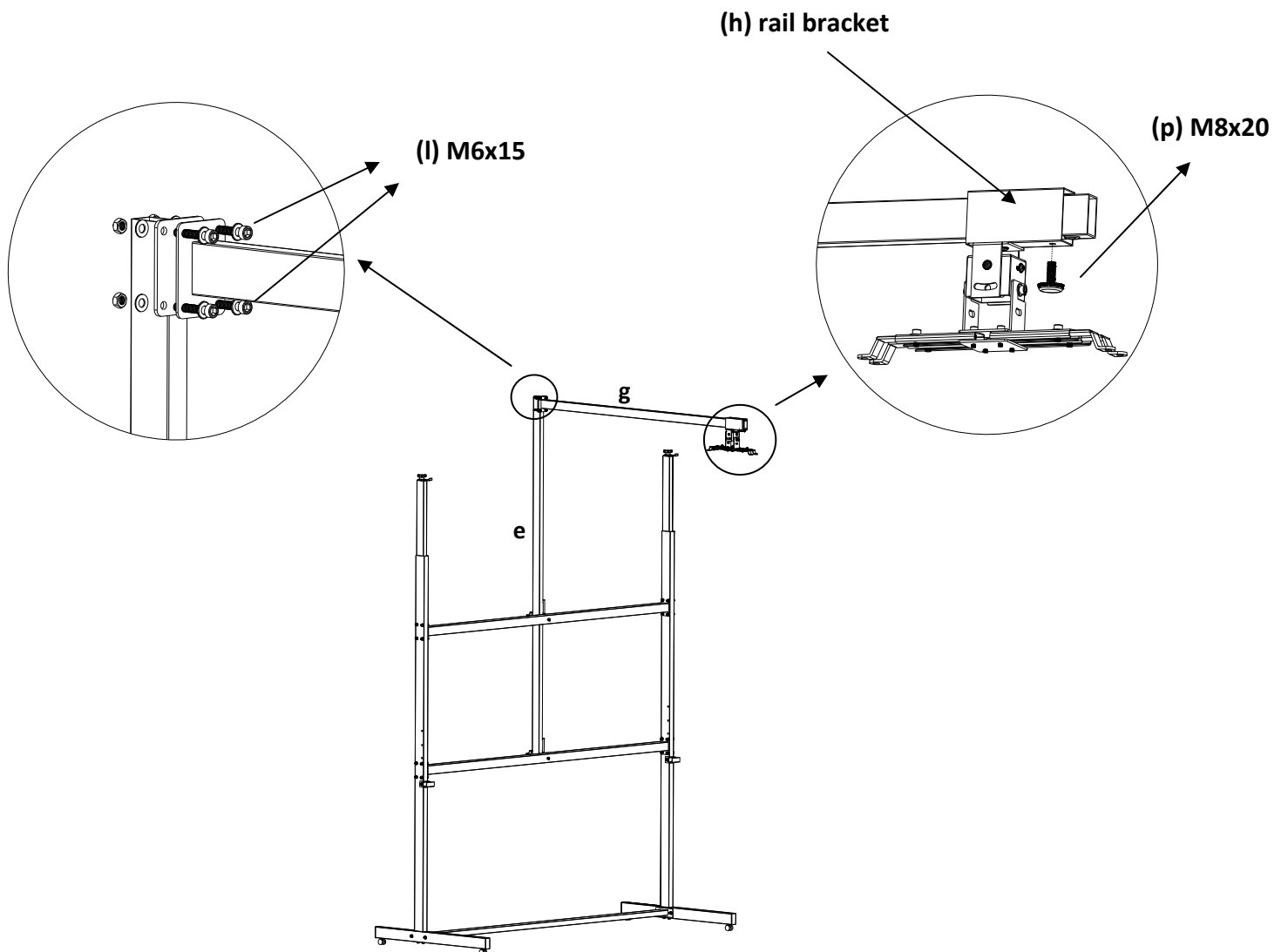

11. Secure the Extension Bars (f) with M8x20 screws (p).

(p) M8x20

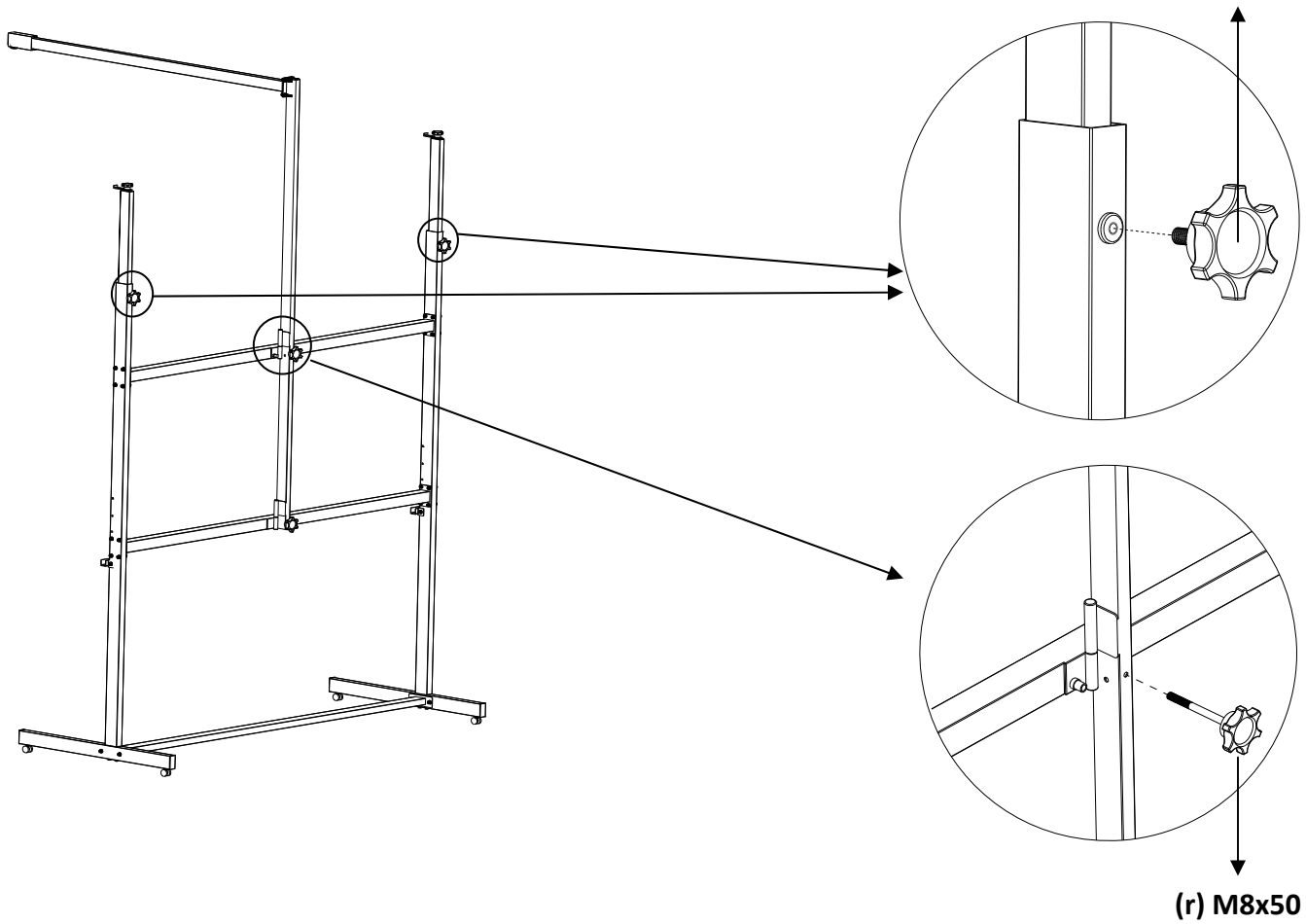

(r) M8x50

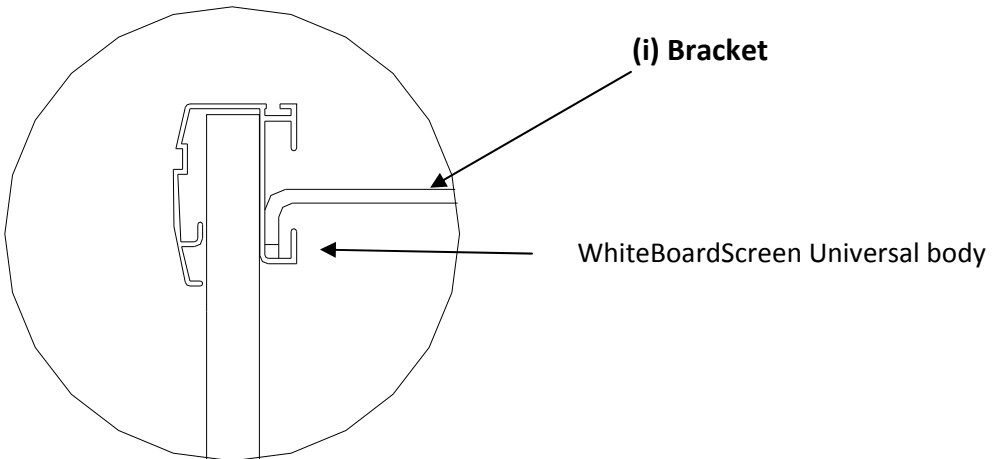

# Universal Mobile Stand Dimensions

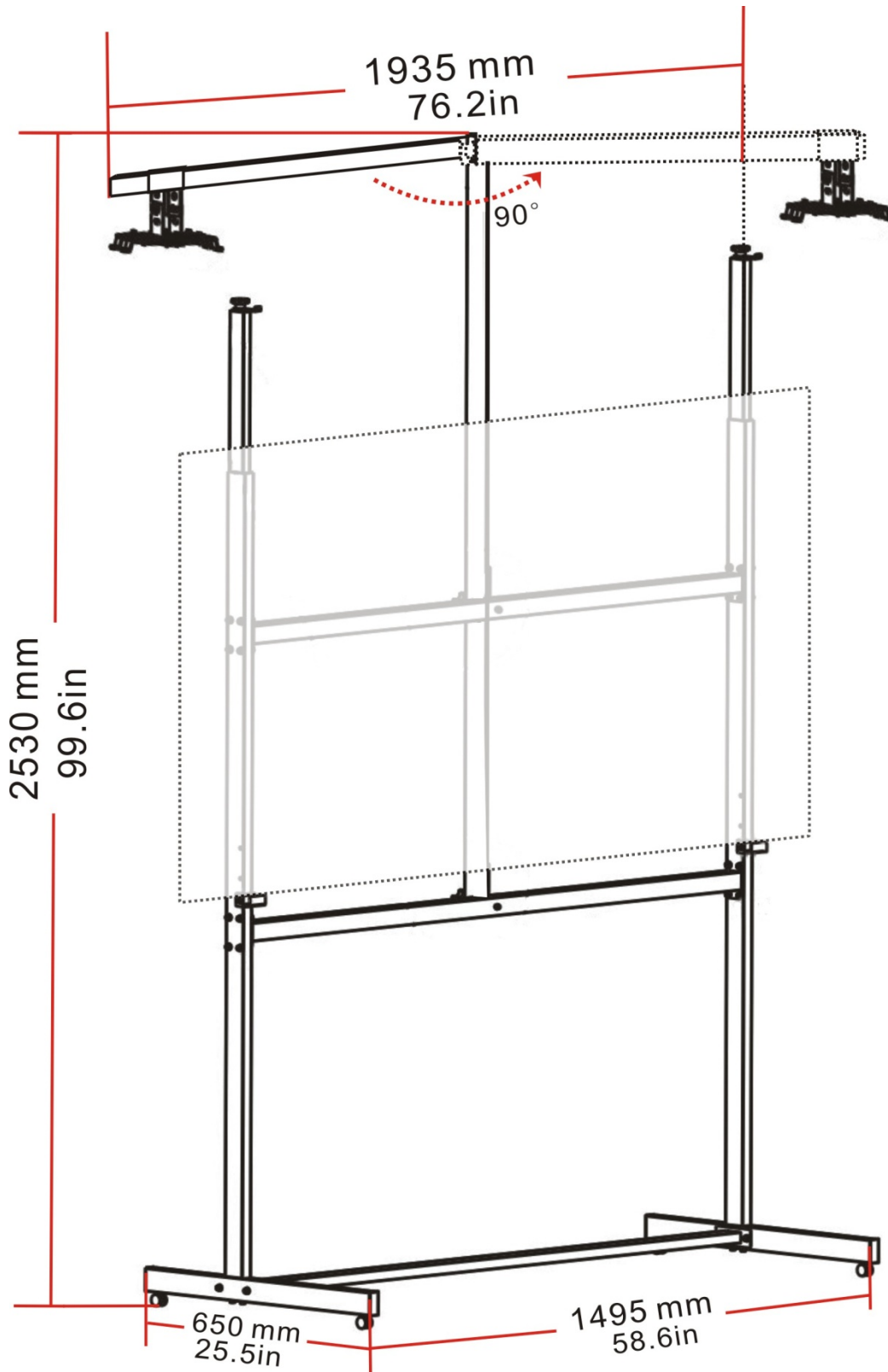

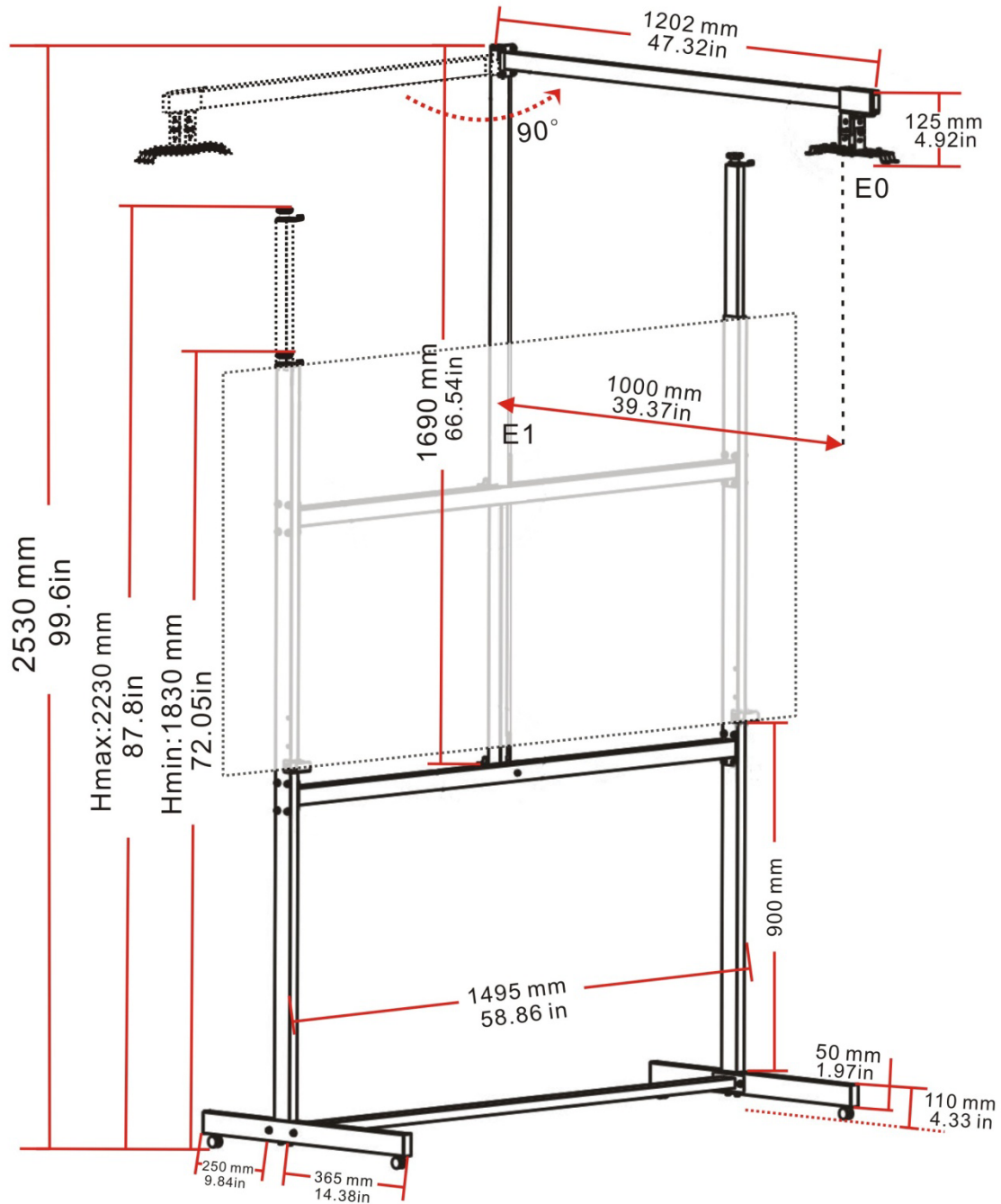



# Warranty Policy

- **Two (2) Year** parts and labor warranty from defects in workmanship from purchase date as follows (except for refurbished units as specified below).
- **Three (3) Year** parts and labor warranty from defects in workmanship for **GEMR** (Government, Educational, Military, & Religious) purchases of new product only.
- **Refurbished Units** carry a **90-DAY** parts and labor warranty.
- Each party will be responsible for one way shipping during the warranty period.
- A **RMA (Return Merchandise Authorization) number** must be issued in order to process a replacement or to authorize a return for warranty repair. Elite Screens will, at its sole option replace or repair the defective unit with a replacement \*(see exceptions below) after the defective unit or parts have been received. Once the product is received, Elite Screens will send out a replacement \*unit to the customer by ground service (subject to inventory availability).
- **Do Not Return Any Unauthorized Items to Elite Screens, as they will be refused and returned at your expense. The RMA Number must be included on the outside label of your shipping box. Our warehouse is not authorized to accept returns without an RMA number on the shipping label.**
- **RMA Numbers are valid for 45 days from the date issued.**
- **Missing Parts** must be reported within 7 days of receipt. If reported after 7 days, the customer will be responsible for shipping and handling fees. If reported after 30 days of receipt, the customer will be responsible for cost of parts and shipping & handling fees.

\*A New or refurbished replacement will be send out to the customer depending on the type of purchase (new or refurbished) and based on stock availability.

## North America only U.S. and Canada

For Warranty and Service requests, please submit an RMA/Service Form at:  
[www.elitescreens.com/warrantysupportform](http://www.elitescreens.com/warrantysupportform)

Please visit this link for full Warranty information:  
[www.elitescreens.com/warranty](http://www.elitescreens.com/warranty)

For Customer Service and Technical questions, please contact Elite Screens at:  
Telephone: (877) 511-1211 [service@elitescreens.com](mailto:service@elitescreens.com)  
Fax: (562) 926-8433 [techsupport@elitescreens.com](mailto:techsupport@elitescreens.com)

**REMEMBER TO REGISTER YOUR PRODUCT AT:**

[www.elitescreens.com](http://www.elitescreens.com)

# Contact Info

US & Canada Tech Support & Warranty Claim

Please contact us at [service@elitescreens.com](mailto:service@elitescreens.com) or call +1 877-511-1211 #3 or fax +1-562-926-8433

Europe Tech Support & Warranty Claim

Please contact us at [service@elitescreens.eu](mailto:service@elitescreens.eu) or call +49-(0) 40-30392958

Asia Tech Support & Warranty Claim

Please contact us at [service@elitescreens.com.cn](mailto:service@elitescreens.com.cn) or call +86-(0) 755-8461-7989

Taiwan Tech Support & Warranty Claim

Please contact us at [service@elitescreens.com.tw](mailto:service@elitescreens.com.tw) or call +866+2+8990-1999

## America:

### Elite Screens Inc

16410 Manning Way  
Cerritos, CA 90703 USA  
Tel: +1-877-511-1211  
Fax: +1-562-926-8433  
[info@elitescreens.com](mailto:info@elitescreens.com)  
[www.elitescreens.com](http://www.elitescreens.com)

## Europe:

### Elite Screens Europe

Lübecker Straße 1  
22087 Hamburg, Germany  
Tel: +49-4030392494  
Fax: +49-40-49219200  
[info@elitescreens.eu](mailto:info@elitescreens.eu)  
[www.elitescreens.eu](http://www.elitescreens.eu)

## Asia:

### Elite Screens China Corp.

Longxi Duimianling Industry Zone  
Longcheng Longgang District,  
ShenZhen Guangdong, China  
Tel: +86-(0)755-8461-7989  
Fax: +86-(0)755-8461-7669  
[info@elitescreens.com.cn](mailto:info@elitescreens.com.cn)  
[www.elitescreens.com.cn](http://www.elitescreens.com.cn)

## Elite Screens France S.A.S

11, Allée William Penn  
92150 Suresnes, France  
Tel: +33-1-45064735  
Fax: +33-1-45064735  
[info.fr@elitescreens.com](mailto:info.fr@elitescreens.com)  
[www.elitescreens.com/fr](http://www.elitescreens.com/fr)

## Taiwan:

### Elite Screens Taiwan Corp.

4F., No. 42-1 Wuguan Rd. Wugu Township Taipei  
County 248, Taiwan (Wugu Industrial Park)  
Taiwan (R.O.C)  
Tel: +886+2+8990-1999  
Fax: +886+2+8990+1366  
[info@elitescreens.com.tw](mailto:info@elitescreens.com.tw)  
[www.elitescreens.com.tw](http://www.elitescreens.com.tw)

## Japan:

### Elite Screens Japan Corp.

467-2-606 Tsuruma, Machida-shi,  
Tokyo, 194-0004 Japan  
Tel: 0120-07-0008  
Fax: +81(0)42-706-9130  
[info@elitescreens.jp](mailto:info@elitescreens.jp)  
[www.elitescreens.jp](http://www.elitescreens.jp)

## Latin America Contact:

[Info.la@elitescreens.com](mailto:Info.la@elitescreens.com)

## East Asia Contact:

[Info.ea@elitescreens.com](mailto:Info.ea@elitescreens.com)

## India Contact:

[Info.ea@elitescreens.com](mailto:Info.ea@elitescreens.com)