

3/4" CAPACITY IMPACT WRENCH

Model: WG068A-F4-()

NOTICE

The ARO WG068A-F4 3/4" Impact Wrench is designed for use in the construction industry and in the production of heavy equipment such as locomotive, bulldozers, tractors and ships.

ARO is not responsible for customer modification of tools for applications on which ARO was not consulted.

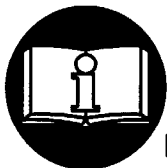

WARNING

**IMPORTANT SAFETY INFORMATION ENCLOSED.
READ THIS MANUAL BEFORE OPERATING TOOL.**

**IT IS THE RESPONSIBILITY OF THE EMPLOYER TO PLACE THE INFORMATION
IN THIS MANUAL INTO THE HANDS OF THE OPERATOR.
FAILURE TO OBSERVE THE FOLLOWING WARNINGS COULD RESULT IN INJURY.**

PLACING TOOL IN SERVICE

- Always operate, inspect and maintain this tool in accordance with American National Standards Institute Safety Code for Portable Air Tools (ANSI B186.1)
- For safety, top performance, and maximum durability of parts, operate this tool at 90 psig (6.2 bar/620 kPa) maximum air pressure at the inlet with 3/4" (19 mm) inside diameter air supply hose.
- Always turn off the air supply and disconnect the air supply hose before installing, removing or adjusting any accessory on this tool, or before performing any maintenance on this tool.
- Do not use damaged, frayed or deteriorated air hoses and fittings.
- Be sure all hoses and fittings are the correct size and are tightly secured. See Dwg. TPD905-1 for a typical piping arrangement.
- Always use clean, dry air at 90 psig (6.2 bar/620 kPa) maximum air pressure. Dust, corrosive fumes and/or excessive moisture can ruin the motor of an air tool.
- Do not lubricate tools with flammable or volatile liquids such as kerosene, diesel or jet fuel.
- Do not remove any labels. Replace any damaged label.

USING THE TOOL

- Always wear eye protection when operating or performing maintenance on this tool.

- Always wear hearing protection when operating this tool.
- Keep hands, loose clothing and long hair away from rotating end of tool.
- Note the position of the reversing lever before operating the tool so as to be aware of the direction of rotation when operating the throttle.
- Anticipate and be alert for sudden changes in motion during start up and operation of any power tool.
- Keep body stance balanced and firm. Do not over-reach when operating this tool. High reaction torques can occur at or below the recommended air pressure.
- Tool shaft may continue to rotate briefly after throttle is released.
- Air powered tools can vibrate in use. Vibration, repetitive motions or uncomfortable positions may be harmful to your hands and arms. Stop using any tool if discomfort, tingling feeling or pain occurs. Seek medical advice before resuming use.
- Use accessories recommended by ARO.
- Use only impact sockets and accessories. Do not use hand (chrome) sockets or accessories.
- Impact wrenches are not torque wrenches. Connections requiring specific torque must be checked with a torque meter after fitting with an impact wrench.
- This tool is not designed for working in explosive atmospheres.
- This tool is not insulated against electric shock.

NOTICE

The use of other than genuine ARO replacement parts may result in safety hazards, decreased tool performance, and increased maintenance, and may invalidate all warranties.

Repairs should be made only by authorized trained personnel. Consult your nearest ARO Tool Products Authorized Servicenter.

For parts and service information, contact your local ARO distributor, or the Customer Service Dept. of the Ingersoll-Rand Distribution Center, White House, TN at PH: (615) 672-0321, FAX: (615) 672-0601

ARO Tool Products

Ingersoll-Rand Company

1725 U.S. No. 1 North • P.O. Box 8000 • Southern Pines, NC 28388-8000

©1996 INGERSOLL-RAND COMPANY • PRINTED IN U.S.A.

ARO

Part of worldwide Ingersoll-Rand

WARNING LABEL IDENTIFICATION

▲ WARNING

FAILURE TO OBSERVE THE FOLLOWING WARNINGS COULD RESULT IN INJURY.

| | |
|---|---|
|  | ▲ WARNING |
| | Always wear eye protection when operating or performing maintenance on this tool. |

| | |
|--|--|
|  | ▲ WARNING |
| | Always wear hearing protection when operating this tool. |

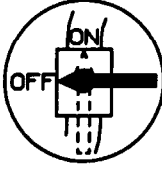
| | |
|---|---|
|  | ▲ WARNING |
| | Always turn off the air supply and disconnect the air supply hose before installing, removing or adjusting any accessory on this tool, or before performing any maintenance on this tool. |

| | |
|--|--|
|  | ▲ WARNING |
| | Air powered tools can vibrate in use. Vibration, repetitive motions or uncomfortable positions may be harmful to your hands and arms. Stop using any tool if discomfort, tingling feeling or pain occurs. Seek medical advice before resuming use. |

| | |
|---|------------------------------------|
|  | ▲ WARNING |
| | Do not carry the tool by the hose. |

| | |
|--|--|
|  | ▲ WARNING |
| | Do not use damaged, frayed or deteriorated air hoses and fittings. |

| | |
|---|--|
|  | ▲ WARNING |
| | Keep body stance balanced and firm. Do not overreach when operating this tool. |

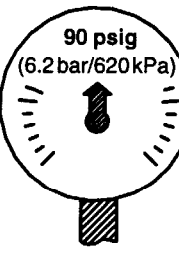
| | |
|--|--|
|  | ▲ WARNING |
| | Operate at 90 psig (6.2 bar/620 kPa) Maximum air pressure. |

PLACING TOOL IN SERVICE

LUBRICATION



IRAX No. 50



IRAX No. 100

Always use an air line lubricator with these tools.
We recommend the following Filter-Lubricator-Regulator Unit:

For USA – IRAX No. C31-06-G00

For International – IRAX No. FRL30-C6-A29

After each eight hours of operation, unless an air line lubricator is used, inject approximately 1 to 2 cc of IRAX No. 50 Oil into the air inlet before attaching the air hose.

After each forty-eight hours of operation, or as experience indicates, inject about 4 cc of IRAX No. 100 Grease into the Grease Fitting (12).

INSTALLATION

Air Supply and Connections

Use clean, dry air at 90 psig maximum. Dust, corrosive fumes and/or excessive moisture can ruin the motor of an air tool. An air line filter can greatly increase the life of an air tool. The filter removes dust and moisture.

Be sure all hoses and fittings are the correct size and are tightly secured. See Dwg. TPD905-1 for a typical piping arrangement.

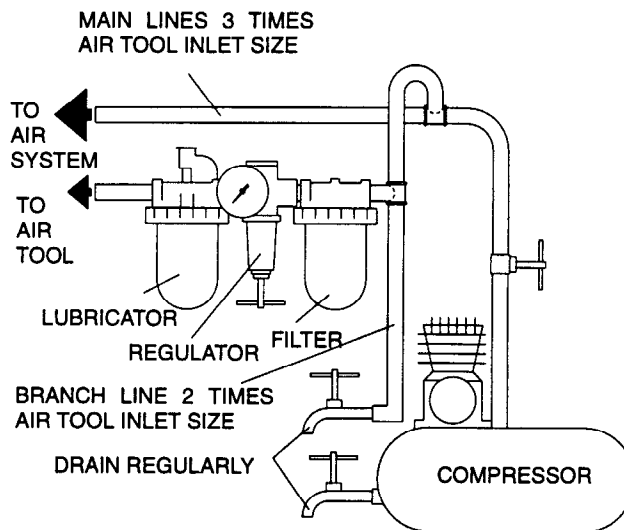

HOW TO ORDER AN IMPACT WRENCH

PISTOL GRIP with 3/4" SQUARE DRIVE

| Model | Impacts/min. | Recommended Torque Range | |
|-----------|--------------|--------------------------|---------|
| | | ft-lb | Nm |
| WG068A-F4 | 1 000 | 200-600 | 271-813 |

MAINTENANCE SECTION

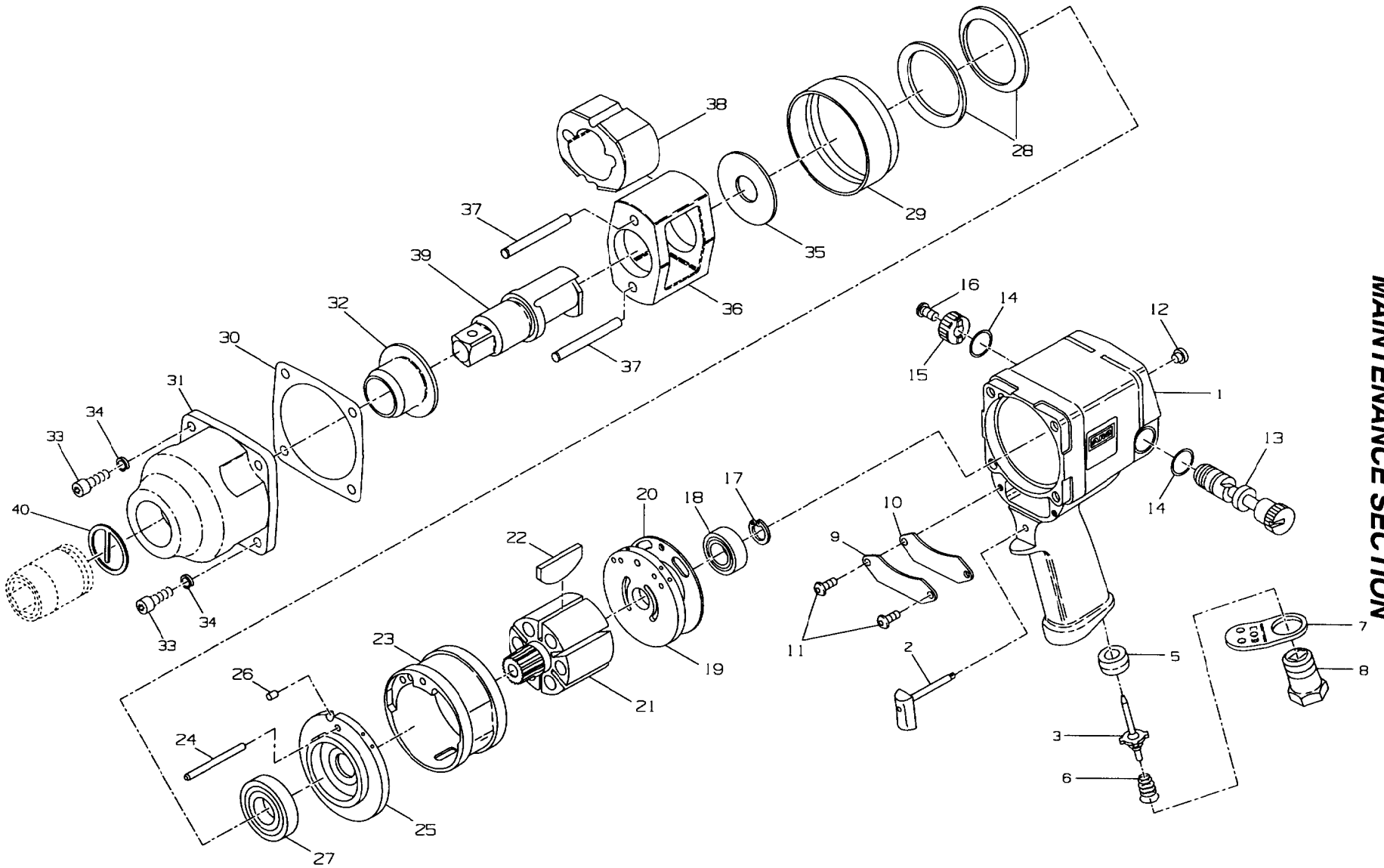

4

PART NUMBER FOR ORDERING

PART NUMBER FOR ORDERING

| | | | | | |
|----|---------------------------------------|------------|----|---|--------------|
| 1 | Motor Housing Assembly | VW-1083 | 28 | Motor Clamp Washer (2) | 2920-207 |
| 2 | Trigger Assembly | 2920P-A93 | 29 | Motor Retainer | 2920B-800 |
| ◆ | 3 Throttle Valve | DG230-302 | ◆ | 30 Hammer Case Gasket | 910-36 |
| ◆ | 5 Throttle Valve Seat | DG230-303 | 31 | Hammer Case Assembly | |
| ◆ | 6 Throttle Valve Spring | 1720P-51 | | for models ending in -EU | VW-1086-EU |
| 7 | Exhaust Deflector | 1720P-23 | | for all other models | VW-1086 |
| 8 | Inlet Bushing | 2920P-465 | 32 | Hammer Case Bushing | 2920-641 |
| 9 | Housing Plate | 1720P-230 | * | Hammer Case Label | |
| ◆ | 10 Housing Plate Gasket | 1720P-231 | | for models ending in -EU | EU-99 |
| 11 | Housing Plate Screw (2) | FEA100-112 | | for all other models | WARNING-2-99 |
| 12 | Grease Fitting | 130SR-188 | 33 | Hammer Case Cap Screw (4) | 34U-103 |
| 13 | Reverse Valve | 1710B-329 | 34 | Cap Screw Lock Washer (4) | T11-58 |
| ◆ | 14 Reverse Valve Seal (2) | 261-283 | 35 | Rear Hammer Frame Washer | 910-706 |
| 15 | Reverse Valve Knob | 231-666 | 36 | Hammer Frame Assembly | 2910-A703 |
| 16 | Reverse Valve Knob Screw | 231-665 | 37 | Hammer Pin (2) | 2910-704 |
| ◆ | 17 Rear Rotor Bearing Retainer | MVA008-218 | 38 | Hammer | 260-724 |
| ◆ | 18 Rear Rotor Bearing | 4E-510 | 39 | Anvil | 260-726 |
| 19 | Rear End Plate | 2920-12 | 40 | Socket Retainer | RR10034S |
| ◆ | 20 Rear End Plate Gasket | 2920B-283 | * | Horizontal Hanger | 910-366 |
| 21 | Rotor | 2910B-53 | * | Nameplate | |
| ◆ | 22 Vane Packet (set of 6 Vanes) | 2910-42-6 | | for models ending in -EU | VW-1087-EU |
| 23 | Cylinder | 2920-3 | | for all other models | VW-1087 |
| 24 | Cylinder Dowel | 910-98 | * | Tune-up Kit (includes illustrated parts | |
| 25 | Front End Plate | 2920-11 | | 3, 5, 6, 10, 14 [2], 17, 18, 20, 22, | |
| 26 | End Plate Dowel | 2920-74 | | 27, and 30) | 1720P-TK2 |
| ◆ | 27 Front Rotor Bearing | 834-24 | | | |

* Not illustrated.

◆ Indicates Tune-up Kit Part.

MAINTENANCE SECTION

MAINTENANCE SECTION

WARNING

Always wear eye protection when operating or performing maintenance on this tool.

Always turn off the air supply and disconnect the air supply hose before installing, removing or adjusting any accessory on this tool, or before performing any maintenance on this tool.

LUBRICATION

Each time a WG068A-F4 Impact Wrench is disassembled for maintenance and repair or replacement of parts, lubricate the tool as follows:

1. Work approximately 12 to 15 cc of IRAX No. 100 Grease into the impact mechanism, particularly around the Hammer Pins (37), Hammer (38), Hammer Frame (36), Anvil (39) and inside the Hammer Case Bushing (32).
2. Work some IRAX No. 100 Grease into the Rear Rotor Bearing (18) and Front Rotor Bearing (27).
3. Inject approximately 4 cc of IRAX No. 100 Grease into the Grease Fitting (12).
4. Wipe a thin film of IRAX No. 50 Oil on the Rotor (21), Vanes (22), Reverse Valve (13), Rear End Plate (19), Front End Plate (25) and the bore of the Cylinder (23).
5. Use IRAX No. 50 Oil for lubrication the motor. Inject approximately 1 to 2 cc of oil into the air inlet before attaching the air hose.

DISASSEMBLY

General Instructions

1. Do not disassemble the tool any further than necessary to replace or repair damaged parts.
2. Whenever grasping a tool or part in a vise, always use leather-covered or copper-covered vise jaws to protect the surface of the part and help prevent distortion. This is particularly true of threaded members and housings.
3. Do not remove any part which is a press fit in or on a subassembly unless the removal of that part is necessary for repairs or replacement.
4. Do not disassemble the tool unless you have a complete set of new gaskets and O-rings for replacement.
2. Slide assembled motor out of Motor Housing.

Disassembly of the Impact Wrench

1. Clamp the handle of the tool in leather-covered or copper-covered vise jaws with the square driver upward.

* Registered trademark of Loctite Corporation.

2. Unscrew and remove the four Hammer Case Cap Screws (33).
3. While lightly tapping on the end of the Anvil (39) with a plastic hammer, lift off the Hammer Case (31) and remove the Hammer Case Gasket (30).
4. Grasp the Hammer Frame (36) and carefully lift off the entire impact mechanism, making certain not to drop the two Hammer Pins (37).

Disassembly of the Impact Mechanism

1. Set the mechanism, driver end up, on the workbench. Using a felt tipped pen, mark one end of the Hammer “↑” with the arrow pointing upward.
2. With the mechanism sitting upright on the workbench, slowly rotate the Anvil in a clockwise direction until it comes up solid.

NOTICE

If you continue to rotate the Anvil, it will cam the Hammer out of engagement. Don't do this; merely rotate the Anvil until it comes up solid.

3. Hold the Hammer Frame (38) firmly and, without disturbing the Hammer, gently lift the Anvil from the Hammer Frame.
4. With the Anvil removed, lift out the two Hammer Pins (37).

NOTICE

The Hammer is now free to slide from the Hammer Frame. Be careful not to drop it.

Disassembly of the Reverse Valve

1. Unscrew the Reverse Valve Knob Screw (16) and remove the Reverse Valve Knob (15).

NOTICE

This Screw is installed with Loctite®*. You may have to heat the Screw slightly to loosen it.

2. While slowly rotating the Reverse Valve (13), withdraw it from the reverse valve bushing in the Motor Housing. Remove the Housing from the vise.

Disassembly of the Motor

1. Grasp the Motor Retainer (29) and lift it from the Motor Housing (1).
2. Lift the Rear Hammer Frame Washer (35) and the two Motor Clamp Washers (28) from the front of the motor.
3. Grasping the spline of the Rotor (21), carefully lift the assembled motor from the Motor Housing.

MAINTENANCE SECTION

NOTICE

The End Plate Dowel (26) will be free to move when the the Front End Plate (25) clears the Housing. Do not lose it.

4. Remove the Rear End Plate Gasket (20).
5. Slide the Front End Plate and Front Rotor Bearing (27) from the Rotor.
6. Remove the Cylinder Dowel (24), Cylinder (23) and Vanes (22) from the Rotor.
7. Using snap ring pliers, remove the Rear Rotor Bearing Retainer (17) and slide the Rear End Plate (19) and Rear Rotor Bearing (18) from the Rotor.
8. If the Front Rotor Bearing or Rear Rotor Bearing requires replacement, press it from the End Plate with an arbor press.

Disassembly of the Throttle Mechanism

1. Unscrew the Inlet Bushing (8) and remove the Exhaust Deflector (7), Throttle Valve Spring (6) and the Throttle Valve (3).

NOTICE

The Trigger (2) will be free to fall out of the Housing when the Throttle Valve is removed. Do not lose it.

2. If the Throttle Valve Seat (5) requires replacement, insert a hooked tool through the center of the Valve Seat. Catching the backside of the Seat with the hook, pull the Seat from the Housing.
3. Remove the two Housing Plate Screws (11) and the Housing Plate (9) if the Housing Plate Gasket (10) needs to be replaced.

ASSEMBLY

General Instructions

1. Always press on the **inner** ring of a ball-type bearing when installing the bearing on a shaft.
2. Always press on the **outer** ring of a ball-type bearing when pressing the bearing into a bearing recess.
3. Whenever grasping a tool or part in a vise, always use leather-covered or copper-covered vise jaws. Take extra care with threaded parts and housings.
4. Always clean every part and wipe every part with a thin film of oil before installation.

** Registered trademark of ND Industries.

5. Apply a film of O-ring lubricant to all O-rings before final assembly.

Assembly of the Throttle Mechanism

1. If the Housing Plate (9) was removed, position the Housing Plate Gasket (10) and Housing Plate, convex side first, against the Motor Housing (1). Apply Vibra-Tite®** to the two Housing Plate Screws (11) and secure the Plate and the Gasket with the Screws. Tighten the Screws to 20 to 25 in-lb (2 to 3 Nm) torque.
2. If the Throttle Valve Seat (5) was removed, drop the Seat into the air inlet chamber in the handle. Install a new Throttle Valve Seat by pushing it into position against the shoulder in the air inlet chamber with a 5/8" (16 mm) dowel.
3. Wipe the stem of the Trigger Assembly (2) with some light grease and insert the stem into the trigger bushing.
4. Installation of the Throttle Valve (3) is sometimes a bit tricky due to the smallness of the Valve and the depth of the bore in which it is located. The difficult part is in holding the Valve while inserting the long end of the valve stem through the hole in the trigger stem. Although the Valve can be held with a push-button mechanical pencil or a wooden dowel, one of the easiest ways of holding it is by using a common wooden pencil with a rubber eraser. Insert the short end of the valve stem into the rubber eraser, as far as possible, and then back it out until the Valve is just nicely supported. Insert the Valve into the bore of the handle so that the long end of the stem enters the hold in the trigger stem. Pull outward on the Trigger to hold the Valve while removing the pencil.
5. Install the Throttle Valve Spring (6), small end first.
6. Position the Exhaust Deflector (7) in the recess at the bottom of the handle and install the Inlet Bushing (8). Tighten the Bushing to 40 to 45 ft-lb (54 to 61 Nm) torque.

Assembly of the Reverse Valve

1. After applying O-ring lubricant to the Reverse Valve Seals (14), install them in the undercuts in the reverse valve bushing. Make certain they are properly seated.
2. Dampen the Reverse Valve (13) with IRAX No. 50 Oil. With the tool in an upright position, and while facing the back end of the tool, insert the Reverse Valve from left to right into the reverse valve bushing.

MAINTENANCE SECTION

- Place the Reverse Valve Knob (15) on the end of the Valve and, after applying Loctite® No. 601 to the Reverse Valve Knob Screw (16), fasten the Knob to the Valve with the Screw. Tighten the Knob Screw to 5 to 6 ft-lb (6.75 to 8.15 Nm) torque.

Assembly of the Motor

- Using a sleeve that will contact only the outer ring of the bearing, press the Front Rotor Bearing (27) into the Front End Plate (25) and the Rear Rotor Bearing (18) into the Rear End Plate (19).
- Slip the Front End Plate and Bearing over the splined hub of the Rotor (21).
- Grasp the splined end of the Rotor in leather-covered or copper-covered vise jaws with the Rotor in a vertical position.
- Dampen each Vane (22) with IRAX No. 50 Oil and insert a Vane into each vane slot in the Rotor.
- Set the Cylinder (23) over the Rotor and onto the Front End Plate.
- Slide the Rear End Plate and Bearing onto the Rotor hub and against the Cylinder.
- Using snap ring pliers, install the Rear Rotor Bearing Retainer (17) in the groove on the rotor hub.
- Align the dowel hole in both End Plates with the one through the Cylinder, and insert a guide rod 3/16" diameter x 8" long (4.7 mm diameter x 203 mm long) through the holes. Allow the rod to protrude about 3-1/2" (89 mm) from the Rear End Plate.
- While holding the assembled motor intact, remove it from the vise.
- Insert the protruding end of the guide into the cast slot at the bottom of the Motor Housing bore and slide the assembled motor along the rod until it is completely seated in the housing.
- Remove the guide rod and install the Cylinder Dowel (24).
- Install the End Plate Dowel (26).
- Grasp the handle of the Motor Housing in leather-covered or copper-covered vise jaws with the open end of the Motor Housing upward.
- Place a Motor Clamp Washer (28), concave side first, down over the hub of the Front End Plate so that the outer rim of the Washer contacts the Front End Plate. Place the second Motor Clamp Washer, convex side

first, down over the hub of the Front End Plate so that the inner rims of both Washers are in contact but the outer rims are separated.

- Place the Motor Retainer (29), small bore first, down over the hub of the Front End Plate and against the outer rim of the second Motor Clamp Washer.
- Place the Rear Hammer Frame Washer (35), hub side first, over the hub of the Rotor and against the Front Rotor Bearing.

Assembly of the Impact Mechanism

- Coat the Hammer (38) with a light film of IRAX No. 100 Grease.
- Slide the Hammer into the Hammer Frame (36) exactly as it was when you marked it prior to disassembly.

NOTICE

In order to utilize both impacting surfaces on the Hammer and thus equalize the wear on each hammer jaw, the Hammer can be flipped over so that the arrow is pointing downward.

- Replace the Hammer Pins (37).
- Examine the base of the Anvil (39) and note its contour. While looking down through the Hammer Frame, swing the Hammer to its full extreme one way or another until you can match the contour of the Anvil. Enter the Anvil into the Hammer Frame and through the Hammer.

Assembly of the Tool

- Set the assembled impact mechanism down over the splined hub of the Rotor.
- Position the Hammer Case Gasket (30) on the Housing.
- Work approximately 12 to 15 cc of IRAX No. 100 Grease into the impact mechanism.
- Smear a thin film of IRAX No. 100 Grease on the inside surface of the Hammer Case Bushing (32), and place the Hammer Case (31) down over the Anvil and against the Motor Retainer.
- Install the Hammer Case Cap Screws (33) and tighten them to 20 to 25 ft-lb (27 to 34 Nm) torque.
- Remove the Impact Wrench from the vise and inject 2 to 4 cc of IRAX No. 100 Grease into the Grease Fitting (12).

MAINTENANCE SECTION**TROUBLESHOOTING GUIDE**

| Trouble | Probable Cause | Solution |
|----------------------|--|--|
| Low power | Dirty Inlet Bushing or Air Strainer Screen and/or Exhaust Silencer | Using a suitable cleaning solution, in a well ventilated area, clean Air Strainer Screen, Inlet Bushing and Exhaust Silencer. |
| | Worn or broken Vanes | Replace complete set of Vanes. |
| | Worn or broken Cylinder and/or scored End Plates | Examine Cylinder and replace it if it is worn or broken or if bore is scored or wavy. Replace End Plates if they are scored. |
| | Dirty motor parts | Disassemble tool and clean all parts with a suitable cleaning solution, in a well-ventilated area. Reassemble tool as instructed in this manual. |
| | Improper positioning of Reverse Valve | Make certain that Reverse Valve is fully engaged to the left or right. |
| Motor will not run | Incorrect assembly of motor | Disassemble motor and replace worn or broken parts and reassemble as instructed. |
| | Insufficient lubricant in the impact mechanism | Remove Hammer Case Assembly and lubricate impact mechanism. |
| Tool will not impact | Broken or worn impact mechanism parts | Remove Hammer Case and examine impact mechanism parts. Replace any worn or broken parts. |
| | Impact mechanism not assembled correctly | Refer to Assembly of the Impact Mechanism . |

NOTICE**SAVE THESE INSTRUCTIONS. DO NOT DESTROY.**

NOTES

NOTES

ARO

Part of worldwide Ingersoll-Rand

PN49999-525