

OWNER'S MANUAL

**MODEL NO.
625.343420**

Caution:
Read and Follow
All Safety Rules,
Installation and
Operating
Instructions
Before First Use
of This Product.

If you have questions
when installing and us-
ing your water filter
housing call this toll-
free number...

1 - 800 - 426 - 9345

SAVE THIS MANUAL



DELUXE MULTI-PURPOSE WATER FILTER HOUSING

- ◆ Safety Guides
- ◆ Installation
- ◆ Operation
- ◆ Cartridge Replacement
- ◆ Repair Parts

SAFETY GUIDES / SPECIFICATIONS

√ Please read this entire manual before installing and using your deluxe multi-purpose water filter housing. Be sure to follow all guides and rules carefully. Failure to follow them could cause personal injury or property damage.

√ Check with your local public works department for plumbing codes. You must follow their guides as you install the water filter housing.

√ Use the filter on a potable, safe-to-drink, home COLD water supply only. The filter

cartridge will not purify water, or make it safe to drink. DO NOT use on HOT water (100°F, max.), microbiologically unsafe water, or on water of unknown quality.

√ Protect the water filter housing and piping from freezing. Water freezing in the housing will break it.

√ Your deluxe multi-purpose water filter housing will withstand up to 125 psi water pressure. If your house water supply pressure is higher than 100 psi, install a pressure reducing valve before the water filter.

Maximum Supply Water Pressure	125 psi
Min. – Max. Supply Water Temperature	40 – 100 °F
Inlet – Outlet Thread Size	3/4" NPT

WARRANTY

FULL ONE YEAR WARRANTY ON DELUXE MULTI-PURPOSE WATER FILTER HOUSING (disposable filter cartridge not included)

For one year from the date of purchase, Sears will replace this Deluxe Multi-Purpose Water Filter Housing, (except filter cartridge, which is purchased separately), free of charge, if defective in material or workmanship.

WARRANTY IS AVAILABLE BY SIMPLY RETURNING THE WATER FILTER HOUSING TO THE NEAREST SEARS STORE THROUGHOUT THE UNITED STATES.

This warranty gives you specific legal rights, and you may have other rights which vary from state to state.

Sears, Roebuck and Co., DEPT. 817 WA, Hoffman Estates, IL 60179

TABLE OF CONTENTS

Water Treatment Filter Cartridges	3 – 4
Planning Installation	4 – 5
Typical Installation Drawings / Tools and Materials Needed	5
Water Filter Housing Installation	6 – 8
Filtering All House Water	6 – 7
Using Compression Fittings	6
Using Soldered Copper	7
Using Threaded Fittings	7
Filtering Water To One Faucet (Installing Under Sink)	8
Installing Filter Cartridge	8
Filter Cartridge Life / Replacement	9–10
Repair Parts	11

WATER TREATMENT FILTER CARTRIDGES

Filter cartridges are available (not included with water filter housing) from Sears to remove (1) sediments, (2) tastes and odors, (3) tastes, odors and chemical contaminants, and (4) tastes, odors and lead. To treat slightly acid and corrosive water supplies, Sears has a cartridge (5) to add food grade phosphates.

Following is a list of filter cartridges available at the time of this printing. Shop your local Sears store for the current selection.

(1) Sediment Filter Cartridge, Sears Item No. 42-34360 (25 micron), or Item No. 42-34362 (5 micron): Sediment cartridges remove sand, silt, clay, dirt, and other sediments from water. The 25 micron cartridge filters larger sediments from water, and allows higher flows at less pressure drop. The 5 micron cartridge filters finer sediments from water, usually to a single faucet.

Many bad tastes and/or odors are removed from water by an activated carbon cartridge. It is most often used to remove chlorine taste and smell, usually to a single faucet such as the kitchen cold.

Note: Small amounts of hydrogen sulfide (noticeable as “rotten egg” odor) may be reduced by taste and odor filters for a short time, quickly exhausting the carbon media. Consult your Sears store for proper continuous treatment.

Sears has several **taste and odor filter cartridges** available. These are:

(2) Sears Item No. 42-34370: for 95% chlorine reduction,

and **Sears Item No. 42-34372:** for 99% chlorine reduction

(3) Sears Item No. 42-34365: for 99% chlorine reduction, *plus* chemical contaminants

(4) Sears Item No. 42-34377: for 99% chlorine reduction, *plus* 95% lead reduction

To filter sediments or tastes and odors from *all* house water, locate the water filter housing on the main water supply pipe. You can also filter water to one faucet. For example, install the filter under the kitchen sink to filter the cold drinking water. Refer to the following drawings. *Typically, taste and odor filters are installed to filter water to 1 faucet only.* Refer to the following drawings.

FILTERING ALL HOUSE WATER

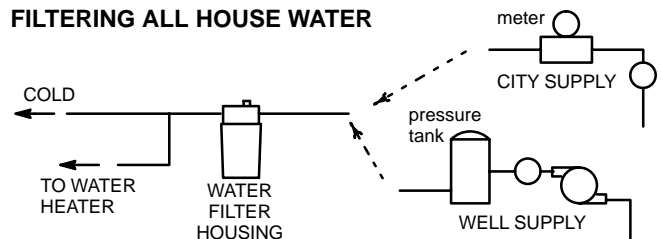

FILTERING WATER TO ONE FAUCET

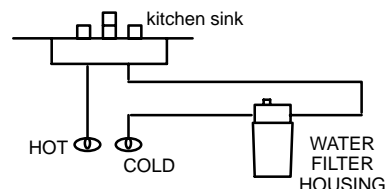

continued

WATER TREATMENT FILTER CARTRIDGES (cont.)

(5) Phosphate Cartridge: This cartridge adds pure food grade phosphate into the water supply. Phosphates coat the insides of pipes, plumbing fixtures, the water heater, etc. The coating keeps slightly acid (6.8 – 6.9 pH) and corrosive water away from the surfaces to help prevent rusting, staining and scaling.

Note: Acid water, below 6.8 pH, requires other water conditioning. Have a sample of your water analyzed by a qualified water testing laboratory and get their recommendation for treatment. You can get a free water analysis at your nearest Sears store.

When adding phosphates to your water system, locate the water filter housing to treat:

- THE ENTIRE HOUSE SUPPLY [1], OR
- BOTH HOT AND COLD *SOFT* WATER [2], OR
- HOT WATER ONLY [3]

Note: If no other water conditioning units are installed, always treat the entire house supply [1].

[1] ADDING PHOSPHATE TO ALL HOUSE WATER

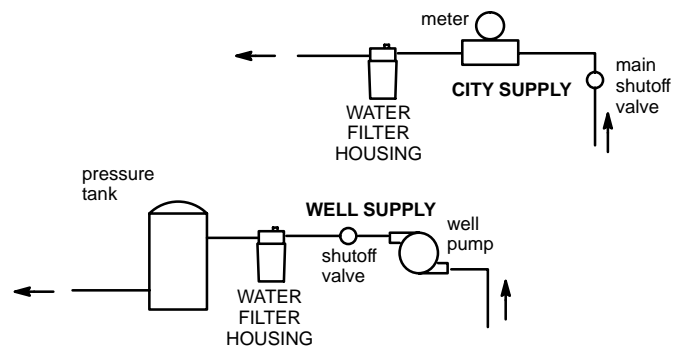

[2] ADDING PHOSPHATE, SOFT HOT/COLD HOUSE WATER

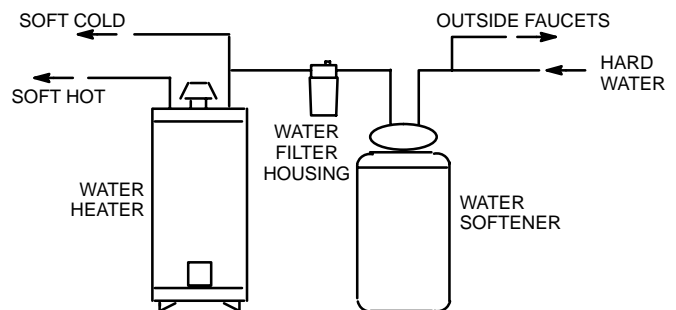

[3] ADDING PHOSPHATE, HOT HOUSE WATER ONLY

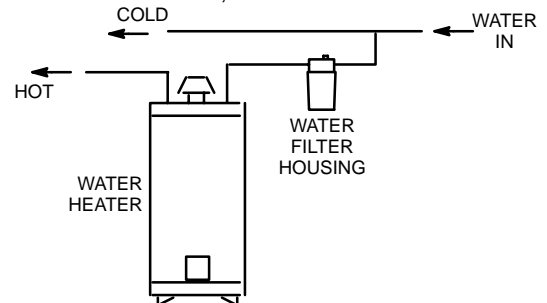

PLANNING YOUR INSTALLATION

When planning your installation, first read the preceding filter cartridge information and decide where to locate the water filter housing. Then, use the drawings on page 5 to guide you. There are many variables to consider as you plan. Some of these are:

- ✔ The water filter housing inlet and outlet internal threads are 3/4" NPT.
- ✔ existing plumbing type (copper, threaded, etc.) and nominal size (1/2", 3/4" etc.)
- ✔ tools you have, and your plumbing skills
- ✔ cost of materials needed
- ✔ space available for installing the filter housing

Sears has optional kits available to make installing the water filter housing easier (see page 5). These are:

★ Installation Kit, Sears Item No. 42-34346 – Includes fittings to fit nominal 1/2" (5/8" O.D.) or 3/4" (7/8" O.D.) copper.

★ Installation Kit, Sears Item No. 42-34347 – Includes 3/4" and 3/8" fittings, and 3/8" tubing to connect to a single faucet.

★ Mounting Bracket, Sears Item No. 42-34348 – primarily, for undersink installation

Make a simple sketch of your proposed installation, and a list of plumbing materials you will need. Obtain everything you need before starting the installation. Be sure you have the tools required.

TYPICAL INSTALLATIONS / TOOLS AND MATERIALS NEEDED

FIG. 1 INSTALLATION ON COPPER PLUMBING USING COMPRESSION FITTINGS

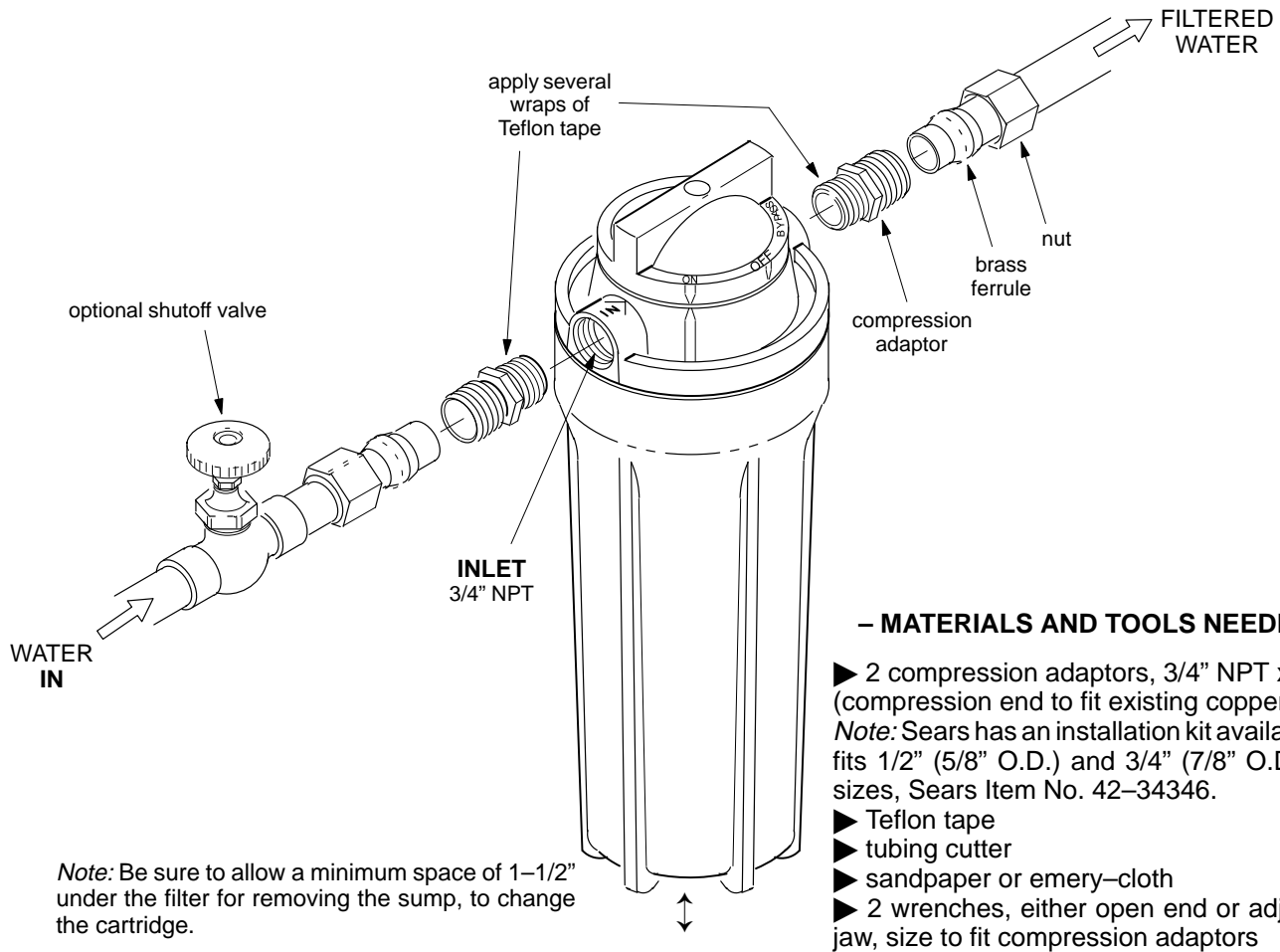

FIG. 2 SOLDERED COPPER INSTALLATION
(OBSERVE FIG. 1 NOTES)

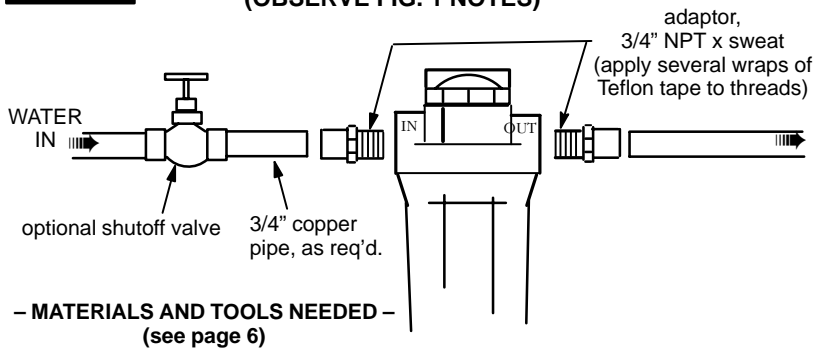

FIG. 3 THREADED INSTALLATION
(OBSERVE FIG. 1 NOTES)

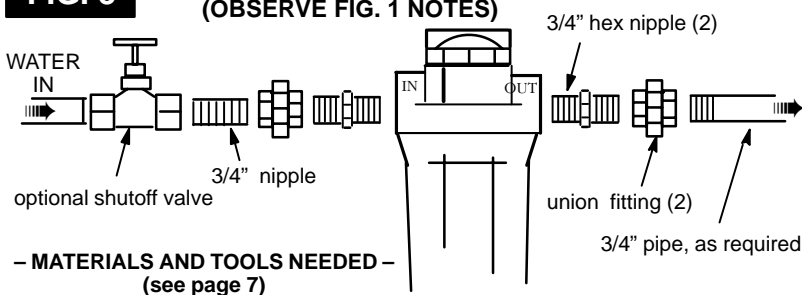
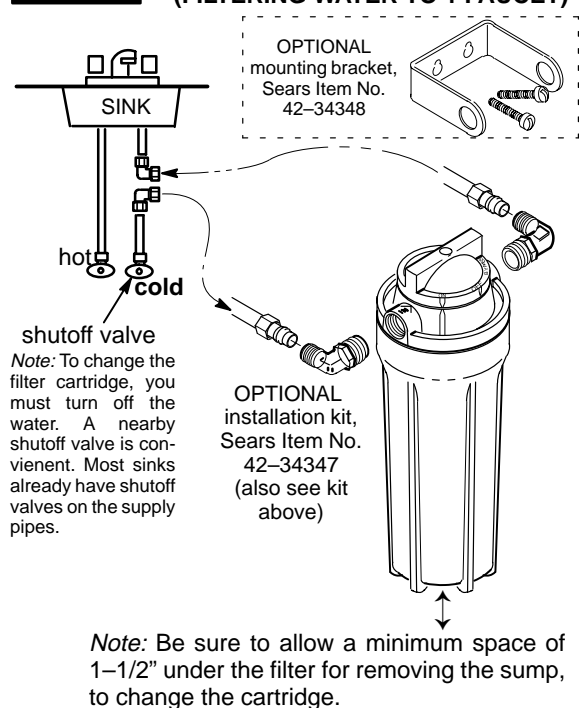

FIG. 4 UNDERSINK INSTALLATION
(FILTERING WATER TO 1 FAUCET)



INSTALLATION STEPS

WATER FILTER HOUSING ON HOUSE MAIN WATER PIPE, TO FILTER ALL HOUSEHOLD WATER

A. USING COMPRESSION FITTINGS, FIG. 1

1. Apply several wraps of Teflon tape to the threads of both compression fittings.
2. CAREFULLY, turn the compression fittings into the water filter head inlet and outlet and tighten. **Do not cross-thread** and damage the threads. **Do not over-tighten** and crack the head.
3. Remove the nut and brass ferrule from both compression fittings and set aside. Using a tape measure or ruler, measure the distance "D" as shown below. Mark this dimension below so you do not forget.

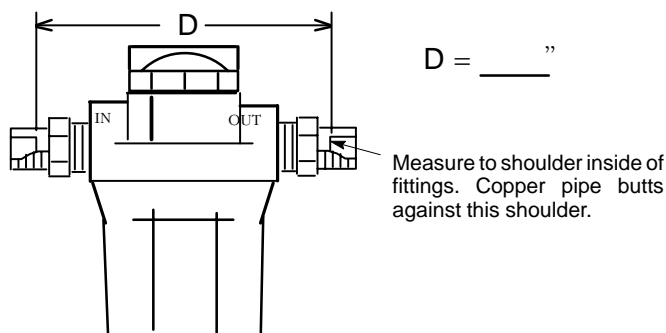

4. **CAUTION: Turn off the water supply** to the main pipe. Open a high and low faucet, in the water system, to drain the pipe.
5. On the main water pipe, where you will install the filter, mark the dimension D. You will remove this section of pipe. **Before you begin to cut, double-check your measurement.**
6. Use a tubing cutter to remove the section of pipe. Remove all burrs and rough edges with the sandpaper or emery-cloth.
7. Place a nut and brass ferrule (from compression fittings) onto both pipe ends.

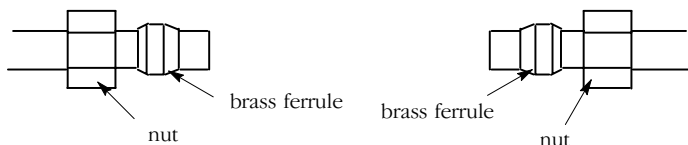

8. With the **inlet side of the water filter facing incoming water**, spread the pipes apart and fit both pipe ends into the compression fittings. Move a ferrule and nut up to the fitting. Then, turn on and tighten the nut. *Hold the fitting with 1 wrench while tightening the nut with the other.* Repeat on the other side.

Note: If water flow is from right to left (➡), be sure to turn water filter so inlet is to the right.

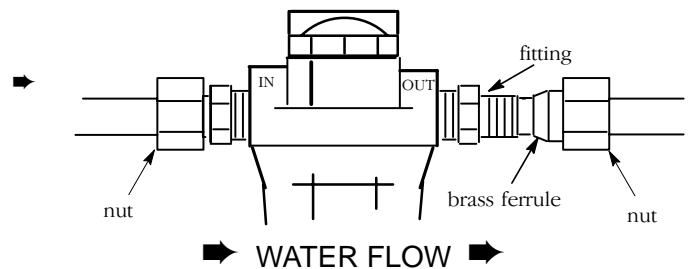

9. **Before turning on the water supply**, remove the sump from the filter head and install the filter cartridge (see page 8).

IMPORTANT: The house cold water pipe is often used to ground electrical outlets in the home. **Grounding protects you from electrical shock.** The water filter housing may have broken this ground. To restore, buy and install a #4 copper wire across the filter, tightly clamped at both ends as shown here.

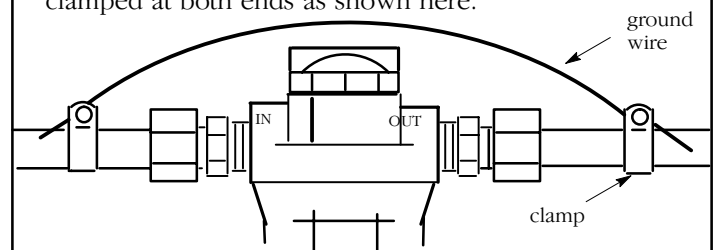

B. SOLDERED COPPER FITTINGS, FIG. 2

MATERIALS AND TOOLS NEEDED: You will need 2 sweat adaptors, 3/4" NPT x sweat (sweat end to fit your main water pipe), lead-free solder and flux, soldering torch, Teflon tape, sandpaper or emery-cloth, open end (to fit sweat adaptor) or adjustable jaw wrench.

CAUTION: Heat created when soldering can damage the water filter housing. Be sure to use the following procedures to protect the water filter.

1. **CAUTION: Turn off the water supply** to the main pipe. Open a high and low faucet, in the water system, to drain the pipe.

INSTALLATION STEPS (cont.)

WATER FILTER HOUSING ON HOUSE MAIN WATER PIPE, TO FILTER ALL HOUSEHOLD WATER

2. On the main water pipe, where you will install the filter, use a tubing cutter to remove a section of pipe about 12" long. Use sandpaper or emery-cloth to thoroughly clean, and remove all burrs and rough edges, from both pipe ends.

Note: When soldering, **use lead-free solder and flux only**. Be sure pipe and fittings are properly cleaned. Observe caution note in opposite column.

3. Solder a sweat adaptor onto 1 of the pipe ends.

4. Place, but do not solder, a straight connector onto the other pipe end.

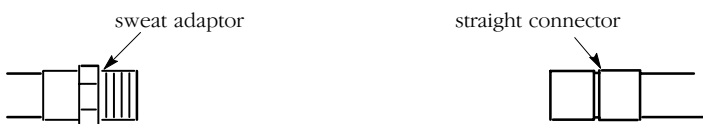

5. Remove the sump from the filter head and set the sump aside.

6. *After it cools*, apply several wraps of Teflon tape to the threads on the sweat adaptor fitting.

7. **Carefully**, turn the filter head INLET (if water flow is from the left) onto the sweat adaptor fitting. If water flow is from the right, turn the outlet side of the head onto the fitting. **Do not cross-thread, or over-tighten** and crack the filter head.

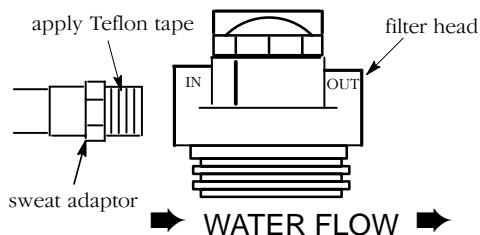

8. Turn a sweat adaptor fitting into the other side of the filter head and **hand tighten only**. Using a tape measure or ruler, measure the distance "D" as shown below. Mark this same dimension on a length of copper pipe. Cut the length of pipe.

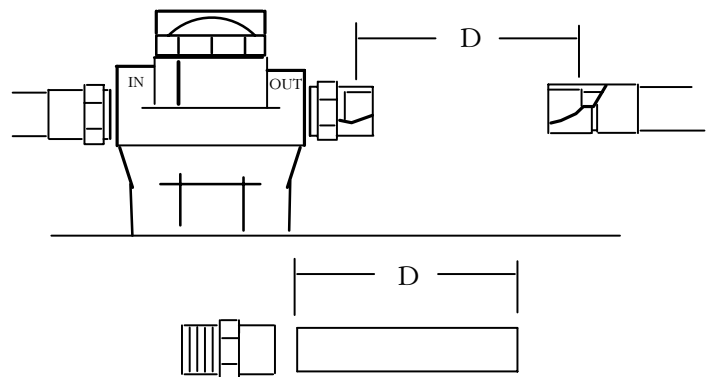

9. Remove the sweat adaptor fitting from the filter head and solder to the cut length of pipe.

10. *After it cools*, apply several wraps of Teflon tape to the threads on the sweat adaptor fitting. Apply flux and place the pipe end of the soldered assembly into the straight connector. Then, turn the adaptor end into the filter head and tighten.

11. Solder both sides of the straight connector.

12. **Before** replacing the sump and **turning on the water supply**, install the filter cartridge (see page 8).

Note: **Read the grounding information on page 6**, and comply with the instructions if required to maintain continuity.

C. THREADED PIPE AND FITTINGS, FIG. 3

MATERIALS AND TOOLS NEEDED: For threaded pipe installation, you will need a pipe threading tool, pipe wrenches, pipe joint compound, union fittings and pipe nipples. Connect the filter housing as typically shown in FIG. 3, page 5. Observe the following:

- Use pipe joint compound on all external threads.

■ Do not turn pipe or fittings to tightly into the filter head or you may break it.

■ It is important to have some linear movement in the house main water pipe. This will allow you to tighten union fittings, without damaging the filter head, if pipe lengths are not exact.

Note: **Read the grounding information on page 6**, and comply with the instructions if required to maintain continuity.

INSTALLATION STEPS (cont.)

WATER FILTER HOUSING UNDERSINK, TO FILTER WATER TO 1 FAUCET

REFER TO FIG. 4, PAGE 5. If optional kits are used, follow instructions included with them.

1. Close the **cold** water side shutoff valve. (Usually, there already is a shutoff under the sink. If not, close the main water shutoff valve near the water meter or pressure tank.)

2. Cut and remove a section of the cold water pipe.

3. If plumbing with flexible tubing, hang or support the filter housing in some manner (the optional mounting bracket is preferred). If using rigid pipe, be sure to allow a minimum of 1-1/2" clearance under the filter for sump removal when changing the filter cartridge.

4. Use the plumbing procedures on page 6 if using compression fittings. Follow procedures on pages 6 and 7 for sweat copper and threaded pipe installation. **Be sure water flow is into the filter inlet side**, and from the outlet side, to the faucet.

Note: A grounding jumper wire is not required.

5. Before turning on the water supply, remove the sump from the filter head and install the filter cartridge (see below).

FILTER CARTRIDGE INSTALLATION

TURN TO PAGE 9 AND FOLLOW ALL STEPS UNDER "FILTER CARTRIDGE REPLACEMENT".

FILTER CARTRIDGE / USEFUL LIFE / REPLACEMENT

FILTER CARTRIDGE LIFE

Several variables determine how long a cartridge will last. These include:

1. where the water filter is installed (filtering all house water, or just to 1 faucet)
2. how much water you use
3. how much sediment, taste and/or odor, or other unwanted substance, is in the water

Use the following information as a guide. However, no matter which type of cartridge you are using, you will know **it is time to replace it when you first notice the return of the unwanted substance in your water.**

Sediment Cartridges: Cartridge life, when filtering water to 1 faucet, is about 6 months maximum. Cartridge life is less when filtering all house water. This time varies depending on the type of sediment cartridge.

Filtering sediments, you will know it's time to replace the cartridge when water pressure drops to the single faucet, or to the entire house supply.

Taste and Odor Cartridges: Filtering water to a single faucet, the filter cartridge may last for 6 months or more. Cartridge life is less when filtering all house water. If the cartridge is also for lead or chemical contaminant removal, it is more important to replace it frequently.

Phosphate Cartridge: The cartridge is filled with pure food grade phosphate crystals. The crystals slowly dissolve, and the phosphates coat the insides of the plumbing. This coating keeps the slightly acid or corrosive water away from the inside surfaces to help stop rusting, staining and scale.

In addition to the previously mentioned variables, water temperature, hardness and pH are all factors in how fast the crystals dissolve. After **4 or 5 months**, check the cartridge to see how many crystals remain. Replace the cartridge, or refill with crystals if needed (see page 11). Otherwise, check the cartridge again after several more months. After checking a few times, you will know about how fast the crystals are dissolved, and the frequency replacement of the cartridge or crystals is needed.

FILTER CARTRIDGE REPLACEMENT

CAUTION: Never remove the sump with water pressure in the filter.

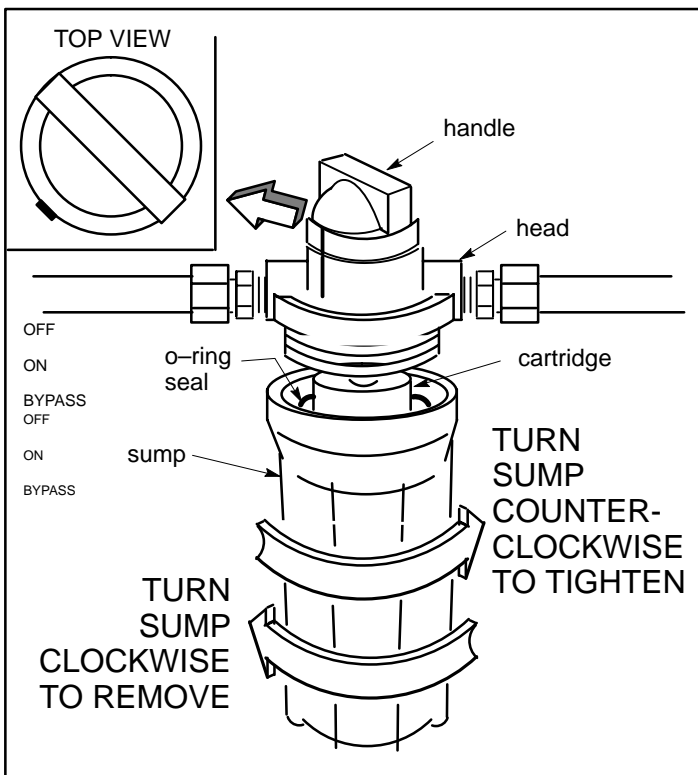

1. Turn the filter handle to the OFF or BYPASS position, to relieve pressure in the filter. It is normal for some water to leak out.

2. Turn the sump off of the filter head, to the left or clockwise. Be careful, the sump is full of water. Do not lose the large o-ring seal.

Note: A **special wrench** is available from Sears for removing the sump. See the parts list on page 11.

3. Be sure the inside of the sump is clean. Cleaners are available from Sears (see the parts list on page 11), or use hot, soapy water.

4. Remove the wrapper from the new filter cartridge and insert the filter cartridge in the sump. Some cartridges fit either way, while others fit only one way. Observe markings on the cartridge, or on the wrapper.

5. Lightly lubricate the o-ring seal, in the sump, with silicone grease or Vaseline. Be sure it is fully seated in the groove.

6. Hold the sump up to the filter head, aligning the center hole in the cartridge with the protrusion on the bottom of the head.

continued

FILTER CARTRIDGE / USEFUL LIFE / REPLACEMENT (cont.)

Note: If the sump will not tighten, up to the head, you may have the cartridge in upside down. Take the cartridge out and check for correct orientation.

7. Being careful not to cross-thread, turn the sump onto the filter head and tighten securely.

8. If the filter is installed for all house water filtering, partially open a house faucet on the outlet side of the filter housing. Open the sink faucet if the filter is an undersink installation. **Then, turn the filter handle to ON**, allowing the filter housing to fill with water.

9. Close the house faucet. Then, check for leaks between the sump and the head.

Note: If leaking, turn off the water supply and depressurize the filter. Then, disassemble the filter and check the o-ring for cuts, flat spots, etc., and sealing surfaces for foreign material. Relubricate the o-ring with silicone grease or Vaseline and carefully press into the groove in the sump.

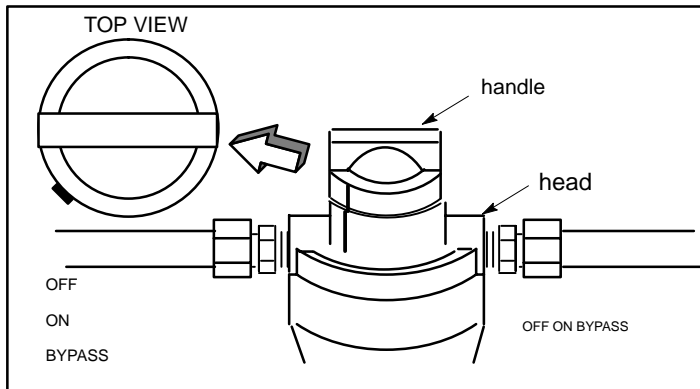

REPAIR PARTS

Kenmore Deluxe Multi-Purpose Water Filter Housing, Model No. 625.343420

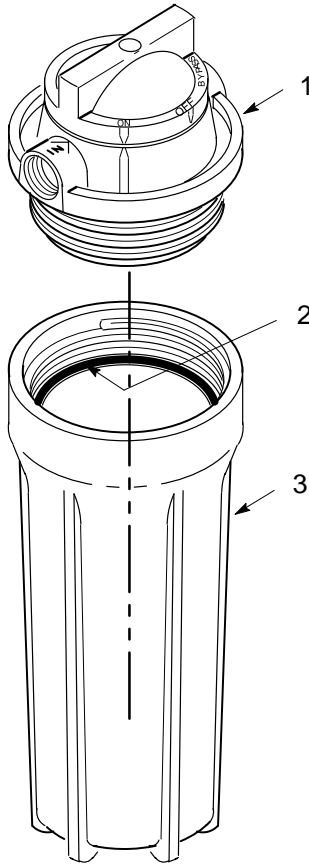

KEY NO.	PART NUMBER	DESCRIPTION
1	7164944	Head Assembly
2	42-34345	O-ring, 3-7/8" I.D. x 4-1/8" O.D.
3	7156543	Sump
◆	7182269	Owners Manual
♣	42-34360	Sediment Cartridge, 25 micron
♣	42-34362	Sediment Cartridge, 5 micron
♣	42-34370	Taste & Odor Cartridge, 95% chlorine reduction
♣	42-34372	Taste & Odor Cartridge, 99% chlorine reduction
♣	42-34365	Taste & Odor / Chemical Contaminate Cartridge
♣	42-34377	Taste & Odor / Lead Cartridge
♣	42-3453	Phosphate Crystal Cartridge
♣	42-3443	Repl. Phosphate Crystals
♣	42-34330	Sump Cleaning Kit
♣	42-34331	Sump Cleaning Solution
♣	42-34334	Sump Removal Wrench

◆ not illustrated

♣ available options from Sears at the time of this printing, not illustrated, and not included with Water Filter Housing

OWNERS MANUAL

**MODEL NO.
625.343420**

The model number of your deluxe water filter housing is found on the rating decal, on the filter sump.

When requesting service or ordering parts, always provide the following information:

- ◆ Product Type
- ◆ Model Number
- ◆ Part Number
- ◆ Part Description



DELUXE MULTI-PURPOSE WATER FILTER HOUSING

For the repair or replacement parts you need

Call 7 am – 7 pm, 7 days a week

1 – 800 – 366 – PART

(1 – 800 – 366 – 7278)

For in-home major brand repair service

Call 24 hours a day, 7 days a week

1 – 800 – 4 – REPAIR

(1 – 800 – 473 – 7247)

**For the location of a
Sears Repair Service Center in your area**

Call 24 hours a day, 7 days a week

1 – 800 – 488 – 1222

**For information on purchasing a Sears
Maintenance Agreement, or to inquire
about an existing Agreement**

Call 9 am – 5 pm, Monday – Saturday

1 – 800 – 827 – 6655