

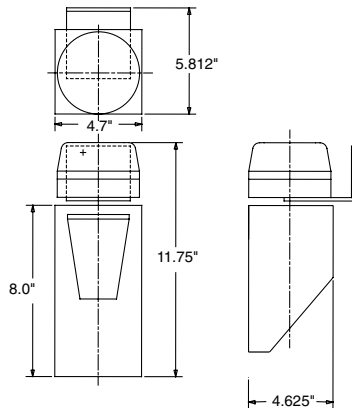

SIREN LOUDSPEAKERS FOR CONCEALED INSTALLATION

HPH-370GB



DIMENSIONS

FEATURES

- 100-Watt Power Handling with High Intelligibility and Sound Penetration
- Rugged, All-Metal, Weather-resistant Construction
- Specifically Designed for Concealed Installation in Electronic Siren and Signalling Applications

APPLICATIONS

Utilize the HPH-370GB re-entrant, directional loudspeaker for concealed installation in electronic signal, alarm, public address, and other high-intelligibility, mobile emergency communication and signaling applications. Because of its compact size, the unit can be mounted under the hood, in front of or behind the radiator, or near a fender-well of most fully equipped vehicles.

The HPH-370B (conservatively rated at 100 watts RMS in electronic siren use) is recommended for high-powered systems in public safety, civil authority, military, or emergency medical applications.

GENERAL DESCRIPTION

Atlas Sound HPH-370GB siren loudspeaker is a double re-entrant type directional model with a 100-watt power rating. The assembly is compact in size and styled specifically for concealed installation in limited space applications. Units can be mounted to any ambulance, fire, law enforcement, utility, or other public service vehicle. A unique, heavy-duty, steel mounting bracket permits full-axis orientation of the loudspeaker for preferred sound-projection directivity. The projector assembly is manufactured of welded, heavy-gauge steel and finished in black baked epoxy for optimum durability and corrosion protection.

HPH-370B contains the patented Atlas Sound SD370A compression driver (U.S. Patent #7,760,501) complete with a non-fatiguing, self-aligning sound chamber assembly. Units are shipped complete with all components and installation data for field assembly. (Replacement head assembly, Model K-370A for replacement driver assembly, SD-370A, is available for field replacement). HPH-370B is suitable for use with matched amplifier and control equipment in systems requiring AMECA (Automotive Manufacturer Equipment Compliance Agency, Inc., formally the AAMVA) certification to General Services Administration specifications (KKK-A-1822C).

ENGINEER & PURCHASING SPECIFICATIONS

Siren loudspeaker shall be an Atlas Sound Model HPH-370GB. Assembly shall include a double re-entrant loudspeaker and 11-ohm compression driver. Power rating shall be 100 watts RMS at full range with nominal frequency response range of 450-4000 Hz. Sound level shall be 118dB when measured at full rated power at 3 meters (ref: .0002 dynes/cm²). Unit shall be furnished with a steel mounting bracket and have a field-replaceable driver-head assembly.

SPECIFICATIONS

MODEL	POWER RATING	IMPEDANCE	FREQUENCY RESPONSE	SOUND LEVEL (dB)	DISPERSION	DIMENSIONS W x H x D	FINISH	SHIPPING WEIGHT
HPH-370GB	100 Watts RMS	11 Ohms Nominal	Nominal 450-4000 Hz (±6dB)	118dB* 100dB**	105° Mounted Ver. 75° Mounted Hor.	4.75" x 11.621" x 4.625" (121 x 295 x 117 mm)	Black Epoxy	12 lbs (5.4 kg)

* Rated Power @ 1 meter ** Measured at 1 watt, 1 meter. (Ref.: .0002 dynes/cm²)

Specifications subject to change without notice



1601 JACK MCKAY BLVD. / ENNIS, TEXAS 75119 U.S.A.
TELEPHONE: (800) 876-3333 / FAX (800) 765-3435

AtlasSound.com

SEVEN

337

Frequency	Lp	Q	D
500	96.38	2.30	3.62
1000	95.83	2.61	4.17
2000	93.99	3.99	6.01
4000	91.45	7.16	8.55
8000	91.22	7.55	8.78

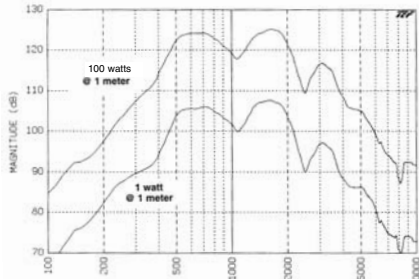

Frequency vs. Response

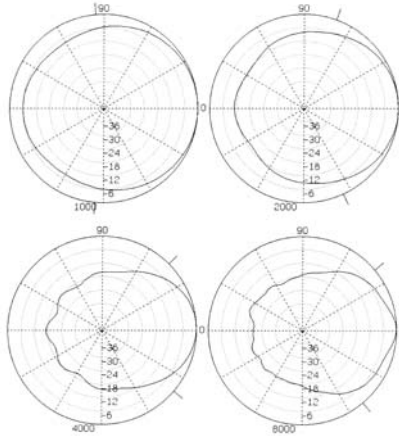

Polars with Unit Mounted Vertically

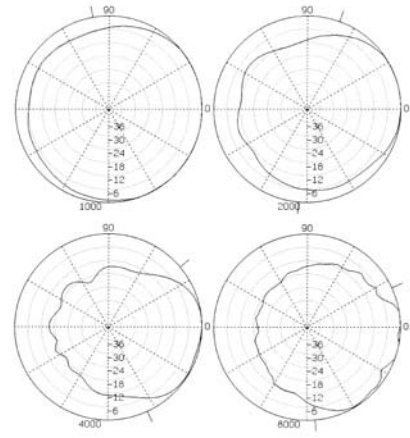

Polars with Unit Mounted Horizontally

Assembly Diagram

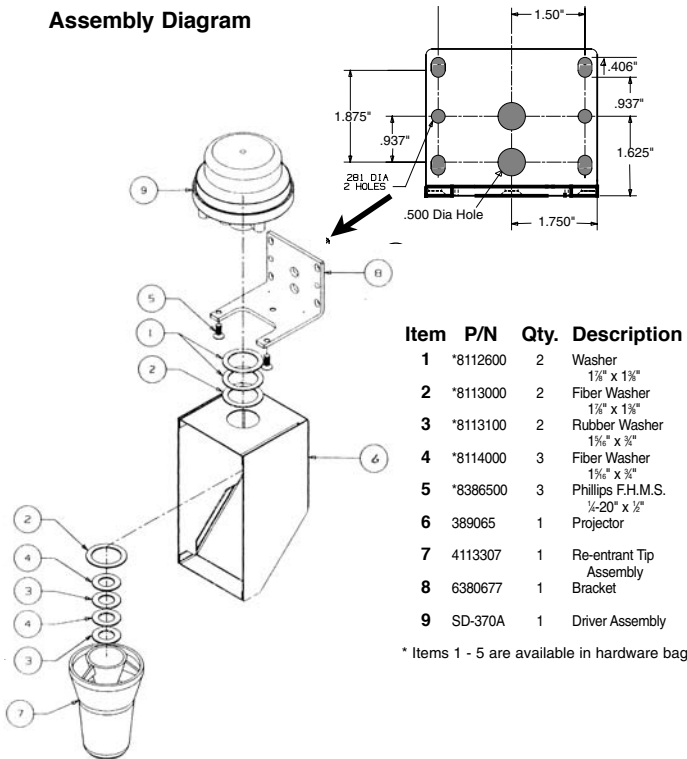

ASSEMBLY/INSTALLATION

Model ships complete with all components, compression driver, and hardware necessary for complete assembly as illustrated. Prior to assembly, crimp or solder the interconnecting cable from the amplifier output to the quick-connect terminals supplied. (Do not solder cable directly to the driver connection terminals.) Phasing must be observed in all installations of more than one loudspeaker. The black terminal is common.

Assemble all components and hardware in sequence as illustrated. Driver must be oriented with drain hole in downward position. Rotate loudspeaker on axis for desired forward sound projection; then securely hand tighten re-entrant tip assembly. After mounting, tighten all bracket screws securely.

DRIVER - TOP VIEW

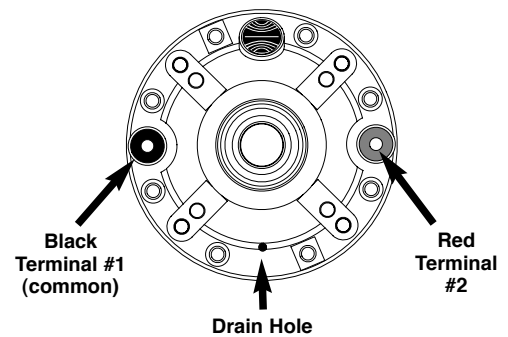

Specifications subject to change without notice



1601 JACK MCKAY BLVD. / ENNIS, TEXAS 75119 U.S.A.
TELEPHONE: (800) 876-3333 / FAX (800) 765-3435

AtlasSound.com