

Airborne Heavy Duty 802.11b/g Wireless Ethernet Bridge

ABDG-ET-HD101 series



Heavy duty enclosure for extreme conditions

Create a wireless connection between 802.11 wireless LAN device with an Ethernet port to transparently convey data between the device and a 10Base-T interface. The heavy duty ethernet bridge includes 802.11b/g technology that enables systems and opens up the world of remote device monitoring and management.

With a durable enclosure, it shields the device from external elements, including water, dust and other environmental threats. This powerful tool is an ideal solution for vehicle mounting, industrial shop floors or any other extreme environment surroundings.

802.11 wireless connectivity

The Airborne Heavy Duty Wireless Ethernet Bridge is an ethernet to 802.11 bridge capable of linking a host system to a wireless 802.11 network.

The highly integrated hardware enables plug-and-play capabilities, while significantly reducing complexities of wireless system deployment and network connectivity.

The device includes a physical interface to the wired network through a 12-pin connector integrated into the enclosure. The 802.11 RF interface is provided by an enclosure mounted RP-SMA connector.

The device is supplied in a Deutsch EEC-325X4B enclosure and is available in both sealed and *unsealed versions. Connection to the Ethernet power and control interfaces is through the 12-pin DTM13-12PA-R008 receptacle.

Applications

The Airborne bridge enable telematics systems to connect to corporate and public wireless LAN networks, commonly deployed at warehouses, ports and transit centers.

Ruggedized hardware is incorporated for harsh environmental conditions faced by trucks, buses, heavy equipment and automobiles. In addition, the Airborne Heavy Duty Bridge runs directly on vehicle battery power to enable easy integration by telematics solution providers.

* For sealed versions, please contact Airborne Sales Team

Model Selection Guide

Model No.	WiFi		Interface	Security			RoHS Compliant
	802.11b	802.11b/g	10 Base T	WEP (64 & 128 bit)	WPA	LEAP	
ABDG-ET-HD101		●	●	●	●		●
To evaluate all available features and receive evaluation tools, order below.							
ABEG-ET-HD101	Accessory Kit, 802.11b/g Ethernet bridge						

KEY FEATURES

- Extended operating temperature range (-40°C to +85°C) and environmental specifications
- Advanced security support includes WEP 64/128, WPA (TKIP), 802.1x (LEAP)
- SAE J1455 compatible power supply
- Low power modes
- Ruggedized Deutsch enclosure and connector
- 10Base-T interface
- 802.11b/g compliant radio
- Quick time to market & reduced development costs
- FCC Part 15 Class B Sub C Approval
- Reduces need for RF and communications expertise
- RP-SMA connector available for cable or direct antenna connection
- Device integration does not require OS specific drivers



Block Diagram

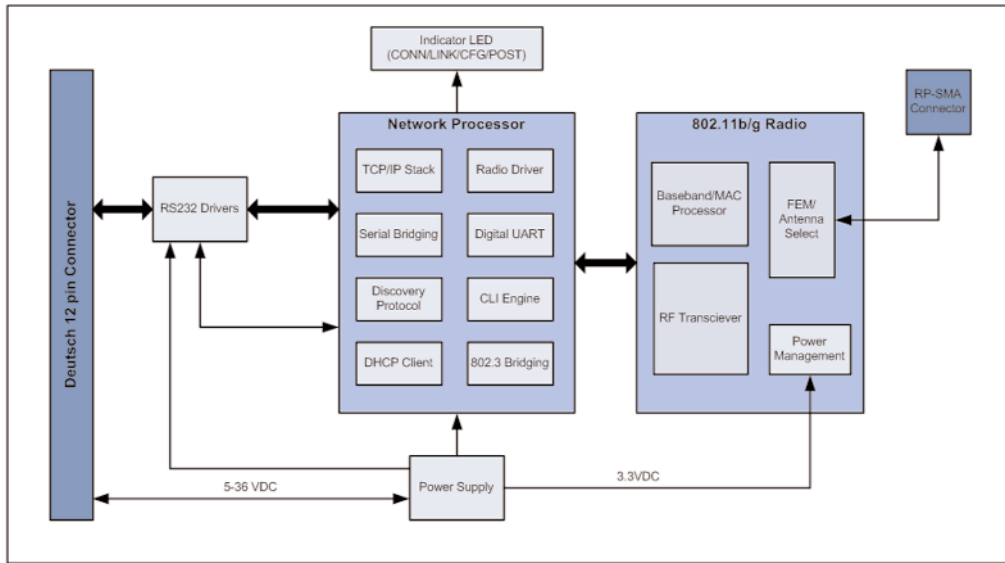

Mechanical Drawing

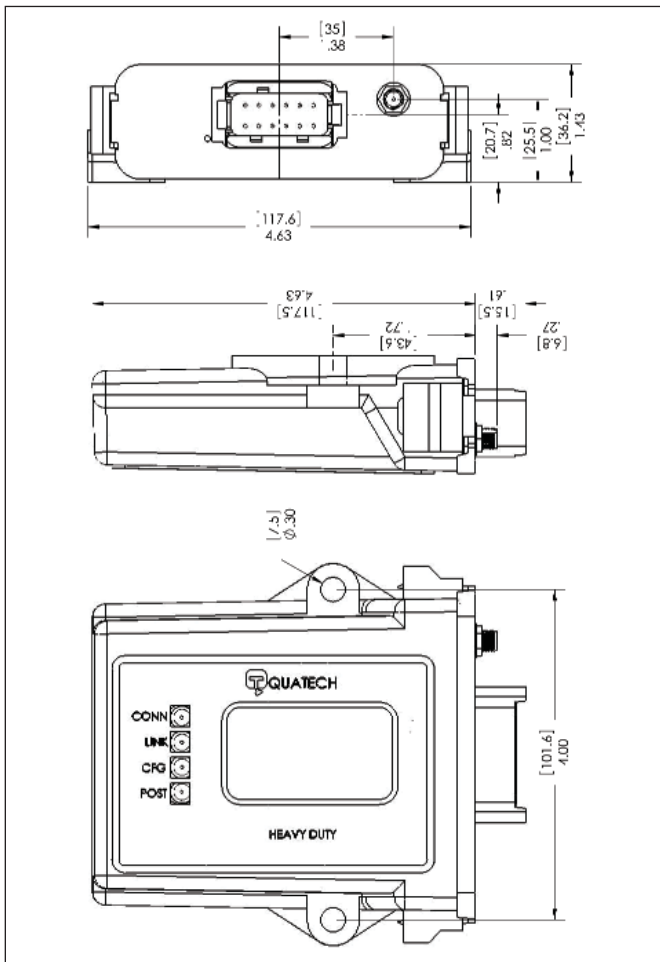

Specifications

Ethernet Interface	10Base-T, RJ-45 Male with pigtail, 10Mbps
Wireless Network Interface	IEEE 802.11b/g DSSS, WiFi Compliant
Frequency	2.4 - 2.4835 GHz (US, Europe, Canada, Japan) 2.471 - 2.497 GHz (Japan)
Channels	11 - US/Canada; 13 - Europe; 14 - Japan; 4 - France
Wireless Raw Data Rates	802.11b mode: 11, 5.5, 2, 1 Mbps 802.11g mode: 54, 48, 36, 24, 12, 9, 6 Mbps
RF Output Power	802.11b mode: +18dBm (typ) with 3dBi antenna 802.11g mode: +15dBm (typ) with 3dBi antenna
Security	WEP (64 & 128 bit), WPA (PSK & TKIP), WPA with LEAP
Antenna	Integrated RP-SMA connector
Status Indicators	POST, CFG, LINK, CONN
Power Input	5VDC to 36VDC, through Deutsch connector. Line level input control of power supply
Power Consumption	2W max
Device Management	Device discovery, Airborne Control Center application, web interface, plain text Command Line interface, firmware, upgrade, OEM configuration utility
Agency Approvals	US - FCC Part 15 Class B, C/UL, CE; Europe - CE; Canada - RS-210
OS Compatibility	Airborne - Win95/ME/NT/2000/XP/Vista and Linux; Airborne Control Center - Win2000/XP
Operating Temperature	-40° C to +85° C
Storage Temperature	-40° C to +125° C

QUATECH
A DPAC TECHNOLOGIES COMPANY

5675 Hudson Industrial Parkway Hudson, OH 44236

1.800.553.1170 www.quatech.com