

---

# INSTALLATION INSTRUCTIONS

---

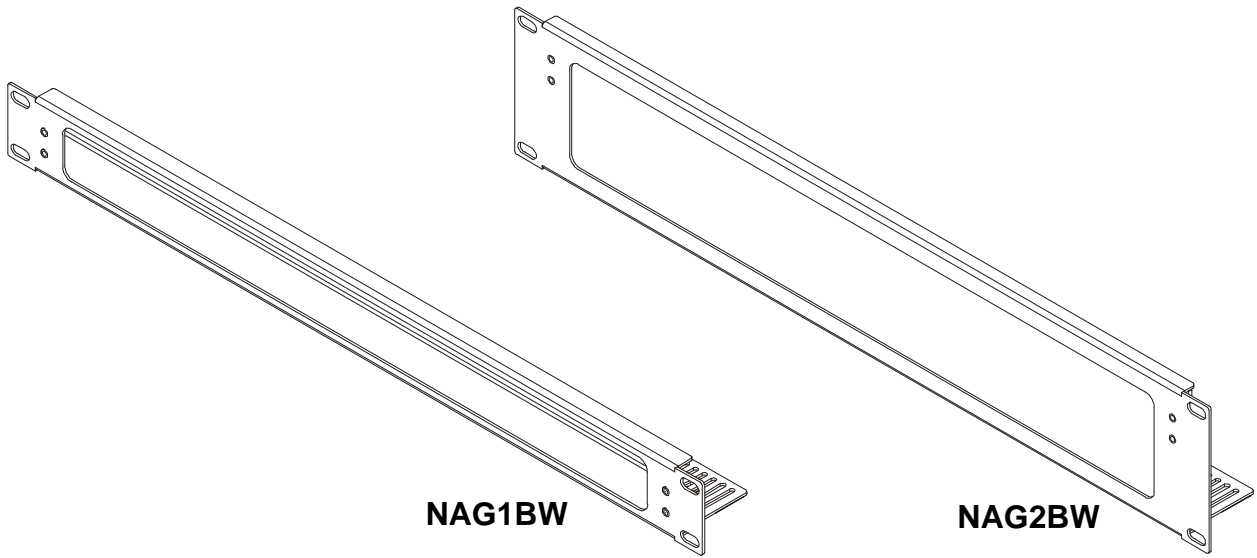

---

## 1U/2U Brush Grommet Accessories

---

**DISCLAIMER**

Milestone AV Technologies and its affiliated corporations and subsidiaries (collectively "Milestone"), intend to make this manual accurate and complete. However, Milestone makes no claim that the information contained herein covers all details, conditions or variations, nor does it provide for every possible contingency in connection with the installation or use of this product. The information contained in this document is subject to change without notice or obligation of any kind. Milestone makes no representation of warranty, expressed or implied, regarding the information contained herein. Milestone assumes no responsibility for accuracy, completeness or sufficiency of the information contained in this document.

Chief® is a registered trademark of Milestone AV Technologies. All rights reserved.

**! IMPORTANT WARNINGS AND CAUTIONS!**

**! WARNING:** A WARNING alerts you to the possibility of serious injury or death if you do not follow the instructions.

**! CAUTION:** A CAUTION alerts you to the possibility of damage or destruction of equipment if you do not follow the corresponding instructions.

**! WARNING:** Failure to read, thoroughly understand, and follow all instructions can result in serious personal injury, damage to equipment, or voiding of factory warranty! It is the installer's responsibility to make sure all components are properly assembled and installed using the instructions provided.

**DIMENSIONS - NAG1BW**

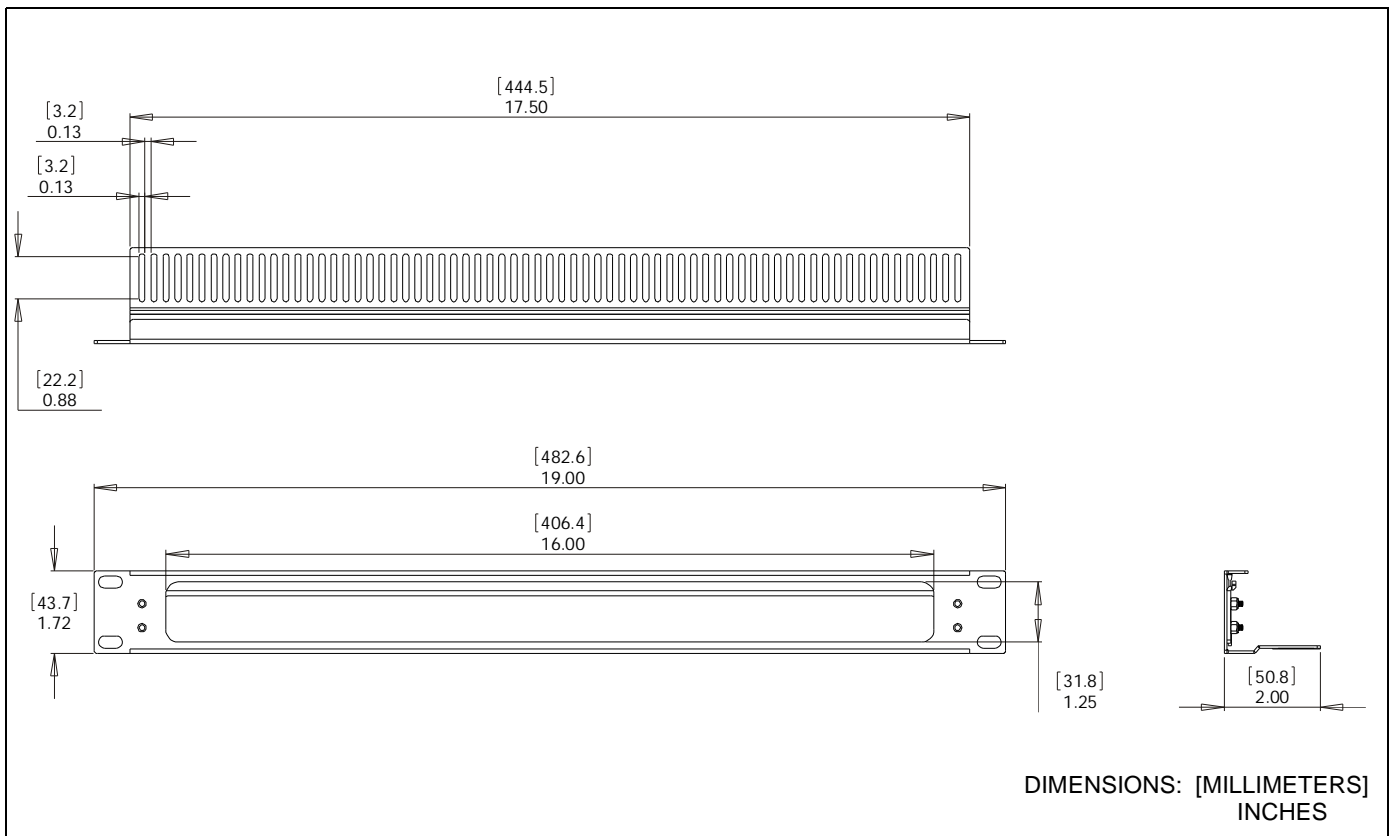

**DIMENSIONS - NAG2BW**

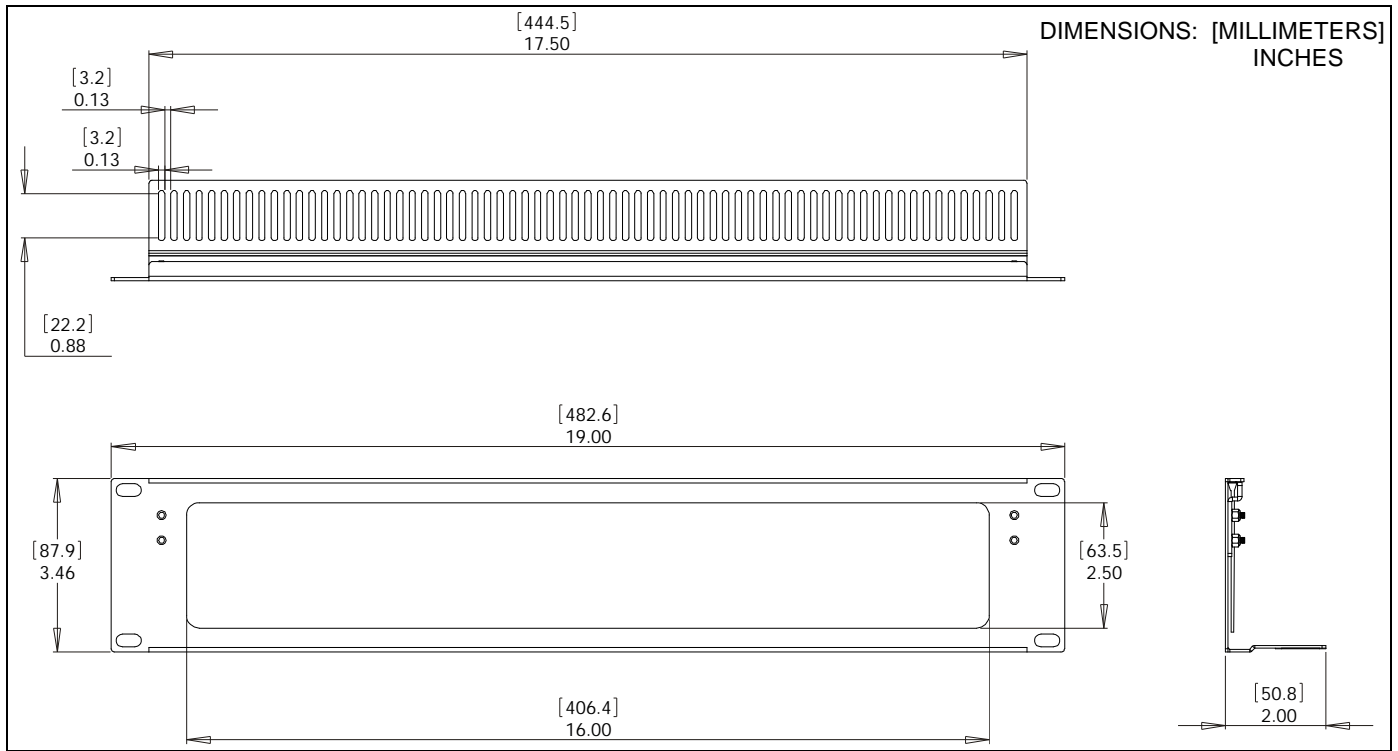

**TOOLS / HARDWARE / PARTS**

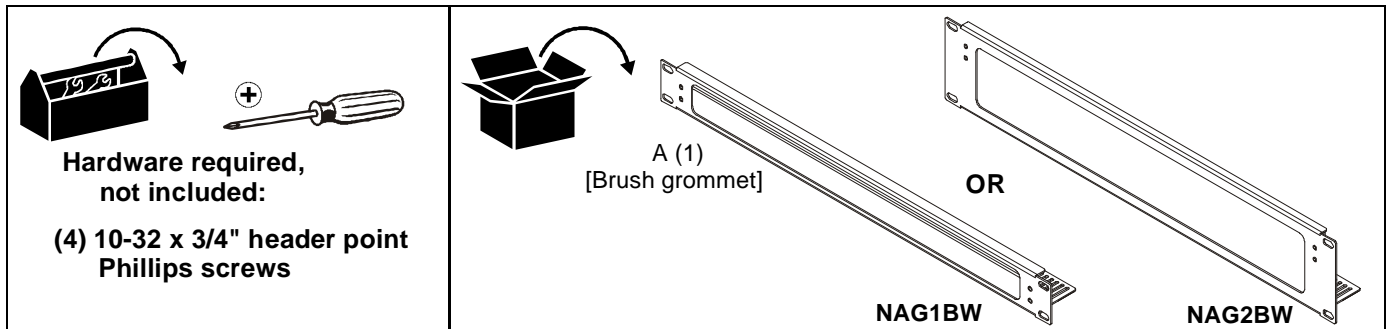

**ASSEMBLY AND INSTALLATION**

**NOTE:** The NAG1BW / NAG2BW brush grommets are designed for use with 19" wide equipment racks. See the specific installation instructions provided with the rack for additional installation information.

1. Attach the brush grommet (A) within the rack, using four 10-32 x 3/4" header point Phillips screws (not included). (See Figure 1)
2. Complete the installation following the rack installation instructions.

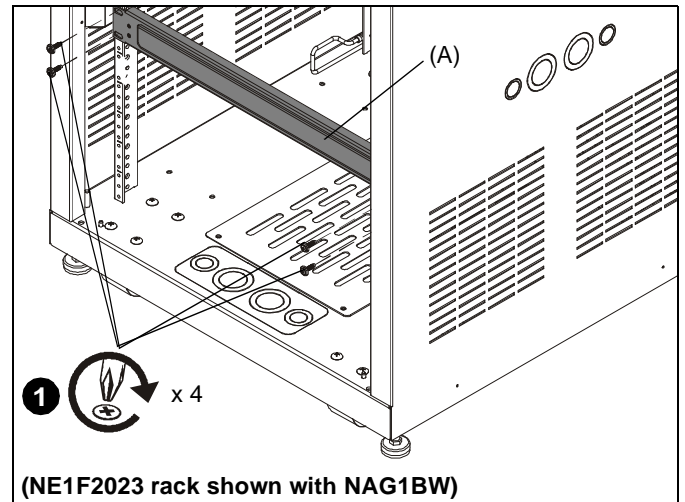

Figure 1



Our Mounts. **Your Vision.**

Chief Manufacturing, a products division  
of Milestone AV Technologies

8821-002005 Rev00  
©2010 Milestone AV Technologies, a  
Duchossois Group Company  
[www.chiefmfg.com](http://www.chiefmfg.com)  
09/10

<b>USA/International</b>	<b>A</b> 8401 Eagle Creek Parkway, Savage, MN 55378 <b>P</b> 800.582.6480 / 952.894.6280 <b>F</b> 877.894.6918 / 952.894.6918
<b>Europe</b>	<b>A</b> Fellenoord 130 5611 ZB EINDHOVEN, The Netherlands <b>P</b> +31 (0)40 2668620 <b>F</b> +31 (0)40 2668615
<b>Asia Pacific</b>	<b>A</b> Office No. 1 on 12/F, Shatin Galleria 18-24 Shan Mei Street Fotan, Shatin, Hong Kong <b>P</b> 852 2145 4099 <b>F</b> 852 2145 4477

