



**AUX2000
Auxiliary Control
Box**

**Installation/
Operation Manual**

C916M (11/90)

TABLE OF CONTENTS

<u>Section</u>	<u>Page</u>
1.0 WARNINGS	1
2.0 SCOPE	2
3.0 DESCRIPTION	2
3.1 MODEL NUMBERS	2
3.2 RECOMMENDED CONTROLS	2
4.0 INSTALLATION	3
4.1 MATING CONNECTOR ASSEMBLY	4
5.0 OPERATION	5
5.1 SYSTEM TEST	5
6.0 TROUBLESHOOTING GUIDELINES	5
7.0 AUX2000 MECHANICAL PARTS LIST	6
8.0 ELECTRICAL PARTS LIST	6
9.0 SCHEMATICS	7
10.0 SPECIFICATIONS	8
11.0 WARRANTY AND RETURN INFORMATION	10

LIST OF ILLUSTRATIONS

<u>Figure</u>	<u>Page</u>
1 Typical Output Circuits	3
2 Mating Connector Assembly Diagram	4
3 AUX2000 Schematics	7

®Pelco and the Pelco logo are registered trademarks of Pelco.
©Copyright 1990, Pelco. All rights reserved.

INSTALLATION/OPERATION MANUAL
AUX2000 AUXILIARY CONTROL BOX
FOR THE COAXITRON® AND
WIRETRON RECEIVER/DRIVER

1.0 WARNINGS

Prior to installation and use of this product, the following WARNINGS should be observed.

1. Installation and servicing should only be done by Qualified Service Personnel and conform to all Local codes.
2. Unless the unit is specifically marked as a NEMA Type 3, 3R, 3S, 4, 4X, 6 or 6P enclosure, it is designed for Indoor use only and it must not be installed where exposed to rain and moisture.
3. The product may bear the following marks:
 4. Only use replacement parts recommended by Pelco.
 5. After replacement/repair of this unit's electrical components, conduct a resistance measurement between line and exposed parts to verify the exposed parts have not been connected to line circuitry.
 6. The installation methods and materials should be capable of supporting four (4) times the weight of the AUX2000.

This symbol indicates that dangerous voltage constituting a risk of electric shock is present within this unit.



CAUTION:
TO REDUCE THE RISK OF ELECTRICAL SHOCK, DO NOT REMOVE COVER. NO USER-SERVICEABLE PARTS INSIDE. REFER SERVICING TO QUALIFIED SERVICE PERSONNEL.

This symbol indicates that there are important operating and maintenance instructions in the literature accompanying this unit.



CAUTION:
RISK OF ELECTRIC SHOCK.
DO NOT OPEN.

Please thoroughly familiarize yourself with the information in this manual prior to installation and operation.

2.0 SCOPE

The information contained within this manual covers the installation and operation of the AUX2000.

3.0 DESCRIPTION

The AUX2000 is an auxiliary control box for the Coaxitron® and Wiretron receiver/drivers. It enables the logic level AUX 1-3 signals from the Coaxitron® and Wiretron receiver/drivers to control devices such as motors for motor operated gates, lights for parking areas, or power relays for high power requirements.

3.1 MODEL NUMBERS

AUX2000 Auxiliary control box for the Coaxitron® and Wiretron receiver/drivers.

3.2 RECOMMENDED CONTROLS

CX9024RX Coaxitron® receiver in weatherproof box for 24 VAC pan/tilts, zoom lens, 24 VAC camera power, and four accessory functions.

CX9024RX-12V Same as CX9024RX except supplied with 12 VDC camera power.

CX9024RXI Coaxitron® receiver. Same as CX9024RX, except for indoor use.

CX9024RXI-12V Same as CX9024RXI except supplied with 12 VDC camera power.

CX9115RX Coaxitron® receiver in weatherproof box for 120 VAC pan/tilt, zoom lens, 120 VAC camera power, and four accessory functions.

CX9115RXI Same as CX9115RX except for indoor use.

CX9224RX Same as CX9024RX except with 24 VAC power input.

CX9224RXI Same as CX9224RX except for indoor use.

CX9224RXI-12V Same as CX9224RXI except with 12 VDC camera power.

WX8024RX Wiretron receiver in weatherproof box for 24 VAC pan/tilts, zoom lens, 24 VAC camera power, and four accessory functions.

WX8024RXI Same as WX8024RX except for indoor use.

WX8224RXI Same as WX8024RXI except with 24 VAC power input.

WX8115RX Wiretron receiver in weatherproof box for 120 VAC pan/tilts, zoom lens, 120 VAC camera power, and four accessory functions.

4.0 INSTALLATION

Refer to the following instructions when installing the AUX2000 auxiliary control box for the Coaxitron® and Wiretron receiver/drivers.

1. Determine the location for the AUX2000 auxiliary control box for the Coaxitron® or Wiretron receiver/drivers. To determine the mounting location, consider the distance between the AUX2000 auxiliary control box for the Coaxitron® and Wiretron receiver/drivers and auxiliary functions used. Attention should be given to the wire distance table shown above.
2. Using the AUX2000 auxiliary control box for the Coaxitron® and Wiretron receiver/drivers box as a template, mount the box to the desired location using the fasteners (not supplied) which will support the full load of the unit.
3. Assemble the mating connector as described in Section 4.1.
4. Connect the auxiliary device as shown in Figure 1.
5. Plug the AUX2000 into a 120 VAC source.

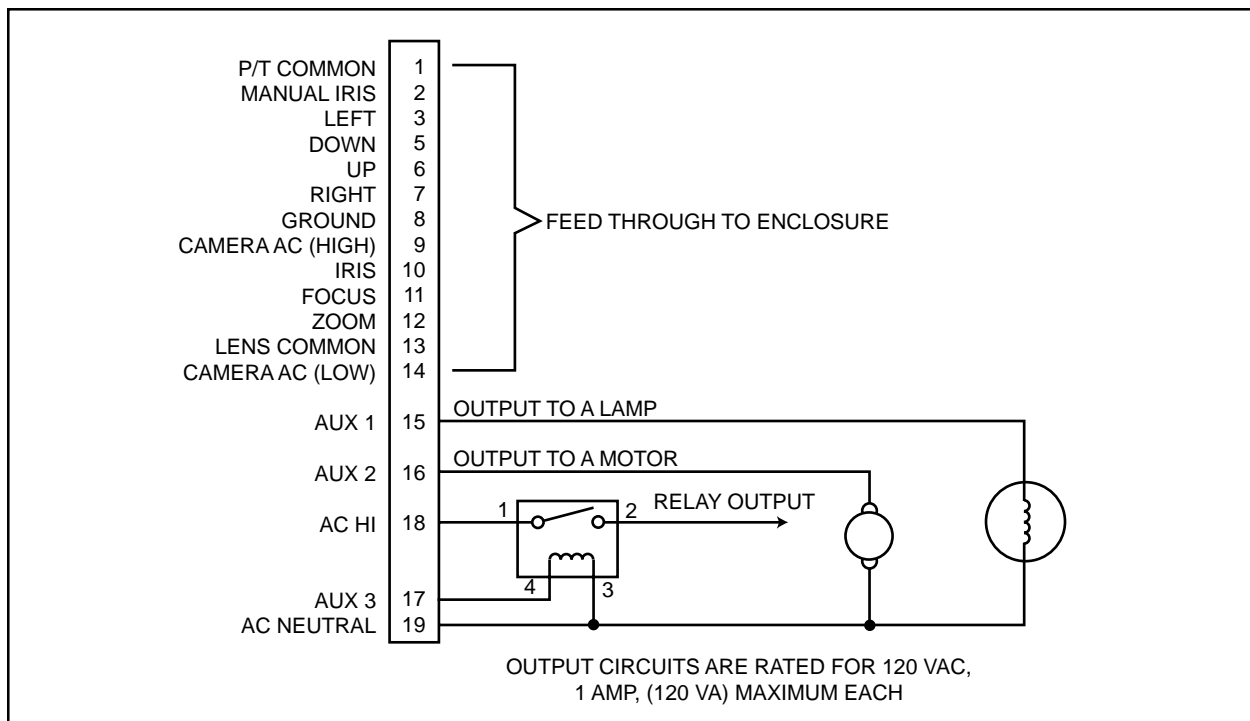

Figure 1. Typical Output Circuits

4.1 MATING CONNECTOR ASSEMBLY

Installation and/or testing will require you to assemble the connector parts provided. Fabricate the interconnecting cable according to the following steps (reference Figure 2).

1. Slide part A of the cable clamp (item 1) over the end of the cable (item 1, part C) with the threaded end of the cable clamp facing the connector (item 5).
2. If the cable has a diameter less than 1/2 inch (1.3 cm), slide the rubber boot (item 2) over the end of the cable and pull through the cable clamp to so that the boot encases the cable and forms a good seal.
3. Strip back the cable jacket approximately 1-1/4 inches (3.2 cm) and separate the individual conductors (item 3).

4. The contact pins supplied with the mating connector are the “crimp” type which may also be soldered if you so desired (item 4).
5. After crimping or soldering the contact pins to the conductors, push them into the proper holes in the connector until they snap in place.

NOTE: Contacts cannot be removed from the connector without the use of the appropriate AMP extraction tool which is available from Pelco.

6. Slide part A of the cable clamp toward the connector and screw the parts together. Attach part B (item 1) onto part A and connect both parts with the screws provided.
7. Connect the cable assembly to the unit and seat the connector by twisting the locking collar until it snaps into position.

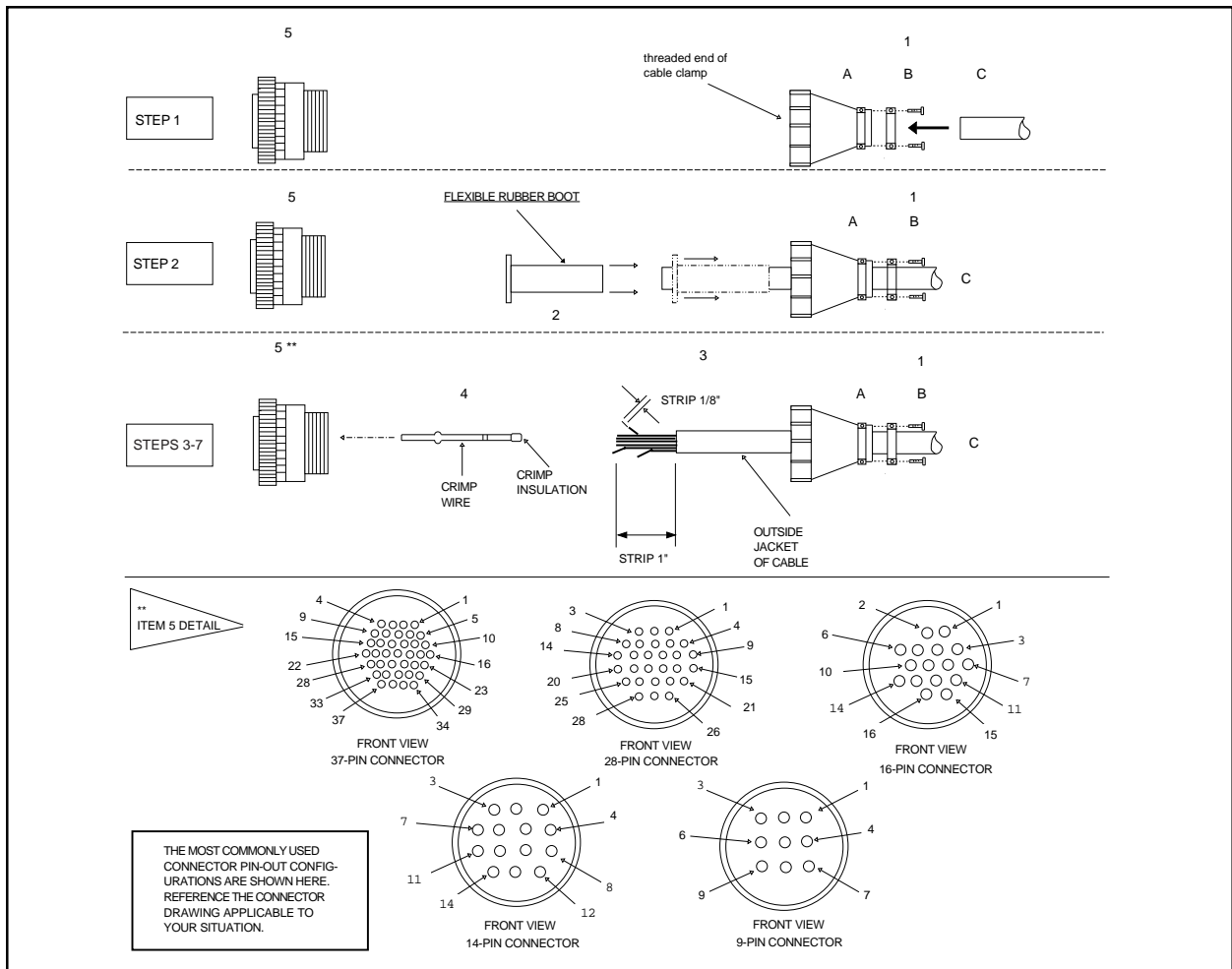

Figure 2. Mating Connector Assembly Diagram

5.0 OPERATION

The AUX2000 is operated by the Coaxitron® or Wiretron controller.

5.1 SYSTEM TEST

Using the systems controller, verify that the auxiliary devices function.

6.0 TROUBLESHOOTING GUIDELINES

In the event that the auxiliary equipment do not work, retrace the wiring and verify correctness and check the fuse to make sure it did not open.

Correct all errors in wiring and replace the fuse if opened.

Retry to operate the auxiliary equipment.

If the auxiliary equipment does still not operate, call Pelco's Technical Assistance Program (TAP) line at 1-800-289-9100. The TAP Line is available 24 hours a day, seven days a week.

7.0 AUX2000 MECHANICAL PARTS LIST

Description	Part Number
Enclosure	DS100JA4000COMP
Fuse holder	FUS357001
Terminal Strip	TRS20007
Strain Relief	EH5510043
Mating Connector (Sockets)	CONA37S
Mating Connector (Pins)	CONA37P

8.0 ELECTRICAL PARTS LIST

Schematic ID	Description	Part Number
CON1	Connector, 37 pins	CON206151-1
CON2-CON3	Connector, 6 position	CON640428-6
CON4-CON5	Connector, 2 position	CON640428-2
CON6	Connector, 37 sockets	CON206306-1
F1	Fuse, 3 AMP, 3AG	FUS3
L1-L3	Choke, 6.2 Microhenry's	CHO4610
Plug 1	Cord, 18 AWG, SJT	WIRC1318006BL
RY1-RY3	Relay, 120VAC, SPST	REL120A01MP

9.0 SCHEMATICS

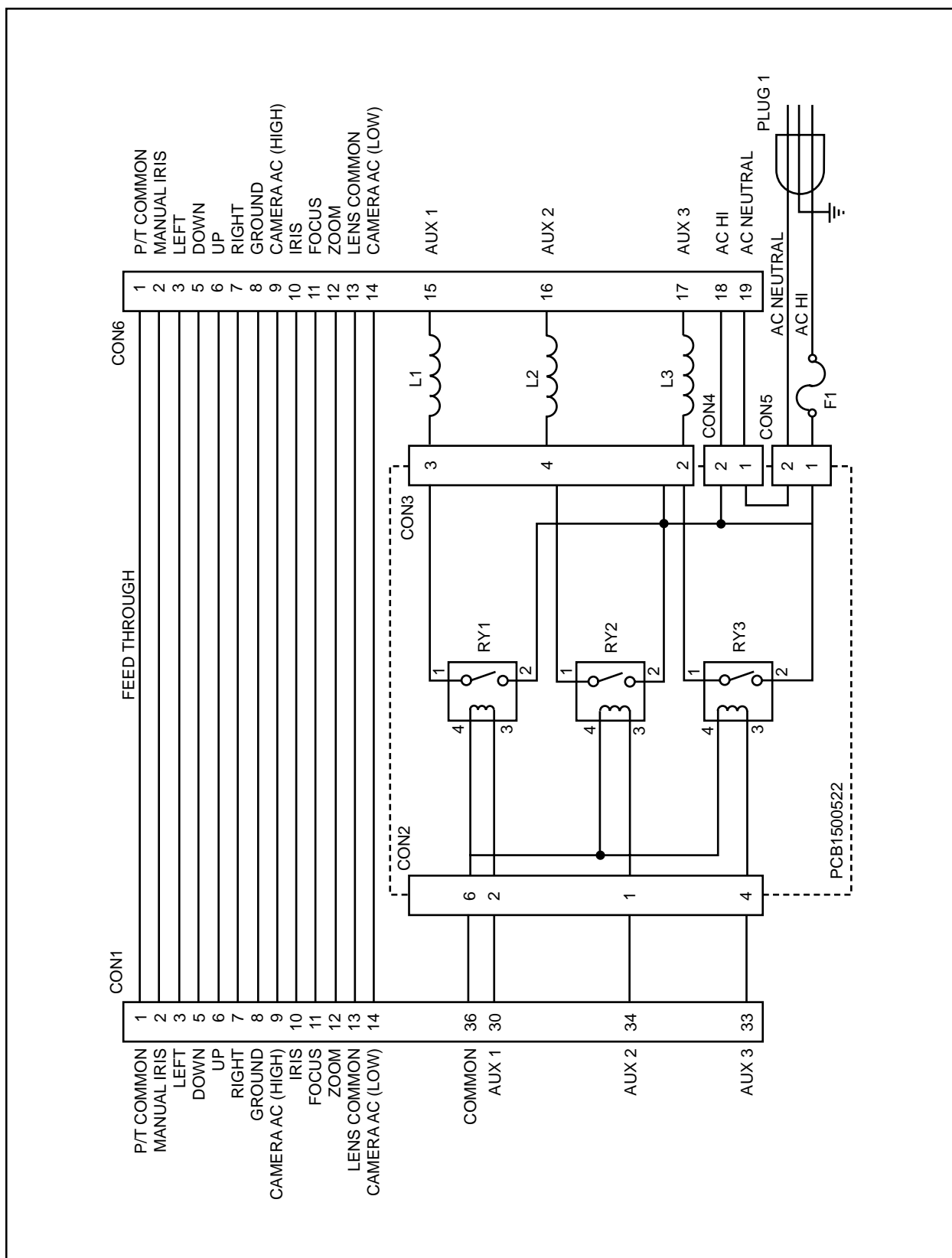

Figure 3. AUX2000 Schematics

10.0 SPECIFICATIONS

MECHANICAL

Enclosure: UL listed gray industrial control panel enclosure

Weatherproofing: Cover and connectors fully gasketed

Mounting Means: 6 - 0.31" (.79 cm) diameter holes

Dimensions: 11.31" H x 9.44" W x 4.32" D
(28.7 cm x 4.25 cm x 10.97 cm)

Unit Weight: 7 lbs (3.15 kg)

Shipping Weight: 9 lbs (36.45 kg)

ELECTRICAL

Input Voltage: 120 VAC

Power

Requirements: 360 VA

Power Cord: 18/3 AWG, listed SJT

Fuse Protection: 3 amp

Connectors: AMP CPC type

Conductor

Requirements: Minimum 20 AWG

Cable Distance:

Wire Gauge	Maximum Distance In Feet (meters) *	Maximum Distance In Feet (meters) **
16	495 (150.9)	1,490 (454.2)
18	310 (94.5)	940 (286.5)
20	195 (59.4)	590 (179.8)

* One amp load for each auxiliary function and one common neutral.

** One amp for each auxiliary function and one neutral conductor for each auxiliary function.

11.0 WARRANTY AND RETURN INFORMATION

WARRANTY

Pelco will repair or replace, without charge, any merchandise proved defective in material or workmanship for a period of one year after the date of shipment.

Exceptions to this warranty are as noted below:

- Five years on FT/FR8000 Series fiber optic products.
- Three years on Genex® Series products (multiplexers, server, and keyboard).
- Three years on Camclosure® and fixed camera models, except the CC3701H-2, CC3701H-2X, CC3751H-2, CC3651H-2X, MC3651H-2, and MC3651H-2X camera models, which have a five-year warranty.
- Two years on standard motorized or fixed focal length lenses.
- Two years on Legacy®, CM6700/CM6800/CM9700 Series matrix, and DF5/DF8 Series fixed dome products.
- Two years on Spectra®, Esprit®, ExSite™, and PS20 scanners, including when used in continuous motion applications.
- Two years on Esprit® and WW5700 Series window wiper (excluding wiper blades).
- Eighteen months on DX Series digital video recorders, NVR300 Series network video recorders, and Endura™ Series distributed network-based video products.
- One year (except video heads) on video cassette recorders (VCRs). Video heads will be covered for a period of six months.
- Six months on all pan and tilts, scanners or preset lenses used in continuous motion applications (that is, preset scan, tour and auto scan modes).

Pelco will warrant all replacement parts and repairs for 90 days from the date of Pelco shipment. All goods requiring warranty repair shall be sent freight prepaid to Pelco, Clovis, California. Repairs made necessary by reason of misuse, alteration, normal wear, or accident are not covered under this warranty.

Pelco assumes no risk and shall be subject to no liability for damages or loss resulting from the specific use or application made of the Products. Pelco's liability for any claim, whether based on breach of contract, negligence, infringement of any rights of any party or product liability, relating to the Products shall not exceed the price paid by the Dealer to Pelco for such Products. In no event will Pelco be liable for any special, incidental or consequential damages (including loss of use, loss of profit and claims of third parties) however caused, whether by the negligence of Pelco or otherwise.

The above warranty provides the Dealer with specific legal rights. The Dealer may also have additional rights, which are subject to variation from state to state.

If a warranty repair is required, the Dealer must contact Pelco at (800) 289-9100 or (559) 292-1981 to obtain a Repair Authorization number (RA), and provide the following information:

1. Model and serial number
2. Date of shipment, P.O. number, Sales Order number, or Pelco invoice number
3. Details of the defect or problem

If there is a dispute regarding the warranty of a product which does not fall under the warranty conditions stated above, please include a written explanation with the product when returned.

Method of return shipment shall be the same or equal to the method by which the item was received by Pelco.

RETURNS

In order to expedite parts returned to the factory for repair or credit, please call the factory at (800) 289-9100 or (559) 292-1981 to obtain an authorization number (CA number if returned for credit, and RA number if returned for repair).

All merchandise returned for credit may be subject to a 20% restocking and refurbishing charge.

Goods returned for repair or credit should be clearly identified with the assigned CA or RA number and freight should be prepaid. Ship to the appropriate address below.

If you are located within the continental U.S., Alaska, Hawaii or Puerto Rico, send goods to:

Service Department
Pelco
3500 Pelco Way
Clovis, CA 93612-5699

If you are located outside the continental U.S., Alaska, Hawaii or Puerto Rico and are instructed to return goods to the USA, you may do one of the following:

If the goods are to be sent by a COURIER SERVICE, send the goods to:

Pelco
3500 Pelco Way
Clovis, CA 93612-5699 USA

If the goods are to be sent by a FREIGHT FORWARDER, send the goods to:

Pelco c/o Expeditors
473 Eccles Avenue
South San Francisco, CA 94080 USA
Phone: 650-737-1700
Fax: 650-737-0933

Pelco, the Pelco logo, Camclosure, Esprit, Genex, Legacy, and Spectra are registered trademarks of Pelco.
Endura and ExSite are trademarks of Pelco.

© Copyright 1990, Pelco. All rights reserved.