

ULTRAFEX[®] PRO EX3200

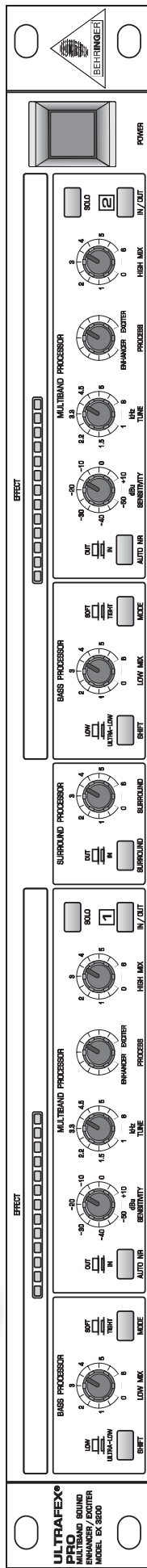

User's Manual Bedienungsanleitung

Version 1.1 May 1998



www.behringer.de



EG-Declaration of Conformity



Spezielle Studiotechnik GmbH

acc. to the Directives 89/336/EWG and 73/23/EWG

We, BEHRINGER INTERNATIONAL GmbH
Hanns-Martin-Schleyer-Straße 4
D - 47877 Willich

Name and address of the manufacturer or the introducer of the product on the market who is established in the EC

herewith take the sole responsibility to confirm that the product:

ULTRAFEX PRO EX3200

Type designation and, if applicable, Article-N°

which refers to this declaration, is in accordance with the following standards or standardized documents:

- | | |
|----------------------------------------------|--------------------------------------------------|
| <input checked="" type="checkbox"/> EN 60065 | <input checked="" type="checkbox"/> EN 61000-3-2 |
| <input checked="" type="checkbox"/> EN 55020 | <input checked="" type="checkbox"/> EN 61000-3-3 |
| <input checked="" type="checkbox"/> EN 55013 | |

The following operation conditions and installation arrangements have to be presumed:

acc. to Operating Manual

BEHRINGER
INTERNATIONAL GmbH
Hanns-Martin-Schleyer-Str. 36-38
D-47877 Willich, Mercurstraße II
Tel.-Nr. 0 21 54 / 92 06-0
Fax-Nr. 0 21 54 / 92 06-30

B. Nier, President

Willich, 01.05.1998

Name, address, date and legally binding signature of the person responsible

SAFETY INSTRUCTIONS

CAUTION: To reduce the risk of electrical shock, do not remove the cover (or back). No user serviceable parts inside; refer servicing to qualified personnel.



WARNING: To reduce the risk of fire or electrical shock, do not expose this appliance to rain or moisture.



This symbol, wherever it appears, alerts you to the presence of uninsulated dangerous voltage inside the enclosure - voltage that may be sufficient to constitute a risk of shock.



This symbol, wherever it appears, alerts you to important operating and maintenance instructions in the accompanying literature. Read the manual.

DETAILED SAFETY INSTRUCTIONS:

All the safety and operation instructions should be read before the appliance is operated.

Retain Instructions:

The safety and operating instructions should be retained for future reference.

Heed Warnings:

All warnings on the appliance and in the operating instructions should be adhered to.

Follow instructions:

All operation and user instructions should be followed.

Water and Moisture:

The appliance should not be used near water (e.g. near a bathtub, washbowl, kitchen sink, laundry tub, in a wet basement, or near a swimming pool etc.).

Ventilation:

The appliance should be situated so that its location or position does not interfere with its proper ventilation. For example, the appliance should not be situated on a bed, sofa rug, or similar surface that may block the ventilation openings; or placed in a built-in installation, such as a bookcase or cabinet that may impede the flow of air through the ventilation openings.

Heat:

The appliance should be situated away from heat sources such as radiators, heat registers, stoves, or other appliance (including amplifiers) that produce heat.

Power Source:

The appliance should be connected to a power supply only of the type described in the operating instructions or as marked on the appliance.

Grounding or Polarization:

Precautions should be taken so that the grounding or polarization means of an appliance is not defeated.

Power-Cord Protection:

Power supply cords should be routed so that they are not likely to be walked on or pinched by items placed upon or against them, paying particular attention to cords and plugs, convenience receptacles and the point where they exit from the appliance.

Cleaning:

The appliance should be cleaned only as recommended by the manufacturer.

Non-use Periods:

The power cord of the appliance should be unplugged from the outlet when left unused for a long period of time.

Object and Liquid Entry:

Care should be taken so that objects do not fall and liquids are not spilled into the enclosure through openings.

Damage Requiring Service:

The appliance should be serviced by qualified service personnel when:

- The power supply cord or the plug has been damaged; or
- Objects have fallen, or liquid has been spilled into the appliance; or
- The appliance has been exposed to rain; or
- The appliance does not appear to operate normally or exhibits a marked change in performance; or
- The appliance has been dropped, or the enclosure damaged.

Servicing:

The user should not attempt to service the appliance beyond that is described in the Operating Instructions. All other servicing should be referred to qualified service personnel.



ULTRAFEX PRO

Professional and multi-purpose Sound Enhancement system for stage and studio applications

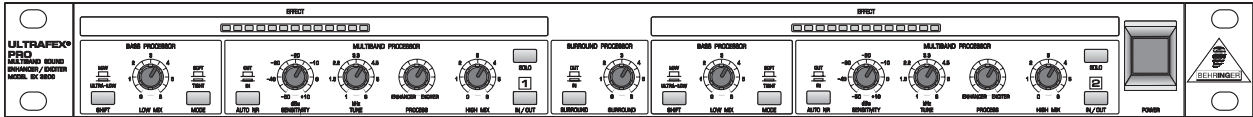

- ▲ Gives your music that extra sparkle and makes your instruments or mixes stand out
- ▲ Releases untapped resources and details instruments, vocals and mixed program material
- ▲ Multiband concept for bass power and high frequency transparency
- ▲ “Natural Sonic” processor for ultra-musical sound improvement
- ▲ VSP (Variable Sound Processing) circuit for simultaneous Enhancer and Exciter process
- ▲ “Dual Mode” ultra-bass enhancer produces “soft” and “tight” bass sounds
- ▲ Shift function allows you to control the frequency range of added bass punch
- ▲ Surround processor provides you real spatial enhancement and improved stereo imaging
- ▲ Built-in Noise Reduction system with precision LED display to provide clear visual indication of operation
- ▲ Solo facility for effect loop application
- ▲ Servo-balanced gold-plated XLR and 1/4” TRS inputs and outputs
- ▲ Ultra-low noise 4580 audio operational amplifiers for superior sound performance
- ▲ Relay controlled Hard Bypass with an auto-bypass function during power failure (failsafe relay)
- ▲ High-quality detent potentiometers and illuminated switches
- ▲ BEHRINGER’s high-performance output transformer OT-1 retrofittable
- ▲ Manufactured under the stringent ISO9000 management system

FOREWORD

Dear Customer,

Welcome to the team of ULTRAFEX PRO users and thank you very much for expressing your confidence in BEHRINGER products by purchasing this unit.

It is one of my most pleasant tasks to write this letter to you, because it is the culmination of many months of hard work delivered by our engineering team to reach a very ambitious goal: making an outstanding device better still. The ULTRAFEX has for quite a long time been a standard tool used by numerous studios and P.A. rental companies. The task to improve one of our best-selling products certainly meant a great deal of responsibility, which we assumed by focusing on you, the discerning user and musician. It also meant a lot of work and night shifts to accomplish this goal. But it was fun, too. Developing a product usually brings a lot of people together, and what a great feeling it is when everybody who participated in such a project can be proud of what we've achieved.

It is our philosophy to share our joy with you, because you are the most important member of the BEHRINGER family. With your highly competent suggestions for new products you've greatly contributed to shaping our company and making it successful. In return, we guarantee you uncompromising quality (manufactured under ISO9000 certified management system) as well as excellent technical and audio properties at an extremely favorable price. All of this will enable you to fully unfold your creativity without being hampered by budget constraints.

We are often asked how we can make it to produce such high-grade devices at such unbelievably low prices. The answer is quite simple: it's you, our customers! Many satisfied customers means large sales volumes enabling us to get better conditions of purchase for components, etc. Isn't it only fair to pass this benefit back to you? Because we know that your success is our success, too!

I would like to thank all people whose help on "Project ULTRAFEX PRO" has made it all possible. Everybody has made very personal contributions, starting from the designers of the unit via the many staff members in our company to you, the user of BEHRINGER products.

My friends, it's been worth the trouble!

Thank you very much,

A handwritten signature in black ink, appearing to read 'U. Behringer', with a long horizontal flourish extending to the right.

Uli Behringer



TABLE OF CONTENT

1. INTRODUCTION	7
2. THE DESIGN CONCEPT	9
2.1 High Quality Components And Design	9
2.1.1 Failsafe Relays	9
2.2 Inputs And Outputs	9
2.2.1 Balanced Inputs And Outputs	9
2.2.2 Transformer Balanced Outputs (Optional)	9
3. INSTALLATION	10
3.1 Rack Mounting	10
3.2 Mains Voltage	10
3.3 Audio Connections	10
4. CONTROLS	12
4.1 The Multiband Processor Section	12
4.2 The Bass Processor Section	13
4.3 Surround Processor Section	13
4.4 Rear Panel Control Elements Of The ULTRAFEX PRO	14
5. TECHNICAL BACKGROUND	15
5.1 Design Concept Of The ULTRAFEX PRO	15
5.2 Psycho-Acoustic Background	15
5.3 On Psycho-Acoustic Devices	16
5.3.1 Frequency Correction	16
5.3.2 Phase Shifting	16
5.3.3 Artificial Harmonics Generation	17
5.4 The Bass Processor Of The ULTRAFEX PRO	17
5.5 The Surround Processor Of The ULTRAFEX PRO	17
6. APPLICATIONS	18
6.1 Basic Applications	18
6.1.1 The ULTRAFEX PRO As "In-Line" Processor	18
6.1.2 The ULTRAFEX PRO As "Sidechain" Processor	18
6.2 Basic Settings	19
6.3 Typical Applications	20
6.3.1 Sound Enhancement During Replay	20
6.3.2 Sound Enhancement During Recording	20
6.3.3 Enhancing The Sound Of Subgroups, Monitor And Effect Paths	20
6.3.5 Enhancing The Sound Of Tape Duplication	20
6.3.6 Enhancing The Sound Of Instruments	21
6.3.7 Enhancing The Sound Of P.A. Systems	21
6.3.9 Sound Enhancement In Hi-fi And Video	21
7. SPECIFICATIONS	22
8. WARRANTY	24

1. INTRODUCTION

In purchasing the new ULTRAFEX PRO Model EX3200, you have acquired an extremely efficient and universal sound enhancement processor. The sound precision and flexibility of the functions are the main outstanding features of this high-end unit.

The ULTRAFEX PRO is our state-of-the-art sound enhancement system offering a special combination of sound improvement designs. The unit can be used wherever professional sound improvement is required. The BEHRINGER ULTRAFEX PRO is the no-compromise answer when the situation demands a no-compromise solution.

Advanced BEHRINGER Technology

Since its announcement of the first ULTRAFEX model in year 1990, it has caused a sensation. This high-end sound enhancement processor is based on our many years of experience and discoveries in the field of psycho-acoustics. The ULTRAFEX PRO finds widespread application throughout the world, in renowned studios, sound reinforcement systems as well as in broadcast and TV studios.

The task to improve our famous ULTRAFEX PRO II was a big challenge. We are very proud that we succeeded. Compared to its predecessors, the ULTRAFEX PRO offers several advanced features and we have succeeded in dramatically refining the audio qualities. The unit features now a "Mode" function which enables you to select either a soft and warm bass sound or a super-tight bass. Beside that a new VSP (Variable Sound Processing) circuitry has been added to allow you to use simultaneous Exciter and Enhancer sound processing.

Since the introduction of the first psycho-acoustic processors, technology in this field has made tremendous progress. Although the fundamental principles of enhancer and exciter technology have been well-known for a long time, engineers have been able to refine and improve the essential components over and over again. The BEHRINGER company has also contributed considerably to this development:

With the introduction of our Natural Sonic processor, we have set new standards. Previously encountered problems of restricted leveling range, plus increased noise level and audible distortion during signal processing, are typical shortcomings of conventional circuit designs. They were completely solved by the development of new circuitry.

Sophisticated Manufacturing and Quality Assurance System

For the first time, the ULTRAFEX PRO EX3200 uses SMD technology (Surface Mounted Device). These sub-miniature components known from aerospace technology allow for an extreme packing density, plus improve the unit's reliability.

The BEHRINGER Natural Sonic Processor: Sound Enhancement Of Classical And Pop Music

The BEHRINGER Natural Sonic principle is based on frequency-selective phase shifting in conjunction with program-dependent equalization and pulse enlargement. An automatic and natural correction during signal processing offers a quality of sound enhancement that has been almost inconceivable until now. Program-dependent control permits the "musical" and unobtrusive transparency required for classical music material, yet also provides the necessary brilliance for pop recordings. Owing to its dynamic control, and in contrast with conventional units, the circuitry does NOT introduce any additional noise, non-related harmonics or distortion.

The VSP (Variable Sound Processing) Circuit

The new VSP (Variable Sound Processing) circuit used for the first time in the ULTRAFEX PRO, allows for variably fading over from Enhancer to Exciter mode. Using the PROCESS control clockwise, the Exciter circuit comes in additionally to provide a variable and carefully adjusted processing of high frequencies. The result is an increased brilliance and transparency. Fading over from one effect to the other can thus adapt the effects perfectly to the respective program material.

Built-in Noise Reduction System

Due to physical reasons, Exciters and Enhancers principally increase noise of the processed program material. Therefore, we have incorporated a switchable noise reduction system which is capable of automatically fading out any additional noise.



Bass Processor

The ULTRAFEX PRO is equipped with a separate bass processor which allows for sound enhancement in the lower frequency band. A newly developed "Dual Mode" circuit allows you to vary between two different bass sounds from "soft" to "tight".

Processing the bass range means an optimum completion of high-frequency processing and opens up new dimensions in the field of sound processing.

Surround-Processor

A switchable Surround Processor has also been integrated into the ULTRAFEX PRO. With this processor the intensity of the stereo effect can be dramatically improved. The program material gains in liveliness, depth and transparency. As in a cinema with its special acoustics, the listener has the impression that the orchestral instruments are placed all around him. The Surround Processor enlarges the stereo basis, dependent on the program material, without audibly coloring the sonic image.

 **The following operational manual will introduce you to the BEHRINGER ULTRAFEX PRO and its various functions. After reading the manual carefully, make sure it is always on hand for future reference.**

2. THE DESIGN CONCEPT

2.1 High Quality Components And Design

The philosophy behind BEHRINGER products guarantees a no-compromise circuit design and employs the best choice of components. The operational amplifiers NJM4580 which are used in the ULTRAFEX PRO, are exceptional. They boast extreme linearity and very low distortion characteristics. The most important aspect of the ULTRAFEX PRO design is a radical VCA implementation which results in outstanding technical specification and excellent performance. To complement this design the choice of components includes high tolerance metalfilm resistors and capacitors, detent potentiometers and several other stringently selected elements.

For the first time, the ULTRAFEX PRO EX3200 uses SMD technology (Surface Mounted Device). These sub-miniature components known from aerospace technology allow for an extreme packing density, plus the unit's reliability could be improved. Additionally, the unit is manufactured in compliance with a ISO9000 certified management system.

2.1.1 Failsafe Relays

Failsafe relays have been incorporated into the design of the BEHRINGER ULTRAFEX PRO, which automatically and silently bypass the unit in the event of power supply disconnection or failure. These relays are also active at switch-on to isolate the ULTRAFEX PRO until the power rails have settled, thus preventing the possibility of a potentially damaging switch-on thump.

2.2 Inputs And Outputs

2.2.1 Balanced Inputs And Outputs

As standard, the BEHRINGER ULTRAFEX PRO is installed with electronically servo-balanced inputs and outputs. The new circuit design features automatic hum and noise reduction for balanced signals and thus allows for trouble-free operation, even at high operating levels. Externally induced mains hum etc. will be effectively suppressed. The automatic servo-function recognizes the presence of unbalanced connectors and adjusts the nominal level internally to avoid level differences between the input and output signals (correction 6 dB).

2.2.2 Transformer Balanced Outputs (Optional)

In contrast to electronic balancing, the use of transformer-balanced outputs offers the advantage of galvanic separation between units. Electrical potential differences and ground loops in audio installations do not therefore impair the performance of the units. The transformer-balanced outputs, commonly used in radio and TV engineering, can also be fitted retrospectively upon request. The BEHRINGER transformer OT-1 is designed to the highest exacting standards and is available as an accessory.



3. INSTALLATION

Your BEHRINGER ULTRAFEX PRO was carefully packed in the factory and the packaging was designed to protect the unit from rough handling. Nevertheless, we recommend that you carefully examine the packaging and its contents for any signs of physical damage, which may have occurred in transit.

 **If the unit is damaged, please do not return it to us, but notify your dealer and the shipping company immediately, otherwise claims for damage or replacement may not be granted. Shipping claims must be made by the consignee.**

3.1 Rack Mounting

The BEHRINGER ULTRAFEX PRO fits into one standard 19" rack unit of space (1 3/4"). Please allow at least an additional 4" depth for the connectors on the back panel. Be sure that there is enough air space around the unit for cooling and please do not place the ULTRAFEX PRO on high temperature devices such as power amplifiers etc. to avoid overheating.

3.2 Mains Voltage

Before you connect your ULTRAFEX PRO to the mains, please make sure that your local voltage matches the voltage required by the unit! The fuse holder on the female mains connector has 3 triangular markers, with two of these triangles opposing each other. Your ULTRAFEX PRO is set to the operating voltage printed next to these markers, and can be set to another voltage by turning the fuse holder by 180°. **CAUTION: this instruction does not apply to export models exclusively designed, e.g. for 115 V operation!**

3.3 Audio Connections

The audio inputs and outputs on the BEHRINGER ULTRAFEX PRO are fully balanced. If possible, connect the unit to other devices in a balanced configuration to allow for maximum interference immunity.

 **Please ensure that only qualified persons install and operate the ULTRAFEX PRO. During installation and operation the user must have sufficient electrical contact to earth. Electrostatic charges might affect the operation of the ULTRAFEX PRO!**

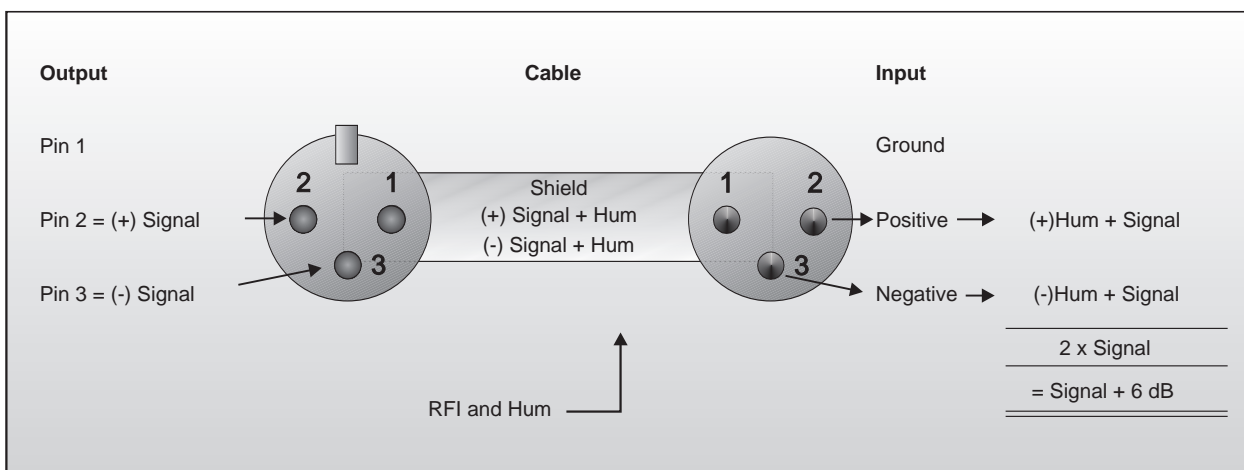

Fig. 3.1: Compensation of interference with balanced connections

Critical applications may require to build up a transformer-balanced configuration for the output signals, so as to avoid interference from ground loops or potential differences. For this purpose, we offer our high-quality output transformer OT-1 as a retrofit kit.

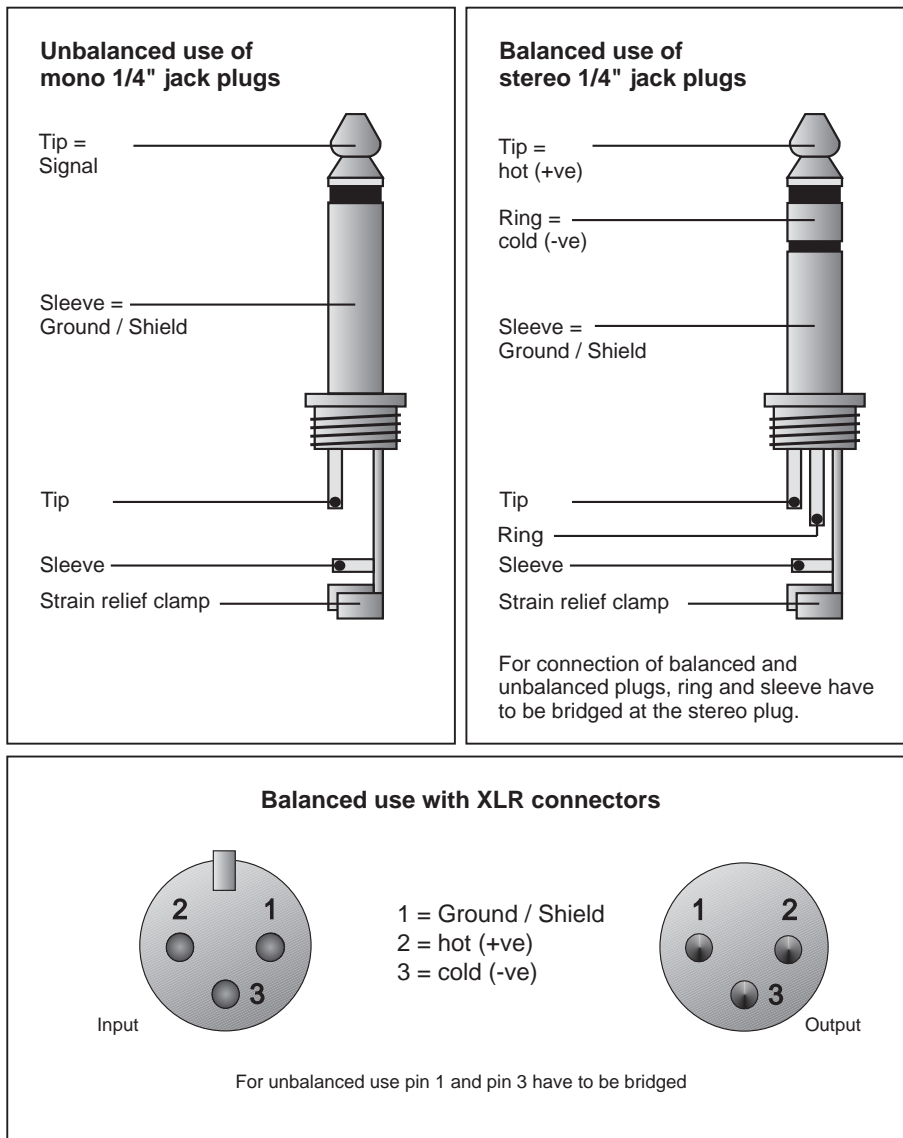

Fig. 3.2: Different plug types

 **Never use unbalanced XLR connections with microphone cables, as this would short-circuit any phantom power transmitted over these cables!**

4. CONTROLS

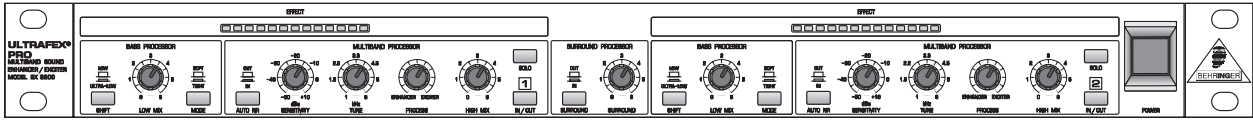

Fig. 4.1: ULTRAFEX PRO front panel

The BEHRINGER ULTRAFEX PRO has two identical channels and provides 5 illuminated push-button switches, 5 rotary controls, and 13 LEDs per channel.

4.1 The Multiband Processor Section

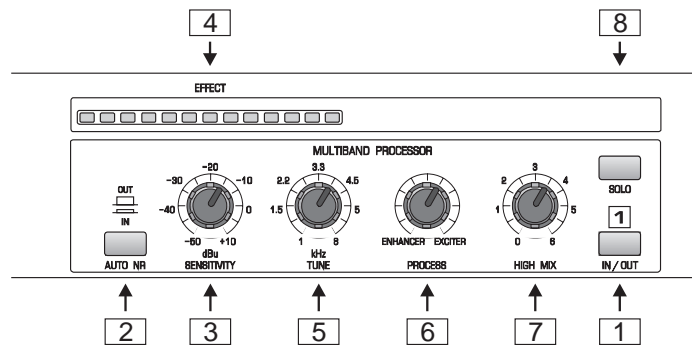





Fig. 4.2: Controls of the Multiband Processor section

- 1 The *IN/OUT* switch activates the relay and puts the corresponding channel into operation. With the switch in the *OUT* position, the unit is bypassed.
 - 2 The *AUTO NR* switch (*AUTO NOISE REDUCTION*) activates the automatic noise reduction system. If the switch is not depressed, the section is switched off and the unit operates with maximum effect.
 - 3 The *NR SENSITIVITY* control adapts the sensitivity of the Natural Sonic processor to the input level of the program material. The subsequent *EFFECT* meter helps you to adjust the *NR SENSITIVITY* control.
 - 4 In conjunction with the *NR SENSITIVITY* control, these thirteen *EFFECT* meter LEDs provide correct level indication for the unit. The LEDs display the amount of sound enhancement.
-  **Please make sure, that the sensitivity of the unit is high enough especially at low-level signals. Otherwise audible pumping may occur. The first LED should always be illuminated even at low-level signals and should only go off when the music stops.**
- 5 The *TUNE* control sets the lower cutoff frequency of the high-pass filter. Using this control you can select the frequencies that are routed to the Natural Sonic processor. The cut-off frequency can be adjusted within a range of 1 to 8 kHz.
 - 6 The *PROCESS* control determines the function of the device. When turning the control in clockwise direction, the *Exciter* function is activated, which increases the signal's transparency and sharpness. Consequently, the ULTRAFEX PRO can be adapted to the program material, to suit the application on hand as well as any personal sound preferences.
-  **Please note that with classical program material, acoustic instruments or with output signals that already include sufficient treble frequencies, the “Enhancer” setting should be preferred. However, when processing, for instance, a “slapped” bass guitar, it is the “Exciter” setting which should dominate.**



- 7 The *HIGH MIX* control of the high band determines the amount of signal used for sound enhancement (from zero to six). It would depend on the application as to whether a high-quality system is to be given the “finishing touch” with the ULTRAFEX PRO, or whether maximum intelligibility is to be achieved in a relatively poor sound reinforcement system.
 - 8 When the *SOLO* switch is depressed, the unit operates in solo mode and separates the pure effect signal from the main signal. Thus, the BEHRINGER ULTRAFEX PRO may be used as a “sidechain” processor (cf. chapter 7.1.2 “The ULTRAFEX PRO As “Sidechain” Processor”).
-  **Please note that pre-monitoring of the solo signal will only allow for a rather restricted evaluation of the sound, since this signal only provides sound enhancement if it is combined with the original signal.**

4.2 The Bass Processor Section

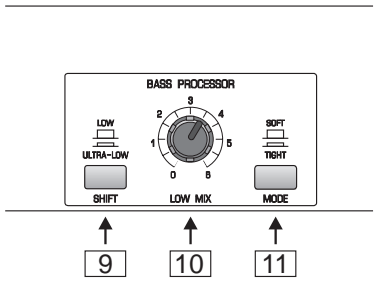



Fig. 4.3: Controls of the Bass Processor section

- 9 The *SHIFT* switch determines the cut-off frequency of the bass processor. Depending on the program material, you can select between “Low” and “Ultra-low”.
 - 10 The *LOW MIX* control of the low band determines the amount of signal used for sound enhancement (from zero to six). The setting depends on the application you are addressing.
-  **Please note that the bass processor should be set carefully to avoid possible speaker damage. Most near-field monitors are not capable of handling the bass produced by the ULTRAFEX PRO.**
- 11 With the *MODE* switch you can define the sound effect of the bass processor. If the switch is on (“Tight”) the bass will sound “dry” and “punchy”, whereas the released switch mode (“Soft”) creates a warm and full bass.

4.3 Surround Processor Section

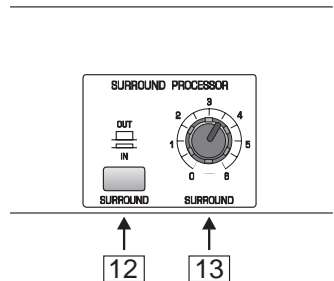

Fig. 4.4: Controls of the Surround Processor section

- 12 With the *SURROUND* switch you can activate the Surround section. Please note that this switch has to be released if you want to process two separate input signals. Otherwise there will be undesired cross-talk between the two channels.

- 13 The *SURROUND* control determines the effect of the surround processor. This function serves to improve the intensity of the stereo effect and to enlarge the stereo basis dependent on the program content. Therefore, this function can only be used in conjunction with stereo program material.

4.4 Rear Panel Control Elements Of The ULTRAFEX PRO

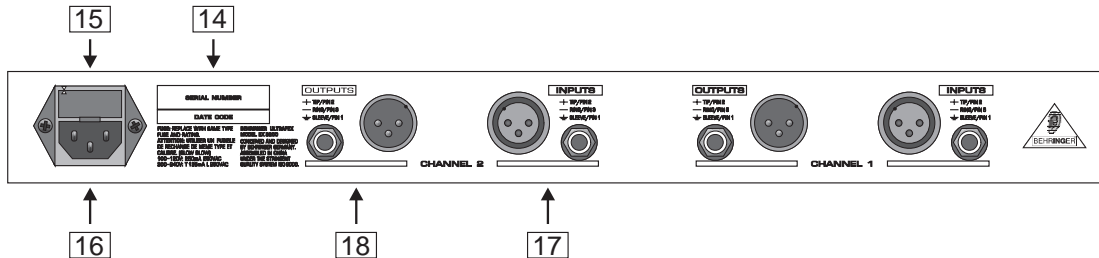

Fig. 4.5: Control elements of the rear panel

- 14 **SERIAL NUMBER.** Please take the time to have the warranty card filled out completely by your specialized dealer, and return it within 14 days after the date of purchase, so as to be entitled to benefit from our extended warranty.
- 15 **FUSE HOLDER / VOLTAGE SELECTOR.** Please make sure that your local voltage matches the voltage indicated on the unit, before you attempt to connect and operate the ULTRAFEX PRO. Blown fuses may only be replaced by fuses of the same type and rating.
- 16 **MAINS CONNECTION.** Use the enclosed power cord to connect the unit to the mains. Please also note the instructions given in the "INSTALLATION" chapter.
- 17 **AUDIO IN.** These are the audio inputs of your ULTRAFEX PRO, available both as balanced 6.3 mm jack and XLR connectors.
- 18 **AUDIO OUT.** These are the audio outputs of your ULTRAFEX PRO. Matching phone jack and XLR connectors are wired in parallel. These outputs can be transformer-balanced by retrofitting the optional output transformer OT-1.

5. TECHNICAL BACKGROUND

5.1 Design Concept Of The ULTRAFEX PRO

The BEHRINGER ULTRAFEX PRO...

- ▲ increases presence and transparency. The program material will sound lively and natural again.
- ▲ improves the intelligibility of speech: voices become clearly articulated, text easily intelligible, the transparency of the vocal increases.
- ▲ provides a distinct sound improvement, particularly for instruments played in a percussive style - "slapped" guitars or drums will sound incredibly "funky".
- ▲ provides better stereo imaging: the sound becomes more differentiated, speaker setup poses less problems, yet the signal remains fully mono-compatible.
- ▲ does not require any decoding process, since sound enhancement with the BEHRINGER ULTRAFEX PRO is not created independently of the signal itself, and remains available even during numerous processing or copying stages. Even digital recordings or CD replaying will gain from the use of the BEHRINGER ULTRAFEX PRO.
- ▲ increases the listener's awareness. Even with low sound pressure levels, the ULTRAFEX PRO avoids listening fatigue.
- ▲ finds useful application in Hi-fi systems by providing better resolution of the sonic image, due to its suitability for the studio and its outstanding specifications. In particular, the processing of old analogue recordings (disks and tapes) proves to be very efficient with the ULTRAFEX PRO.
- ▲ produces a more powerful and fuller bass which does not sound muddy. All recordings will benefit from the "dry" and precisely defined bass contouring.
- ▲ produces an improved spatial enhancement and stereo effect intensity with the surround processor without audibly colouring the sonic image.

5.2 Psycho-Acoustic Background

The term psycho-acoustics refers to the psychological aspect of hearing - in contrast to the physiological transfer of impulses (transmission of nervous impulses). Psycho-acoustics examines the effect of sound on the listener and the reasons for certain sonic impressions. How a sound is interpreted is influenced by a lot of factors, most of them can hardly be measured yet are fairly important. For instance, those portions which are responsible for the spatial localization of a sound. Nevertheless, they determine the quality of a recording to an extraordinarily large extent.

There are also portions of the audio spectrum which we perceive as "presence" or "naturalness". If this kind of information is missing, the recording suffers from a loss in "freshness", "liveliness" and spatial transparency.

Furthermore, natural harmonics are essential components of the sound. Often enough, they only represent a minor portion of the signal and are easily lost. It's the harmonic structure that makes a tone colour unique. Without this structure, different instruments would not be distinguishable. When comparing acoustic musical instruments, for instance acoustic guitars, you will note that even two instruments from the same series have a different sound. Numerous factors determine the sound of an instrument: the design and materials to name but two, but with such bearing on the eventual sound produced by that instrument.

From a physical point of view, a guitar produces a tone by means of a vibrating string which, in turn, sets air in motion. The subsequent propagating sound waves reach the ear and are identified by the brain as a tone. Since the string vibrates within itself, the tone consists of not only the fundamental oscillation but also innumerable upper harmonics which are based on the fundamental wave.

The complex vibrations of the string are transferred to the body which, in turn, is also set in motion. The combination of string and body produces the sound of the instrument. For example, certain harmonics may be amplified due to resonance effects in the body, while other frequencies may be canceled due to the properties of the wood.



This phenomenon creates complex sounds and is underlined by the fact that a combination of harmonics can produce additional tones, known as interference or residual tones. All of these tiny sound portions contribute to the sound of certain instruments. The human ear, which is highly sensitive, can detect even minimum changes in the harmonic structure of a sound.

By experiencing the CD quality of 18 bit-converters etc., we have made considerable advances toward the naturalness of sound, yet still recordings do not sound like the music in a concert hall. Why is there a difference?

Here, the keyword is "intelligent hearing": the visual contact with the musicians enables us to concentrate our attention on a certain instrument which results in an intensification of the sonic experience. The listener sitting in front of a speaker system lacks this spatial experience and at the same time the visual feedback aspect of listening to live music. The perceived positioning of instruments is made even more difficult since the dispersion of the sound is not homogeneous, i.e., widely panoramic, but usually reduced to two sound sources.

In particular, the loss of upper harmonics during the transmission of the sound additionally affects the perceived positioning of the instruments and the transmission of room ambiance. The reason for this loss in sound quality is the inadequacy of the sound recording and reproduction processes.

Each link in the transmission chain - from the microphone via mixers, effects devices, tape recorders amplifiers etc., to the loudspeakers - causes a loss in sound quality. Each time the sound is processed, it becomes audibly less "natural".

5.3 On Psycho-Acoustic Devices

In the field of what is known as psycho-acoustics, numerous terms such as enhancer, exciter, psycho-acoustic processor, psycho-dynamic processor, clarifier etc., are commonly used. What do these terms actually mean? The following chapter will shed some light on this.

Although the psycho-acoustic effect of enhancers and exciters etc., has been known for several decades, the function of these devices has been deliberately surrounded in mystique, to increase their appeal.

However, it is fairly clear that all devices in this field are based on certain technically repeatable methods of functioning. Basically, three principles apply:

- ▲ Sound improvement by means of dynamic frequency correction.
- ▲ The generation of a "wider" sound with the help of phase shifting with respect to delay times.
- ▲ The enrichment of the program material with artificially generated harmonics.

Independently of each other, each of these methods produces a certain effect which is perceived as a subjective enhancement within the sound.

These methods are described in more detail in the following:

5.3.1 Frequency Correction

The boosting or cutting of certain frequency ranges is the simplest form of sound modification. Equalizers can correct the sonic image in order to produce a sound that is more pleasing to each taste.

So-called "treble boosters" achieve this effect by emphasizing the high frequencies, which the listener perceives as a transparent sonic image.

Within the BEHRINGER ULTRAFEX PRO, any frequency correction is combined with a frequency-dependent phase shift, which results in a sound that is "warmer" and more musical.

5.3.2 Phase Shifting

The term phase shift describes the displacement of a signal's phase in relation to its point of origin. As a matter of principle, the phase shift produces a delay within the signal.

If the delayed signal is added to the original signal, the resultant signal becomes "wider". Below time delay values of 20 msec. the brain perceives the delayed arrival of the two signals as the arrival of one signal, which results in the desired "pulse enlargement" effect, sometimes called "3-D" effect by other manufacturers.

The effect produced by so-called “chorus” units is based on the same principle of phase shift and signal delay. Here, several delayed signals are added to evenly intensify this effect.

The BEHRINGER ULTRAFEX PRO is equipped with a frequency-selective phase shift circuit that comprises several stages. Due to the program-dependent delayed signal, the sonic impression becomes more vivid, as with an orchestra, where the musical liveliness is the result of inaccurate “entries” by musicians.

5.3.3 Artificial Harmonics Generation

By 1955 an American, Charles D. Lindridge, had already invented the first “EXCITER” (a unit that EXCITES upper harmonics), when he presented a unit for “improving the sound of music and speech”. He enriched signal sources with artificially generated upper harmonics and found that both sound quality, transparency and perceived positioning of musical instruments could be considerably improved using this effect. He was granted an American patent on his circuit design under the number US 2 866 849.

Compared to modern technology, Lindridge’s circuit was anything but fully developed, however, it featured many of the aspects found in today’s modern circuit designs.

Psycho-acoustic discoveries and greater knowledge, gathered over the years, have allowed for new and improved circuit designs, through the use of advanced technology.

5.4 The Bass Processor Of The ULTRAFEX PRO

Apart from processing the upper harmonic ranges, users of the BEHRINGER ULTRAFEX PRO have access to an innovative bass processor.

The numerous stages of processing during the recording, reproduction, copying and effecting processes, increasingly delay the phase of the bass frequencies, when compared to the remaining frequency ranges. This is why the low-frequency range suffers from a loss in power and fundamental bass definition.

With the help of frequency-selective phase shift combined with sub-bass boost, the bass processor of the BEHRINGER ULTRAFEX PRO is capable of compensating for this loss, giving the program material new bass presence. Using the MODE switch, you can select between two different bass sounds.

Be extremely careful when using the bass processor: excessive use of the bass processor might lead to speaker damage. The amplified sub-bass frequencies may well place a heavy load on the amplifier and the woofers. Therefore, carefully adjust the bass processor and observe the power rating of your system!

5.5 The Surround Processor Of The ULTRAFEX PRO

Sound quality during signal transmission is given top priority today. The signal is processed with the help of reverb devices, compressors, exciters, denoisers etc. to produce a compact, low-noise and transparent sound.

However, the fact that hearing impression depends largely upon the positioning of the instruments within the stereo panorama is often enough neglected. Using the surround processor of the ULTRAFEX PRO, the intensity of the stereo effect can be dramatically improved. The program material gains in liveliness, loudness and transparency. As in a cinema with its special acoustics, the listener has the impression that the orchestral instruments are placed all around him. The surround processor enlarges the stereo basis dependent on the program material, without audibly colouring the sonic image.

The function of the surround processor is based on the derivation of a special signal, which is generated from the difference of the left and right channel. This signal is then delayed program dependently and mixed with the original signal. The difference between the two channels is the “stereo substance” whose ambient and spatial information is improved by delaying the signal.

Due to the described function, the surround processor is principally useful only with stereo program material.



6. APPLICATIONS

6.1 Basic Applications

6.1.1 The ULTRAFEX PRO As “In-Line” Processor

The BEHRINGER ULTRAFEX PRO provides two methods of system configuration:

Fig. 6.1 shows the use of the BEHRINGER ULTRAFEX PRO in a series configuration. In most cases, the unit will be used as an “in-line” effects device, by connecting it in series with other devices, or by inserting it into the “line inserts” of a mixer.

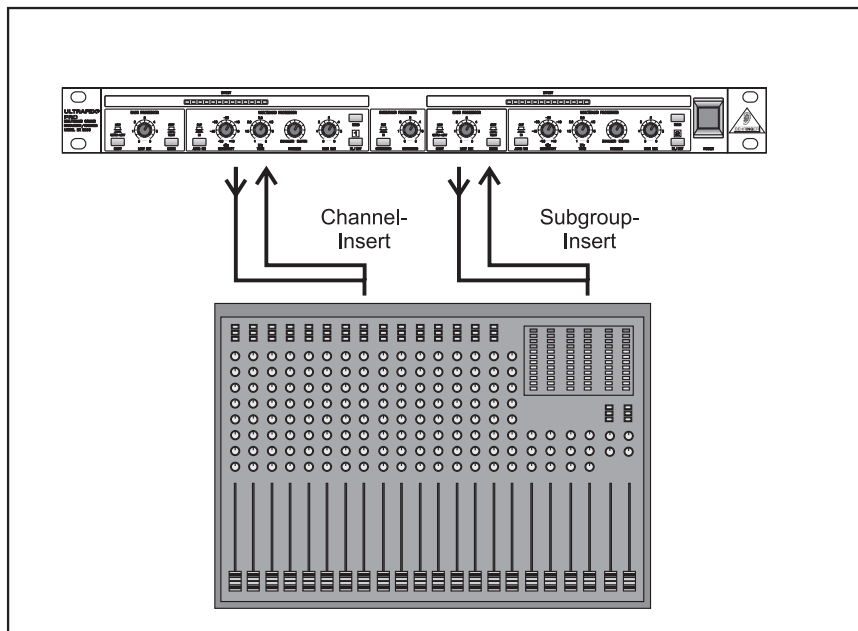

Fig. 6.1: Using the ULTRAFEX PRO as “in-line” processor

6.1.2 The ULTRAFEX PRO As “Sidechain” Processor

The following illustration shows the BEHRINGER ULTRAFEX PRO used as a “sidechain” or parallel effects device. By depressing the SOLO switch, the original signal is muted and the pure effect signal is available separately.

Use the SOLO switch, for instance, to insert the BEHRINGER ULTRAFEX PRO in the effects path of a mixer.

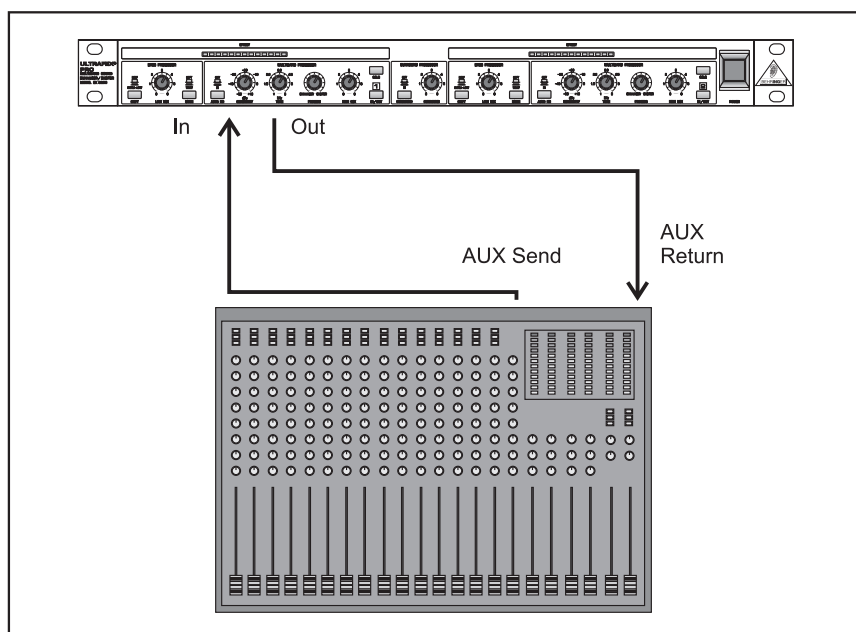

Fig. 6.2: Using the ULTRAFEX PRO as “sidechain” processor

Within a “sidechain” scenario, the original signal must be muted by depressing the SOLO switch, so that phase cancellations (comb filter effects) and additional noise will be effectively avoided.

Pre-monitoring of the solo signal will only allow for a rather restricted evaluation of the sound, since this signal only provides sound enhancement if combined with the original signal.

6.2 Basic Settings

We recommend setting the controls as indicated in the following three sections. This will give you a better idea of switch and control functionality:

1. Set the BEHRINGER ULTRAFEX PRO to bypass mode (IN/OUT switch not depressed), the TUNE controls to center position and all switches to their OUT position.
2. Turn all other controls fully CCW and depress both IN/OUT switches. Now turn the MIX controls of the low and high-frequency sections slowly clockwise until the fundamental bass and high frequencies become more emphasized and the sonic image begins to “open up” or to “widen”.
3. The quality of the sound enhanced signal can be adapted to the program material by varying the cut-off frequency using the SHIFT and MODE switches and/or the TUNE and PROCESS controls.
4. Now switch in the noise reduction section by depressing the AUTO NR switch and adjust the NR SENSITIVITY controls so that the first LED lights up, even with low signal levels and all LEDs are fully illuminated with loud signals.

👉 Please note that the NR SENSITIVITY control does NOT have the same effect as the DRIVE control on other exciters. This control is not effecting the Natural Sonic processor, but controlling the filter circuit which is responsible for noise-reduction. Excessively high sensitivity will not produce audible distortion, however, the noise level might increase during signal pauses.

When using enhancers or exciters it is easy to get carried away. Therefore, we recommend regular A/B comparisons (IN/OUT) while setting the controls, in order to constantly check the signals integrity.

Rule of thumb: the enhancer’s effect only should be noticeable when it is lacking, but not when it is present!

Listening at high volume levels over long periods (in studios, for example) leads to listening fatigue and thus reduces sensitivity to higher frequencies. Regular pauses keep your hearing “healthy” and exaggerated sound processing should be avoided.

6.3 Typical Applications

In this section we will discuss a few typical applications of the BEHRINGER ULTRAFEX PRO:

6.3.1 Sound Enhancement During Replay

For this application, the BEHRINGER ULTRAFEX PRO follows the master or multi-track recorder, i.e., inserted between tape machine and mixer (or amplifier). Of course, a cassette recorder, or similar, can also be used as signal source. If a companding noise reduction system is used in this situation, it should precede the BEHRINGER ULTRAFEX PRO.

6.3.2 Sound Enhancement During Recording

The sound enhancing effect can be increased by using the BEHRINGER ULTRAFEX PRO not only during replay but during recording. This method of sound processing is recommended, in particular, if the subsequent storage medium is of poor quality. When doing tape duplications, the enhancer signal added during the recording will compensate for the loss in quality which occurs when several generations of copies are made from the master tape.

In this scenario, insert the BEHRINGER ULTRAFEX PRO directly after the master output of the mixer into the recording path of the master or multi-track machine. Set up the unit as described in section "Sound Enhancement During Replay".

In particularly difficult cases, we recommend using the BEHRINGER ULTRAFEX PRO both during recording and replay.

6.3.3 Enhancing The Sound Of Subgroups, Monitor And Effect Paths

For this application there are several options:

1. If your mixer features subgroup outputs with insert points, you can process the subgroups separately.
2. You can also combine monitor and effect paths and route them via the BEHRINGER ULTRAFEX PRO to a free input channel. The respective signals have to be taken "pre-fader", the respective channels must be muted. It will be useful to insert the BEHRINGER ULTRAFEX PRO as the last component in the chain of effects devices. The summed signals will then be routed through the ULTRAFEX PRO, and sent back to the master via the "effect returns".

With the SOLO switch depressed, the channels need not be muted. Set up the mix as usual with the faders and determine which "monitor" or "effect send" controls the signal portions to be routed to the BEHRINGER ULTRAFEX PRO. With the help of the "effect return" control you can adjust the amount of the sound enhancing signal which is added to the summed signals.

Be sure that the SOLO switch is in the IN position for this kind of application, since the combination of original signals via the summed, as well as the effects path, may lead to phase cancellations (comb filter effect).

A detailed description of the SOLO switch and its function can be found in chapter 7.1.2 "The ULTRAFEX PRO As "Sidechain" Processor".

6.3.5 Enhancing The Sound Of Tape Duplication

Even under the most favourable of conditions, presence, liveliness and transparency of the program material will suffer during each copying process. These losses are particularly obvious when copying cassettes while simultaneously using a noise reduction system.

With the BEHRINGER ULTRAFEX PRO, losses during tape duplication can be avoided or compensated for. Provided that the original is of good enough quality with only low noise levels. It is even possible to produce "super" copies which sound even better than the original.

For this purpose, the BEHRINGER ULTRAFEX PRO is inserted between the line outputs of the source machine and the inputs of the target machine. Machines with post-head listening control (setting "tape") allow you to check the quality of the copy while duplicating the tape.

If the tape noise is fairly high, a different strategy is required, since the BEHRINGER ULTRAFEX PRO can effectively process the frequency ranges in which the most predominant noise portions can be found. We



recommend attenuation of noisy high frequencies, either with an equalizer or - better still - with a “single-ended” noise reduction system. The BEHRINGER ULTRAFEX PRO will process those frequencies with all their natural clarity - but without the tape noise.

We would like to point out in this section that the BEHRINGER company offers a series of extremely powerful noise reduction systems - the DENOISER series. The noise produced by magnetic tapes or any other signal sources can be dramatically reduced with the BEHRINGER DENOISER. Not only the noise produced by mixers, effects devices etc., but also by synthesizers, guitars etc., can be effectively reduced. Copied tapes and cassettes will benefit from low noise and high dynamics.

The ULTRAFEX PRO when used in conjunction with the BEHRINGER DENOISER will prove an ideal combination for sound enhancement. Please contact us for further information!

6.3.6 Enhancing The Sound Of Instruments

The bandwidth of most electronic musical instruments is limited by its “sampling rate”. The BEHRINGER ULTRAFEX PRO can improve the sound, so that synthesizers, samplers and drum machines have a more natural and transparent sound.

With the BEHRINGER ULTRAFEX PRO even tiny details within the sound of acoustic musical instruments such as guitars etc., can be emphasized without affecting the overall sound of the instrument. Drum instruments such as toms, bass drums etc., benefit from a “punch” and thus achieve a more powerful, precise and defined sound.

Please note that low-level signal sources such as microphones, guitars etc. should pass through a preamplifier before the processing stage, since the BEHRINGER ULTRAFEX PRO is a line-level device (-20 to +10 dBu).

6.3.7 Enhancing The Sound Of P.A. Systems

If used in P.A. and other sound reinforcement systems for background or live music, the BEHRINGER ULTRAFEX PRO offers astounding advantages:

1. In audio systems for announcements and background music, the BEHRINGER ULTRAFEX PRO is placed in a similar way to recording and tape duplication - directly before the power amp. The intelligibility and range of your system will be improved and the sonic image will become clear and transparent, even at low volume levels. Problems caused by background noise fluctuations, room acoustics (reflections), and speaker setup can be solved more easily.

For instance, in discos or clubs you do not need to constantly readjust the high frequencies as the place becomes increasingly crowded; you will be able to protect your speaker system and the hearing of visitors.

Background music in bars and restaurants can be heard easily. It does not annoy your guests because its volume had to be turned up too far.

2. The sound of any P.A. system will be improved by using the BEHRINGER ULTRAFEX PRO. For example, the vocals of music groups or speech transmissions will be considerably more transparent and intelligible, the instruments can be distinguished more easily. The bass will gain in “depth” and power.

The BEHRINGER ULTRAFEX PRO will increase the speaker systems’ acoustic performance and its ability to penetrate a room, particularly in places with difficult acoustics.

The system also needs less effective amplifier power, since the subjectively heard volume level increases. Powerful and detailed sound reproduction can also be achieved in “weak” systems. It helps that you do not have to spend a small fortune on upgrading your system.

6.3.9 Sound Enhancement In Hi-fi And Video

Of course, the BEHRINGER ULTRAFEX PRO can also find applications in the fields of hifi and video. The unit is simply placed between the signal source (cassette recorder, tuner, VCR etc.) and the power amplifier. We recommend using the “tape monitor” inputs most preamplifiers provide, thus the BEHRINGER ULTRAFEX PRO can be switched into any signal source.

7. SPECIFICATIONS

AUDIO INPUT

Connectors	XLR and 1/4" jack
Type	RF filtered, servo balanced input
Impedance	50 kOhms balanced, 25 kOhm unbalanced
Max. Input Level	+21 dBu balanced and unbalanced (unity gain)
CMRR	typ. 40 dB, >55 dB @ 1 kHz

AUDIO OUTPUT

Connectors	XLR and 1/4" jack
Type	Electronically servo-balanced output stage (optional transformer-balanced). Automatic level correction for unbalanced use (6 dB).
Impedance	60 Ohms balanced, 30 Ohm unbalanced
Max. Output Level	+21 dBu, +20 dBm balanced and unbalanced

SYSTEM SPECIFICATIONS

Bandwidth	20 Hz to 20 kHz, +0/-0.5 dB
Frequency Response	0.35 Hz to 200 kHz, +0/-3 dB
Noise	>-95 dBu, unweighted, 22 Hz to 22 kHz
THD	0.008 % typ. @ +4 dBu, 1 kHz, Gain 1 0.04 % typ. @ +20 dBu, 1 kHz, Gain 1
IMD	0.01 % typ. SMPTE
Crosstalk	<-100 dB, 22 Hz to 22 kHz

BASS PROCESSOR

Type	"Dual Mode" Bass Processor
Low Mix	variable (0 to 6)

MULTIBAND PROCESSOR

Type	"Natural Sonic" processor with VSP (Variable Sound Processing)
NR Sensitivity	variable (0 to 6)
Tune	variable (1 to 8 kHz)
Process	variable (Enhancer to Exciter)
High Mix	variable (0 to 6)

SURROUND SECTION

Surround	variable (0 to 6)
----------	-------------------

FUNCTION SWITCHES AND CONTROLS

Shift	Switches the frequency of the Bass Processor between "Low" and "Ultra-Low"
Mode	Switches the bass sound from "Soft" to "Tight"
Auto NR	Activates the noise reduction system
In/Out	Activates the relay controlled hard-bypass
Solo	Monitors the pure effect signal (Solo function)
Surround	Activates the surround processor

INDICATORS

Effect	13 LED meter indicates the effect
Function switch	LED indicator for each function switch

POWER SUPPLY

Mains voltages	USA/Canada	~ 120 V AC, 60 Hz
	U.K./Australia	~ 240 V AC, 50 Hz
	Europe	~ 230 V AC, 50 Hz
	General Export Model	~ 100-120 V AC, ~ 200-240 V AC, 50-60 Hz
Fuse	100-120 V AC:	250 mA (slow-blow)
	200-240 V AC:	125 mA (slow-blow)
Power consumption	5 Watts	
Mains connection	standard IEC receptacle	

PHYSICAL

Dimension	1 3/4" (44.5 mm)H * 19" (482.6 mm) * 8 1/2" (217 mm)
Net Weight	2.2 kg
Shipping Weight	3.4 kg

BEHRINGER is constantly striving to maintain the highest professional standards. As a result of these efforts, modifications may be made from time to time to existing products without prior notice. Specifications and appearance may differ from those listed or shown.

Any repair carried out by unauthorized personnel will void the warranty. Products which do not meet the terms of this warranty will be repaired exclusively at the buyer's expense. BEHRINGER INTERNATIONAL will inform the buyer of any such circumstance. If the buyer fails to submit a written repair order within 4 weeks after notification, BEHRINGER INTERNATIONAL will return the unit C.O.D. with a separate invoice for freight and packing. Such cost will also be invoiced separately when the buyer has sent in a written repair order.

§ 5 WARRANTY TRANSFERABILITY

This warranty is extended exclusively to the original buyer (customer of retail dealer) and is not transferable to anyone who may subsequently purchase this product. No other person (retail dealer, etc.) shall be entitled to give any warranty promise on behalf of BEHRINGER INTERNATIONAL.

§ 6 CLAIM FOR DAMAGES

Failure of BEHRINGER INTERNATIONAL to provide proper warranty service shall not entitle the buyer to claim (consequential) damages. In no event shall the liability of BEHRINGER INTERNATIONAL exceed the invoiced value of the product.

§ 7 OTHER WARRANTY RIGHTS

This warranty does not exclude or limit the buyer's statutory rights provided by national law, in particular, any such rights against the seller that arise from a legally effective purchase contract.



8. WARRANTY

§ 1 WARRANTY CARD

To be protected by this warranty, the buyer must complete and return the enclosed warranty card (signed/stamped by retail dealer) within 14 days of the date of purchase to BEHRINGER INTERNATIONAL (address see § 3). Failure to return the card in due time (date as per postmark) will void any extended warranty claims.

§ 2 WARRANTY

1. BEHRINGER INTERNATIONAL warrants the mechanical and electronic components of this product to be free of defects in material and workmanship for a period of one (1) year from the original date of purchase, in accordance with the warranty regulations described below. If any defects occur within the specified warranty period that are not caused by normal wear or inappropriate use, BEHRINGER INTERNATIONAL shall, at its sole discretion, either repair or replace the product.

2. If the warranty claim proves to be justified, the product will be returned freight prepaid by BEHRINGER INTERNATIONAL within Germany. Outside of Germany, the product will be returned at the buyer's expense.

3. Warranty claims other than those indicated above are expressly excluded.

§ 3 RETURN AUTHORIZATION NUMBER

1. To obtain warranty service, the buyer must call BEHRINGER INTERNATIONAL during normal business hours BEFORE returning the product (Tel.: +49 (0) 21 54 / 92 06 66). All inquiries must be accompanied by a description of the problem. BEHRINGER INTERNATIONAL will then issue a return authorization number.

2. The product must be returned in its original shipping carton, together with the return authorization number, to the following address:

BEHRINGER INTERNATIONAL GmbH
Service Department
Hanns-Martin-Schleyer-Str. 36-38
D - 47877 Willich-Münchheide

3. Shipments without freight prepaid will not be accepted.

§ 4 WARRANTY REGULATIONS

1. Warranty services will be furnished only if the product is accompanied by an original retail dealer's invoice. Any product deemed eligible for repair or replacement by BEHRINGER INTERNATIONAL under the terms of this warranty will be repaired or replaced within 30 days of receipt of the product at BEHRINGER INTERNATIONAL.

2. If the product needs to be modified or adapted in order to comply with applicable technical or safety standards on a national or local level, in any country which is not the country for which the product was originally developed and manufactured, this modification/adaptation shall not be considered a defect in materials or workman-

ship. The warranty does not cover any such modification/adaptation, irrespective of whether it was carried out properly or not. Under the terms of this warranty, BEHRINGER INTERNATIONAL shall not be held responsible for any cost resulting from such a modification/adaptation.

3. Free inspections, maintenance/repair work and replacement of parts are expressly excluded from this warranty, in particular if caused by inappropriate use. Likewise, the warranty does not cover defects of expendable parts caused by normal wear of the product. Expendable parts are typically faders, potentiometers, switches and similar components.

4. Damages/defects caused by the following conditions are not covered by this warranty:

- ▲ misuse, neglect or failure to operate the unit in compliance with the instructions given in the user or service manuals.
- ▲ connection or operation of the unit in any way that does not comply with the technical or safety regulations applicable in the country where the product is used.
- ▲ damages/defects that are caused by force majeure or by any other condition beyond the control of BEHRINGER INTERNATIONAL.

5. Any repair carried out by unauthorized personnel will void the warranty.

6. Products which do not meet the terms of this warranty will be repaired exclusively at the buyer's expense. BEHRINGER INTERNATIONAL will inform the buyer of any such circumstance. If the buyer fails to submit a written repair order within 4 weeks after notification, BEHRINGER INTERNATIONAL will return the unit C.O.D. with a separate invoice for freight and packing. Such cost will also be invoiced separately when the buyer has sent in a written repair order.

§ 5 WARRANTY TRANSFERABILITY

This warranty is extended exclusively to the original buyer (customer of retail dealer) and is not transferable to anyone who may subsequently purchase this product. No other person (retail dealer, etc.) shall be entitled to give any warranty promise on behalf of BEHRINGER INTERNATIONAL.

§ 6 CLAIM FOR DAMAGES

Failure of BEHRINGER INTERNATIONAL to provide proper warranty service shall not entitle the buyer to claim (consequential) damages. In no event shall the liability of BEHRINGER INTERNATIONAL exceed the invoiced value of the product.

§ 7 OTHER WARRANTY RIGHTS

This warranty does not exclude or limit the buyer's statutory rights provided by national law, in particular, any such rights against the seller that arise from a legally effective purchase contract.

The information contained in this manual is subject to change without notice. No part of this manual may be reproduced or transmitted in any form or by any means, electronic or mechanical, including photocopying and recording of any kind, for any purpose, without the express written permission of BEHRINGER GmbH.

BEHRINGER and ULTRAFEX are registered trademarks. ALL RIGHTS RESERVED © 1999 BEHRINGER.
BEHRINGER INTERNATIONAL GmbH, Hanns-Martin-Schleyer-Str. 36-38, D-47877 Willich-Münchheide II
Tel. +49 (0) 21 54 / 92 06-0, Fax +49 (0) 21 54 / 92 06-30
