

OWNER'S GUIDE

• ASSEMBLY • OPERATION • MAINTENANCE •

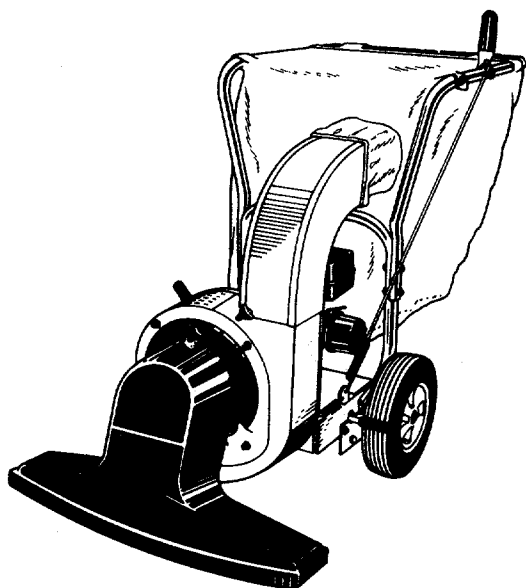

POWER VACUUMS

Model Series
675 thru 689

IMPORTANT!

Record the **Model No.** and **Mfg. Code** which appear on your unit in the space below. You **must** have these numbers, along with the date of purchase, in order to receive warranty or service.

MEETS ANSI SAFETY STANDARDS

MODEL NO.

MFG. CODE

**Important:
Read Safety Rules
and Instructions Carefully**



Made
in
AMERICA

WARNING: This unit is equipped with an internal combustion engine and should not be used on or near any unimproved forest-covered, brush-covered or grass-covered land unless the engine's exhaust system is equipped with a spark arrester meeting applicable local or state laws (if any). If a spark arrester is used, it should be maintained in effective working order by the operator.

In the State of California the above is required by law (Section 4442 of the California Public Resources Code). Other states may have similar laws. Federal laws apply on federal lands. A spark arrester for the muffler is available through your nearest engine authorized service dealer or contact the service department, P.O. Box 368022, Cleveland, Ohio 44136-9722.

IMPORTANT

RULES FOR SAFE OPERATION



THIS SYMBOL POINTS OUT IMPORTANT SAFETY INSTRUCTIONS WHICH, IF NOT FOLLOWED, COULD ENDANGER THE PERSONAL SAFETY AND/OR PROPERTY OF YOURSELF AND OTHERS. READ AND FOLLOW ALL INSTRUCTIONS IN THIS MANUAL BEFORE ATTEMPTING TO OPERATE YOUR POWER VACUUM. FAILURE TO COMPLY WITH THESE INSTRUCTIONS MAY RESULT IN PERSONAL INJURY. WHEN YOU SEE THIS SYMBOL— **HEED ITS WARNING.**



DANGER: Your power vacuum was built to be operated according to the rules for safe operation in this manual. As with any type of power equipment, carelessness or error on the part of the operator can result in serious injury. If you violate any of these rules, you may cause serious injury to yourself or others.

1. Read this operating and service instruction manual carefully. Be thoroughly familiar with the controls and proper use of the power vacuum.
2. Never allow children to operate this power vacuum.
3. Keep the area of operation clear of all persons, particularly small children and pets.
4. Check fuel before starting engine. Do not fill fuel tank indoors, when engine is running, or while engine is hot. Wipe off any spilled fuel before starting engine.
5. Do not change engine governor settings.
6. Do not put hands near rotating parts for any reason.
7. If the power vacuum should start to vibrate abnormally, stop the engine and check immediately for the cause. Vibration is generally a warning of trouble.
8. Before cleaning, repairing or inspecting, make certain all moving parts have come to a complete stop. Disconnect spark plug wire and keep wire away from plug to prevent accidental starting. Also keep throttle control lever in the stop position.
9. If the power vacuum should become blocked with debris at any point, shut engine off and wait until the impeller comes to a complete stop before attempting to remove the obstruction. Disconnect spark plug wire to prevent accidental starting.
10. Check all bolts for tightness at frequent periods.
11. Never store this power vacuum with fuel in the tank. Allow engine to cool before storing in any enclosure.
12. Keep bag and equipment free of debris when not in use.
13. Never operate this power vacuum unless air duct and vacuum bag are properly affixed in their place. Large zippered end of bag must be closed when operating to prevent objects from being blown out.
14. Never empty vacuum bag when engine is running.
15. Never change inlet nozzle or auxiliary hose attachment when engine is running.
16. The manufacturer recommends that the operator wear safety glasses or some other suitable eye protection when operating this machine.
17. Check the vacuum bag frequently for wear and replace when necessary.
18. Never operate as a leaf blower unless impeller guard and guard assembly are properly affixed in their place.
19. Exercise caution whenever operating as a leaf blower. Do not allow discharge to be pointed in the direction of persons.
20. No one should operate this unit while intoxicated or while taking medication that impairs the senses or reactions.

CONTENTS OF HARDWARE PACK

(Hardware pack may contain extra items which are not used on your unit. Quantities of parts and part numbers are shown in parentheses.)

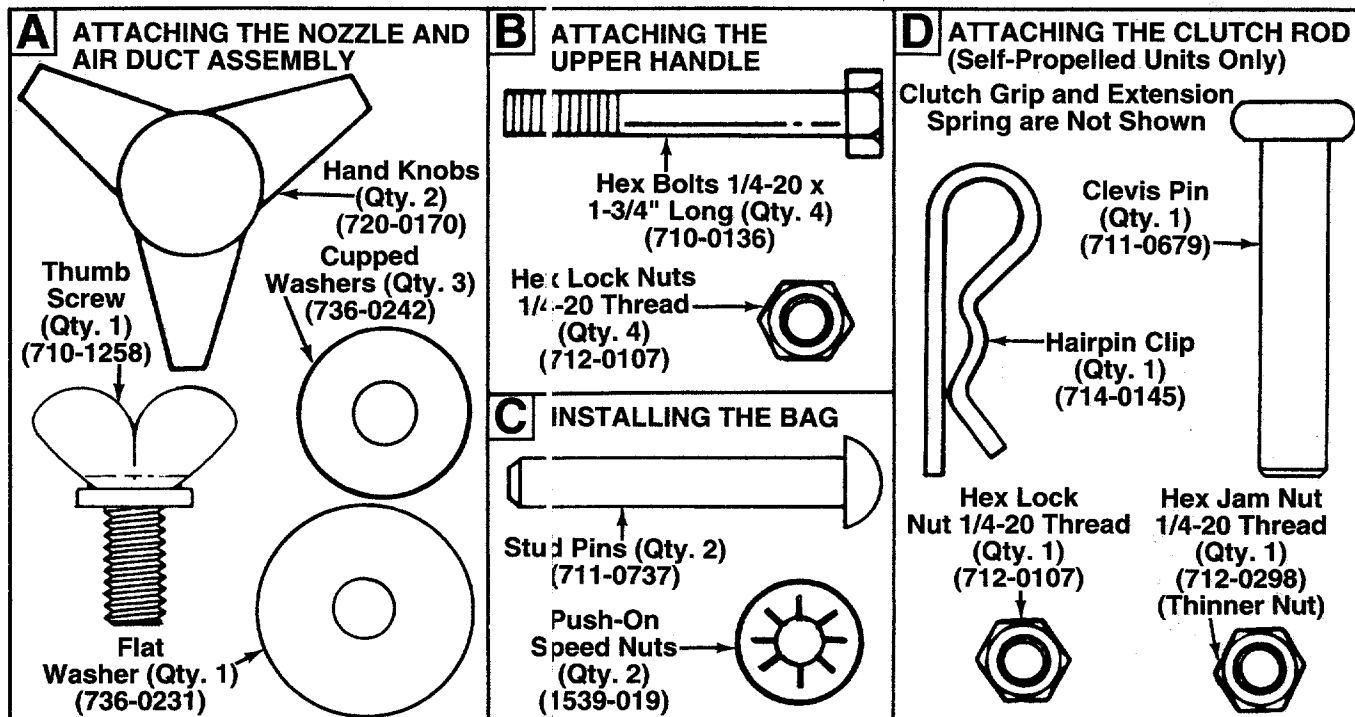

FIGURE 1.



ASSEMBLY INSTRUCTIONS

IMPORTANT: This unit is shipped **WITHOUT GASOLINE or OIL.** After assembly, service engine with gasoline and oil as instructed in the separate engine manual packed with your unit.

NOTE: Reference to right or left hand side of the vacuum is observed from behind the unit in the operating position.

UNPACKING

Remove the vacuum, loose parts, hardware pack and literature from the carton. Make certain all parts and literature have been removed before the carton is discarded.

LOOSE PARTS IN CARTON

← (See Figure 2)

- (1) Nozzle
- (1) Upper Handle
- (1) Air Duct Assembly
- (1) Clutch Rod (Self-Propelled Models Only)
- (1) Directional Discharge Assembly
- (1) Impeller Guard
- (1) Bag

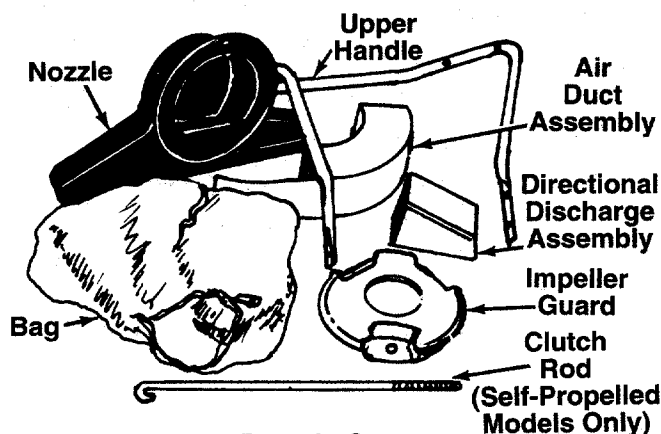

FIGURE 2.—Loose Parts in Carton

TOW BAR KIT

Standard for push models, optional for self-propelled models.

← (See Figure 3)

- A (2) Hex Bolts 5/16-18 x 1" Long
- B (4) Shoulder Spacers
- C (2) Hex Nut 5/16-18 Thread
- D (1) Truss Machine Screw 1/4-20 x 3/4" Long
- E (1) Lock Washer 1/4" I.D.
- F (1) Hex Nut 1/4-20 Thread
- G (1) Shoulder Bolt
- H (2) Cupped Washers 3/8" I.D.
- I (1) Hex Jam Lock Nut 3/8-16 Thread
- (2) Tow Bar Halves (Not Shown)

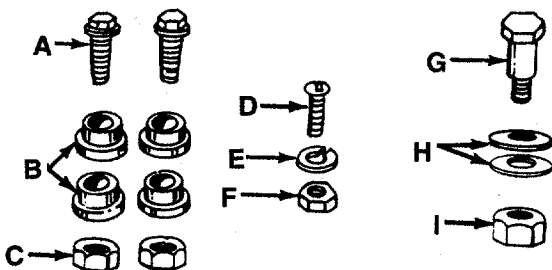

FIGURE 3.—Optional Tow Bar Kit

ATTACHING THE NOZZLE (Hardware A)

Place nozzle in position on front of housing so that it rests in flanges. Secure with one hand knob and cupped washer (cupped side of washer against the nozzle). See figure 4.

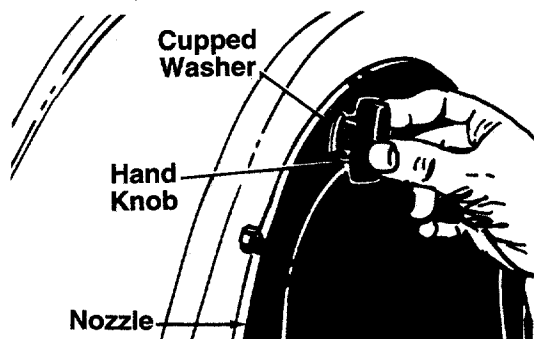

FIGURE 4.

ATTACHING THE UPPER HANDLE (Hardware B)

Place the upper handle in position over lower handle. Fasten with four hex bolts and lock nuts provided. ← See figure 5. Two 7/16" wrenches are required.

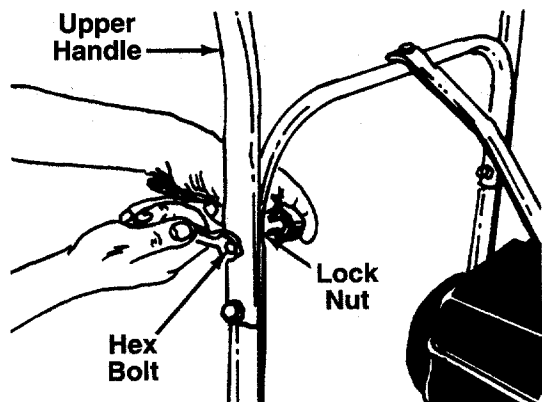

FIGURE 5.

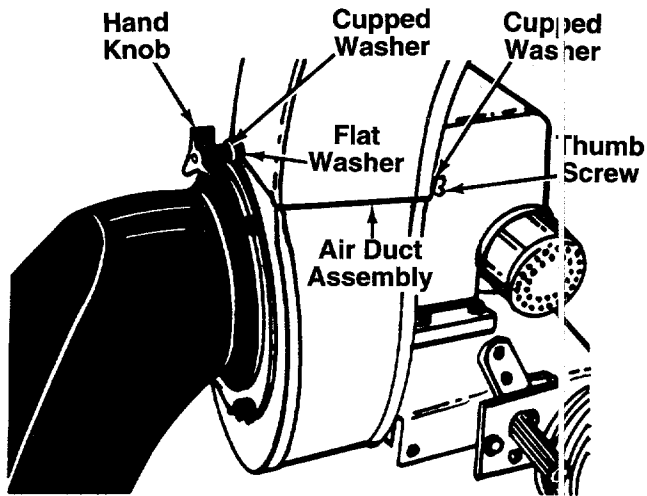

FIGURE 6.

ATTACHING THE AIR DUCT ASSEMBLY (Hardware A)

Place air duct assembly over opening on top of housing. Secure front of air duct assembly with one flat washer, cupped washer (cupped side of washer against flat washer) and a hand knob. Secure back (close to engine) with one cupped washer (cupped side against air duct assembly) and thumb screw. See ← figure 6.

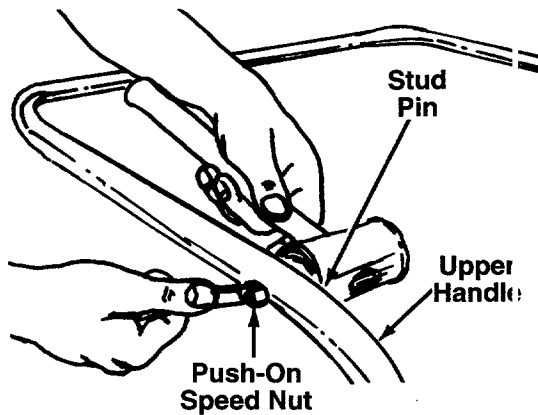

FIGURE 7.

INSTALLING THE BAG (Hardware C)

1. Place the stud pins in holes in upper handle (head of pins go to the inside of handle). Secure pins with push-on speed nuts by holding speed nut with box wrench and tapping pin with hammer. See figure 7. ←

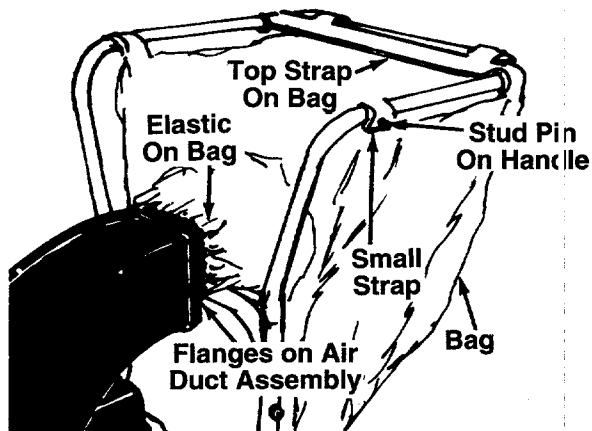

FIGURE 8.

2. Assemble the bag by slipping the top straps on bag over upper handle. Hook two small straps over stud pins on handle. Slip elastic opening of bag over air duct assembly. Be certain elastic on bag is placed over the flanges on air duct assembly. See figure 8. ←

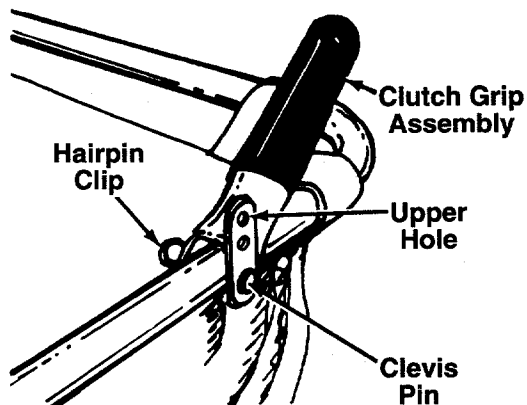

FIGURE 9.

ATTACHING THE CLUTCH ROD (Hardware D) (Self-Propelled Models Only)

1. Assemble the clutch grip to the left hand side of upper handle. Secure in place with clevis pin and hairpin clip. See figure 9. Head of clevis pin should be to the outside of handle.

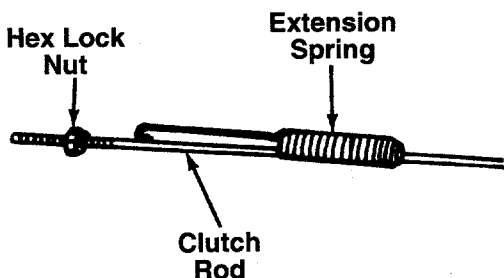

FIGURE 10.

2. Slide the extension spring onto clutch rod as shown in figure 10. Thread hex lock nut onto clutch rod approximately 2-1/2 inches.

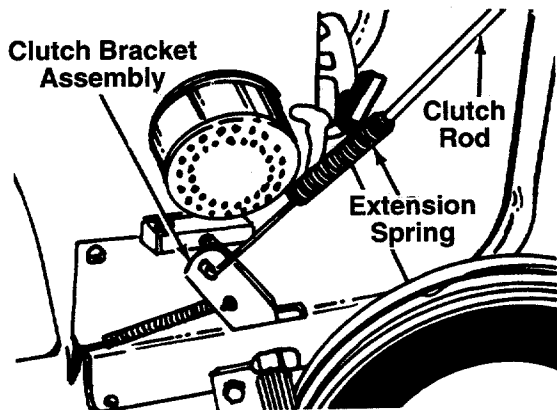

FIGURE 11.

3. Hook top (hooked end) of clutch rod into upper hole on clutch grip. See figure 9. Hook spring into clutch bracket assembly. See figure 11. Adjust nut on the clutch rod so that when the clutch grip is all the way up, there is no slack in the spring.



4. Thread hex jam nut (thinner nut) onto clutch rod, and lock it against the lock nut.

CONVERTING VACUUM TO A LEAF BLOWER



WARNING: Be sure to stop engine and disconnect spark plug wire.

1. Remove the bag. Remove the air duct assembly by removing the hand knob, cupped washer and flat washer from the front of the air duct assembly, and the thumb screw and cupped washer from behind the air duct assembly. Refer to figure 6.

2. Remove the nozzle by removing one hand knob and cupped washer. Refer to figure 4.

3. Remove the hand knob and cupped washer which hold the housing to engine brace. See figure 12.

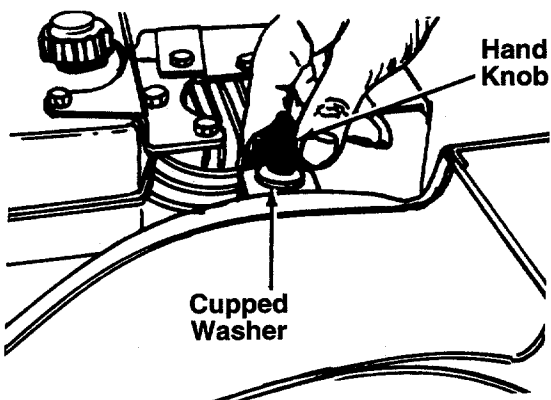

FIGURE 12.

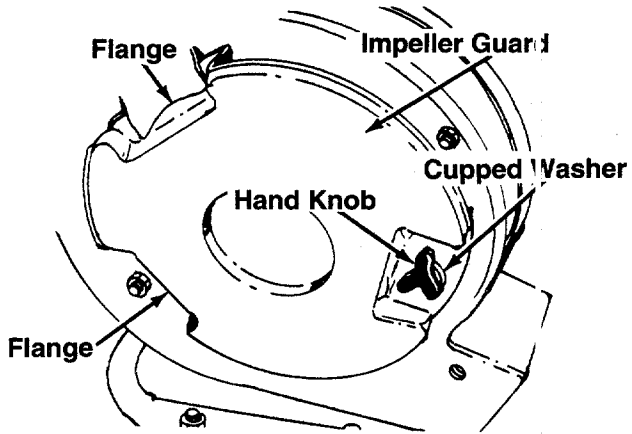

FIGURE 13.

4. Lift up and out on the housing and rotate it 105° clockwise. Chute opening should be to the right hand side when viewed from the front of unit. See figure 13.
5. Place the impeller guard into flanges on front of housing. Line up hole in guard with hole on housing. Secure with one hand knob and cupped washer (cupped side of washer against the impeller guard). See figure 13.

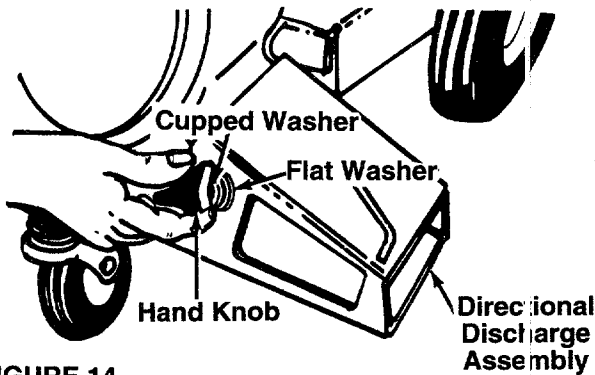

FIGURE 14.

6. Place the directional discharge assembly over chute opening. Secure with one hand knob, cupped washer and flat washer, and the thumb screw and cupped washer. The cupped side of washer goes against the flat washer. See figure 14.

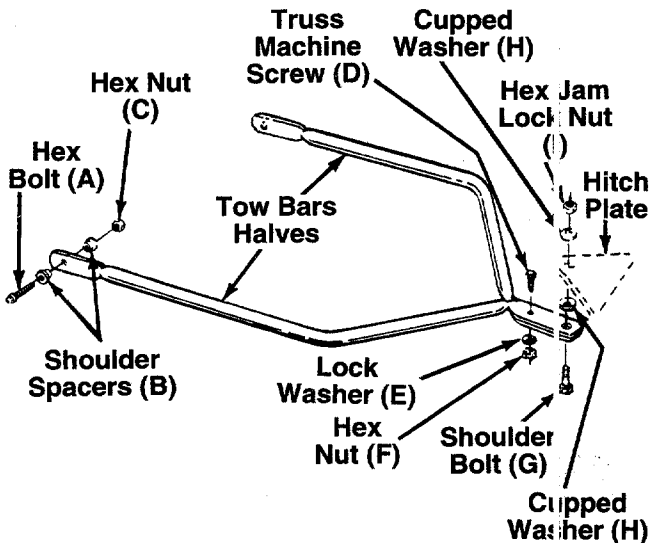

FIGURE 15.—Optional Tow Bar

INSTALLATION OF OPTIONAL TOW BAR

1. Remove the self-tapping screws on each side of frame. Refer to illustration on page 10, reference number 42.
2. Place one bar half in position on frame of vacuum. Place one shoulder spacer (B) between frame and tow bar. Next, place shoulder spacer (B) and hex bolt (A) through tow bar and frame. Secure with hex nut (C). See figure 15. Repeat on other side.
3. Secure the two tow bar ends together with truss machine screw (D), lock washer (E) and hex nut (F). See figure 15.

To attach the tow bar to a hitch, place the shoulder bolt (G) up through the tow bar. Place one cupped washer (H) on the shoulder bolt, then the hitch plate and the other cupped washer. Cupped side of the washers must be against the hitch plate. Secure with hex jam lock nut (I). See figure 15.

OPERATION

BEFORE STARTING ENGINE

Service engine with gas and oil. See engine manual packed with vacuum for complete instructions for care and maintenance of engine. Read directions carefully.



WARNING: Revolving blades -- keep hands away from all openings.

TO START ENGINE

After the engine has been properly fueled and oiled (refer to engine operating and maintenance instructions), start engine as follows.

1. Move choke lever on engine to CHOKE position. (A warm engine may not require choking.)
2. Move throttle control lever on engine to FAST position.

3. Grasp starter handle and pull rope out slowly until engine reaches start of compression cycle (rope will pull slightly harder at this point). Let the rope rewind slowly.
4. Pull rope with a rapid, continuous, full arm stroke. Keep a firm grip on starter handle. Let rope rewind slowly. Do not let starter handle snap back against starter.
5. Repeat instructions 3 and 4 until engine fires. When engine starts, move choke control gradually to RUN position.
6. **Self-Propelled Models Only**—To engage the drive mechanism, squeeze the clutch grip against the upper handle. Release the clutch grip to stop the forward motion.

TO STOP ENGINE

1. To stop engine, move throttle control lever to OFF position.
2. Disconnect spark plug wire and ground to prevent accidental starting while equipment is unattended.

IMPORTANT: The vacuum bag may have an air escape located on the upper right hand side. See

figure 16. The air escape can be opened if the vacuum is operated in wet, sandy or muddy conditions.

The bag may be emptied using the large zipper as shown in figure 16. **Be certain the zipper is closed when operating the unit.**

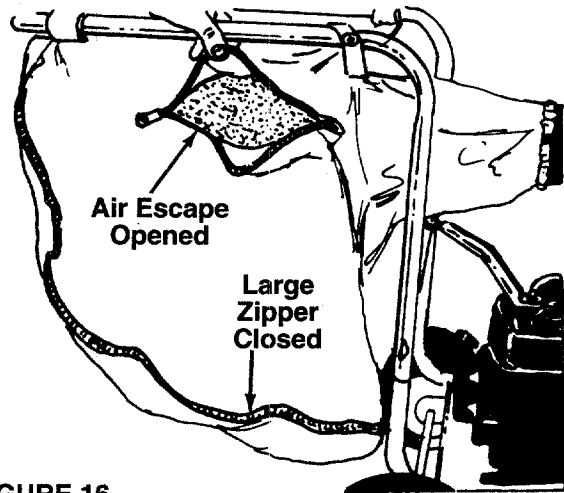

FIGURE 16.

ADJUSTMENTS



WARNING: Do not at any time make any adjustment to the unit without first stopping engine and disconnecting spark plug wire.

HEIGHT ADJUSTMENT

The height adjustment crank is located on the right hand side of the vacuum. See figure 17. Turn the crank clockwise to raise the nozzle. Turn the crank counterclockwise to lower.

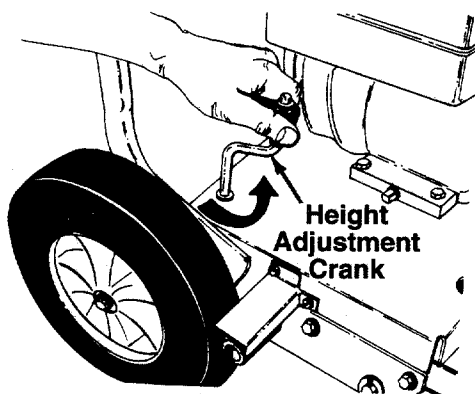

FIGURE 17.

CARBURETOR ADJUSTMENT



WARNING: If any adjustments are made to the engine while the engine is running (e.g. carburetor), keep clear of all moving parts. Be careful of heated surfaces and muffler.

Minor carburetor adjustment may be required to compensate for differences in fuel, temperature, altitude or load.

NOTE: A dirty air cleaner will cause engine to run rough. Be certain air cleaner is clean and attached to the carburetor before adjusting carburetor.

Do not make unnecessary adjustments. Factory settings are satisfactory for most applications and conditions. If adjustment is needed, refer to the separate engine manual packed with your vacuum.

CLUTCH ROD ADJUSTMENT (Self-Propelled Models Only)

To adjust the clutch rod, refer to step numbers 3 and 4 under "Attaching the Clutch Rod" in Assembly Instructions.

MAINTENANCE



WARNING: Always stop engine and disconnect spark plug wire before cleaning, lubricating or performing any repairs or maintenance.

LUBRICATION

Wheels—Rear wheels are provided with light oil bearings. Place a few drops of SAE 30 oil on each bearing once a season.

Gear Box (Self-Propelled Models Only)—The gear box is lubricated with 3 ounces of High Temp. (450° F.) grease. Order part number 737-0223. Periodically check lubricant level by removing the two self-tapping screws on the gear box cover and lifting off the cover. Do not change grease; simply add if necessary.

ENGINE

Refer to the separate engine manual for engine maintenance instructions.

Maintain engine oil as instructed in the separate engine manual packed with your unit. Read and follow instructions carefully.

Service air cleaner every 25 hours under normal conditions. Clean every few hours under extremely dusty conditions. Poor engine performance and flooding usually indicates that the air cleaner should be serviced. To service the air cleaner, refer to the separate engine manual packed with your unit.

The spark plug should be cleaned and the gap reset once a season. Spark plug replacement is recommended at the start of each season; check engine manual for correct plug type and gap specifications.

Clean the engine regularly with a cloth or brush. Keep the cooling system (blower housing area) clean to permit proper air circulation which is essential to engine performance and life. Be certain to remove all dirt and combustible debris from muffler area.

BELT REPLACEMENT (Self-Propelled Models Only)

1. Remove the nozzle or impeller guard from front of blower housing.
2. Remove hex bolt and lock washer from center of impeller. See figure 18. A 9/16" socket wrench with extension is needed.

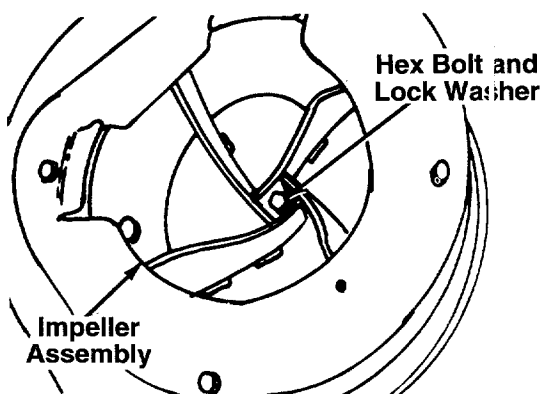

FIGURE 18.

3. Remove hand knob and cupped washer from top of housing.
4. Remove two self-tapping screws which hold the belt guard. See figure 19. A 3/8" wrench is required. Lift off belt guard.

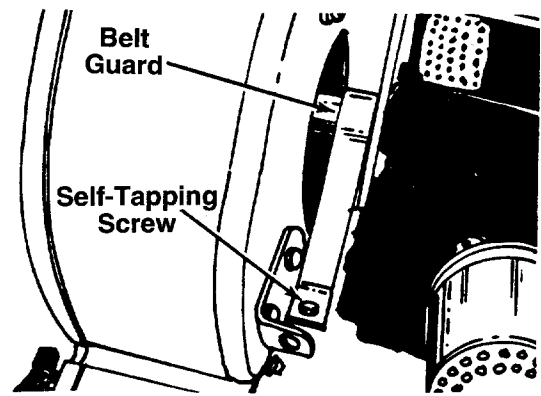

FIGURE 19.

5. Slide belt off the impeller pulley. Slide housing and impeller off engine crankshaft. Be careful not to lose square key. See figure 20.

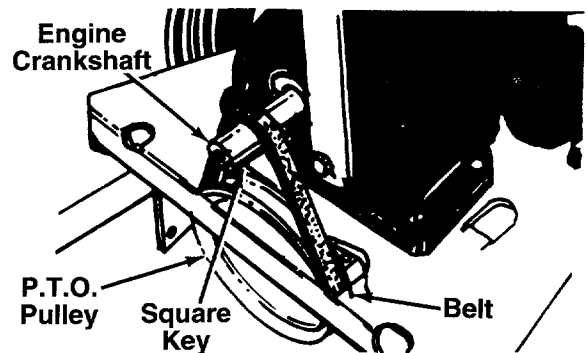

FIGURE 20.

6. Slide impeller and blower housing assemblies off crankshaft.
7. Remove belt from P.T.O. pulley and install new belt. See figure 20.

NOTE: When reassembling the new belt, the aid of another person will be helpful.

8. Turn the crankshaft until the keyway on shaft is directly on top. While holding housing assembly and impeller assembly, line up the keyway on the pulley with the key on the crankshaft, and slide housing and impeller assemblies onto crankshaft.
9. Secure impeller to crankshaft with hex bolt and lock washer, removed in step 2. Tighten securely.
10. Slip belt over impeller pulley. Reassemble the belt guard.
11. Secure blower housing with hand knob and washer.
12. Reassemble the nozzle or impeller guard.

OFF-SEASON STORAGE

The following steps should be taken to prepare your vacuum for storage.

1. Clean and lubricate the vacuum thoroughly as described in the lubrication instructions.
2. Refer to engine manual for correct engine storage instructions.
3. If storing in an unventilated or metal storage shed, coat metal parts with a light oil or silicone to prevent rust.
4. Store in a dry, clean area. Do not store next to corrosive materials, such as fertilizer.

OPTIONAL EQUIPMENT

Hose Attachment Kit Model 290-204-000 is available as optional equipment. See figure 21.

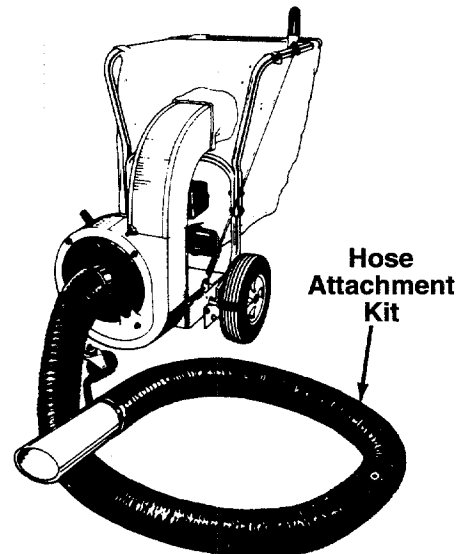

FIGURE 21.

TROUBLE SHOOTING

PROBLEM	POSSIBLE CAUSE(S)	CORRECTIVE ACTION
Engine fails to start	<ol style="list-style-type: none"> 1. Fuel tank empty, or stale fuel. 2. Spark plug wire disconnected. 3. Faulty spark plug. 	<ol style="list-style-type: none"> 1. Fill tank with clean, fresh fuel. 2. Connect wire to spark plug. 3. Clean, adjust gap or replace.
Loss of power; operation erratic	<ol style="list-style-type: none"> 1. Spark plug wire loose. 2. Unit running on CHOKE. 3. Blocked fuel line (if so equipped) or stale fuel. 4. Water or dirt in fuel system. 5. Carburetor out of adjustment. 6. Dirty air cleaner. 	<ol style="list-style-type: none"> 1. Connect and tighten spark plug wire. 2. Move choke lever to OFF position. 3. Clean fuel line; fill tank with clean fresh gasoline. 4. Disconnect fuel line at carburetor to drain fuel tank. Refill with fresh fuel. 5. Adjust carburetor.† 6. Service air cleaner.†
Engine overheats	<ol style="list-style-type: none"> 1. Carburetor not adjusted properly. 2. Engine oil level low. 	<ol style="list-style-type: none"> 1. Adjust carburetor.† 2. Fill crankcase with proper oil.
Too much vibration	Loose parts or damaged crankshaft.	Stop engine immediately and disconnect spark plug wire. Tighten all bolts and nuts. Make all necessary repairs. If vibration continues, have unit serviced by an authorized service dealer.
Unit does not discharge	<ol style="list-style-type: none"> 1. Directional discharge or nozzle clogged. 2. Foreign object or dirt lodged in air vane plate assembly. 3. Vacuum bag is full. 4. Belt worn and/or stretched. 	<ol style="list-style-type: none"> 1. Stop engine immediately and disconnect spark plug wire. Clean directional discharge or nozzle. 2. Stop engine immediately and disconnect spark plug wire. Remove lodged object or dirt. 3. Empty bag. 4. Replace belt. See maintenance section of this manual.

†Refer to the engine manual packed with your unit.

NOTE: For repairs beyond the minor adjustments listed above, please contact your nearest authorized service dealer.





For Replacement Parts, Contact:
SERVICE DEPARTMENT • P.O. BOX 368022 • CLEVELAND, OHIO 44136-9722