

# INSTALLATION MANUAL

CE

MAP  
450D

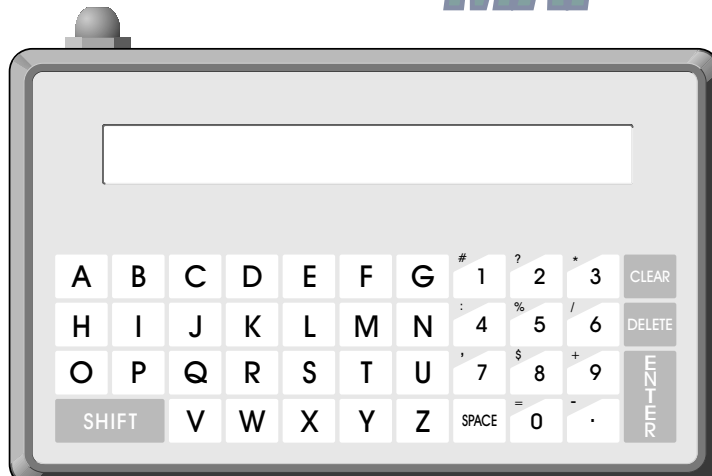

*Secure online ordering 24/7/365 from*



**International Headquarters:**

707 Dayton Rd. - P.O. Box 1040 - Ottawa, IL 61350 USA

[www.bb-elec.com](http://www.bb-elec.com)

Phone: 815-433-5100  
Fax: 815-433-5104

[orders@bb-elec.com](mailto:orders@bb-elec.com)  
[support@bb-elec.com](mailto:support@bb-elec.com)

**European Headquarters:**

Westlink Commercial Park Oranmore, Co. Galway, Ireland

[www.bb-europe.com](http://www.bb-europe.com)

Phone: +353 91 792444  
Fax: +353 91 792445

[orders@bb-europe.com](mailto:orders@bb-europe.com)  
[support@bb-europe.com](mailto:support@bb-europe.com)

## COPYRIGHT NOTICE

This manual is a publication of Maple Systems, Inc., and is provided for use by its customers only. The contents of the manual are copyrighted by Maple Systems, Inc.; reproduction in whole or in part, for use other than in support of Maple Systems equipment, is prohibited without the specific written permission of Maple Systems.

## WARRANTY

Maple Systems warrants each product to be free from electrical and mechanical defects in materials and workmanship for a period of one year from the date of shipment. This warranty does not apply to defects in the Products caused by abuse, misuse, accident, casualty, alteration, negligence, repair not authorized by Maple Systems, use on current or voltages other than specified by Maple Systems, or application or installation not in accordance with published instruction manuals. This warranty is in lieu of any other warranty either expressed or implied.

Maple Systems' liability is limited to the repair or replacement of the Product only, and not costs of installation, removal, or damage to user's property or other liabilities. If Maple Systems is unable to repair or replace a nonconforming Product, it may offer a refund of the amount paid to Maple Systems for such Product in full satisfaction of its warranty obligation. Maximum liability of Maple Systems is the cost of the Product.

Information furnished by Maple Systems, Inc., is believed to be accurate and reliable. However, no responsibility is assumed by Maple Systems for the use of this information nor for any infringements of patents or other rights of third parties which may result from its use. No license is granted by implication, or otherwise, under any patent or patent rights of Maple Systems, Inc. Maple Systems retains the right to revise or change its products and documentation at any time without notice.

## IF SERVICE IS REQUIRED

Package the unit in its original packaging container or, if unavailable, any suitable rigid container. If a substitute container is used, surround the unit with shock absorbing material; damage in shipment is not covered by the warranty. Include a letter with the unit describing the difficulty and designating a contact person. Send to the following address: Maple Systems, Inc., 808 134th Street SW, Suite 120, Everett, WA 98204.

Only Products that have been issued a Return Material Authorization (RMA) number from Maple Systems may be returned. All RMAs must be accompanied with a written purchase order for tracking purposes or, in the case of out-of-warranty repairs, for repair charges on a time and material basis.

All returns will be tested to verify customer claims of noncompliance with the product warranty. Improper return packaging which makes verification impossible will void the warranty. Products passing the tests will be returned "AS IS" to the customer.

If noncompliance is verified and is not due to customer abuse or the other exceptions described with product warranty, Maple Systems will, at its option, repair or replace the Product returned to it, freight prepaid, which fail to comply with the foregoing warranty, provided Maple Systems is notified of such noncompliance within the one-year warranty period.

## APPLICATIONS ASSISTANCE

This manual is designed to provide the necessary information for trouble-free installation and operation of your new Operator Interface Terminal (OIT). However, if you need assistance, please call Maple Systems at 425-745-3229 or visit our web site at [www.maple-systems.com](http://www.maple-systems.com).

## Read Me First!

Your new Maple Systems OIT comes from the factory configured with the default communication settings: 9600 baud, no parity, 8 data bits, 1 stop bit, no handshaking, no turn-around delay, 90 viewing angle, interactive mode, CR line terminator, underline cursor, 1 space tab width, local echo enabled, local setup enabled, local keyboard enabled, key click enabled, block echo enabled. You can change these settings through the MAP450D's local setup menus or by using the STEPware-100 configuration software (sold separately). If you want to store messages in the MAP450D, you must use STEPware-100.

To ensure that the OIT meets CE compliance, it is necessary to follow all installation procedures described in this manual.

## Introduction

Thank you for purchasing a Maple Systems MAP450D. You have selected a rugged, reliable, and powerful operator interface for your application. This booklet describes the steps necessary to ensure trouble-free OIT system operation. **Please read this booklet carefully!!**

## Static Awareness



### CAUTION

It is best NOT to remove the rear cover on the OIT except when accessing the terminal block pins or panel mounting the OIT. When the rear cover is removed, the circuitry inside is exposed to possible damage by electrostatic discharge during handling. Minimize the possibility of electrostatic discharge by:

- Discharging personal static by grounding yourself prior to handling the OIT.
- Handling the OIT at static-free, grounded work stations.
- Connecting the chassis of the OIT to a clean ground.
- Placing the OIT into an anti-static bag during transport.

## Unpacking the Unit

Carefully unpack the OIT. Please read any instructions or cautions that appear on the shipping container. Check all material in the container against the enclosed packing list. Maple Systems, Inc., will not accept responsibility for shortages against the packing list unless notified within 30 days. The equipment and its accessories were inspected and tested by Maple Systems before shipment; all of the equipment should be in good working order. Examine the equipment carefully; if any shipping damage is evident, notify the carrier immediately. You are responsible for claim negotiations with the carrier. Save the shipping container and packing material in case the equipment needs to be stored, returned to Maple Systems, or transported for any reason.

# TABLE OF CONTENTS

1. Control Panel Design Guidelines .....	5
1.1. Control Panel Grounding .....	5
1.2. Power Supply Selection .....	5
1.3. OIT Cable Routing .....	6
1.4. Other Steps to Improve Noise Immunity .....	6
2. Connecting the MAP450D to a Host Controller .....	7
2.1. RS-232 (Interactive & Block modes) .....	9
2.2. RS-422/485 (Interactive & Block modes) .....	9
2.3. RS-422/485 (Network mode) .....	10
2.4. Set Jumper for 3-Wire RS-422/485 .....	13
3. Mounting the MAP450D .....	14
3.1. Panel Mount .....	14
3.2. Pedestal/Pendent Mount .....	15
3.3. Benchtop Mount .....	16
4. Configuring the MAP450D .....	17
4.1. Connecting the MAP450D to a PC .....	17
Appendix A: OIT Hardware Specifications .....	18
Appendix B: Differences Between MAP450D and MAP450B .....	20

# 1. Control Panel Design Guidelines

Pay careful attention to the placement of system components and associated cable routing. These items can significantly enhance the performance and integrity of your control application.

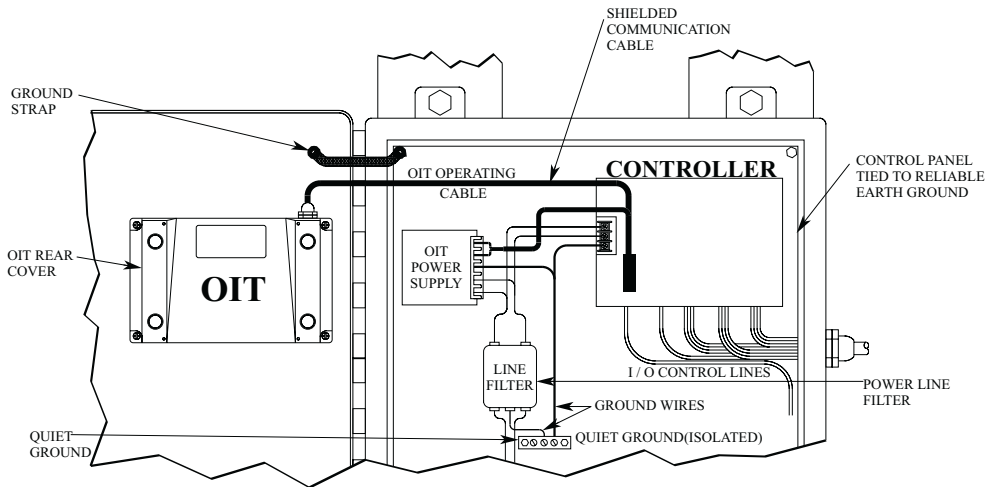

Figure 1 Control Panel Example

## 1.1. Control Panel Grounding

- The control panel should be connected to a good, high-integrity earth ground both for safety considerations and shielding purposes. This must be a reliable earth ground with a low-resistance path. The ideal earth ground would be a copper grounding rod located close to the OIT and the control panel.
- Hinged doors on control panels do not provide a long term electrical connection to the rest of the enclosure. Corrosion develops over time and prevents good electrical contact. For this reason, a separate wire braid should be installed from the hinged control panel to the rest of the enclosure.

## 1.2. Power Supply Selection

- The power supply used to power the OIT should have an output between +12 and +30 VDC. The voltage should measure between +12 and +30V at the OIT between Pins 2 and 3 of the OIT terminal block. A 24 VDC, 0.5 amp linear power supply dedicated to the OIT is recommended.
- The power leads on the operating cable for the OIT should be 18AWG 2-conductor wire with a shield wire and protective shield foil. The shield of the OIT operating cable must be connected to earth ground at both ends of the cable. Please refer to Section 2.

- A power line filter installed at the AC input to the OIT power supply is highly recommended as a safeguard against conducted RF noise, which is often present on factory power lines. The wires connecting the output of the power line filter to the power supply should be kept as short as possible to minimize any additional noise pickup. The case of the power line filter should be connected to a quiet earth ground. The power line filter should have a current rating of at least three amps with common mode and differential mode attenuation.

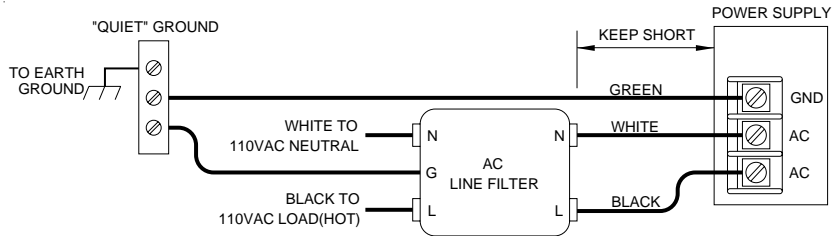

**Figure 2 Power Line Filter Connection**

- The power supply that provides power to the OIT should not be used to power switching relays or solenoids unless noise filter caps are connected to each relay.

### 1.3. OIT Cable Routing

- Always route the OIT operating cable away from any AC voltage or host controller wires.
- Never bundle the OIT cables together with 120 VAC power wires or with relay wiring.
- Try to keep at least 8 inches (20 cm) of separation between the OIT cables and other power wiring. If voltages greater than 120 VAC are used in the system, greater separation is required.
- If the OIT cables must come near AC wiring, make sure they cross at 90 degrees.
- Running AC power wires in a separate grounded conduit is the preferred method for electrical noise reduction.
- Keep the lengths of the OIT cables as short as possible. Do not coil excess cable and place it next to AC powered equipment.

### 1.4. Other Steps to Improve Noise Immunity

- Always install the OIT's rear cover. This provides a shield against electrical noise which can be generated in the control panel by relays, motors, power lines, and/or high frequency equipment. Ensure that all rear cover mounting screws are properly secured.
- Any equipment used in the enclosure that operates at high frequency or high current levels can be covered with a grounded metal shield.

## 2. Connecting the MAP450D to a Host Controller

It is necessary to follow all installation procedures described in this chapter for electrical noise immunity and CE compliance.

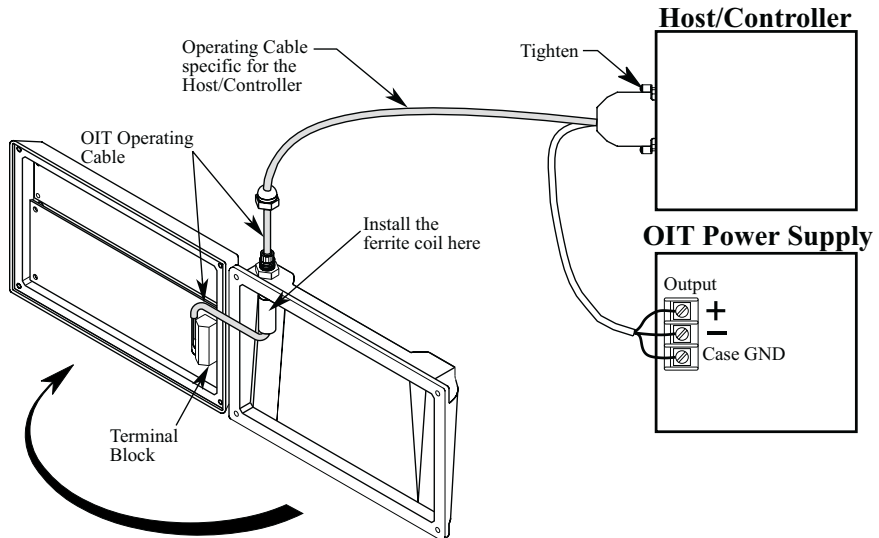
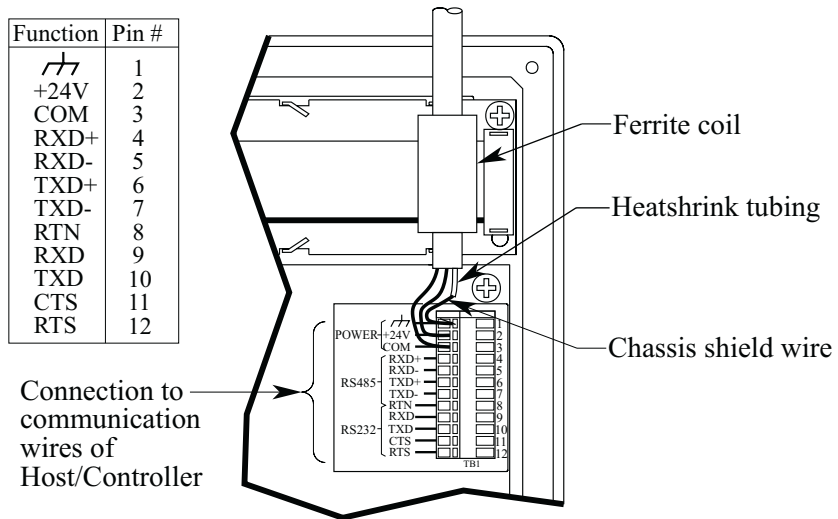

Figure 3 MAP450D Cable Connections

### STEPS

1. Remove the four screws from the back of the OIT enclosure and open the two halves.
2. A strain relief is provided for wiring access and sealing. The cable must be inserted through the strain relief and into the cover.
3. Remove the black heatshrink tubing from the end of the OIT operating cable.
4. Slide the ferrite coil over the OIT operating cable. This usually requires rotating the ferrite coil back and forth while simultaneously pulling on the OIT operating cable.
5. Slide the ferrite coil up against the inside wall of the OIT enclosure and pull through enough additional cable to reconnect the OIT operating cable wires.

6. Connect the OIT operating cable wires to the terminal block. Refer to sections 2.1 through 2.3 and Figure 4.



**Figure 4 Terminal Block Pinout Connection**

7. Pull out any slack from the OIT operating cable.
8. Rotate the rear of the OIT enclosure back into position while gently pulling out the new slack generated in the cable as you proceed.

**CAUTION:** Due to the large size of the ferrite coil, it must be positioned very carefully. Make sure that when the OIT enclosure halves are brought together, the ferrite coil is positioned so there is no internal interference. The ferrite coil must be positioned up against the inside wall of the OIT enclosure with the protruding OIT operating cable kept short.

9. Tighten the cable strain relief nut.
10. Re-install the four screws into the back of the OIT enclosure
11. Route the operating cable to the host controller and connect.
12. Route the power pigtail to the OIT power supply.
13. Install the wires into the power supply as follows:

RED	+output
BLACK	-output
SHIELD	case ground.



## 2.1. RS-232 (Interactive & Block modes)

Interactive and Block modes support the 3-wire RS-232 configuration with TXD, RXD and signal common. The cable requires an overall shield to protect against electrical noise. Xon and Xoff can be used for communication handshaking.

3-Wire RS-232	
Host Controller	MAP450D Terminal Block
TXD	Pin 9 RXD
RXD	Pin 10 TXD
Signal Ground	Pin 8 Return

## 2.2. RS-422/485 (Interactive & Block modes)

Interactive and Block modes support the 3-wire and 5-wire RS-422/485 configurations. The 3-wire configuration has both transmit and receive on the same pair of wires plus a signal common. The 5-wire configuration has differential signal pairs for transmit and receive plus a signal common. In both configurations the signal pairs must be twisted and surrounded by an overall shield.

**NOTE:** *When using 3-wire RS-422/485, Jumper JP4 must be in position “B”. Refer to section 2.4 for instructions.*

3-Wire RS-422/485	
Host Controller	MAP450D Terminal Block
TXD+ & RXD+	Pins 4 & 6 RXD+ & TXD+
TXD- & RXD-	Pins 5 & 7 RXD- & TXD-
Signal Ground	Pin 8 Return

5-Wire RS-422/485	
Host Controller	MAP450D Terminal Block
TXD+	Pin 4 RXD+
TXD-	Pin 5 RXD-
RXD+	Pin 6 TXD+
RXD-	Pin 7 TXD-
Signal Ground	Pin 8 Return

## 2.3. RS-422/485 (Network mode)

Network mode supports the 3-wire and 5-wire RS-422/485 configurations. The 3-wire configuration has both transmit and receive on the same pair of wires plus a signal common. The 5-wire configuration has differential signal pairs for transmit and receive plus a signal common. In both configurations the signal pairs must be twisted and surrounded by an overall shield.

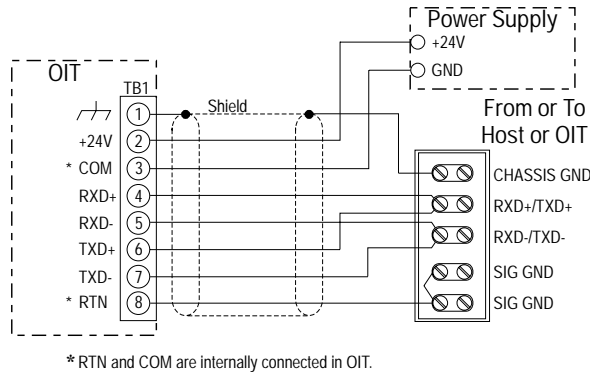

**Figure 5 3-Wire RS-422/485 (Network mode)**

**NOTE:** When using 3-wire RS-422/485, Jumper JP4 must be in position “B”. Refer to section 2.4 for instructions.

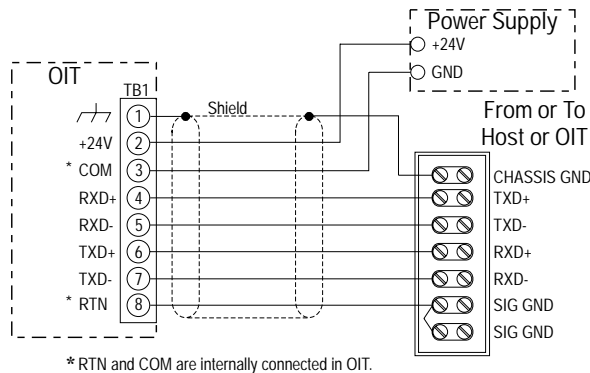

**Figure 6 5-Wire RS-422/485 (Network mode)**

5-wire RS-422/485 supports full-duplex communications; which means that the host controller can transmit data to the OITs and receive data from the OITs at the same time. 3-wire RS-422/485 only supports half-duplex communications; which means that the host controller cannot transmit and receive data at the same time. Although 3-wire RS-422/485 installations may be less costly than 5-wire installations, the increased complexity in programming the host controller for 3-wire RS-422/485 may increase development time.

There are several different forms of communications networks. Maple Systems' OITs utilize the multidrop format. The host controller, located at one of the network ends, is connected to the OITs via a continuous com-link. Each OIT is connected to the network by locally tapping into the com-link with short stub cables. The end of the com-link must be properly terminated to reduce noise pickup and interference. The total length of the com-link, from the host controller to the network cable terminator, can be up to 4,000 feet.

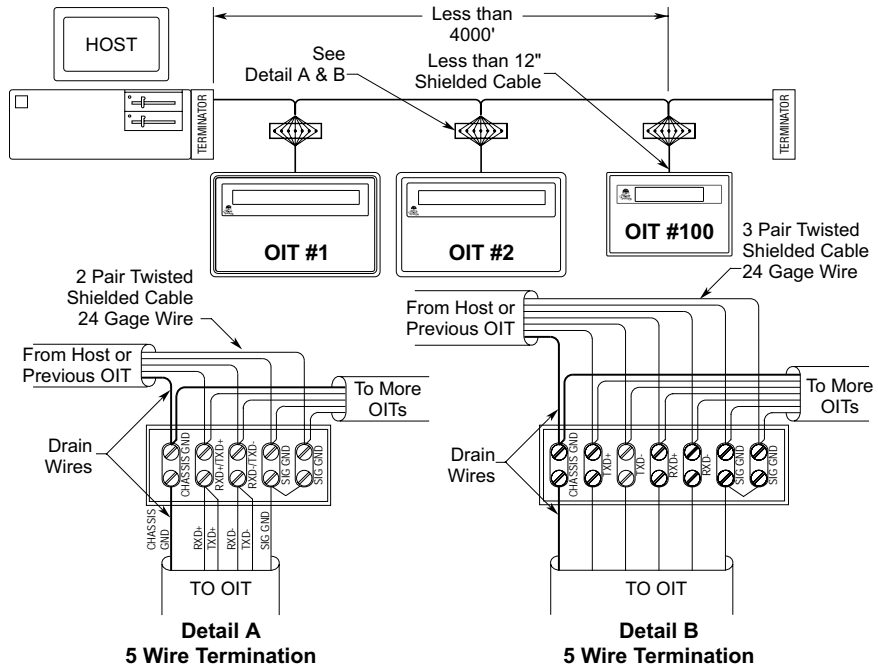

If you decide to use 3-wire RS-422/485, the following limitations apply:

- The host controller must disable or tri-state its RS-485 transmitter when it is not sending data to the OITs on the network. To simplify programming, the host should disable or tri-state its RS-485 receiver whenever transmitting.
- The ability to stay logged on to a particular OIT by sending the command terminator instead of the line terminator is not available in this mode. Therefore, each command sent from the host controller should end with the appropriate line terminator.
- If the host controller sends a command that requires a response from the OIT, the host controller must wait for a response from the OIT before sending another command. Otherwise, a situation can occur in which the OIT and the host controller attempt to transmit at the same time causing unpredictable results.
- The ASCII strings sent by the OIT's function keys should not include any control characters which the other OITs on the network could misinterpret, such as the line terminator or command terminator.

## Network Termination

The com-link cable must be properly terminated to reduce the amount of interference and noise pickup from the surrounding environment. This is accomplished by using a termination circuit at both ends of the network cable. The following figure shows a typical termination circuit. The host termination is only needed if the host controller's RS-422/485 adapter does not contain any built-in terminator circuitry. The end termination must be done at the extreme end of the com-link cable.

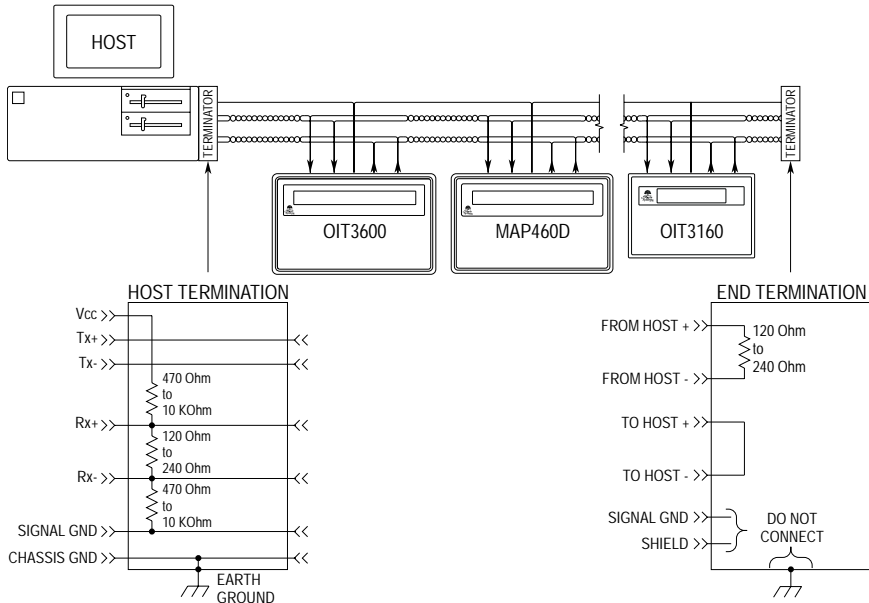

## Network Grounding

To communicate properly, serious attention must be paid to the grounding scheme of the devices connected to the com-link. Improper grounding, improper termination, and faulty shielding of the com-link are the most common causes of system failure in a multidrop network.

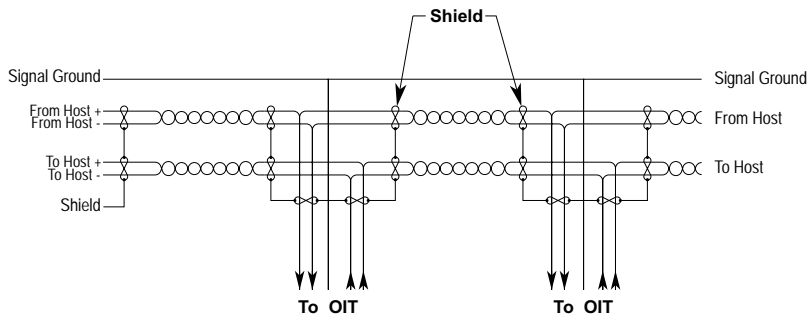

**The cable shield must not be used as the signal ground.**

It is tempting to try and reduce the cost of 5-wire cabling by using a 4-wire cable with the shield used as the signal ground. **DON'T DO IT.** The initial cost savings are always exceeded by the maintenance costs once the system is operating under field conditions. It is often necessary to completely replace the network com-link with the proper cable (5-wire plus shield) to eliminate noise problems in the system.

**The signal ground must not be connected to the chassis or earth ground.**

The chassis or earth ground is intended as a safety ground for power supplies, EMI filters, voltage spike protection circuits, 120 VAC neutral returns, and all manner of AC and DC driven devices. As a result, the chassis or earth ground can carry large voltage potentials and currents. Connecting the signal ground to chassis or earth ground can damage the devices connected to the com-link.

## 2.4. Set Jumper for 3-Wire RS-422/485

This step is required only if the OIT will be communicating with the host controller using RS-485 half-duplex 3-wire communication.

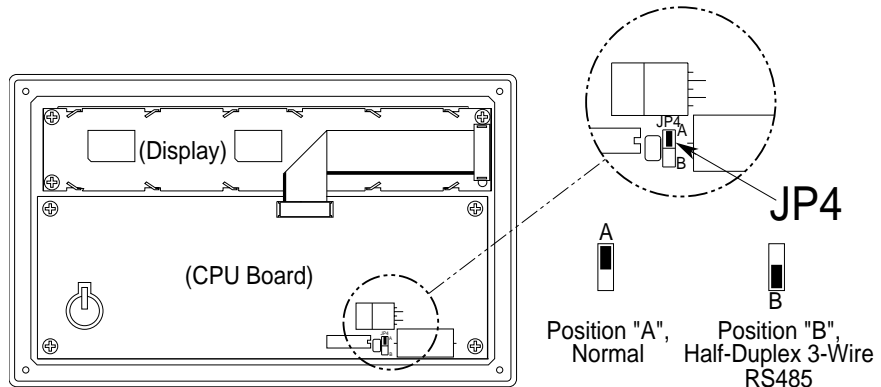

**Figure 7 MAP450D Jumper Installation**

### STEPS

1. Remove the protective cover from the rear of the unit.

**CAUTION:** *When the rear cover is removed, the circuitry inside is exposed to possible damage by electrostatic discharge. Refer to Static Awareness on page 4.*

2. Locate jumper “JP4” using Figure 7 as a guide. The jumper is installed on the upper two pins of a 3-pin header. This is called Position “A”.
3. Move the jumper to the lower two pins of the 3-pin header (Position “B”). Ensure that the jumper is pressed fully into place.
4. Replace the rear cover and the four retaining screws.

## 3. Mounting the MAP450D

### 3.1. Panel Mount

The OIT is installed in a panel by separating the front and rear covers of the OIT, and then sandwiching the panel between the two. The gasketed surface of the OIT's front cover provides the environmental seal to NEMA 4 and NEMA 12 standards. The rear cover helps shield the OIT from dust, dirt, induced electrical noise, and physical damage.

The OIT is mounted using four #6-32UNC screws sandwiching the OIT halves to panel. Screw length is equal to panel thickness plus 1/2 inch.

**NOTE:** The mounting screws must not be torqued to more than 18 pound-inches. Over-torquing can strip the threads in the front half.

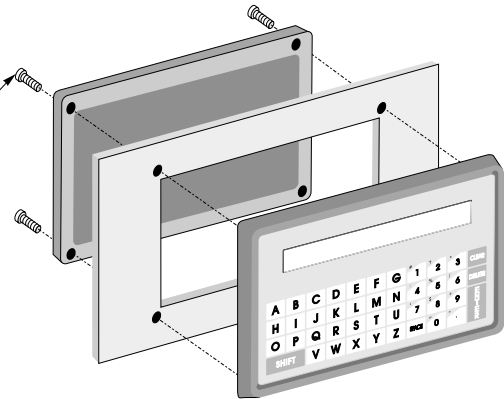

Figure 8 MAP450D Panel Mounting

Figure 9 shows the dimensions of the panel cutout required for proper panel installation. The panel cutout should be cleaned and deburred before the OIT is installed.

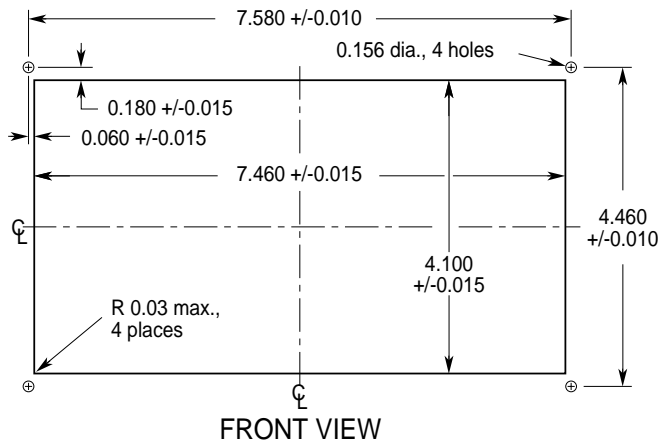
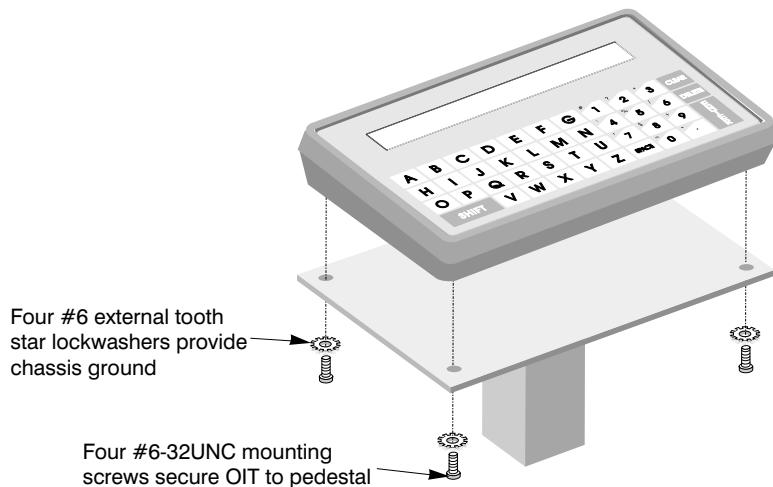

Figure 9 MAP450D Panel Cutout Dimensions

**IMPORTANT:** *When panel mounting the MAP450D, do not catch the display connector on the panel cutout. The display is exposed while panel mounting and extra care should be taken. The display can be damaged if the display cable connector, which protrudes from the panel cutout, is touching the panel when tightened. To avoid damage, place the MAP450D gently onto the panel while monitoring for this condition.*

### 3.2. Pedestal/Pendent Mount

The OIT is installed onto a pedestal/pendent by removing the four rubber feet from the rear cover of the OIT, then attaching the OIT to a mounting plate using the four pre-tapped holes in the rear cover. The OIT enclosure and cable strain relief provide the environmental seal to NEMA 4 and NEMA 12 standards.



**Figure 10 MAP450D Pedestal Mounting**

Figure 11 shows the minimum dimensions of the pedestal/pendant mounting plate. The area on the pedestal/pendant mounting plate around the mounting holes (where the heads of the screws make contact) should have any existing paint or plating removed to allow for a good chassis ground connection. The mounting screws are installed using external tooth star washers to ensure a positive ground connection.

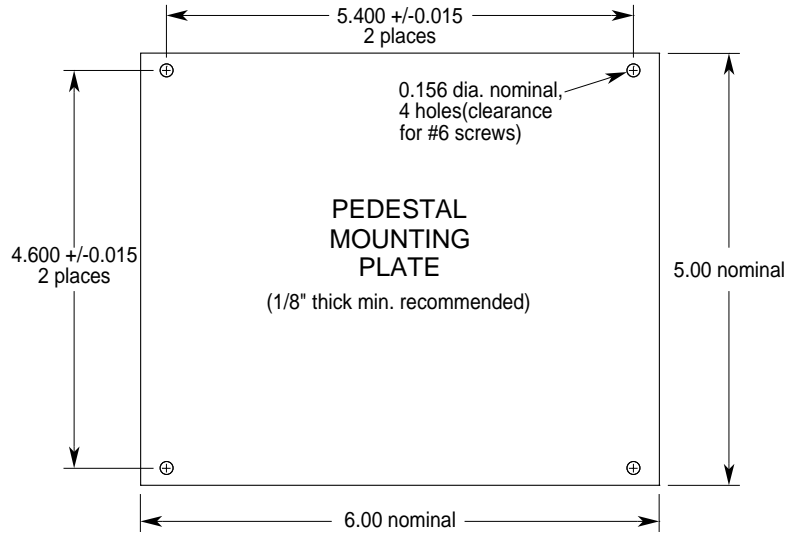

**Figure 11 Pedestal/Pendant Mounting Plate Dimensions**

The OIT is connected to the mounting plate with four #6-32UNC screws. The length of the mounting screws is equal to the plate thickness plus 1/4 inch.

**NOTE:** *The mounting screws must not be torqued to more than 18 pound-inches. Over-torquing can strip the threads in the enclosure.*

### 3.3. Benchtop Mount

The MAP450D's rear cover has two legs set at a five degree angle to give the display and keypad a sloped front while sitting on a bench. Four rubber feet are attached to the legs to prevent slippage as well as damage to the surface of the bench.

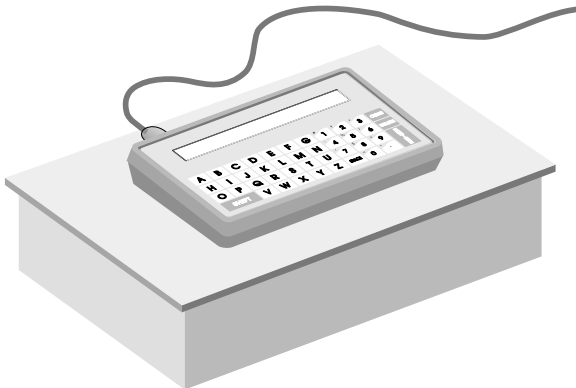

**Figure 12 MAP450D Benchtop Mounting**



## 4. Configuring the MAP450D

The MAP450D has many operating parameters that control how it communicates to the host controller. These operating parameters can be changed in three ways: from the MAP450D's keyboard when it is in Configuration mode, when the host controller sends a Configuration Control Command, or by downloading a STEPware-100 project. This chapter explains how to connect the MAP450D to a PC so you can download a project from the STEPware-100 configuration software.

### 4.1. Connecting the MAP450D to a PC

First, remove the operating cable from the terminal block pins. Next, connect an RS-232 serial communications cable (Maple Systems P/N 7431-0048) to the proper COM port on your computer and the terminal block pins on the MAP450D. See Figure 13 below for pin assignments.

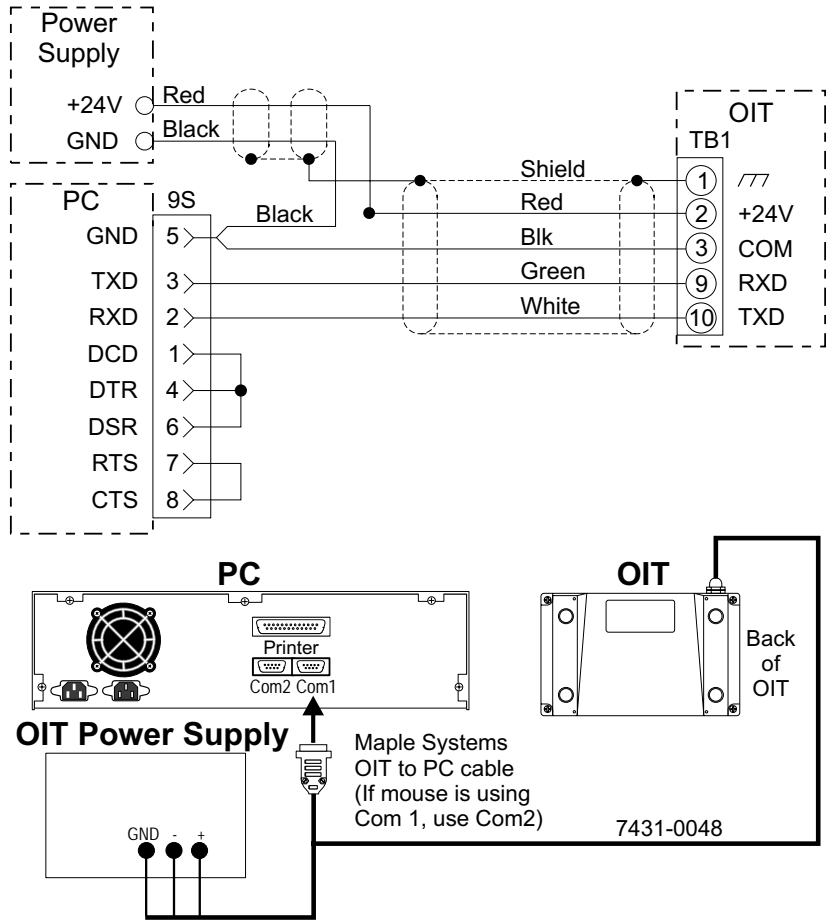

Figure 13 MAP450D to PC RS-232 Communication

# Appendix A

## OIT Hardware Specifications

### Mechanical

Material: Cast aluminum enclosure sealed to NEMA 4/12

Mounting: Panel, pedestal, pendant, or benchtop

Wiring: Unit is field-wired by user to internal terminal block pins

Weight: 2 pounds (0.90 kg)

### Environmental

Operating Temp: +32 to +122°F (0 to +50°C)

Storage Temp: -4 to +158°F (-20 to +70°C)

### Electric Noise Immunity

Emissions: EN55011 (Group 1, Class B) — Generic commercial, light, and heavy industrial environments  
EN50081-1 — Generic domestic and light industrial environments  
EN50081-2 — Generic heavy industrial environment

Immunity: EN50082-1 — Generic domestic and light industrial environments  
EN50082-2 — Generic heavy industrial environment

### Power Requirements

Input Voltage: 12 to 30 VDC

Power Usage: 2.5 watts typical

### Display

Display Type (MAP450D-003): Liquid Crystal Display (LCD)—5 x 7 dot matrix with cursor

Display Type (MAP450D-004): Backlit Liquid Crystal Display (LCD)—5 x 7 dot matrix with cursor

Display Character Size: 2 lines by 40 characters, 0.2 inches (5 mm) high

Display Viewing Angle: Approximately 120 degrees

### Keypad

Key Type: Membrane switch

Feedback: Internal buzzer

Layout: 42 alphanumeric keys arranged in 4 rows of 11 keys

Operational Life: Five million operations, minimum

Customizing: Custom keypad overlay available

### Communications

Serial Port: RS-232, RS-422, or RS-485

Baud Rates: 300, 600, 1200, 2400, 4800, 9600, or 19.2k

### Internal Features

Memory: 128K x 8 Flash PROM for firmware, protocol and configuration data—no battery required

# Appendix A (con't)

## Dimensional Outline

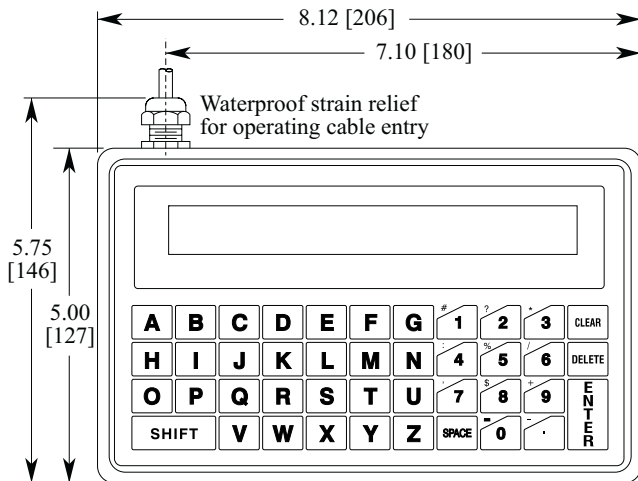

**FRONT VIEW**

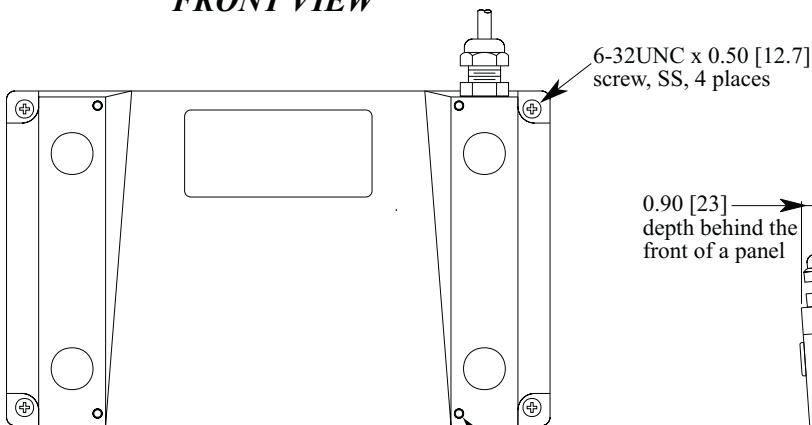

**REAR VIEW**

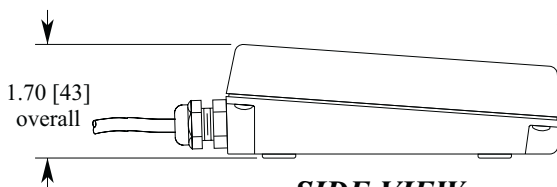

**SIDE VIEW, Free-Standing & Pedestal-Mount**

6-32UNC x 0.30 [7.6] deep threads, for Pedestal Mounting only

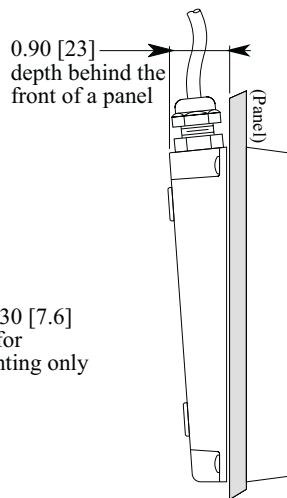

**SIDE VIEW, Panel-Mount**

Dimensions are in inches [mm].

## Appendix B

# Differences Between MAP450D and MAP450B

The MAP450D uses the same enclosure, display, keyboard and overlay as the MAP450B, but includes the following differences:

1. The MAP450D can be configured using the Windows-based STEPware-100 configuration software.
2. The MAP450D stores and displays up to 500 user-definable messages.
3. The MAP450D stores the configuration parameters and user-definable messages in flash memory.
4. The MAP450D is CE certified; it passes strenuous tests for noise immunity and emissions.
5. Local setup mode is entered by pressing and holding the Clear key instead of the S key while the <<<Initializing>>> prompt is on the display. Local setup mode can also be entered after initialization by pressing the Enter key three times.
6. The power supply input requirement is +12 to 30 VDC instead of +5 or 8 to 13 VDC.
7. The MAP450D offers 2 LCD viewing angles instead of 10.
8. The MAP450D uses a non-removable terminal block instead of a removable terminal block for both the communications and power wiring.
9. The Set Serial Interface Command (ESC S) is no longer supported. To maintain backwards compatibility the command is recognized but ignored.