

# Model 29280 Series Slimline Phone User's Guide



## Equipment Approval Information

Your telephone equipment is approved for connection to the Public Switched Telephone Network and is in compliance with parts 15 and 68, FCC Rules and Regulations and the Technical Requirements for Telephone Terminal Equipment published by ACTA.

### 1 Notification to the Local Telephone Company

On the bottom of this equipment is a label indicating, among other information, the US number and Ringer Equivalence Number (REN) for the equipment. You must, upon request, provide this information to your telephone company.

The REN is useful in determining the number of devices you may connect to your telephone line and still have all of these devices ring when your telephone number is called. In most (but not all) areas, the sum of the RENs of all devices connected to one line should not exceed 5. To be certain of the number of devices you may connect to your line as determined by the REN, you should contact your local telephone company.

A plug and jack used to connect this equipment to the premises wiring and telephone network must comply with the applicable FCC Part 68 rules and requirements adopted by the ACTA. A compliant telephone cord and modular plug is provided with this product. It is designed to be connected to a compatible modular jack that is also compliant. See installation instructions for details.

### Notes

- This equipment may not be used on coin service provided by the telephone company.
- Party lines are subject to state tariffs, and therefore, you may not be able to use your own telephone equipment if you are on a party line. Check with your local telephone company.
- Notice must be given to the telephone company upon permanent disconnection of your telephone from your line.
- If your home has specially wired alarm equipment connected to the telephone line, ensure the installation of this product does not disable your alarm equipment. If you have questions about what will disable alarm equipment, consult your telephone company or a qualified installer.

**US Number is located on the cabinet bottom.**

**REN Number is located on the cabinet bottom.**

### 2 Rights of the Telephone Company

Should your equipment cause trouble on your line which may harm the telephone network, the telephone company shall, where practicable, notify you that temporary discontinuance of service may be required. Where prior notice is not practicable and the circumstances warrant such action, the telephone company may temporarily discontinue service immediately. In case of such temporary discontinuance, the telephone company must: (1) promptly notify you of such temporary discontinuance; (2) afford you the opportunity to correct the situation; and (3) inform you of your right to bring a complaint to the Commission pursuant to procedures set forth in Subpart E of Part 68, FCC Rules and Regulations.

The telephone company may make changes in its communications facilities, equipment, operations or procedures where such action is required in the operation of its business and not inconsistent with FCC Rules and Regulations. If these changes are expected to affect the use or performance of your telephone equipment, the telephone company must give you adequate notice, in writing, to allow you to maintain uninterrupted service.

## Interference Information

This device complies with Part 15 of the FCC Rules. Operation is subject to the following two conditions: (1) This device may not cause harmful interference; and (2) This device must accept any interference received, including interference that may cause undesired operation. This equipment has been tested and found to comply with the limits for a Class B digital device, pursuant to Part 15 of the FCC Rules. These limits are designed to provide reasonable protection against harmful interference in a residential installation.

Privacy of Communications may not be ensured when using this product.



This equipment generates, uses, and can radiate radio frequency energy and, if not installed and used in accordance with the instructions, may cause harmful interference to radio communications. However, there is no guarantee that interference will not occur in a particular installation.

If this equipment does cause harmful interference to radio or television reception, which can be determined by turning the equipment off and on, the user is encouraged to try to correct the interference by one or more of the following measures:

- Reorient or relocate the receiving antenna (that is, the antenna for radio or television that is "receiving" the interference).
- Reorient or relocate and increase the separation between the telecommunications equipment and receiving antenna.
- Connect the telecommunications equipment into an outlet on a circuit different from that to which the receiving antenna is connected.

If these measures do not eliminate the interference, please consult your dealer or an experienced radio/television technician for additional suggestions. Also, the Federal Communications Commission has prepared a helpful booklet, "How To Identify and Resolve Radio/TV Interference Problems." This booklet is available from the U.S. Government Printing Office, Washington, D.C. 20402. Please specify stock number 004-000-00345-4 when ordering copies.

Notice: The changes or modifications not expressly approved by the party responsible for compliance could void the user's authority to operate the equipment.

 THE LIGHTNING FLASH AND ARROW HEAD WITHIN THE TRIANGLE IS A WARNING SIGN ALERTING YOU OF "DANGEROUS VOLTAGE" INSIDE THE PRODUCT.	<b>CAUTION:</b> RISK OF ELECTRIC SHOCK DO NOT OPEN  CAUTION: TO REDUCE THE RISK OF ELECTRIC SHOCK, DO NOT REMOVE COVER (OR BACK). NO USER SERVICEABLE PARTS INSIDE. REFER SERVICE TO QUALIFIED SERVICE PERSONNEL.	 THE EXCLAMATION POINT WITHIN THE TRIANGLE IS A WARNING SIGN ALERTING YOU OF IMPORTANT INSTRUCTIONS ACCOMPANYING THE PRODUCT.
SEE MARKING ON BOTTOM / BACK OF PRODUCT		

**WARNING: TO PREVENT FIRE OR ELECTRICAL SHOCK HAZARD, DO NOT EXPOSE THIS PRODUCT TO RAIN OR MOISTURE.**

## Hearing Aid Compatibility (HAC)

This telephone system meets FCC standards for Hearing Aid Compatibility.

## Introduction

Your telephone is designed to give you flexibility in use and high quality performance. To get the most from your new telephone, we suggest that you take a few minutes right now to read through this instruction manual.

 **CAUTION: When using telephone equipment, there are basic safety instructions that should always be followed. Refer to the IMPORTANT SAFETY INSTRUCTIONS provided with this product and save them for future reference.**

**NOTE: This phone uses Touch-Tone dialing service only. For this telephone to function properly, you must use Touch-Tone service available through your local telephone company.**

## Before You Begin

### Telephone Jack Requirements

To use this phone, you need an RJ11C type modular telephone jack, which might look like the one pictured here, installed in your home. If you don't have a modular jack, call your local phone company to find out how to get one installed.

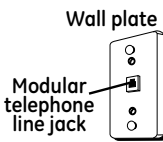

## Important Installation Information

- Never install telephone wiring during a lightning storm.
- Never install telephone jacks in wet locations unless the jack is specifically designed for wet locations.
- Never touch non-insulated telephone wires or terminals, unless the telephone line has been disconnected at the network interface.
- Use caution when installing or modifying telephone lines.
- Temporarily disconnect any equipment connected to the phone such as faxes, other phones, or modems.

## Handset Layout

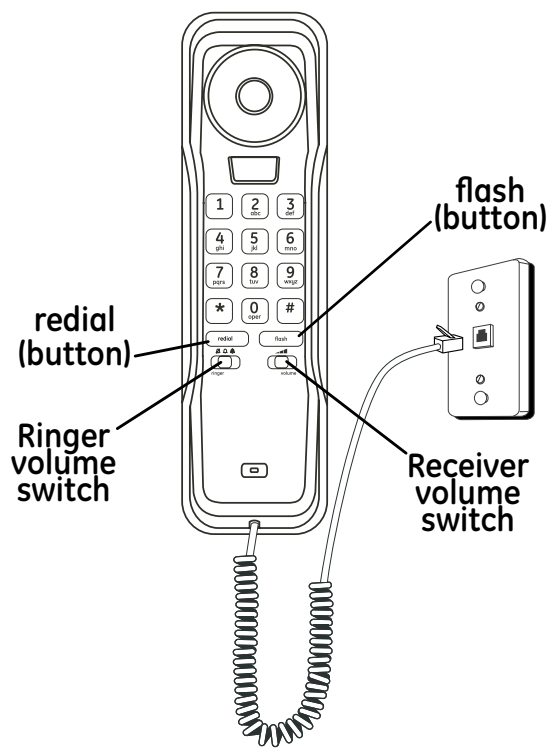

## Installing the Phone

Your telephone should be placed on a level surface such as a desk or table top, or you can mount it on a wall. A desktop/wall mounting pedestal is built into the base of the phone.

- Slide the RINGER volume switch (on the handset) to the desired volume.
- Set the receiver volume switch (on the handset) to the desired listening volume.
- Plug the telephone line cord into a modular wall phone jack.
- Store the extra cord in the grooves in the base.

## Wall Mount Installation

Your telephone may also be mounted on a wall plate (not included).

**NOTE: To prevent the handset from falling out of the cradle while the phone is hanging on the wall, you must reverse the handset hook (located on the base).**

- Push the handset hook up and out of the slot on the base with your thumb, rotate the hook 180°, and replace it back in the slot.
- Plug the telephone line cord into a modular wall phone jack.
- Slip the mounting holes on the base over the wall plate posts and firmly slide the unit down into place (wall plate not included).

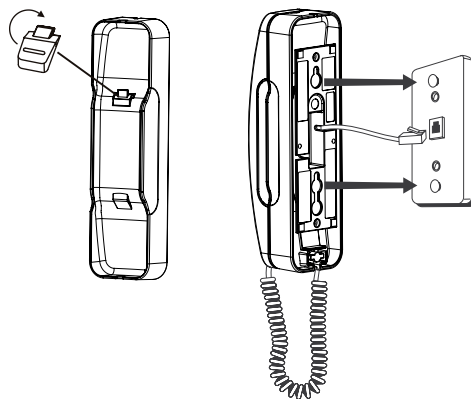

## Telephone Operation

### Redial

This unit redials up to 32 digits. To automatically redial the last number you called:

- Pick up the handset and wait for a dial tone.
- Press the **redial** button.

### Flash



Press the **flash** button to activate custom calling services such as call waiting or call transfer. Custom calling services are provided by the phone company.

### Receiver Volume

You may control the listening level with the volume switch on the bottom of the handset. It has 3 levels: lo, mid, and high.

### Ringer Volume

You may control the ringer volume level with the switch located below the redial button on the handset.

-  = ringer tone will be loud
-  = ringer tone will be low
-  = telephone will not ring

## Troubleshooting Tips

No dial tone.

- Press and release the hook switch. Check the hook switch: Does it fully extend when the handset is lifted from the cradle?

Phone doesn't ring.

- Make sure RINGER switch (located on the handset) is set to loud or low.
- Are you using too many phones on one line? (The total REN of all phones on the same line should not be greater than the maximum REN for your calling area. See Equipment Approval Information).

Other party cannot hear you.

- Make sure phone cord is securely plugged in.
- Make sure extension phones are on the hook at the same time you're using the phone. It is normal for the volume to drop when additional extension phones are used at the same time.

Phone "howls" when handset is placed near the base and handset volume level is too high.

- This is normal feedback due to handset volume level being set to maximum.

## General Product Care

To keep your telephone working and looking good, follow these guidelines:

- Avoid putting the phone near heating appliances and devices that generate electrical noise (for example, motors or fluorescent lamps).
- Do not expose to direct sunlight or moisture.
- Avoid dropping and other rough treatment to the phone.
- Clean with a soft cloth.
- Never use a strong cleaning agent or abrasive powder because this will damage the finish.
- Retain the original packaging in case you need to ship the phone at a later date.

## Warranty Assistance

If trouble is experienced with this equipment, for warranty information, please contact customer service at **1-800-448-0329**.

If the equipment is causing harm to the telephone network, the telephone company may require that you disconnect the equipment until the problem is resolved.

Any unauthorized repairs, changes or modifications not expressly approved by Thomson Inc. could void the user's authority to operate this product. For instructions on how to obtain a replacement unit, refer to the warranty included in this guide or call customer service at **1-800-448-0329**.

Or refer inquiries to:

**Thomson Inc.**  
**Manager, Consumer Relations**  
**P O Box 1976**  
**Indianapolis, IN 46206**

Attach your sales receipt to this booklet for future reference or jot down the date this product was purchased or received as a gift. This information will be valuable if service should be required during the warranty period.

Purchase date \_\_\_\_\_

Name of store \_\_\_\_\_

## Limited Warranty

**What your warranty covers:**

- Defects in materials or workmanship.

**For how long after your purchase:**

- One year, from date of purchase. (The warranty period for rental units begins with the first rental or 45 days from date of shipment to the rental firm, whichever comes first.)

**What we will do:**

- Provide you with a new unit. The exchange unit is under warranty for the remainder of the original product's warranty period.

**How you get service:**

- Properly pack your unit. Include any cables, etc., which were originally provided with the product. We recommend using the original carton and packing materials.
- "Proof of purchase in the form of a bill of sale or receipted invoice which is evidence that the product is within the warranty period, must be presented to obtain warranty service." For rental firms, proof of first rental is also required. Also print your name and address and a description of the defect. Send via standard UPS or its equivalent to:

**Thomson Inc.**  
**11721 B Alameda Ave.**  
**Socorro, Texas 79927**

- Insure your shipment for loss or damage. Thomson Inc. accepts no liability in case of damage or loss.
- A new will be shipped to you freight prepaid.

**What your warranty does not cover:**

- Customer instruction. (Your Owner's Manual provides information regarding operating instructions and user controls. Any additional information, should be obtained from your dealer.)
- Installation and setup service adjustments.
- Batteries.
- Damage from misuse or neglect.
- Products which have been modified or incorporated into other products.
- Products purchased or serviced outside the USA.
- Acts of nature, such as but not limited to lightning damage.

**Product Registration:**

- Please visit [www.ge.com/phones](http://www.ge.com/phones) to register your unit. It will make it easier to contact you, should it ever be necessary. Registration is not required for warranty coverage.

**Limitation of Warranty:**

- THE WARRANTY STATED ABOVE IS THE ONLY WARRANTY APPLICABLE TO THIS PRODUCT. ALL OTHER WARRANTIES, EXPRESS OR IMPLIED (INCLUDING ALL IMPLIED WARRANTIES OF MERCHANTABILITY OR FITNESS FOR A PARTICULAR PURPOSE) ARE HEREBY DISCLAIMED. NO VERBAL OR WRITTEN INFORMATION GIVEN BY THOMSON INC., ITS AGENTS, OR EMPLOYEES SHALL CREATE A WARRANTY OR IN ANY WAY INCREASE THE SCOPE OF THIS WARRANTY.**
- REPAIR OR REPLACEMENT AS PROVIDED UNDER THIS WARRANTY IS THE EXCLUSIVE REMEDY OF THE CONSUMER. THOMSON INC. SHALL NOT BE LIABLE FOR INCIDENTAL OR CONSEQUENTIAL DAMAGES RESULTING FROM THE USE OF THIS PRODUCT OR ARISING OUT OF ANY BREACH OF ANY EXPRESS OR IMPLIED WARRANTY ON THIS PRODUCT. THIS DISCLAIMER OF WARRANTIES AND LIMITED WARRANTY ARE GOVERNED BY THE LAWS OF THE STATE OF INDIANA. EXCEPT TO THE EXTENT PROHIBITED BY APPLICABLE LAW, ANY IMPLIED WARRANTY OF MERCHANTABILITY OR FITNESS FOR A PARTICULAR PURPOSE ON THIS PRODUCT IS LIMITED TO THE APPLICABLE WARRANTY PERIOD SET FORTH ABOVE.**

**How state law relates to this warranty:**

- Some states do not allow the exclusion nor limitation of incidental or consequential damages, or limitations on how long an implied warranty lasts so the above limitations or exclusions may not apply to you.
- This warranty gives you specific legal rights, and you also may have other rights that vary from state to state.

**If you purchased your product outside the USA:**

- This warranty does not apply. Contact your dealer for warranty information.

Visit the GE website at: [www.GE.com/phones](http://www.GE.com/phones)



Model 29280  
00021390 (Rev. 1 Dom E/S)  
08-05  
Printed in China

Thomson Inc.  
101 West 103rd St.  
Indianapolis, IN 46290-1102  
© 2008 Thomson Inc.  
Trademark(s) ® Registered  
Marca(s) Registrada(s)

