

**Treadmill 93T**  
**General Assembly**

**93T-0XXXX-02**  
**S/N TTD100000**

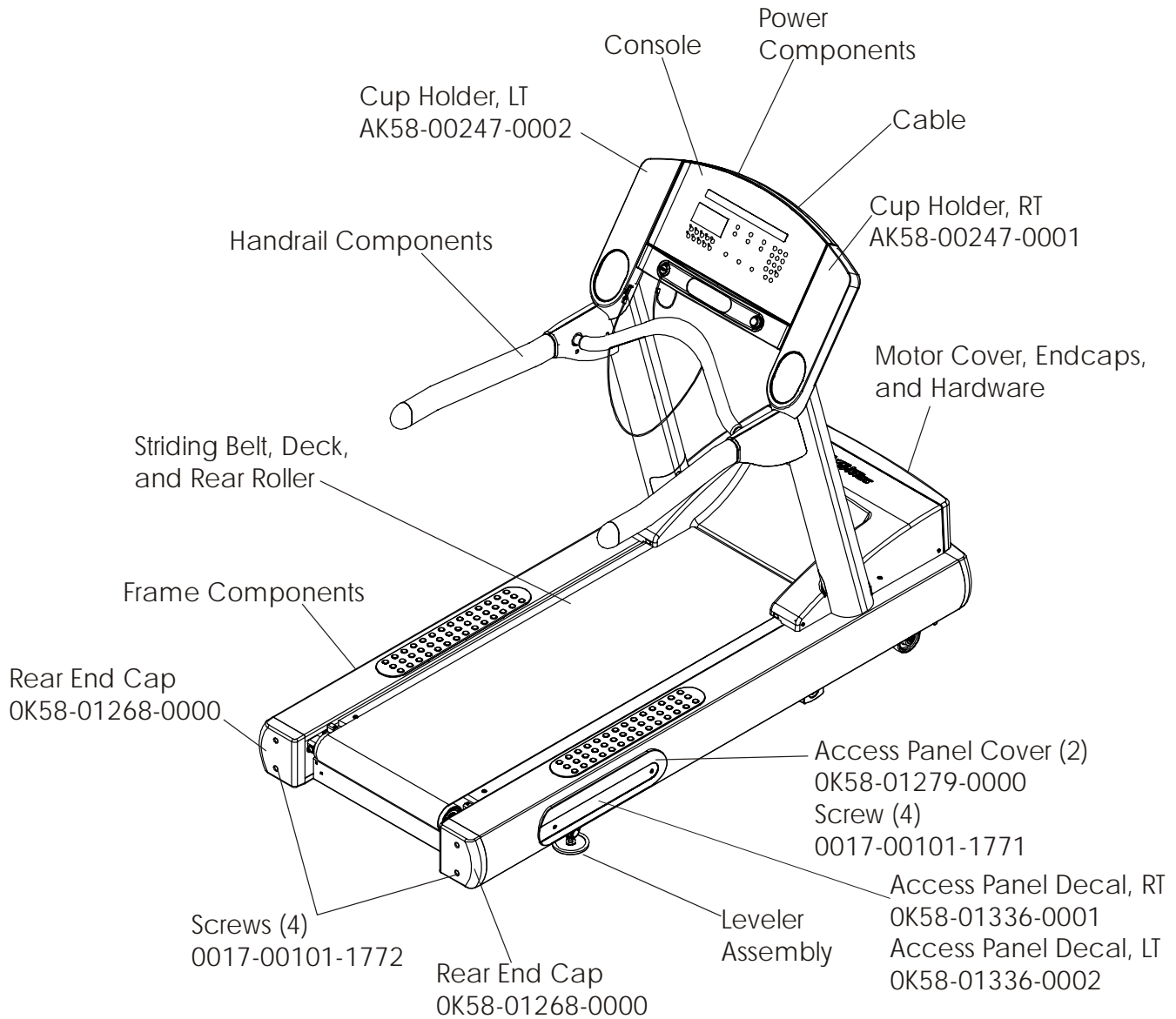

Touch-Up Paint	Color	Container
0017-00008-0196	Silver Bullet	Bottle
0017-00008-0197	Silver Bullet	Spray Can
0017-00008-0198	Stealth Gray	Bottle
0017-00008-0199	Stealth Gray	Spray Can

Manual/Video	Part Number
Operation Manual, Eng	M051-00K58-B081
Service Manual	M051-00K58-A097
Installation Video	M051-00K58-A098
Service Video	M051-00K58-A099

# Treadmill 93T

## Frame Assembly

93T-0XXXX-02  
S/N TTD100000

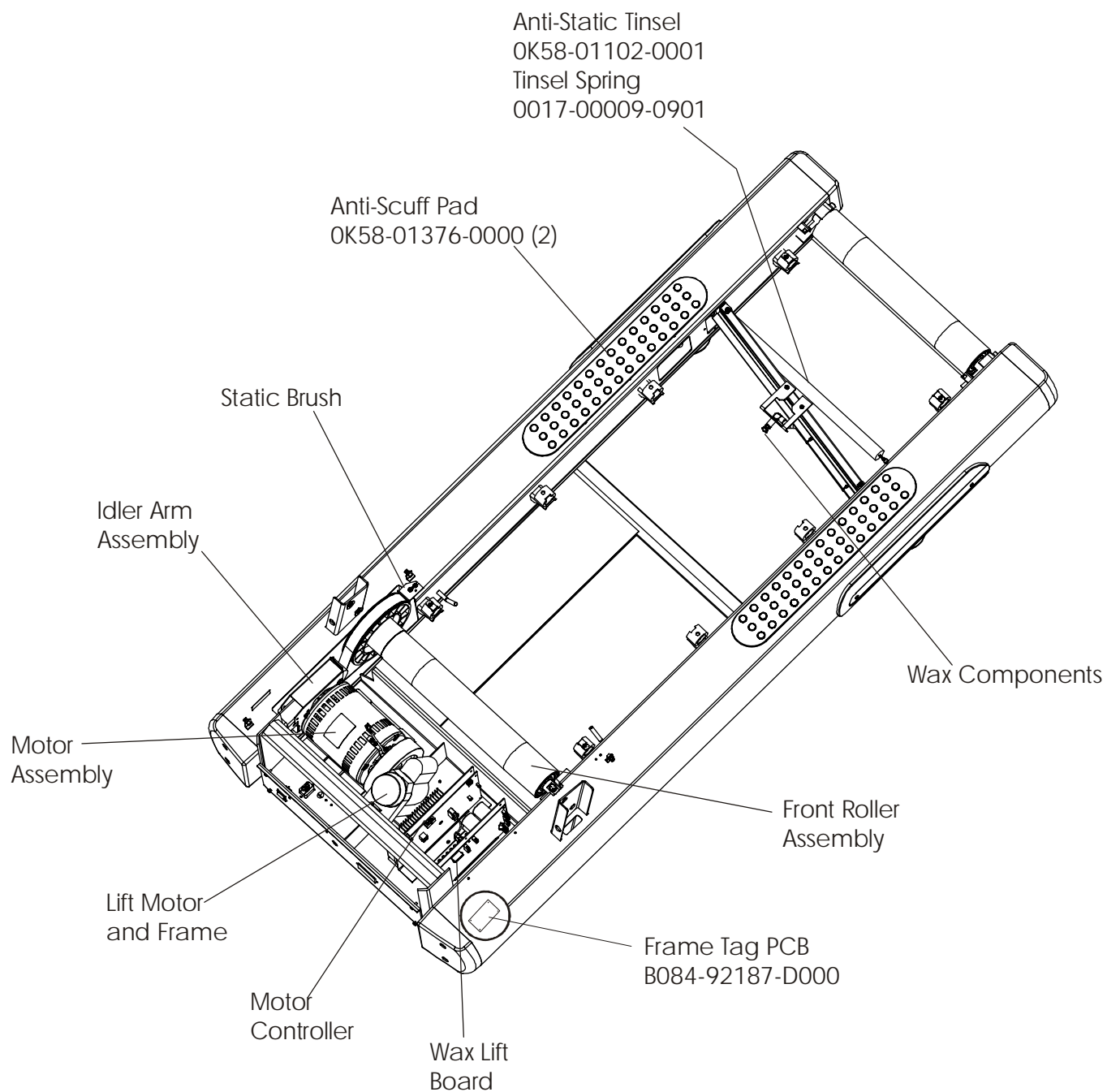

# Treadmill 93T

## Console Assembly

93T-0XXXX-02  
S/N TTD100000

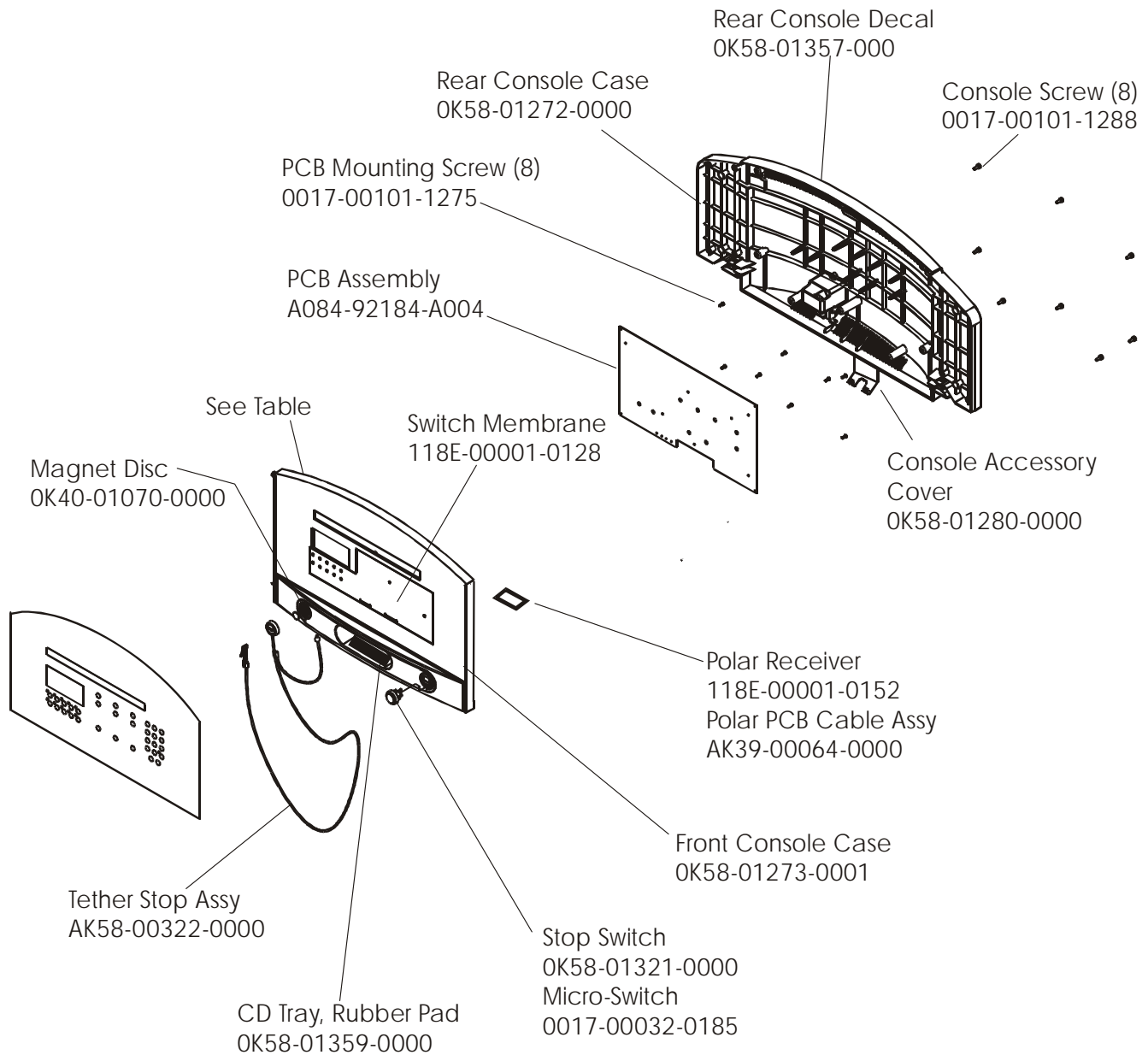

Console Assembly	Overlay Switch Bezel Assy	Language
AK58-00198-0001	AK58-00204-0001	Eng/Met
AK58-00198-0002	AK58-00204-0001	Eng/Eur
AK58-00198-0003	AK58-00204-0003	German
AK58-00198-0004	AK58-00204-0004	Spanish
AK58-00198-0006	AK58-00204-0006	Japanese
AK58-00198-0007	AK58-00204-0007	French
AK58-00198-0008	AK58-00204-0008	Italian
AK58-00198-0009	AK58-00204-0009	Dutch
AK58-00198-00010	AK58-00204-00010	Portuguese
AK58-00198-00011	AK58-00204-00011	Chinese

# Treadmill 93T

## Handrail Assembly

93T-0XXXX-02  
S/N TTD100000

### Hardware Bag Assembly AK58-00227-0001

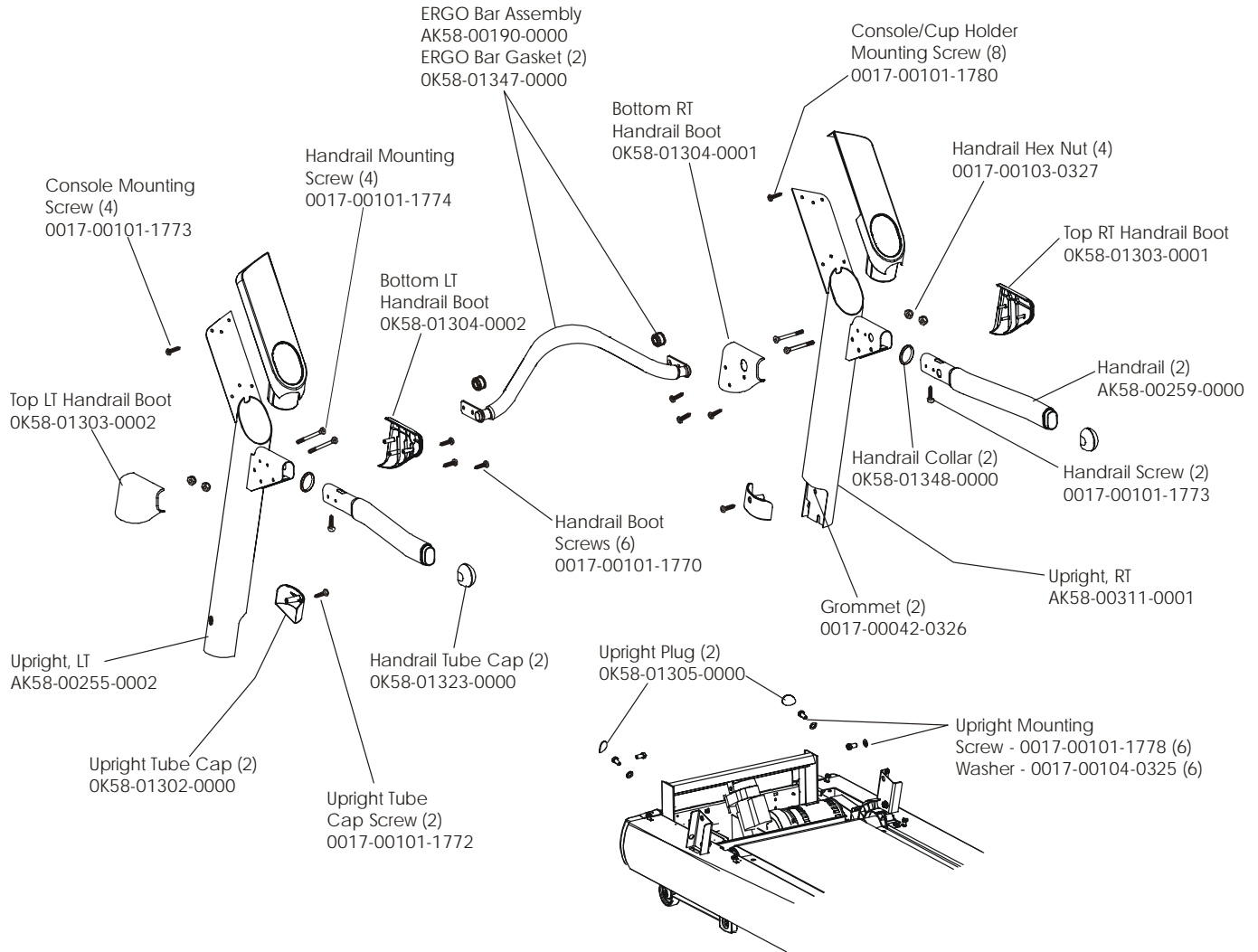

**Treadmill 93T**  
**Covers, End Caps, Hardware**

**93T-0XXXX-02**  
**S/N TTD100000**

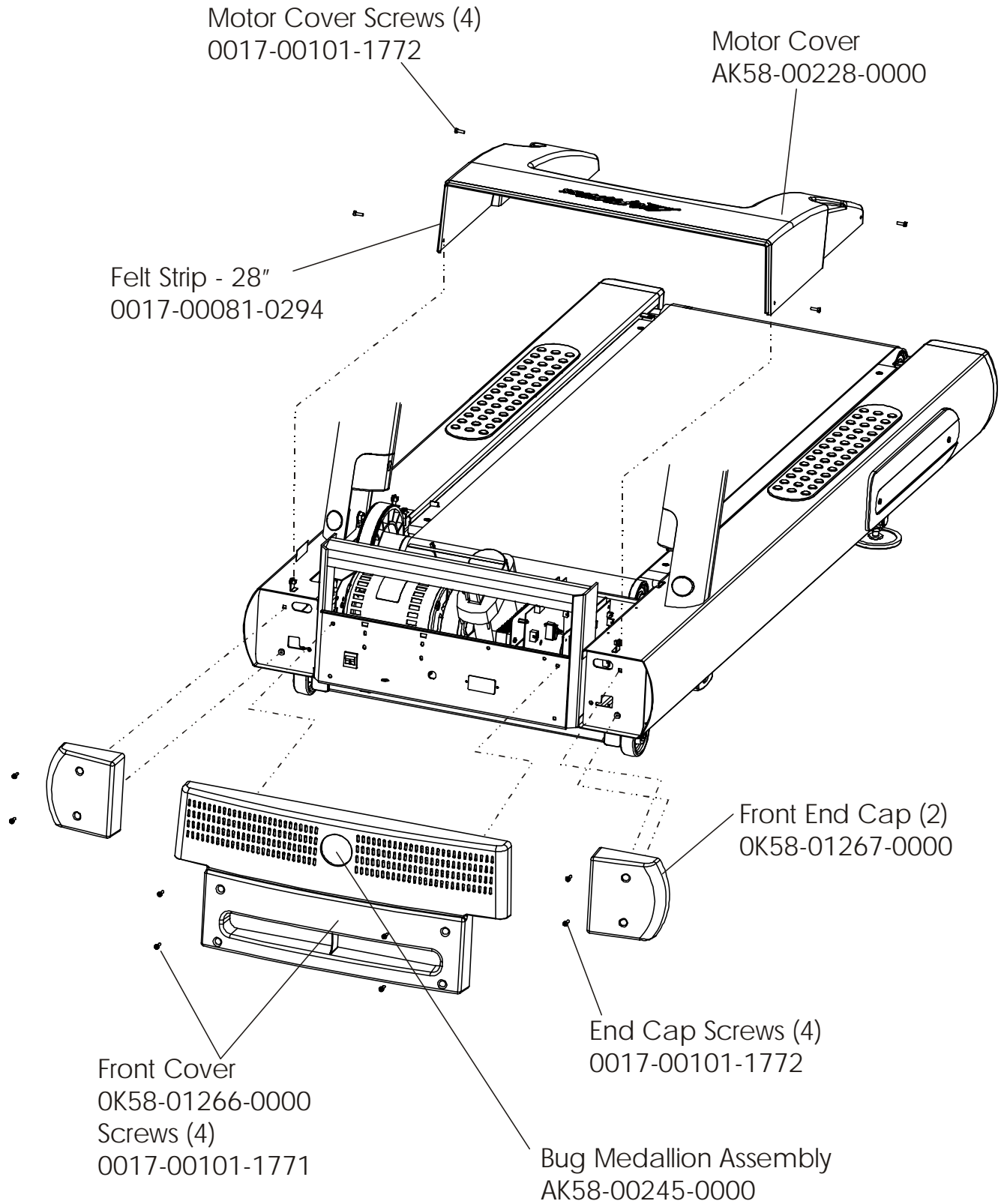

# Treadmill 93T

## Belt, Deck, Rear Roller

93T-0XXXX-02  
S/N TTD100000

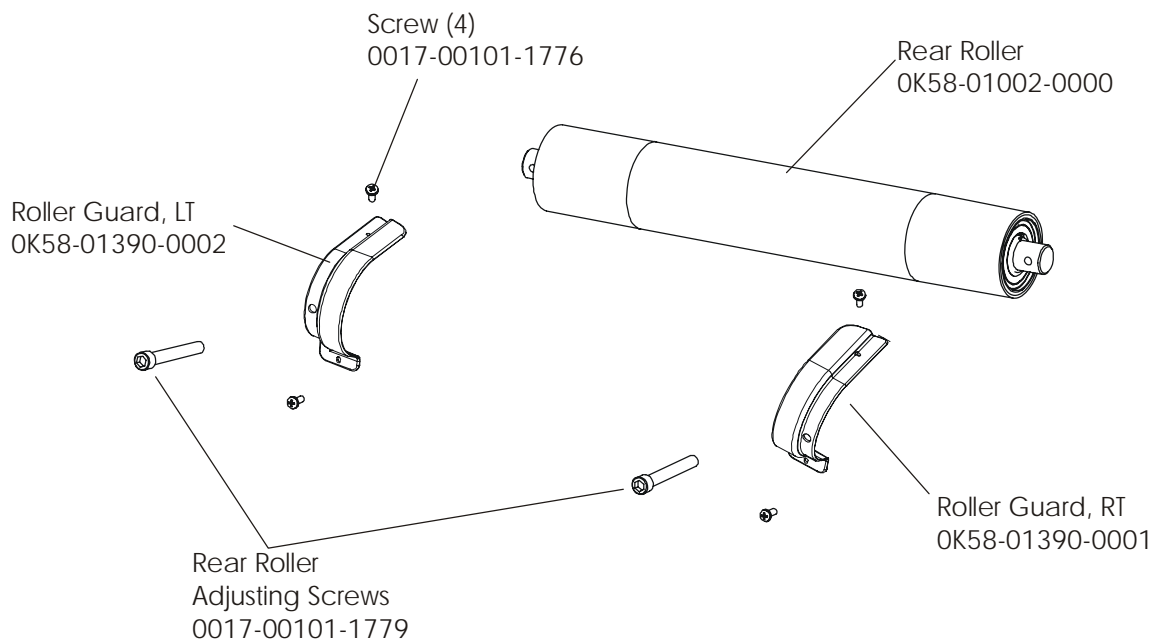
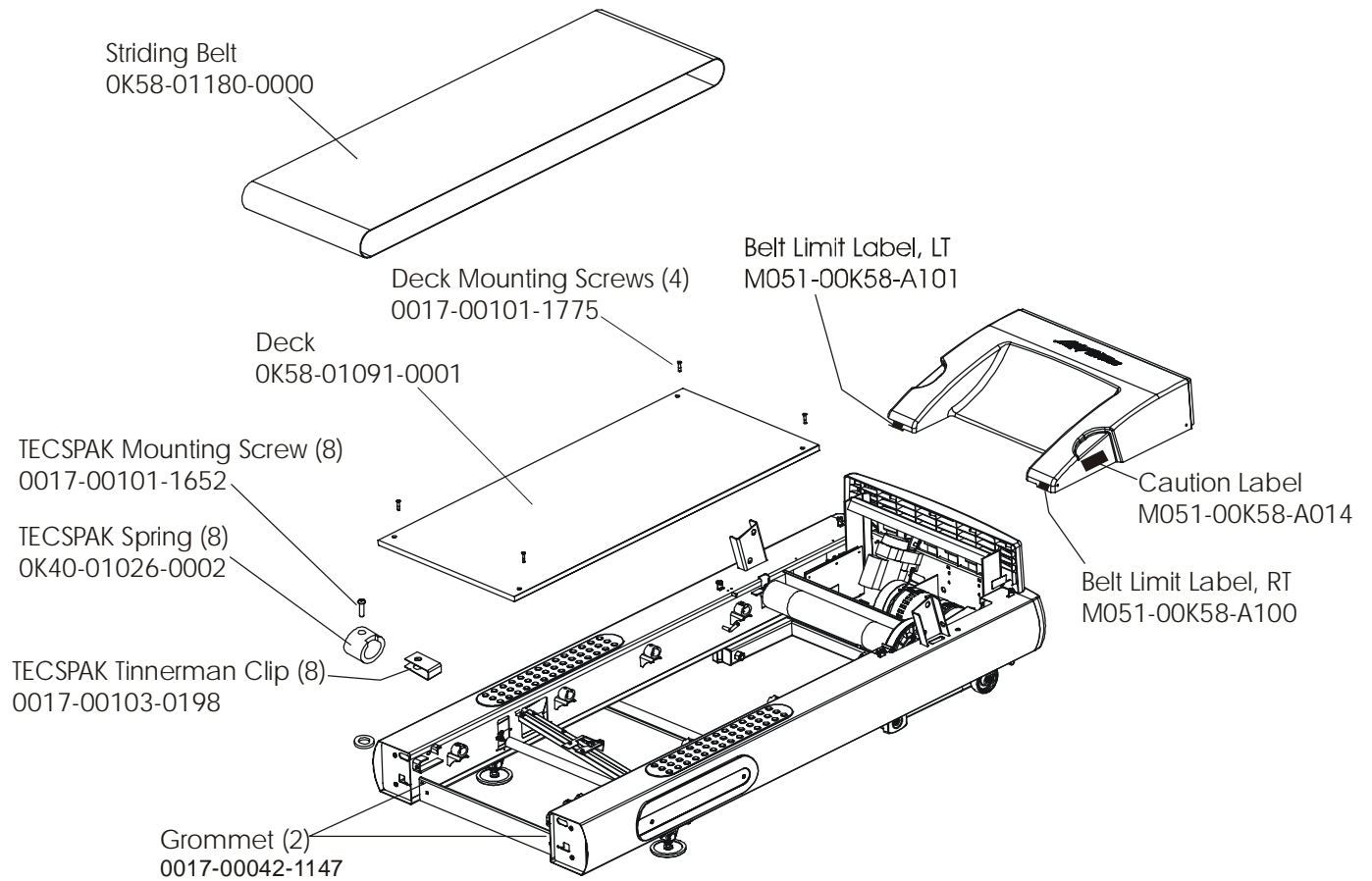

# Treadmill 93T

## Lift Motor and Frame

93T-0XXXX-02  
S/N TTD100000

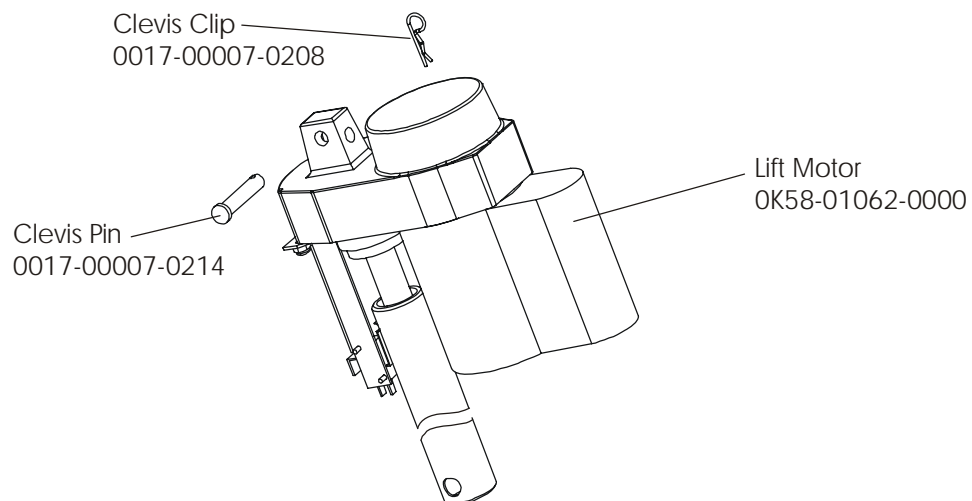
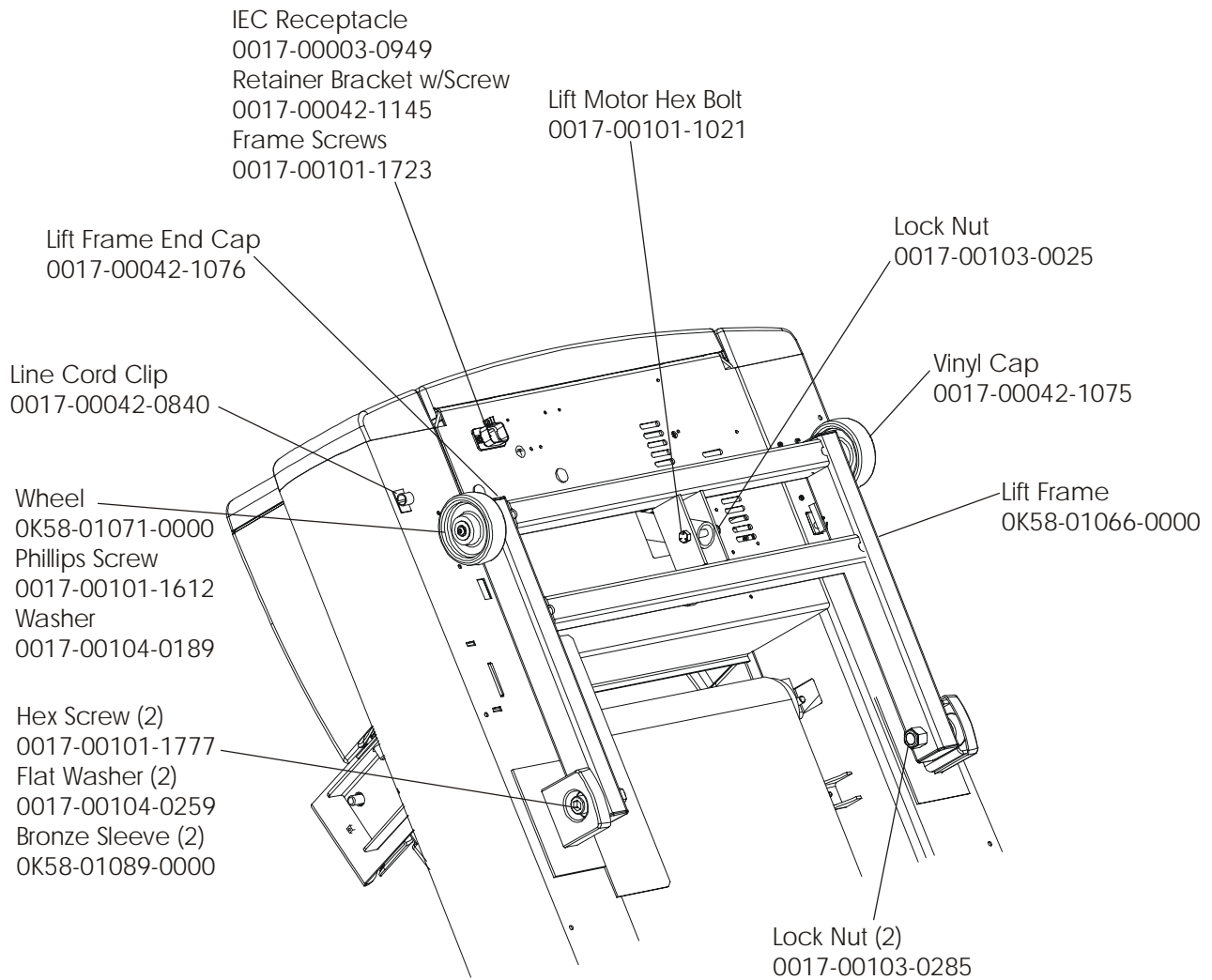

**Treadmill 93T**  
**Wax/Lift Assembly**

**93T-0XXXX-02**  
**S/N TTD100000**

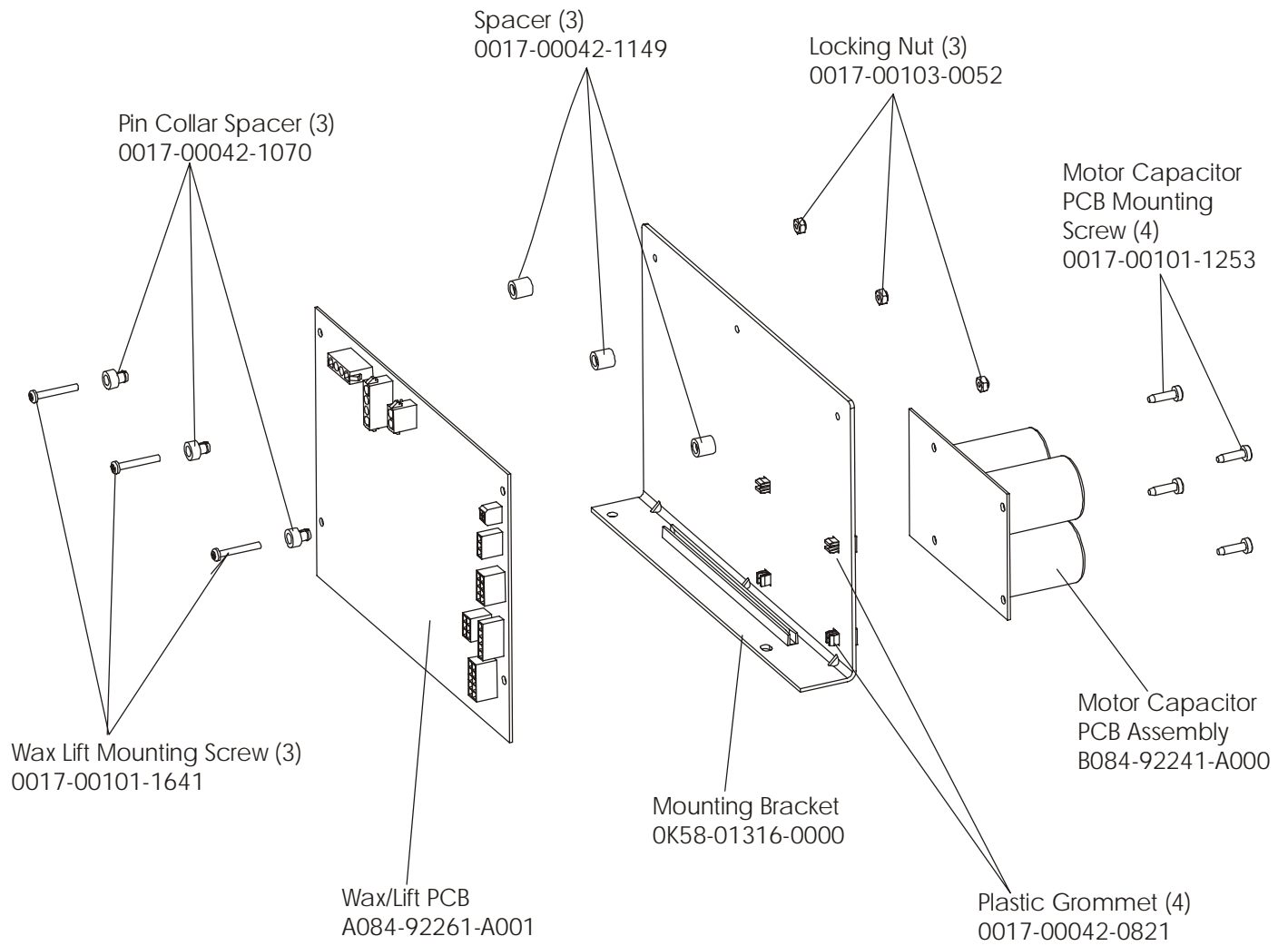



**Treadmill 93T**  
**Motor Controller Assembly**

**93T-0XXXX-02**  
**S/N TTD100000**

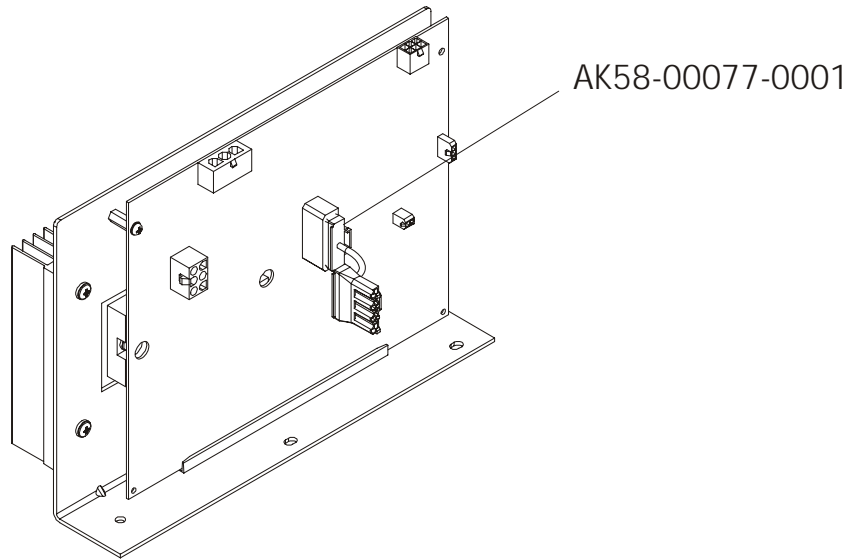

<b>AK60-00171-0000</b>	<b>MTR-CNTRL W/O FERRITE ASY: 100-120</b>
<i><b>Model SKU</b></i>	<i><b>Description</b></i>
93T-0100-02	93T.ENG/ENG.120/60.DOM
93T-0105-02	93T.ENG+MET.100/50.DOM
93T-0300-02	93T.FRN/MET.120/60.DOM
93T-0400-02	93T.SPN/MET.120/60.CON
93T-0705-02	93T.JAP/MET.100/50.DOM
93T-0800-02	93T.POR/MET.120/60.DOM
<b>AK58-00372-0001</b>	<b>MTR-CNTRL W/O FERRITE ASY: 200-240</b>
<i><b>Model SKU</b></i>	<i><b>Description</b></i>
93T-0103-02	93T.ENG+MET.220/60.DOM
93T-0104-02	93T.ENG+MET.240V+. AUS
<b>AK58-00372-0003</b>	<b>MTR-CNTRL W/FERRITE ASY: 200-240</b>
<i><b>Model SKU</b></i>	<i><b>Description</b></i>
93T-0101-02	93T.ENG+MET.230/50.CON
93T-0102-02	93T.ENG+MET.240/50.U.K
93T-0106-02	93T.ENG+MET.200/50.DOM
93T-0109-02	93T.ENG+MET.230/50.U.K
93T-0201-02	93T.GER/MET.230/50.CON
93T-0301-02	93T.FRN/MET.230/50.CON
93T-0401-02	93T.SPN/MET.230/50.CON
93T-0501-02	93T.ITL/MET.230/50.CON
93T-0601-02	93T.DUT/MET.230/50.CON
93T-0706-02	93T.JAP/MET.200/50.DOM
93T-0801-02	93T.POR/MET.230/50.CON

# Treadmill 93T

## Drive Motor Assembly

93T-0XXXX-02  
S/N TTD100000

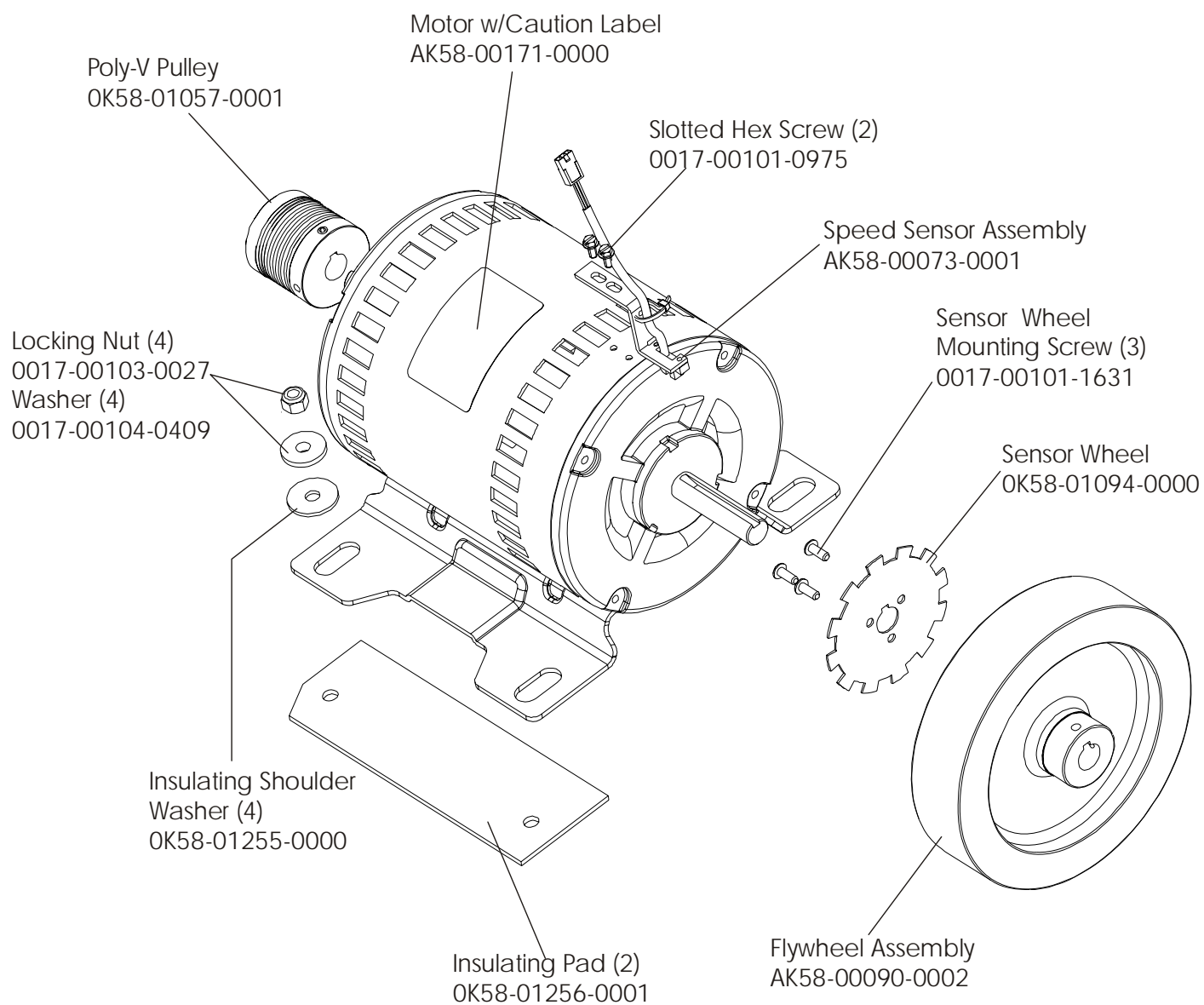

**Treadmill 93T**  
**Wax Components**

**93T-0XXXX-02**  
**S/N TTD100000**

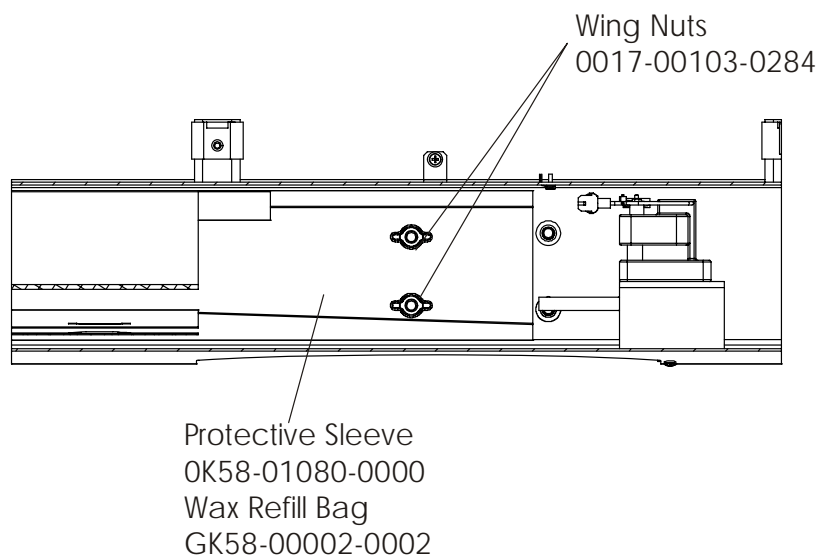
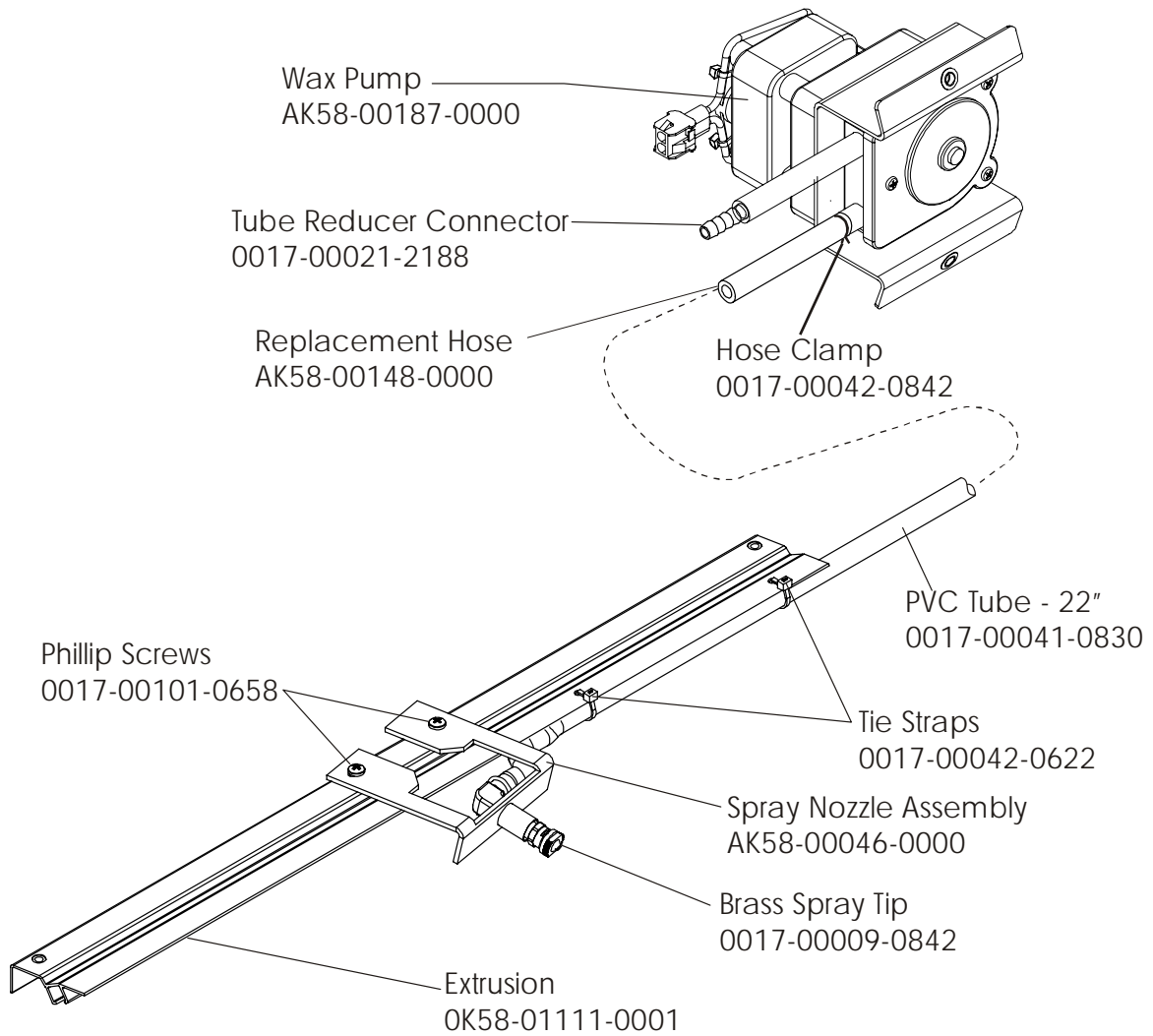

# Treadmill 93T

## Idler Arm Assembly

93T-0XXXX-02  
S/N TTD100000

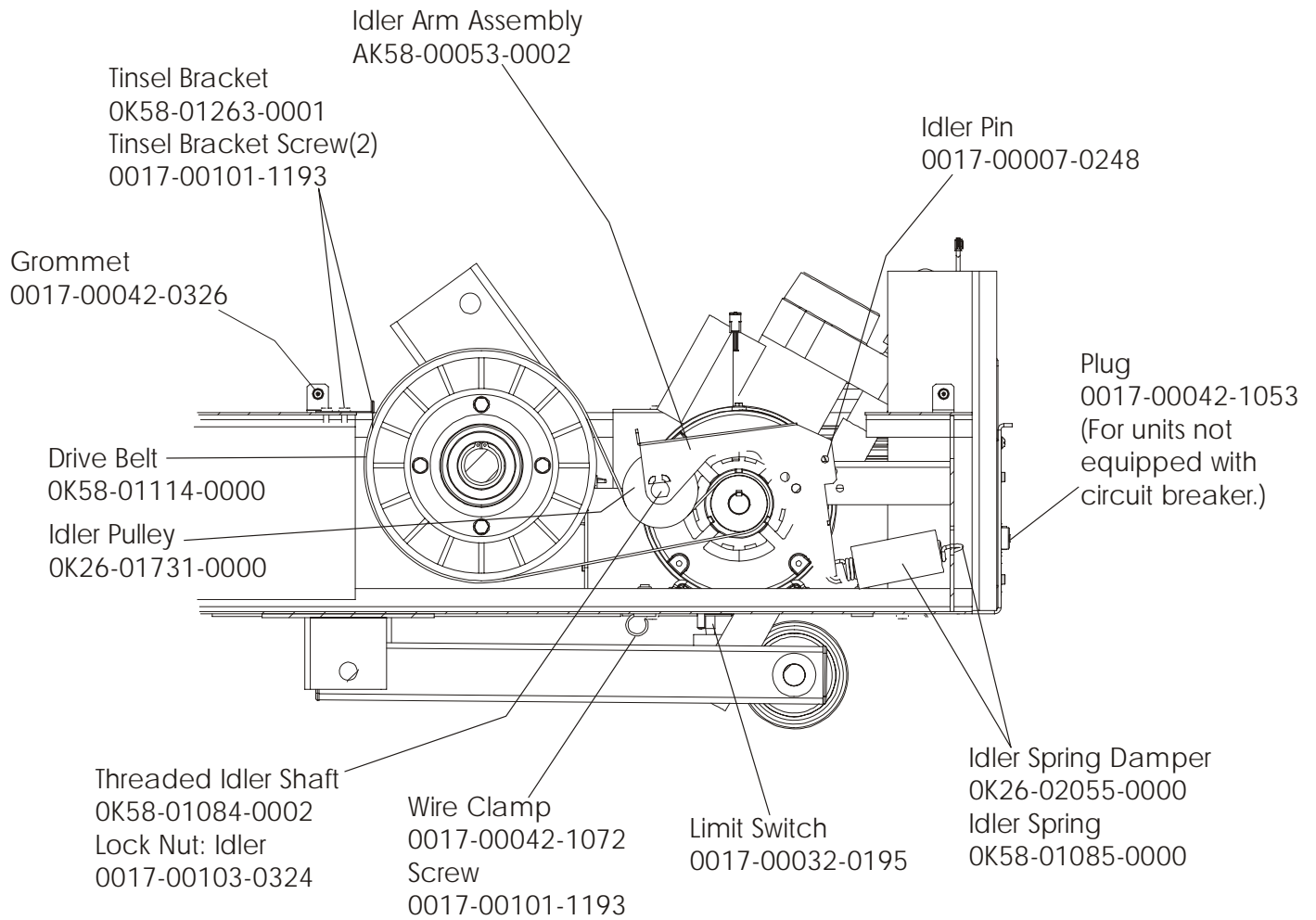

**Treadmill 93T**  
**Leveler Assembly AK58-00370-0000**

**93T-0XXXX-02**  
**S/N TTD100000**

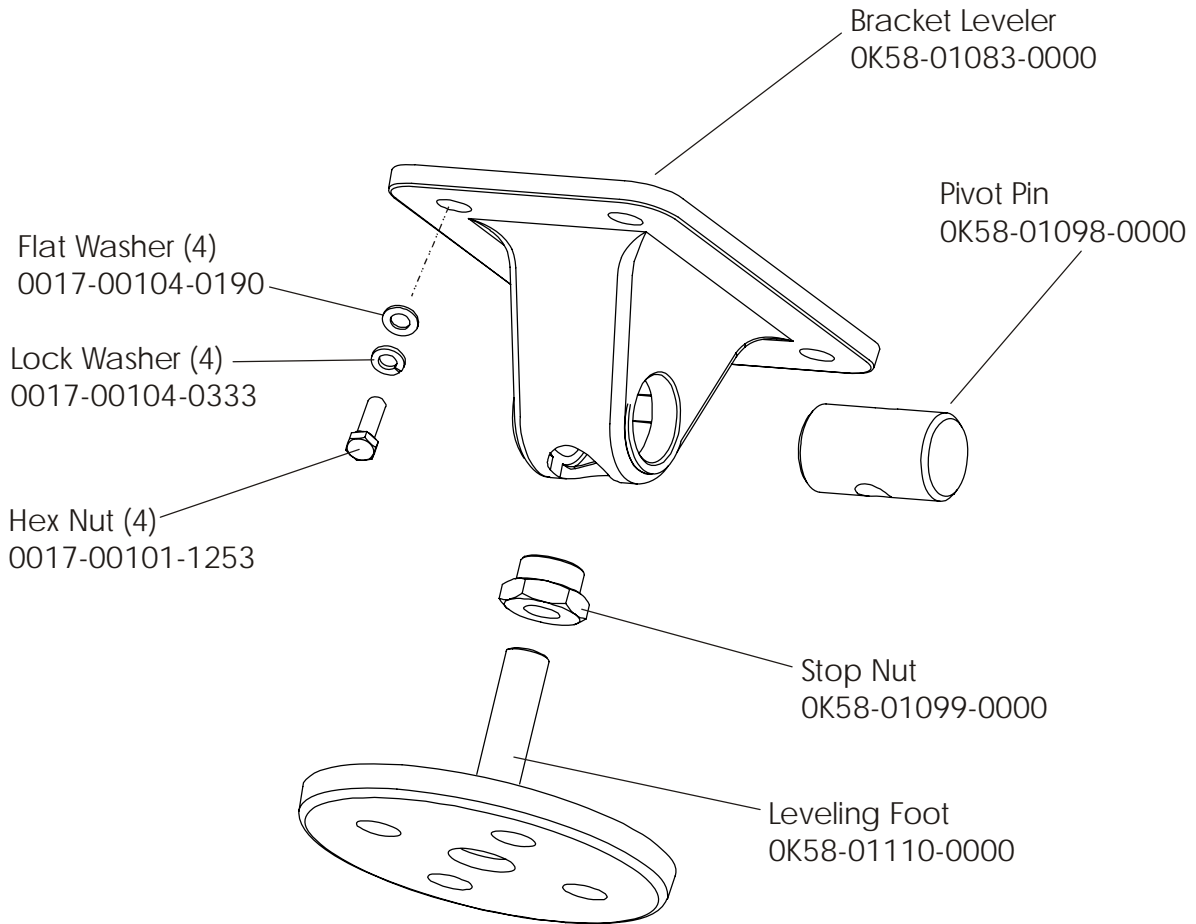

**Treadmill 93T**  
**Front Roller Assembly AK58-00066-0000**

**93T-0XXXX-02**  
**S/N TTD100000**

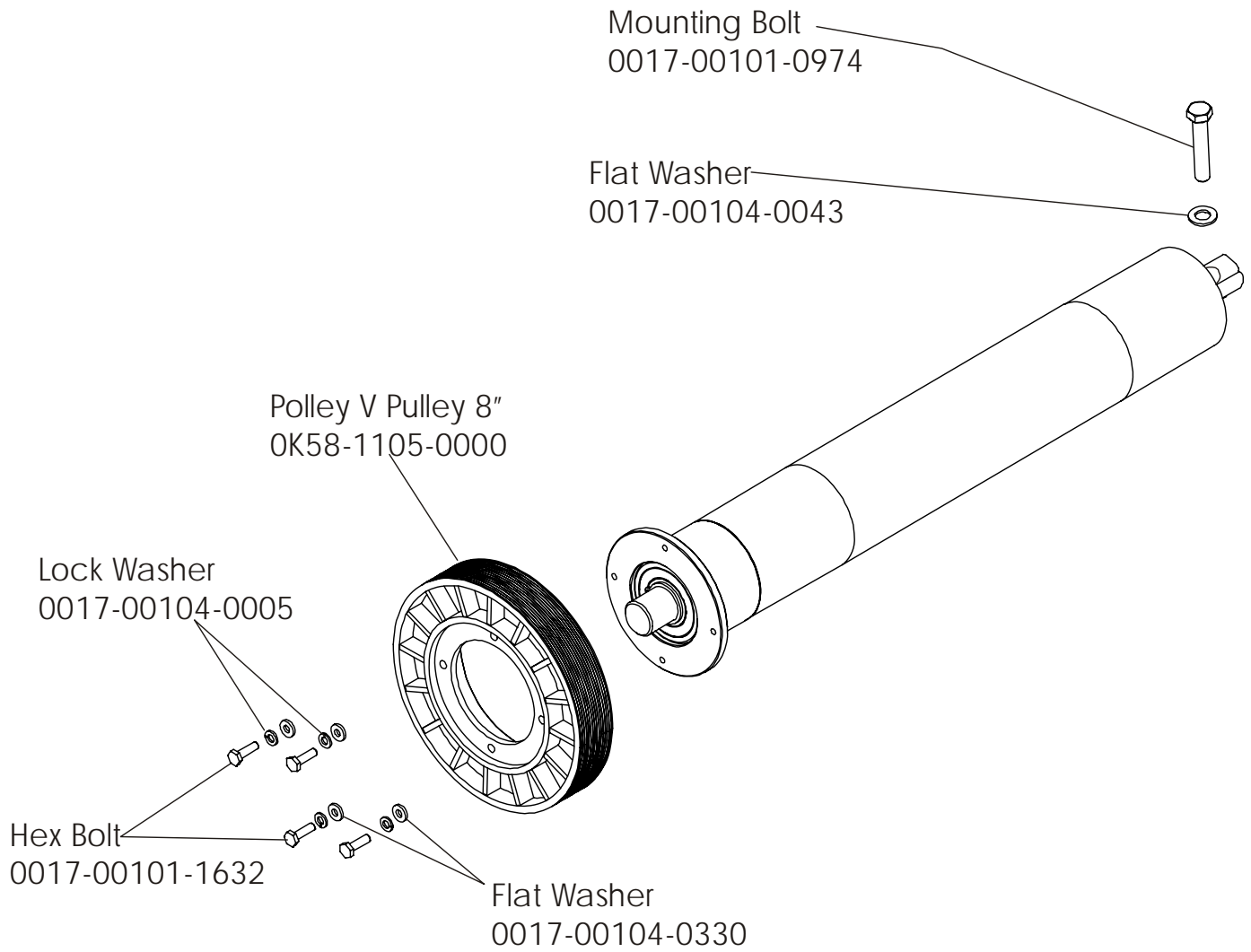

# Treadmill 93T

## Power Components Schematic

**93T-0XXXX-02**  
**S/N TTD100000**

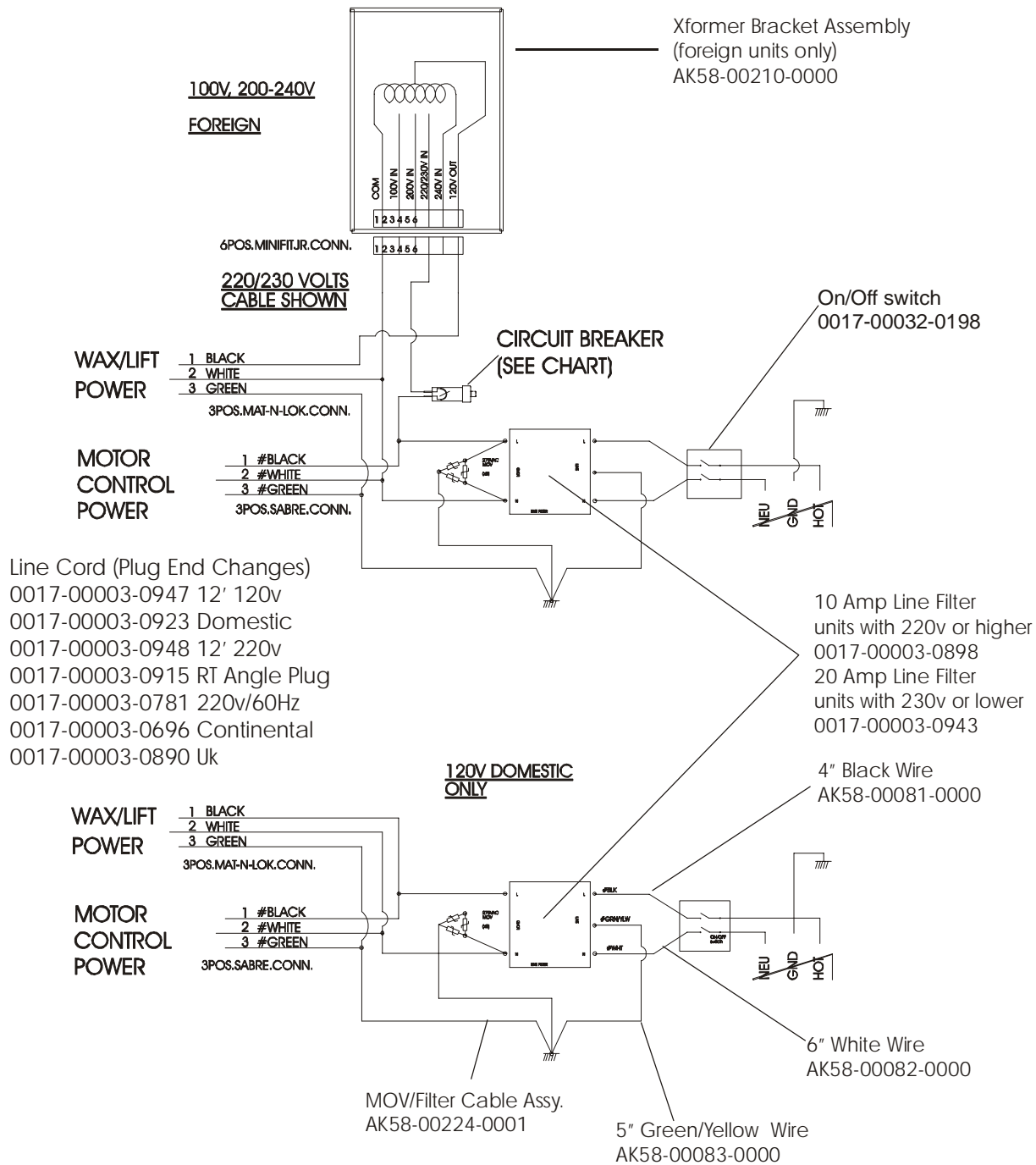

Voltage	Power Cable Part No.	Breaker AMP/Part No.
100v	AK58-00258-0001	4 AMP/0017-00003-0950
200v	AK58-00258-0002	2 AMP/0017-00003-0626
220/230v	AK58-00258-0003	2 AMP/0017-00003-0626
240+	AK58-00258-0004	2 AMP/0017-00003-0626

# Treadmill 93T

## Wax/Lift Power Supply

93T-0XXXX-02  
S/N TTD10000

