



**Help Line**

Australia	+ 1-800-33-11-77
Canada	+ 1-800-665-4339
México	+ 1-800-234-1185
United States	+ 1-800-955-0959

**Fellowes**

Australia	+ 61-3-8336-9700
Benelux	+ 31-(0)-76-523-2090
Canada	+ 1-905-475-6320
Deutschland	+ 49-(0)-5131-49770
France	+ 33-(0)-1-30-06-86-80
Italia	+ 39-(0)-71-730041
Japan	+ 81-(0)-3-5496-2401
Korea	+ 82-(0)-2-3462-2884
Malaysia	+ 60-(0)-35122-1231
Polska	+48-(22)-771-47-40
Spain	+34 91 748 05 01
Singapore	+ 65-6221-3811
United Kingdom	+ 44-(0)-1302-836836
United States	+ 1-630-893-1600



C14

[www.fellowes.com](http://www.fellowes.com)

*Please read these instructions before use.*

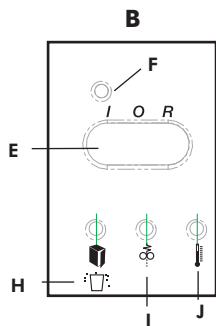
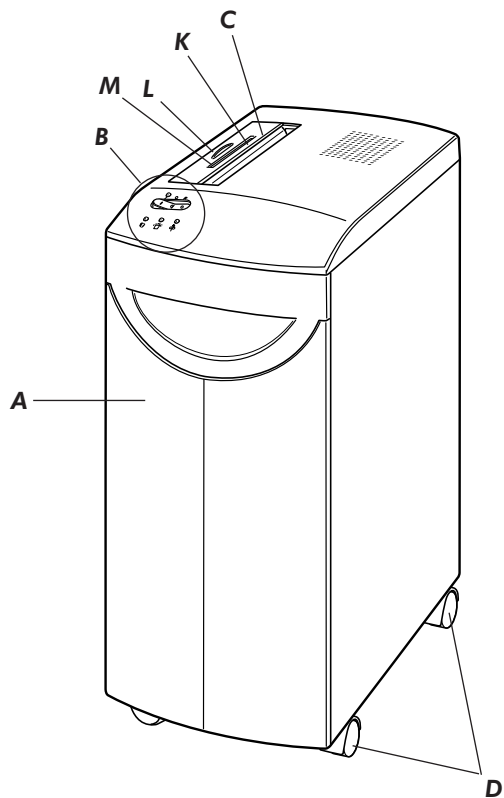

**Fellowes.**

Dear Customer,

Thank you for buying a Fellowes Shredder. We have made many improvements in our shredder since its introduction in 1982. We are confident that it offers you the greatest value for your money in its product category today. We hope it meets – or even exceeds – your expectations.

To ensure years of safe, efficient use, please read these few pages about your new shredder. If this manual doesn't answer all your questions or if you wish to comment on this product, we welcome your call or letter.

Sincerely,

James Fellowes  
Chairman & CEO

## Contents

Product Profile . . . . .	3
Important Safety Instructions . . . . .	3
Set-Up . . . . .	4
Operation . . . . .	4
Maintenance . . . . .	5
Troubleshooting . . . . .	6
Supplies . . . . .	6
Limited Warranty . . . . .	7

## Product Profile

This product is built to shred **paper, staples, small paper clips, credit cards, CDs, and DVDs** (CDs and DVDs in designated slot). It is not built to shred transparencies, adhesive labels, newspaper, cardboard, large paper clips, or plastic (other than items noted above). Attempting to shred items not intended for this shredder may cause damage.



### Confetti-cut (C14)

Sheet capacity*	15 sheets
CD capacity	1
Paper shred size	5/32" x 1 1/2" (3.9 x 38 mm)
Maximum paper width	9" (230 mm)
Recommended daily capacity	100-200 shredding passes
Maximum running time	25 minutes
Automatic cool-down period	40 minutes
Voltage	120V-60Hz 6.0A

\*Based on 20 lb., 8-1/2" x 11" paper with shredder operating at rated voltage; heavier paper, high humidity, or other than rated voltage may reduce sheet capacity.

## IMPORTANT SAFETY INSTRUCTIONS READ ALL INSTRUCTIONS BEFORE USING

### While setting up shredder

- Check shredder for damage or defects; some paper particles in the basket are normal due to product testing and does not indicate a defect.
- If the cord is damaged do not replace cord or use the machine. Return machine for a replacement.
- Avoid touching exposed blades on underside of confetti-cut shredder head.
- Plug power cord in an outlet that can easily be reached. The plug is the primary electrical disconnect.
- Make sure the electrical rating listed on the serial label (located inside, just below top of shredder) matches the available electric power.
- Do not place shredder near or over a heat or water source.

### While operating shredder

- Keep hands and hanging objects (jewelry, ties, loose clothing, long hair, etc.) away from paper entry.
- Keep children and pets away from the shredder.



### When not in use

- Always turn off and unplug shredder.
- Unplug before emptying basket.
- Do not open shredder head: Danger of electric shock. Opening shredder head will void the warranty.



**NOTE:** Do not use flammable synthetic oil, petroleum-based products or aerosols of any kind on or near product at any time.



## Set-Up

- Pull waste basket drawer (A) completely out of cabinet.
- Put waste bag in basket (sample bags provided). Allow edges to overhang. Contact Fellowes to order more bags. (Part #36053).
- Slide waste basket drawer (A) into cabinet. The shredder will not operate if drawer is not pushed all the way into cabinet.
- Casters have been added for your convenience.
- Plug power cord into a convenient outlet.

## Operation

### Control Switches

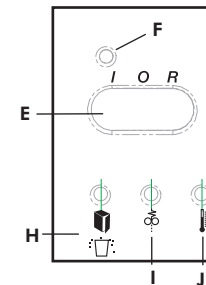

#### Control Switch (E)

**I AUTOMATIC**  
Turns on the automatic-start sensor and the green Ready light.

**O OFF**  
Turns off the automatic-start sensor and the green Ready light.

**R REVERSE**  
Runs shredder in reverse mode. Press and hold to activate.

### Troubleshooting Lights

**Ready Light (F) (Green)**  
Shredder is in automatic start mode.

**Basket Ajar (H)**  
Waste basket drawer is open.

**Basket Full (H)**  
Waste basket is full or paper has collected under cutting cylinders.

**Paper Jam (I)**  
Shredder is jammed (e.g., too much paper fed at one time).

**Overheat Light (J)**  
Shredder has overheated (e.g. shredder has been used for more than 25 minutes).

For convenience and energy savings, your shredder is equipped with an **automatic-start sensor** (K). This means that when the control switch (E) is in the automatic [I] position, the shredder will start running when paper is fed into it. The shredder stops a few seconds after the paper has passed through.

**CAUTION:** The automatic-start sensor cannot tell the difference between paper and other objects. This feature can also be a hazard. Always turn off the shredder when it is not in use. Unplug the shredder if it will not be used for an extended period.



### To shred

- Press control switch (E) to automatic [I] position. Green ready light (F) should turn on.

### PAPER

- Feed paper straight into entry (C), releasing when shredder begins shredding; see **Product Profile** for limits on paper width, shreddable items, sheet capacity, etc.
- Shred no more than 25 minutes; shredding longer will cause shredder to turn itself off for 40 minutes to cool down.
- Press control switch to off [O] position after cutting has stopped.

### CDs, or DVDs

- Slide safety cover (L) to the right to expose the CD entry (M).
- Hold CD, or DVD at the edge and feed one at a time, straight into entry (M) releasing when shredding begins. Shredder will stop when item has passed through entry. CDs and DVDs will be shredded into small particles.
- Slide cover (L) to the left when done shredding media.

**CAUTION:** Do not hold CD or DVD with finger through the center ring while feeding into shredder.

### To empty waste basket

If basket full light (I) is on, follow these steps until light turns off.



- 1 • Press control switch (E) to the off [O] position.
- Open the waste basket drawer (A) and remove full bag.
- Place new bag in basket, then slide drawer into cabinet (Fellowes plastic bag 36053).
- 2 • Press and hold control switch (E) in the reverse [R] position for a few seconds to clear paper shreds that have collected under cutting cylinders.
- Alternate between automatic [I] and reverse [R] for a few seconds in each position.

**CAUTION:** The shredder may be damaged if you alternate too rapidly between automatic and reverse.

- 3 • Unplug shredder and remove wastebasket drawer (A).
- Carefully clear any paper shreds that have collected on under side of paper entry (C).

**CAUTION:** Confetti-cut shredders have exposed blades. Use care when removing paper shreds on underside of paper entry.

### To clear a paper jam

If paper jam light (I) is on, follow these steps until light turns off.



- Check the waste basket and empty if full.
- Press and hold control switch (E) in the reverse [R] position to back paper out of paper entry (C). Try pulling gently on paper to remove it from shredder.
- Alternate between automatic and reverse, if needed:
  - Move control switch to automatic [I] and run for 1-2 seconds.
  - Press and hold control switch (E) in the reverse [R] position for a few seconds.
  - Continue alternating between automatic and reverse until the jam clears.

**CAUTION:** The shredder may be damaged if you alternate too rapidly between automatic and reverse.

## Maintenance

**Empty waste basket regularly** to ensure the smooth functioning of the cutting cylinders. The shredder will not operate when the basket is full.

Oil regularly to ensure proper operation.

If used at or near daily capacity, apply oil every time you empty the basket.

Use Fellowes Powershred Lubricant #35250 or other non-aerosol vegetable-based oil in a long-nozzle container (sample oil provided).

**CAUTION:** Do not use flammable synthetic oil, petroleum-based products, or aerosol lubricants of any kind.



### To oil the cutting cylinders

- Apply oil over full width of cutting cylinders through the paper entry (C).
- Move control switch (E) to automatic [I] and run for 1-2 seconds.
- Press and hold the control switch (E) in reverse [R] for at least 3 seconds.
- Repeat the automatic/reverse sequence 3 or more times.



## Troubleshooting

If there is a problem with your shredder, check these symptoms and remedies. If you cannot solve the problem, contact Fellowes customer service. **Do not open shredder head** to attempt repair. You could be exposed to serious electric shock and will void the warranty.

### Symptom

### Remedy

Ready Light (F) will not light

Make sure shredder is plugged in and the control switch (E) is in the automatic [I] position.

Shredder does not start or stops while shredding

- Make sure shredder is plugged in and control switch (E) is in the automatic [I] position.
- Shredder is jammed. Follow the instructions under **Operation**.

Basket ajar/basket full light (H) is on



Make sure the waste basket (A) is all the way into the cabinet. Empty the waste basket. Follow the instructions under **Operation**.

Paper jam light (I) is on



Clear the paper jam. Follow the instructions under **Operation**.

Overheat light (J) turns on and shredder will not operate.



Wait 40 minutes for shredder to cool down before trying again.

Shredder sheet capacity decreases, noise level increases, or cutting cylinders stop with a squeak or rubbing sound

Oil the cutting cylinders. Follow the instructions under **Maintenance**.

Shredder runs for a few seconds after the paper has cleared the cutters

No action required. This is a self-cleaning function.

## Supplies

The following items for the C14 shredders are available from Fellowes:

Item	Quantity	Part Number
Waste bags (in dispenser)	100/roll	36053
Powershred Lubricant	12 oz. bottle	35250

To purchase supplies, contact Fellowes at the appropriate location listed on the back page of this instruction manual, or visit us at [www.fellowes.com](http://www.fellowes.com).

## Limited Warranty

Fellowes, Inc. ("Fellowes") warrants the cutting cylinders of the machine to be free from defects in material and workmanship for **7 years** from the date of purchase by the original consumer. Fellowes warrants all other parts of the machine to be free of defects in material and workmanship for 1 year from the date of purchase by the original consumer. If any part is found to be defective during the warrant period, your sole and exclusive remedy will be repair or replacement, at Fellowes' option and expense, of the defective part.

This warranty does not apply in cases of abuse, mishandling or unauthorised repair. ANY IMPLIED WARRANTY, INCLUDING THAT OF MERCHANTABILITY OR FITNESS FOR A PARTICULAR PURPOSE, IS HEREBY LIMITED IN DURATION TO THE APPROPRIATE WARRANTY PERIOD SET FORTH ABOVE. In no event shall Fellowes be liable for any consequential or incidental damages attributable to this product. This warranty gives you specific legal rights. You may have other legal rights that vary. The duration, terms and conditions of this warranty are valid worldwide, except where different limitations, restrictions or conditions may be required by local law.

For more details or to obtain service under this warranty, please contact us (see back cover) or your dealer.

Warrantor: Fellowes, Inc.