



IMPORTANT

Do **not** return this product to the store.

For assembly problems or questions contact: Eureka's Customer Service Division toll free at 1-800-282-2886*, 8 a.m. to 7:30 p.m., (CST), Monday - Friday and 10 a.m. to 6:30 p.m. Saturday.

For replacement of broken or missing items to be shipped direct to you, call 1-800-438-7352*, 8 a.m. to 4:45 p.m., (CST), Monday - Friday.

To order replacement parts and accessories call 1-800-438-7352*, 8 a.m. to 4:45 p.m., (CST), Monday - Friday or visit our web site, www.eureka.com.

***En Mexico llame al 5670-6169.**

Index

Important Information ...	2
Assemble	3
Use	3
Accessories	3
Filter	4
Cloth Dust Bag	4
Troubleshooting	5
Warranty	5

Please Retain

We suggest you record the model, type and serial numbers below. They are located on the silver rating plate on your cleaner. For prompt and complete service information, always refer to these numbers when inquiring about service.

Model & Type _____

Serial No. _____

It is also important to keep your receipt as proof of date of purchase.

IMPORTANT SAFEGUARDS

When using an electrical appliance, basic precautions should always be followed, including the following:

READ ALL INSTRUCTIONS BEFORE USING THIS VACUUM CLEANER.

WARNING

To reduce the risk of fire, electric shock, or injury:

- Do not use outdoors or on wet surfaces.
- **Do not leave vacuum cleaner when plugged in.** Turn off the switch and unplug the electrical cord when not in use and before servicing.
- Do not allow to be used as a toy. Close attention is necessary when used by or near children.
- Use only as described in this manual. Use only manufacturer's recommended attachments.
- Do not use with damaged cord or plug. If vacuum cleaner is not working as it should, has been dropped, damaged, left outdoors, or dropped into water, return it to a service center before using.
- Do not pull or carry by cord, use cord as a handle, close door on cord, or pull cord around sharp edges or corners. Do not run vacuum cleaner over cord. Keep cord away from heated surfaces.
- Do not use extension cords or outlets with inadequate current carrying capacity.
- Turn off all controls before unplugging.
- Do not unplug by pulling on cord. To unplug, grasp the plug, not the cord.
- Do not handle plug or vacuum cleaner with wet hands or operate without shoes.
- Do not put any object into openings. Do not use with any opening blocked; keep free of dust, lint, hair, and anything that may reduce airflow.
- This vacuum cleaner creates suction. Keep hair, loose clothing, fingers, and all parts of body away from openings and moving parts.
- Do not pick up anything that is burning or smoking, such as cigarettes, matches, or hot ashes.
- Do not use without dust bag or filter(s) in place.
- Use extra care when cleaning on stairs.
- Do not use to pick up flammable or combustible liquids such as gasoline, or use in areas where they may be present.
- Store your cleaner indoors in a cool, dry area.
- Keep your work area well lighted.
- Unplug electrical appliances before vacuuming them.

SAVE THESE INSTRUCTIONS

To reduce the risk of electric shock, this appliance has a polarized plug (one blade is wider than the other). This plug will fit in a polarized outlet only one way. If the plug does not fit fully into the outlet, reverse the plug. If it still does not fit, contact a qualified electrician to install the proper outlet. Do not change the plug in any way.



DO NOT OIL the motor or the brush roll. The motor and brush roll are permanently sealed and lubricated.

GENERAL INFORMATION

Use the cleaner to pick up dirt and dust particles. Avoid picking up hard or sharp objects that could damage the vacuum cleaner.

Service Information

The instructions in this booklet serve as a guide to routine maintenance. For additional service information, telephone our toll free number for the nearest Eureka Authorized Warranty Station. **You should know the model, type and serial number or date code when you call:**

USA: 1-800-282-2886 Mexico: 5670-6169
Canada: 1-800-282-2886

If you prefer, you can write to The Eureka Company, Service Division, 807 North Main St., Bloomington, Illinois 61701, USA. In Canada, write to The Eureka Company, 866 Langs Drive, Cambridge, Ontario N3H 2N7. Refer to The Eureka Warranty for complete service information.

Automatic Motor Shut-Off

To protect from overheating, this vacuum cleaner is equipped with a thermostat which automatically shuts off the motor if it overheats. Should this happen:

1. **Turn off the switch and unplug the cleaner** because the thermostat will allow the cleaner to automatically start running again when the motor cools (approximately 30 minutes).
2. **Check the hose, bag and filter** regularly, as a clogged hose, full bag or dirty filter could cause the motor to overheat.
3. **Call a Eureka Service Station** if the cleaner will not operate after cooling for approximately 30 minutes.

ASSEMBLY

How to Attach Mounting Bracket and Hose Storage Bracket to Wall (on some models)

Danger: When located in a garage install at least 18 inches (450mm) above floor level. This equipment incorporates parts such as switches, motors or the like that tend to produce arcs or sparks that can cause an explosion.

Mount on a wall where there are no dangerous objects hidden beneath the wall surface like electrical wires, pipes, etc.

To use cleaner when mounted on wall bracket, mount bracket within reach of an electrical outlet. The hose storage bracket can be located anywhere since the hose is removed from the cleaner for storage.

- 1 Hold brackets against wall to mark location for the two screws. Position the brackets against the wall as shown.
- 2 Use a 3/16" drill bit for drilling holes for the two plastic anchors.
- 3 Insert the anchors. Line up the bracket with the anchors.
- 4 Use a screwdriver to drive the screws into the anchors to secure the bracket.

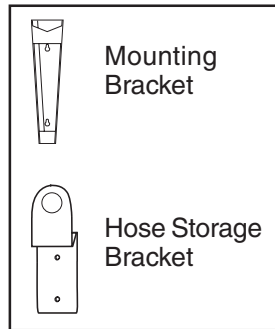

How to Mount your Vacuum Cleaner on Wall Bracket

- 5 Turn the rotating wheel so it faces downward.
- 6 Hook the wheel over the v shaped rail at the top of the mounting bracket and let vacuum rest against the wall.
- 7 Plug the vacuum into an electrical outlet.

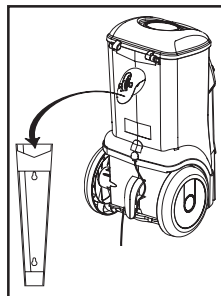

Caution: Unplug cleaner when not in use.

HOW TO USE

- 1 Connect Hose.

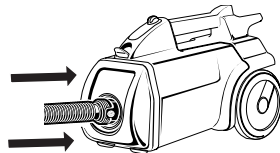

- 2 Store Tools

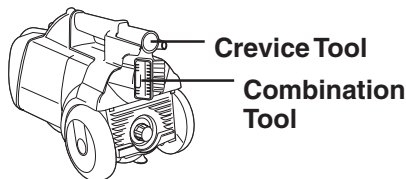

CAUTION: Moving parts. Make sure on/off switch is in off position before plugging in.

- 3 Push ON/OFF Switch (A thermostat automatically shuts the motor off if it overheats, see Automatic Motor Shut-Off)

ON/OFF Switch

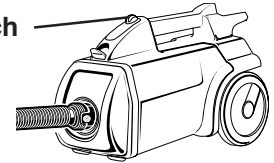

Cleaning Accessories

Slip the circular end of an accessory tool onto the end of the hose handle and twist slightly to secure. If additional reach is needed, place a wand on the hose handle first.

Attach wands and cleaning tools

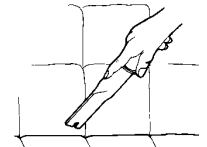
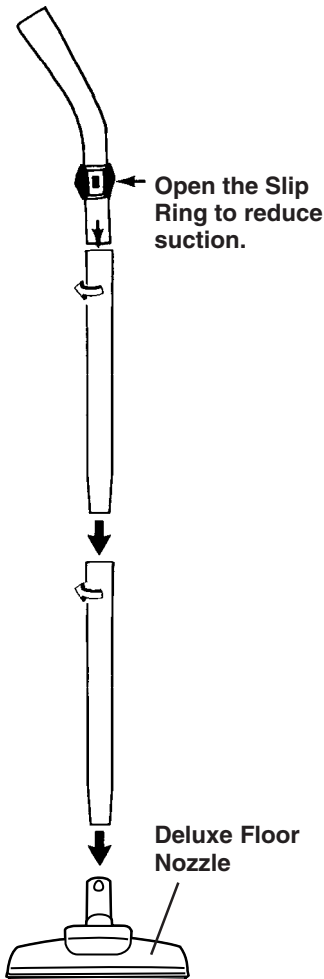

Crevice Tool



Combination Tool

Crevice Tool: For crevices, corners, baseboards, between cushions.

Combination Tool: One tool with bristles for dusting, and nozzle for floors and upholstery.

Deluxe Floor Nozzle: For any type of hard surface floor.

HOW TO MAINTAIN

The instructions given in this booklet serve as a guide to routine maintenance. To avoid unnecessary service calls, check the hose, cloth bag and motor filter often. Clear a clogged hose with the blower, empty the bag if it is full, and clean the motor filter when it is dirty.

Cloth Dust Bag and Filter

The cloth dust bag and motor filter play a very important roll in the efficiency of the vacuum cleaner. The purpose of the cloth dust bag is to trap dirt. If the bag or the motor filter become clogged, no air can pass through the cleaner and no cleaning can take place regardless of how powerful the unit is. To keep the cleaner operating at maximum efficiency, empty the cloth dust bag frequently and clean the filter as needed. Some fine particles can restrict airflow very quickly and will decrease performance even before the cloth dust bag appears to be full. For that reason, when vacuuming carpet fresheners or cleaners, powder, plaster dust, or similar fine substances, the cloth bag needs to be emptied and the filter needs to be cleaned or replaced more often.

How to Empty the Cloth Bag

NOTE: Turn off vacuum and unplug the electrical cord before changing cloth bag or cleaning motor filter. Never operate the vacuum cleaner without the cloth bag or filter.

- 1 Turn off and unplug cleaner.
- 2 Open lid by pushing down on hood latch and lifting lid.

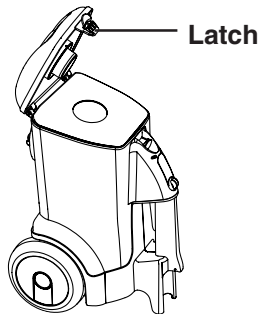

- 3 To empty cloth bag, hold bag over a waste container and slide the bottom clamp off the cloth bag. Shake debris into waste container. Reposition plastic clamp at base of cloth bag.

NOTE: Do not get the cloth bag wet.

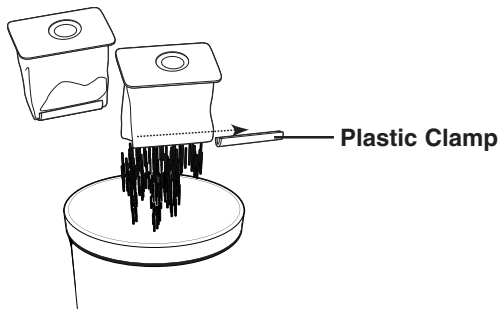

- 4 Check the motor filter and if necessary, clean. Reinstall the cloth bag and close bag cover.

How to Check and Clean Motor Filter

NOTE: Turn off vacuum and unplug the electrical cord before emptying cloth bag or cleaning motor filter. Never operate the vacuum cleaner without the cloth bag or filter.

- 1 Turn off and unplug cleaner.
- 2 Open bag cover by pushing latch and lifting lid.

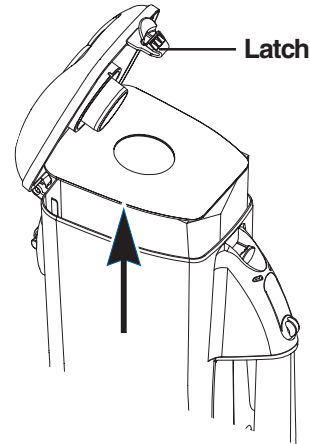

- 3 Remove cloth bag.
- 4 Remove the motor filter.

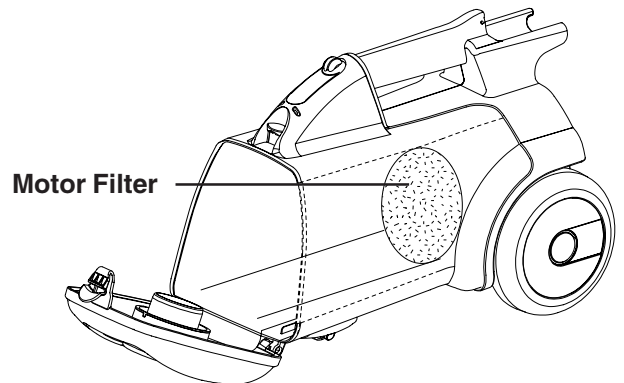

- 5 Clean motor filter by brushing over a waster container or by vacuuming with another vacuum.
- 6 If heavily soiled, clean by rinsing under warm water and let air dry
- 7 Replace bag in cleaner.
- 8 Swing bag cover closed and push to latch.

PROBLEM SOLVING

NOTE: Turn OFF the power switch and unplug the electrical cord before servicing.

PROBLEM	SOLUTION
Motor won't start.	<ul style="list-style-type: none"> • Push plug securely into outlet. • Try another outlet. • Check circuit breaker. • Make sure power switch is "ON".
No suction at end of hose.	<ul style="list-style-type: none"> • Replace bag. • Remove any clogs from hose that restrict air flow, then try again. • Check front cover and push until it latches firmly.
Reduced suction	<ul style="list-style-type: none"> • Replace bag. • Rotate slip ring on wand until hose is covered. • Remove any clogs from hose that restrict air flow, then try again.
Cleaner shuts off.	<ul style="list-style-type: none"> • Unplug cleaner and check for obstructions in hose, wands and attachments. • Check for full bag. • Clean/replace motor filter.
General questions.	<ul style="list-style-type: none"> • Call 1-800-282-2886 between 8 a.m. to 7:30 p.m. (CST) Monday - Friday and 10 a.m. to 6:30 p.m. Saturday. Know the model number and serial number when you call.

THE EUREKA LIMITED WARRANTY

What This Warranty Covers

Your Eureka cleaner is warranted to be free from all defects in material and workmanship in normal household use for a period of one year. The warranty is granted only to the original purchaser and members of his or her immediate household. The warranty is subject to the following provisions.

What This Warranty Does Not Cover

- Parts of the cleaner that require replacement under normal use, such as disposable dust bags, filters, drive belts, light bulbs, brush roll bristles, impellers and cleaning.
- Damages or malfunctions caused by negligence, abuse, or use not in accordance with the Owner's Guide.
- Defects or damages caused by unauthorized service or the use of other than Genuine Eureka parts.

What The Eureka Company Will Do

The Eureka Company will, at its option, repair or replace a defective cleaner or cleaner part that is covered by this warranty. As a matter of warranty policy, the Eureka Company will not refund the consumer's purchase price.

Warranty Registration

Please fill out and return the warranty registration card accompanying your cleaner.

Obtaining Warranty Service

To obtain warranty service you must return the defective cleaner or cleaner part along with proof of purchase to any Eureka Authorized Warranty Station. You will find the nearest location in the Yellow Pages, under "Vacuum Cleaners—Service and Repair." Be certain that the Warranty Station is "Eureka Authorized."

For the location of the nearest Eureka Authorized Warranty Station or for service information visit www.eureka.com, or telephone toll free: USA: 1-800-282-2886, Mexico: 5670-6169, Canada: 1-800-282-2886.

If you prefer, you can write to The Eureka Company, Service Division, 807 North Main Street, Bloomington, Illinois 61701, USA. In Canada write to The Eureka Company, 866 Langs Drive, Cambridge, Ontario N3H 2N7.

If it is necessary to ship the cleaner outside your community to obtain warranty repair, you must pay the shipping charges to the Eureka Authorized Warranty Station.

Return shipping charges will be paid by the Warranty Station. When returning parts for repair, please include the model, type, and serial number from the data plate on the cleaner.

Further Limitations and Exclusions

Any warranty that may be implied in connection with your purchase or use of the cleaner, including any warranty of Merchantability or any warranty for Fitness For A Particular Purpose is limited to the duration of this warranty. Some states do not allow limitations on how long an implied warranty lasts, so the above limitations may not apply to you.

Your relief for the breach of this warranty is limited to the relief expressly provided above. In no event shall Eureka be liable for any consequential or incidental damages you may incur in connection with your purchase or use of the cleaner. Some states do not allow the exclusion or limitation of incidental or consequential damages, so the above limitation or exclusion may not apply to you.

This warranty gives you specific legal rights. You may also have other rights which vary by state.

Questions & Answers about Genuine Eureka Products

Q: Why should I use only Genuine Eureka paper bags, belts, and parts in my Eureka vacuum cleaner?

A: Using Genuine Eureka Products, which are made to our exacting specifications and engineered with emphasis on quality, performance, and customer satisfaction, ensures the long life and cleaning efficiency of your vacuum cleaner.

Q: How can I be sure I am using only genuine Eureka products in my vacuum cleaner?

A: Typically, packaged products and paper bags are labeled "Genuine Eureka Product".

Q: Are there any differences between "made to fit" or "imitation" and Genuine Eureka paper bags, belts, and parts?

A: Yes, there are some very important differences in materials, quality, and reliability.

For Genuine Eureka Value, Accept No Imitations!

THE EUREKA COMPANY

Bloomington, Illinois 61701