

PermaLife®

Air Purifier

Owner's Manual

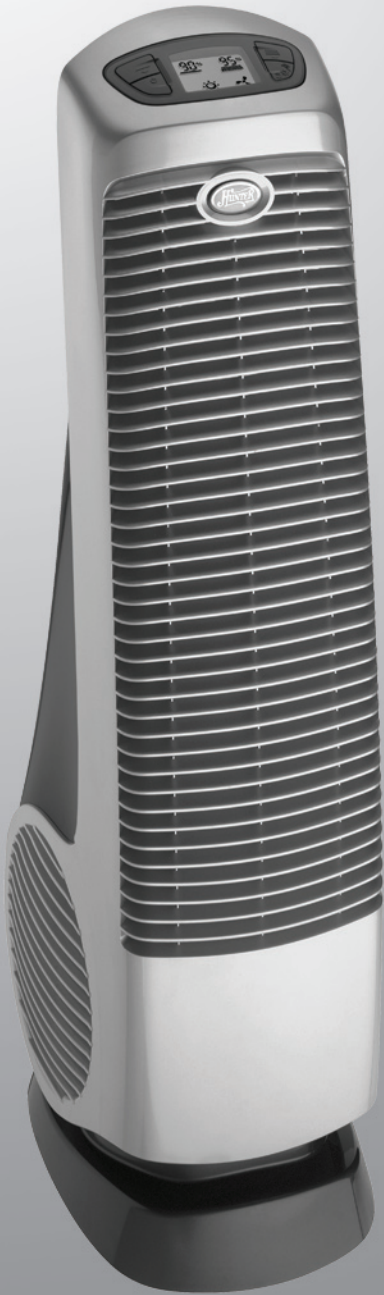

English

Model
30795

Form# 43086-01
20090305
©2009 Hunter Fan Co.

Hunter[®]
SINCE 1886



TABLE OF CONTENTS

| | |
|--------------------------------------|---|
| Introduction..... | 2 |
| Safety Instructions..... | 3 |
| Components..... | 3 |
| Using Your Air Purifier..... | 3 |
| How the PermaLife® System Works..... | 4 |
| Operating Your Air Purifier..... | 5 |
| Speed Descriptions..... | 5 |
| Lock/Unlock the Air Purifier..... | 5 |
| LCD Backlight On/Off..... | 5 |
| Filter Replacement..... | 6 |
| Cleaning..... | 6 |
| Cleaning the Carbon/Pre-Filters..... | 6 |
| Cleaning the PERMALife Filter..... | 6 |
| Resetting the Air Purifier..... | 8 |
| Technical Support..... | 8 |
| Troubleshooting..... | 8 |
| Filter Ordering..... | 8 |
| Warranty..... | 8 |

INTRODUCTION

Thank you for purchasing the PermaLife® Air Purification System from Hunter Fan Company. You have purchased our latest development in portable Air Purification Systems. This system has been developed to improve the quality of the air you breathe.

Our PermaLife® Air Purification System outperforms other air purification systems by quickly and effectively removing dust, smoke, and pollen particles as small as .5 microns in size. Room air is pulled in through the side grills and cleaned across the PermaLife™ filter. Clean air is then released out the front grill in order to avoid stirring up settled particles. The following innovative features are included in your Hunter Air Purifier.

- **High Particulate Efficiency:** The PermaLife® filter will remove 99.5% of particles as small as 0.5 micron particles from the air that passes through the filter.
- **Odor Removal:** The activated carbon pre-filter helps remove odors such as cooking, smoke, and pet smells from the air. It also traps lint, hair, and other large particles to help extend the life and performance of the PermaLife® filter.
- **Ionizer:** The ionizer improves the quality of air in the room by releasing negative ions into the air that attract positively charged dust, smoke, and pollen particles.
- **Filter Counter:** Filter maintenance is critical to the performance of the air purifier. To help you determine when to change the pre-filter and clean the PermaLife® filter, the unit has a built in Filter Counter that keeps track of the life remaining on each filter.
- **Remote Control:** This air purifier may also be controlled by the included remote. Using the remote, you can turn off the air purifier or change the speed to Sleep, Active, or Turbo Clean.



SAFETY INSTRUCTIONS

⚠ Save These Important Instructions

1. This Air Purifier is designed for use on a flat, level surface and may not work properly on an uneven surface. **ALWAYS** place this Air Purifier on a firm, level surface. **ALWAYS** place the Air Purifier at least six (6) inches away from walls and three (3) Ft. from heat sources such as stoves, radiators, or heaters.
2. Place the Air Purifier in an area that is out of the reach of children.
3. Before using the Air Purifier, extend the cord and inspect for any signs of damage. **DO NOT** use the product if the cord has been damaged.
4. To reduce the risk of electric shock, this product has a polarized plug (one blade is wider than the other) as a safety feature. This plug will fit into a polarized outlet only one way. If the plug does not fit fully into the outlet, reverse the plug. If it still does not fit, contact a qualified electrician. **DO NOT** attempt to defeat or override this safety feature.
5. **ALWAYS UNPLUG** the Air Purifier when it is not in operation, while the filter is being changed, and while it is being cleaned.
6. **DO NOT** tilt or move the Air Purifier while it is in operation. Shut off and unplug before moving.
7. **DO NOT** immerse the Air Purifier in water as permanent damage will occur. Refer to and follow the **CLEANING AND FILTER REPLACEMENT** instructions.
8. **DO NOT** run the ionizer if tobacco smoke, air fresheners, dripless wax candles, or grease from cooking is present.

COMPONENTS

Figure 1.

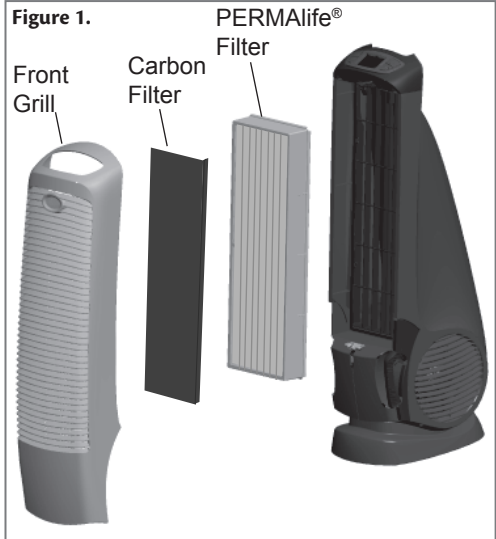
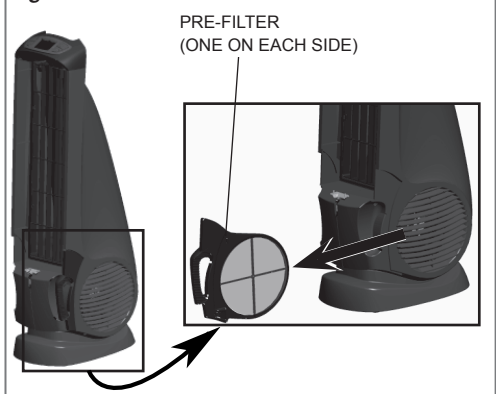

Figure 2.



USING YOUR AIR PURIFIER

1. Take the Air Purifier out of the box and remove the clear plastic protective bag. Place the unit on a firm level floor.
2. Before turning on the Air Purifier, you need to confirm that the PERMAlife® Filter is firmly in place and has not become loose during shipping. To check the filter, remove the front grill by placing your fingers under the grill release the handle and pulling the handle up. Refer to Figures 3 and 4.



Figure 3.

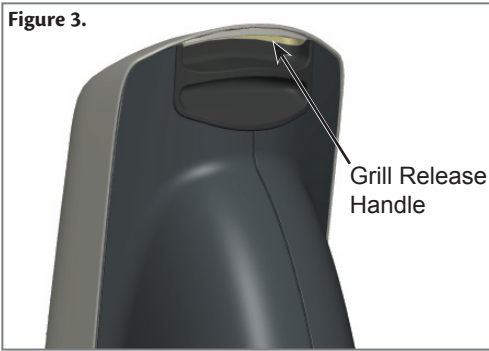
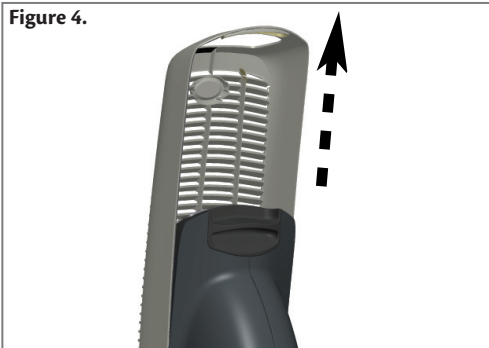
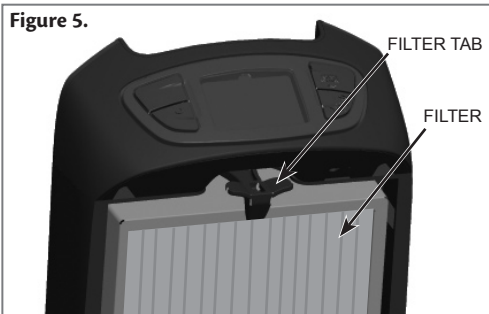

Figure 4.



3. Inspect the filter to ensure the bottom of the filter is secure and the top of the filter is behind the filter tab. Refer to Figure 5.

Figure 5.



4. If the filter is secure, place the front grill back onto the unit. Place the grill over the front of the Air Purifier and lower it into position. Refer to Figure 6.

NOTE: This unit will not operate unless the grill is in the correct position. If the filter is not secure, refer to the section Changing the PERMAlife Filter.

Figure 6.

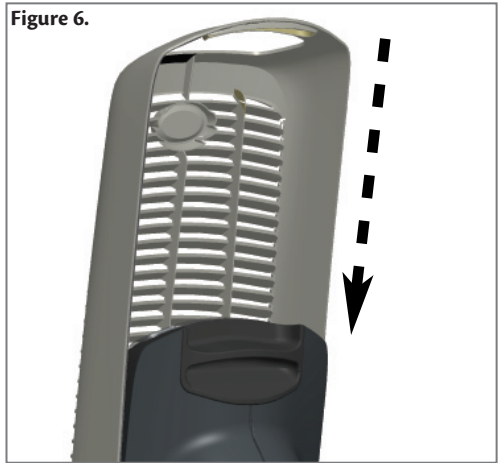

5. Plug the unit into a 120V electrical outlet

REMOTE OPERATION

For your convenience, a remote control is provided with this air purifier. The remote may be used to turn the air purifier on or off and adjust the fan speed. Operating the Air Purifier with the remote:

1. Install two AAA batteries (UM-4 or IEC R03 or equivalent). Refer to the graphics in the battery compartment for proper orientation of the batteries. (Figure 7.)

Figure 7.

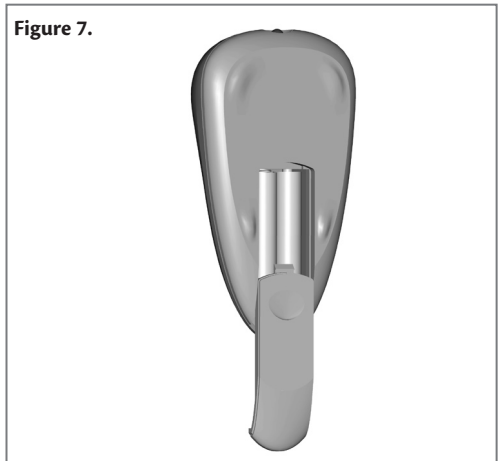

2. To use the remote, point it at the air purifier, then press and release the appropriate key. (Figure 8.) See "Speed Description" Section for Remote button Functions.



Figure 8.



If the remote is not working properly, first be sure that the remote is facing the air purifier when pressing the key. If it still does not work, check the batteries.

HOW THE PERMALIFE® SYSTEM WORKS

Dust and other irritants are pulled into the air purification system by the fan. The pre-filters on each side of the unit attracts larger particles like, pet dander, hair, and odor causing particles and traps them on the pre-filter. Smaller particles such as dust, mold, and pollen are captured by the PermaLife® filter. The pre-filter then captures any remaining particles and reduces odors before air is emitted back into the room. Up to 99.95% of particles as small as .5 microns can be captured. The ionizer charges any remaining particles causing them to clump together and fall to the floor or surface where they can be removed by cleaning. Clean, purified air is then released into the room through the side grill. (Figure 7.)

Figure 7.

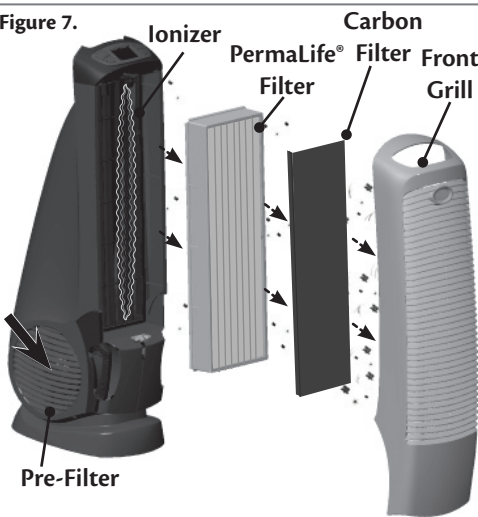

OPERATING YOUR AIR PURIFIER



FAN SPEED CONTROL: Sets the fan speed. Touch once for Low, again for Medium and once more for High speed. Press one last time to turn the unit off.



Pre-filters & CARBON odor FILTER Reset: Resets the Pre-Filter and Carbon Filter Life Counter.



PERMALife FILTER RESET: Resets the PERMALife Filter Life Counter.



IONIZER: Turns the ionizer on and off. NOTE: The ON / OFF key operates the ionizer ONLY.

Figure 8.

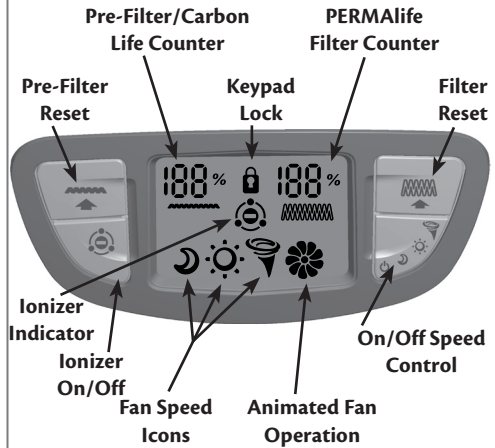

SPEED DESCRIPTIONS



Unit off

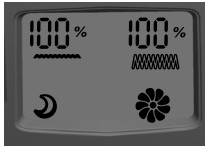

Low speed -
Recommended for use when soft background noise is unwanted.

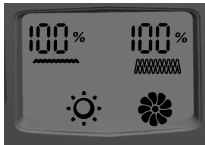

Medium speed -
Typical usage setting. Soft background noise is not an issue.

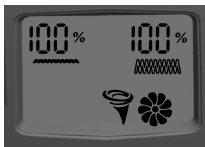

High speed -
Use when quick, efficient results to a room's air quality are desired.

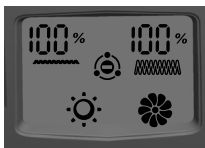

Ionizer on -
run the ionizer to assist the filters in cleaning the air.

LOCK/UNLOCK THE AIR PURIFIER

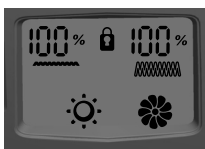

Once you enter the desired speed, you may want to lock the keypad to prevent accidental changing of the speed.

When the keypad is locked, all keys will be disabled. If you press a key, the Keypad Locked Indicator will be displayed on the screen for 1-2 seconds.



1. To lock the keypad, press and hold the PERMALife Filter Reset key and the Fan Speed Control key simultaneously for 2-3 seconds. The Keypad Locked Icon will appear on the display. After releasing

the keys, the Keypad Locked Icon will disappear.

2. To unlock the key pad, press and hold the PERMALife Filter Reset key and the Fan Speed Control key simultaneously for 2-3 seconds. The Keypad Locked Icon will disappear and the keypad will be functional.

LCD BACKLIGHT ON/OFF

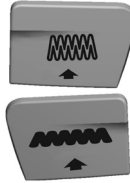

To turn on the LCD Backlight, press the Pre-Filter and the PERMALife Filter keys together. To turn the LCD Backlight off, repeat the process.

FILTER REPLACEMENT

The Pre-Filters, Carbon Odor Filter, and PERMALife Filter are critical to the proper operation of the Air Purifier. To help you know when to clean and change the filters, your Hunter Air Purifier has Filter Life Counters that will monitor the life of your filter. Although the exact life of the filters depends on the environment, the table below gives typical usage times of the filters.

| Filter Type | Typical Usage |
|--------------------------|---------------|
| PERMALife Filter | 2800 hours |
| Pre-Filter/Carbon Filter | 1400 hours |

The values of the Filter Life Counters are stored in the Air Purifier's memory. The unit may be unplugged and moved or stored without losing the Pre-Filter and Filter Counter values.

To properly track filter life, reset the Filter Life Counters each time the filters are changed or cleaned. Refer to "Cleaning the Carbon/Pre-Filters" or "Cleaning the PERMALife Filter" sections for instructions on how to reset the counters.

CLEANING

NOTE: To avoid the risk of electric shock, the unit should be unplugged before cleaning.

1. Clean the outside of the unit with a soft, damp cloth. The front grill can be cleaned in soapy water after it has been removed from the unit and the pre-filter has been removed. See Figure 1.

NOTE: Ensure the grill is completely dry before reinstalling it on the unit. Failure to do so could cause damage to the filters or motor.

CLEANING THE CARBON/PRE-FILTERS

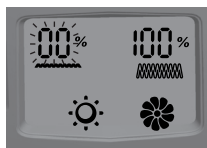

When the Pre-Filter exceeds 1400 hours, the Pre-Filter indicator will flash "00%" as a reminder that you should clean the Pre-Filter and

change the Carbon Odor Filter. To maintain proper odor-removing capability and overall filtration performance, the Pre-filters should be cleaned and the Carbon Odor filters replaced every 1400 hours (approximately 3 months of use). If necessary, clean the pre-filter and change the odor filter more often.

To clean the Pre-Filters, Change the Carbon Odor Filter, and reset the Pre-Filters & Carbon Odor Filter Life Counter:

1. First, turn off and unplug the Air Purifier.
2. Next, remove the front grill. Refer to Figs. 3 and 4.
3. Remove the Pre-Filters. Refer to Figure 2. Use a vacuum cleaner to remove dust from them. Then, reinsert the Pre-Filters into the Air Purifier.
4. The Carbon Odor Filter is held to the back of the Front Grill with four hook-and-pile fasteners. Peel off the old Carbon Odor Filter.
5. If needed, use a soft damp cloth to wipe off the Front Grill. Gently press a new filter into place.
6. Place the Front Grill back onto the unit.
7. Plug in the Air Purifier.
8. To reset the Pre-Filters & Carbon Odor Filter Life Counter to zero, press and hold the Pre-Filters & Carbon Odor Filter Reset Key for 3 seconds. When the display shows 100%, release the Key. The Counter is now reset.

CLEANING THE PERMALIFE FILTER

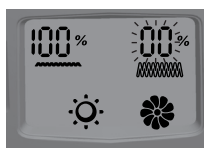

When the PERMALife Filter Life Counter reaches "00%" (approximately 6 months of use), you should check the filter to see if it

needs to be cleaned. The proper time to clean the filter depends on usage and the environment. Generally, if you notice a decrease in air output or an increase in noise at any time during normal operation, the filter may be clogged. Clean the filter to return to normal operation.

To clean the filter and reset the Filter Life Counter:

1. First, turn off and unplug the Air Purifier.
2. Next, remove the Front Grill. Place your fingers under the Grill Release Handle and pull up. Refer to Figures 10. and 11.

Figure 10.

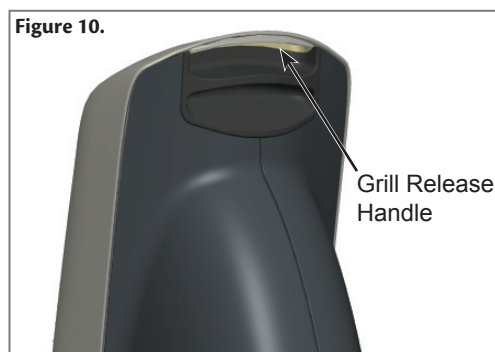
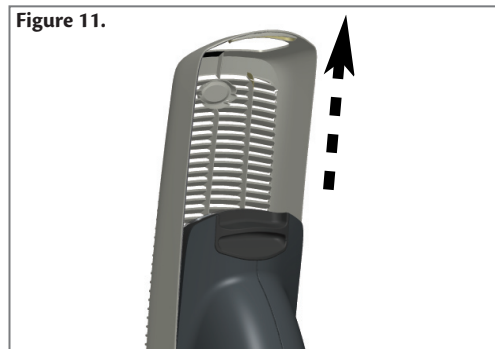

Figure 11.



3. Lift the Filter Tab and gently pull the filter out of the unit. Refer to Figure 11. While removing the filter, note the

filter's orientation, the cleaned filter will be installed in the same manner. Once removed, use a vacuum cleaner with an upholstery brush attachment, gently run the upholstery brush over the cleanable filter until all particles are removed from the filter.

Note: Filter discoloration is normal and will not be removed by vacuuming. Do not attempt to wash the filter as damage to the Filter or Air Purifier may occur.

Figure 12.

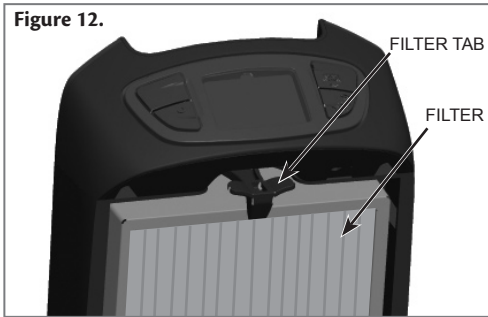

4. Place the bottom of the filter rim behind the ridges on each side of the bottom of the unit and snap into place. Refer to Figure 13.

Figure 13.

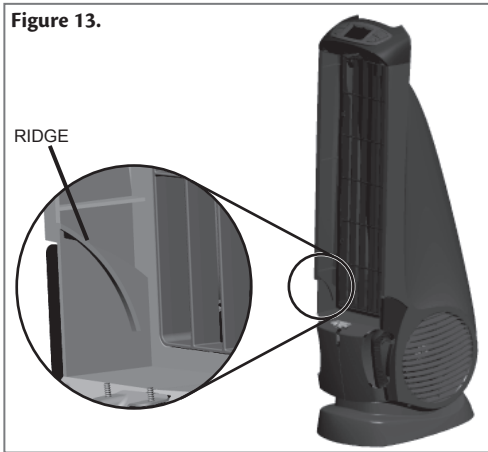

5. Place the grill over the front of the Air Purifier and lower it into position. Figure 14.

Figure 14.

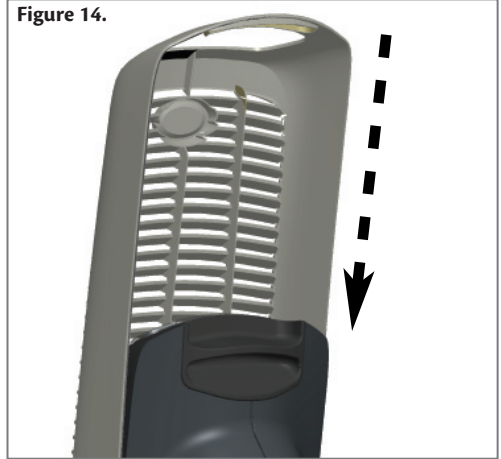

RESETTING THE AIR PURIFIER

In the unusual situation that the unit or the display is exhibiting erratic behavior, you may want to reset the Air Purifier. If you still have problems after resetting the Air Purifier, please contact Hunter for additional assistance.

To Reset the Air Purifier:

1. Unplug the unit for at least 30 seconds.
2. Plug the unit back in.

TECHNICAL SUPPORT

If you have any additional questions or problems with your Hunter Air Purifier, please call:

USA: 1-888-830-1326
Canada: 1-866-268-1936

Hours of operation are from 7:00 am to 7:00 pm Monday - Friday and 8:00 am to 5:00 pm on Saturday, Central Time. You may also contact us over the Internet at www.hunterfan.com.

TROUBLESHOOTING

Problem:
No Operation.

Solution:
Confirm that the unit is plugged in. Ensure the front grill is properly inserted. The unit will not run if the front grill is not in place properly.

Problem:
Unit has reduced air flow or increased noise.

Solution:
The filter may be clogged and needs to be cleaned. (page 5)

FILTER ORDERING

Your PermaLife® filter should never need to be replaced. Follow the cleaning instructions in this manual for care. Depending on usage and the environment, your Carbon Filter should be replaced every three months.

Replacement filters are available at most retailers that carry Hunter Air Purifiers. You may also purchase directly from Hunter Fan Company by:

Phone: 1-888-354-8375
Website: www.hunterfan.com

*Applicable state and local taxes may apply.

*Prices are subject to change without notice.

* All orders will be shipped USPS or UPS Ground, allow 12-15 working days for delivery.

| Filter# | Type | Price |
|---------|---------------|---------|
| 30901 | Carbon Filter | \$22.00 |

WARRANTY

Hunter Fan Company PERMALife® Air Purification System

5 YEAR LIMITED WARRANTY

The Hunter Fan Company makes the following limited warranty to the original residential user or consumer purchaser of the

PermaLife® Air Purification System:

If any part of your PermaLife® Air Purification System ("Air Purifier") motor fails during the first five (5) years from the date of installation due to a defect in material or workmanship, we will provide a replacement Air Purifier free of charge. Installation is deemed to occur at the date of purchase.

If the Air Purifier cord, ionizer, or front grill fails any time within one (1) year after installation due to a defect in material or workmanship, we will replace or, at our option, repair the unit free of charge at our nearest service center or at our Service Department in Memphis, Tennessee. You will be responsible for all parts and labor costs after this one-year period.

IF THE ORIGINAL RESIDENTIAL USER OR CONSUMER PURCHASER CEASES TO OWN THE AIR PURIFIER, THIS WARRANTY AND ANY IMPLIED WARRANTY WHICH THEN REMAINS IN EFFECT, INCLUDING BUT NOT LIMITED TO ANY IMPLIED WARRANTY OF MERCHANTABILITY OR FITNESS FOR A PARTICULAR PURPOSE, ARE VOIDED. NO WARRANTY, EXPRESSED OR IMPLIED, INCLUDING ANY WARRANTY OF MERCHANTABILITY OR FITNESS FOR A PARTICULAR PURPOSE, IS MADE IN RESPECT TO THE FILTER MATERIAL OR CARBON FILTER. THIS WARRANTY IS IN LIEU OF ALL OTHER EXPRESS WARRANTIES. THE DURATION OF ANY IMPLIED WARRANTY, INCLUDING BUT NOT LIMITED TO ANY IMPLIED WARRANTY OF MERCHANTABILITY OR FITNESS FOR A PARTICULAR PURPOSE, IN RESPECT TO THE MOTOR IS EXPRESSLY LIMITED TO THE PERIOD OF THE EXPRESS WARRANTY SET FORTH ABOVE.

This warranty is voided if the air purifier is not purchased and used in the USA or Canada.

This warranty excludes and does not cover defects, malfunctions or failures of the Air Purifier which were caused by repairs by persons not authorized by us, use of parts or accessories not authorized by us, mishandling, modifications, or damage to the Air Purifier while in your possession, or

unreasonable use, including failure to provide reasonable and necessary maintenance. This warranty does not cover Air Purifiers used in commercial applications. There are no express or implied warranties as to commercial purchasers or users.

To obtain service, contact the nearest Hunter authorized service center or the Hunter Fan Company Service Department, 2500 Frisco Avenue, Memphis, Tennessee 38114, 1-888-830-1326. For the name of our nearest authorized Hunter Fan Company Service Center, write to the Hunter Fan Company at the preceding address. You will be responsible for insurance and freight or other transportation to our factory service center. We will return the Air Purifier freight prepaid. The Air Purifier should be properly packaged to avoid damage in transit since we will not be responsible for any such damage. Proof of purchase is required when requesting warranty service. The purchaser must present sales receipt or other document that establishes proof of purchase.

IN NO EVENT SHALL HUNTER FAN COMPANY BE LIABLE FOR DIRECT, INDIRECT, SPECIAL CONSEQUENTIAL OR INCIDENTAL DAMAGES IN EXCESS OF THE PURCHASE PRICE OF THE AIR PURIFIER. YOUR SOLE REMEDY WILL BE REPAIR OR REPLACEMENT AS PROVIDED ABOVE. SOME AMERICAN STATES AND CANADIAN PROVINCES DO NOT ALLOW LIMITATIONS ON HOW LONG AN IMPLIED WARRANTY LASTS, SO THE ABOVE LIMITATION MAY NOT APPLY TO YOU.

SOME AMERICAN STATES AND CANADIAN PROVINCES DO NOT ALLOW THE EXCLUSION OR LIMITATION OF DIRECT, INDIRECT SPECIAL, INCIDENTAL OR CONSEQUENTIAL DAMAGES, SO THE ABOVE LIMITATION MAY NOT APPLY TO YOU. SOME AMERICAN STATES AND CANADIAN PROVINCES DO NOT ALLOW THE EXCLUSION OR INVALIDITY OF EXPRESS OR IMPLIED WARRANTIES IF THE USER CEASES TO OWN THE AIR PURIFIER, SO THE ABOVE LIMITATION MAY NOT APPLY TO YOU.

THIS WARRANTY GIVES YOU SPECIFIC LEGAL RIGHTS, AND YOU MAY ALSO HAVE OTHER RIGHTS WHICH VARY FROM STATE TO STATE OR PROVINCE TO PROVINCE.

Other Hunter Products

Oscillating Fans

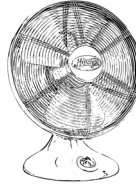

Ceiling Fans



Humidifiers



Air Purifiers

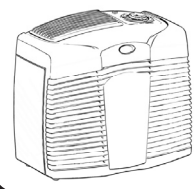

Bath Fans

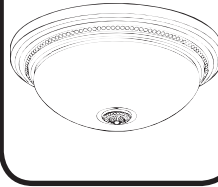

Thermostats



To learn more about Hunter Fan Company products, please see our Web page at:

www.hunterfan.com

Hunter Fan Company
7130 Goodlett Farms Pkwy. Suite 400
Memphis, Tennessee 38114

Printed in China and Taiwan