



# RF-Link™

**Model: DAV-2450**  
**2.4GHz Digital Wireless A/V sender**

## User's Manual



### Contents

- 1. Important Safety Information.....1
- 2. Package Content.....2
- 3. Panel Control And Function.....3
- 4. Setup Guide.....4
- 5. Troubleshooting.....5

### 1. Important Safety Information

To prevent fire or shock hazard, do not expose this product to rain and moisture. For example: do not use near a bathtub, washbowl, kitchen sink, or laundry tub, in a wet basement, or nearby a swimming pool. To avoid electric shock, do not take apart this product, provided as an accessory. This product should be operated only under power supply. Do not overload wall outlets and extension outlets as this can result in the risk of fire or electric shock.

### 2. Package Contents

Check to make sure that all units shown as below are enclosed. If something missed, please contact your dealer.

- 1. 2.4GHz Transmitter x 1 
- 2. 2.4GHz Receiver x 1 
- 3. Antenna x 2 
- 4. BNC to RCA adapter x 6 
- 4. Power Adapters (9V/500mA) x 2 

### 3. Panel Control and Function

Transmitter/Receiver

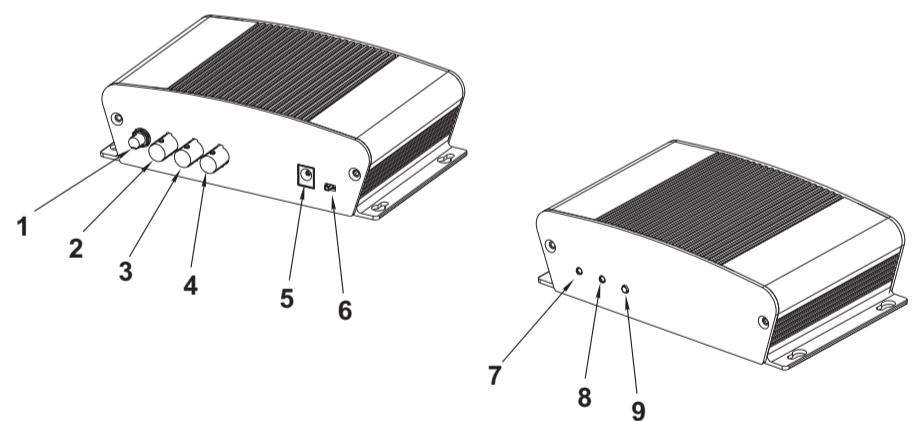

- 1. SMA-F/F to Connect to Antenna
- 2. Audio Jack (BNC type), Left Channel
- 3. Audio Jack (BNC type), Right Channel
- 4. Video Jack (BNC type)
- 5. Power Adapter Jack
- 6. Power ON/OFF Switch
- 7. LED Indicator: Power Indicator
- 8. LED Indicator: Link Indicator
- 9. Tact Switch for Pairing

## 4. Setup Guide

Note: Make sure the ON/OFF switch is in the 「OFF」 position before connection

### Transmitter

1. Connect one end of the BNC cable to the audio and video jacks, and connect the other end to your source device. (Or BNC-to-RCA adapter to audio and video jacks first, then connect RCA cable between transmitter and source device)
2. Connect antenna to transmitter.
3. Connect power adapter to transmitter, then plug in power to an outlet.
4. Turn on power on transmitter.

### Receiver

1. Connect one end of the BNC cable to the audio and video jacks, and connect the other end to your receiving device. (Or BNC-to-RCA adapter to audio and video jacks first, then connect RCA cable between receiver and receiving devices, such as monitor, speaker....)
2. Connect antenna to receiver.
3. Connect power adapter to receiver, then plug in power to an outlet.
4. Turn on power on receiver.

### Pairing Process

Press the "Pairing" button after both transmitter and receiver are power on, the "Link" light will flash (it means the transmitter is searching the receiver). The "Link" light become solid when the pairing process is done and success.

#### Note:

- Once the first pairing process is successful, there is no need to repeat it in the future.
- If the "Link" light is off after pairing process is successful, it normally mean there is no connection between transmitter and receiver. Most of cases it is because the transmission is out of the range, and the signal reception is not stable. Please adjust the distance between transmitter and receiver until it works.

4

## 5. Troubleshooting

If there is no signal at all

- Check cable connections from the transmitter to the source device, and the receiver to the receiving device.
- Make sure power of all devices are on.
- Switch all power off and on again to ensure everything is functioning well.

If the signal is poor, or there is an interference

- Change transmitter's location.
- Double check if there is a microwave oven in use, and if it is in the path between transmitter and receiver. If yes, please either remove it or turn it off.
- Make sure the transmission is within its operating range (up to 300 meters with clear line of sight).

## Care and Maintenance

- Keep all parts and accessories out the reach of young children.
- Do not attempt to open the case.
- Keep dry. Precipitation, humidity, and liquids contain minerals that will corrode electronic circuits.
- Do not use or store the unit in dusty, dirty areas.
- Do not store the unit in high temperature area. It can shorten the life of electronic components, and warp or melt certain plastic parts.
- Do not store the unit in cold temperature area. When the unit warms up (to its normal temperature), moisture can form inside the case, which may cause damage to electronic circuit boards.
- Do not drop, knock, or shake the unit. Rough handling can break internal circuit boards.
- Do not use chemicals, cleaning solvents, or strong detergents when cleaning.
- Only use the power adapter included in the package to operate the unit.
- Try not overload electrical outlets or extension cords as this can result in fire or electric shock.

5

## FCC Statement



This device complies with part 15 of the FCC rules. Operation is subject to the following two conditions: (1) this device may not cause harmful interference, and (2) this device must accept any interference received, including interference that may cause undesired operation.

#### Note:

This equipment has been tested and found to comply with the limits regulated by FCC and CE. These limits are designed to provide reasonable protection against harmful interference in a residential installation. This equipment generates, uses and can radiate radio frequency energy and, if not installed and used in accordance with the instruction, may cause harmful interference to radio communications. The change or modifications not expressly approved by the party responsible for compliance could void the user's authority to operate the equipment. To comply with the FCC RF exposure compliance requirements, no change to the antenna or the device is permitted. Any change to the antenna or the device could result in the device exceeding the RF exposure requirements and void user's authority to operate the device.

## WEEE Directive & Product Disposal



At the end of its serviceable life, this product should not be treated as household or general waste. It should be handed over to the applicable collection point for the recycling of electrical and electronic equipment, or returned to the supplier for disposal.

6



TTD-B2450T  
TTD-B2450R

408-000666-00