

755c, 785c² and 785c²i Chartplotter Operations Manual

531542-1_A



 **HUMMINBIRD**

700 series™

Thank You!

Thank you for choosing Humminbird®, America's #1 name in fishfinders. Humminbird® has built its reputation by designing and manufacturing top-quality, thoroughly reliable marine equipment. Your Humminbird® is designed for trouble-free use in even the harshest marine environment. In the unlikely event that your Humminbird® does require repairs, we offer an exclusive Service Policy - free of charge during the first year after purchase, and available at a reasonable rate after the one-year period. For complete details, see the separate warranty card included with your unit. We encourage you to read this operations manual carefully in order to get full benefit from all the features and applications of your Humminbird® product.

Contact our Customer Resource Center at either **1-800-633-1468** or visit our website at **www.humminbird.com**.

***WARNING!** This device should not be used as a navigational aid to prevent collision, grounding, boat damage, or personal injury. When the boat is moving, water depth may change too quickly to allow time for you to react. Always operate the boat at very slow speeds if you suspect shallow water or submerged objects.*

***WARNING!** Disassembly and repair of this electronic unit should only be performed by authorized service personnel. Any modification of the serial number or attempt to repair the original equipment or accessories by unauthorized individuals will void the warranty. Handling and/or opening this unit may result in exposure to lead, in the form of solder.*

***WARNING!** This product contains lead, a chemical known to the state of California to cause cancer, birth defects and other reproductive harm.*

***NOTE:** Some features discussed in this manual require a separate purchase, and some features are only available on international models. Every effort has been made to clearly identify those features. Please read the manual carefully in order to understand the full capabilities of your model.*

CannonLink™, Fishing GPS®, Humminbird®, HumminbirdPC™, InterLink™, WeatherSense®, and X-Press™ Menu are trademarked by or registered trademarks of Humminbird®.

© 2006 Humminbird®, Eufaula AL, USA. All rights reserved.

Table of Contents

How GPS and Cartography Work	1
Multi-Media Card (MMC)/SD Slot	3
Software Updates	3
What's On the Display	4
Views	6
Bird's Eye Views	7
Chart Views	10
Instrument View.....	13
Screen Snapshot View.....	14
View Orientation	16
Viewing Cartography	17
Introduction to Navigation	19
Waypoints, Routes and Tracks	20
Save, Edit or Delete a Waypoint	21
Navigate to a Waypoint or Position	22
Add a Waypoint Target or Trolling Grid	23
Save, Edit or Delete a Route	25
Save or Clear a Current Track	26
Edit, Delete or Hide Saved Tracks	26
Man Overboard (MOB) Navigation	27

Table of Contents

Key Functions	29
POWER/LIGHT Key	29
VIEW Key	29
INFO Key.....	30
MENU Key	30
4-WAY Cursor Control Key	31
MARK Key	31
GOTO Key	31
ZOOM (+/-) Key	32
EXIT Key	32
Accessory Bus	33
Powering Up the Unit	34
The Menu System	35
Start-Up Options Menu	38
Normal Operation.....	38
Simulator	39
System Status	40
Self Test	40
Accessory Test	41
GPS Diagnostic View	42
PC Connect (<i>with PC Connect cable only</i>)	43

Table of Contents

Navigation X-Press™ Menu <i>(Navigation views only)</i>	44
Waypoint [Name] <i>(only with an active cursor on a waypoint)</i>	45
Cursor To Waypoint <i>(Chart Views only)</i>	46
Save Current Track	46
Clear Current Track	47
Save Current Route <i>(only when navigating)</i>	47
Skip Next Waypoint <i>(only when navigating)</i>	48
Cancel Navigation <i>(only when navigating)</i>	48
Cancel MOB Navigation <i>(only when MOB Navigation is activated)</i>	49
Remove Target <i>(only if Target is Active)</i>	49
Remove Grid <i>(only if Grid is Active)</i>	50
Waypoint [Name] <i>(Most recently-created waypoint)</i>	50
Select Readouts	52
Screen Snapshot X-Press™ Menu <i>(Screen Snapshot View only)</i>	60
Delete Image <i>(optional-purchase MMC/SD card only)</i>	61
Delete All Images <i>(optional-purchase MMC/SD card only)</i>	61
Navigation Menu Tab	62
Current Track	63
Saved Tracks	64
Waypoints	65
Routes	66
Chart Orientation	67
North Reference	67
Grid Rotation	67
Trackpoint Interval	68
Track Min. Distance <i>(Advanced)</i>	68
Track Color Range	69

Table of Contents

Map Datum (<i>Advanced</i>)	69
Course Projection Line	70
Export All Nav Data (<i>Advanced</i>)	70
Delete All Nav Data (<i>Advanced</i>)	71
Continuous Navigation Mode	71

Chart Menu Tab **72**

Chart Detail Level	73
Map Borders	74
Lat/Lon Grid	75
Spot Soundings	75
Nav aids on Bird's Eye View	75
Shaded Depth	76
Set Simulation Position (<i>Advanced</i>)	76
Set Map Offset (<i>Advanced</i>)	77
Clear Map Offset (<i>Advanced</i>)	77

Alarms Menu Tab **78**

Low Battery Alarm	79
Aux. Temp. Alarm (<i>with optional-purchase temp. probe or Temp/Speed only</i>) ..	79
Temp. Alarm	80
Off Course Alarm	80
Arrival Alarm	81
Drift Alarm	82
Alarm Tone	83

Table of Contents

Setup Menu Tab	84
Units - Depth	85
Units - Temp. (<i>International only</i>)	85
Units - Distance	85
Units - Speed	86
User Mode	86
Language (<i>International only</i>)	86
Triplog Reset	87
Restore Defaults.....	87
Aux. Temp. Offset (<i>Advanced</i>).....	88
Temp. Offset (<i>Advanced</i>)	88
Speed Calibration (<i>Advanced, with Temp/Speed only</i>).....	89
Local Time Zone (<i>Advanced</i>)	89
Daylight Saving Time (<i>Advanced</i>)	90
Position Format (<i>Advanced</i>)	90
Time Format (<i>Advanced, International only</i>)	91
Date Format (<i>Advanced, International only</i>)	91
Digits Format (<i>Advanced</i>)	92
NMEA Output (<i>Advanced</i>)	92
Demonstration	93
Views Menu Tab	94
Accessories Menu Tab	95
Using Screen Snapshot	96

Table of Contents

Troubleshooting	98
Chartplotter Doesn't Power Up	98
Display Problems	99
Finding the Cause of Noise	99
700 Series™ Chartplotter Accessories	100
Specifications	102
Glossary	103
Contact Humminbird®	112

NOTE: Entries in this Table of Contents which list (International only) are only available on products sold outside of the U.S. by our authorized International Distributors. To obtain a list of authorized International Distributors, please visit our website at www.humminbird.com or contact our Customer Resource Center at **1-800-633-1468** to locate the distributor nearest you.

NOTE: Entries in this Table of Contents which list (with PC Connect Cable only) or (with Temp/Speed only) require the purchase of separate accessories. You can visit our website at www.humminbird.com to order these accessories online or contact our Customer Resource Center at **1-800-633-1468**.

How GPS and Cartography Work

Your 700 Series™ Chartplotter supports GPS and chartplotting, and uses GPS to determine your position and display it on a grid. The Global Positioning System (GPS) is a satellite navigation system designed and maintained by the U.S. Department of Defense. GPS was originally intended for military use; however, civilians may also take advantage of its highly accurate position capabilities, typically within +/- 10 meters, depending on conditions. This means that 95% of the time, the GPS receiver will read a location within 10 meters of your actual position. Your GPS Receiver also uses information from WAAS (the Wide Area Augmentation System), EGNOS (the European Geostationary Navigation Overlay Service), and MSAS (the MTSAT Satellite Augmentation System) satellites if they are available in your area.



GPS uses a constellation of 24 satellites that continually send radio signals to the earth. Your present position is determined by receiving signals from up to 16 satellites and measuring the distance from the satellites.

All satellites broadcast a uniquely coded signal once per second at exactly the same time. The GPS receiver on your boat receives signals from satellites that are visible to it. Based on time differences between each received signal, the GPS receiver determines its distance to each satellite. With distances known, the GPS receiver mathematically triangulates its own position. With once per second updates, the GPS receiver then calculates its velocity and bearing.

The following GPS functionality is currently supported by the 700 Series™ Chartplotter when it is connected to the included GPS receiver:

- View current position
- View current track (breadcrumb trail)
- View precision speed and heading from your GPS receiver
- Save tracks, waypoints and routes
- Travel a route and navigate from one waypoint to the next.

Your 700 Series™ supports Navionics® Gold, HotMaps™ and HotMaps™ Premium on MMC or SD card media.

***NOTE:** Your 700 Series™ does not support Navionics® Classic Charts, only Navionics® Gold, HotMaps™, and HotMaps™ Premium.*

Your unit also comes with a built-in UniMap™ with a more detailed map of North America (Domestic models) or a more detailed map of Europe and Southeast Asia, including Australia and New Zealand (International models).

Your 700 Series™ uses the GPS Receiver to determine the position of the boat automatically, and uses the zoom level settings on a particular view to select the best chart to display. See *Viewing Cartography* for more information.

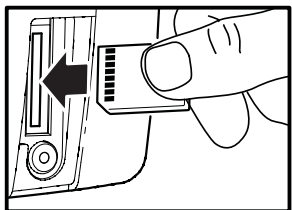

Inserting an MMC/SD
into the Card Slot

Multi-Media Card (MMC)/SD Slot

Your 700 Series™ Chartplotter also has a multi-media card (MMC)/SD slot that is used to insert optional-purchase cards containing additional detailed maps. If you insert an MMC/SD that contains a more detailed chart for a particular location, your 700 Series™ Chartplotter will retrieve that chart and display it automatically.

Use the illustration to locate the position of the MMC/SD slot cover, remove the MMC/SD slot cover, then insert the MMC/SD into the slot. The label on the MMC/SD should face toward the right side of the unit. Press down on the card until it clicks into place, then replace the slot cover, making certain that the gasket is present and positioned correctly before re-installing the cover, then replace and tighten snugly - do NOT overtighten, as this will not improve water resistance, and may damage the cover.

Software Updates

Use the MMC/SD slot to update the software version of your control head. To update the software in your control head, plug in the appropriate MMC/SD card that contains a software update file; the unit will recognize it, will tell you what software version your control head is currently running, and will ask you if you want to update the software in the unit to match that on the MMC/SD card. You can obtain software updates from the www.humminbird.com website.

What's On the Display

The 700 Series™ Chartplotter can display a variety of useful information.

Latitude and Longitude Position of Cursor

Cursor Info Box: indicates the Latitude and Longitude of the cursor position, the distance to travel to the cursor position and the bearing to the cursor position is shown with a GPS receiver. A waypoint can be marked at the cursor position for later retrieval and use with a GPS receiver.

Boat Icon

Route: Two or more linked waypoints that show intended navigation and the shortest path from one waypoint to the next.

Track: Detailed position history, displayed as a breadcrumb trail of trackpoints.

Map Scale

Cartography

NEXT: Next Waypoint in the Route

TTG: Time to Go to Waypoint

DTG: Distance to Go to Waypoint

Speed Over Ground: the measurement of the boat's progress across a given distance, and is the speed measurement provided by GPS.

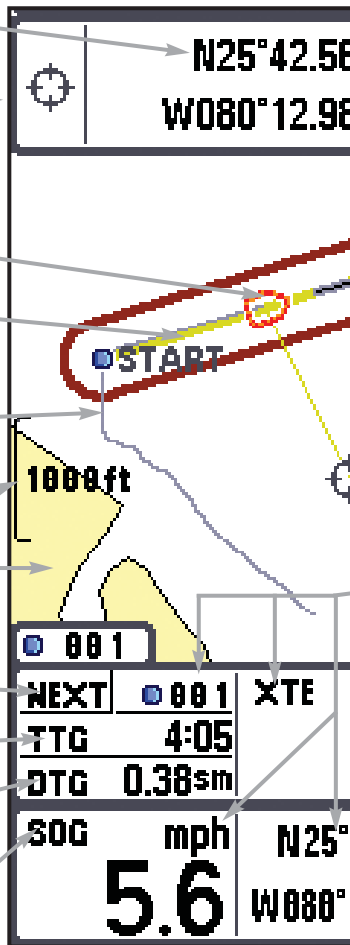

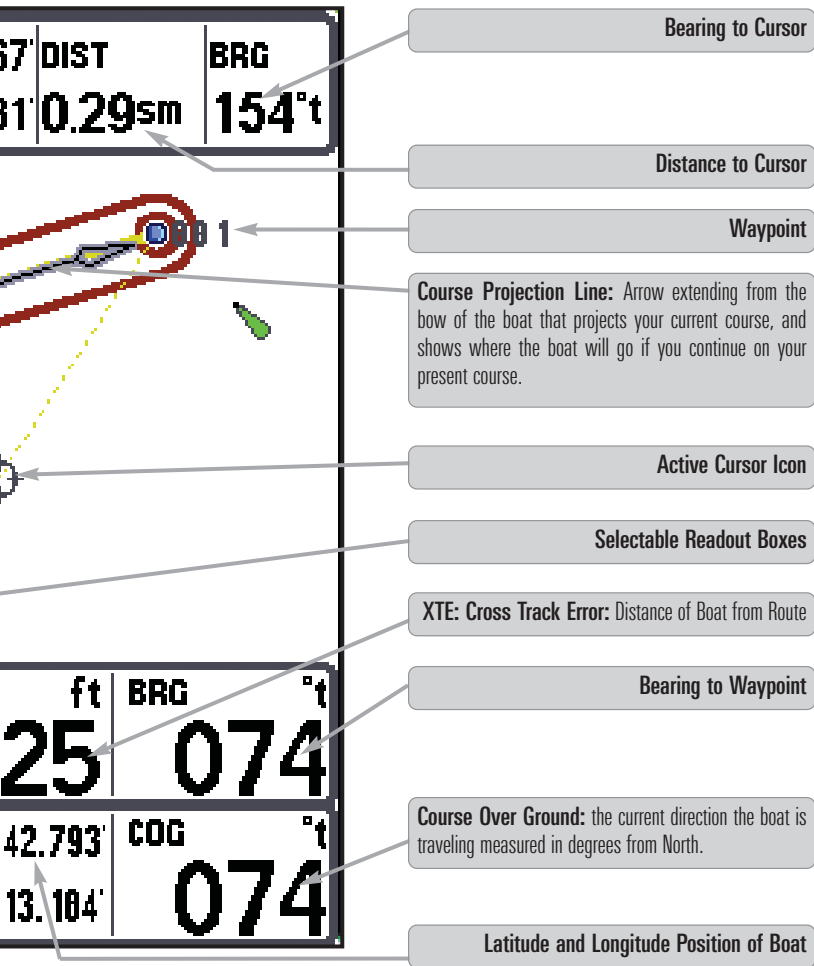

Bearing to Cursor

Distance to Cursor

Waypoint

Course Projection Line: Arrow extending from the bow of the boat that projects your current course, and shows where the boat will go if you continue on your present course.

Active Cursor Icon

Selectable Readout Boxes

XTE: Cross Track Error: Distance of Boat from Route

Bearing to Waypoint

Course Over Ground: the current direction the boat is traveling measured in degrees from North.

Latitude and Longitude Position of Boat

Views

The views available on your Chartplotter are:

- Bird's Eye No Readouts View
- Bird's Eye View
- Bird's Eye Big Digits View
- Chart No Readouts View
- Chart View
- Chart Big Digits View
- Instrument View
- Screen Snapshot View
- GPS Diagnostic View.

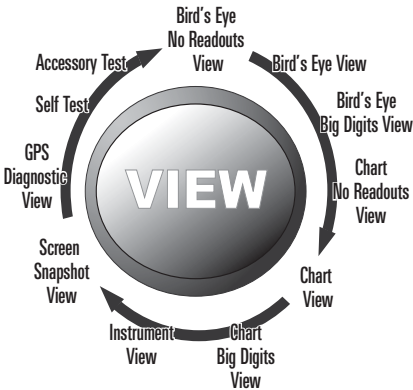

***NOTE:** When you change any menu settings that affect the display, the view will update immediately (i.e. you don't have to exit the menu to apply the change to the screen).*

GPS Diagnostic View is the default view until GPS communications are established. At that point, all the other views become available. When the VIEW key is pressed, the display cycles through the available views. When the EXIT key is pressed, the display cycles through the available views in reverse order. Any view can be hidden or displayed as part of the view rotation using the Views Menu tab. See *Start-Up Options Menu* for information about the Self Test, Accessory Test, and GPS Diagnostic Views.

Bird's Eye Views

Bird's Eye Views - The Standard Bird's Eye, Bird's Eye Big Digits, and Bird's Eye No Readouts Views show a 3-D, perspective view of the track and the chart's land contour from a point above and behind the boat (the eye point). As the boat turns, the eye point moves to follow the boat.

When you press the 4-WAY Cursor key in the **Bird's Eye View**, the position of the eye point will shift. This allows you to move and turn the eye point so that you can look off to the sides, or even behind the boat. Pressing the RIGHT or LEFT arrow keys on the 4-WAY Cursor key turns the eye point right or left, while pressing the UP arrow key moves the eye point forward, and pressing the DOWN arrow key moves the eye point backward.

Pressing the EXIT key moves the eye point back to its original position behind and above the boat.

NOTE: Standard Bird's Eye View and Chart View share the same set of 9 readouts, 7 of which are adjustable. When you change the readouts display on the Bird's Eye View, you also are changing them on the Chart View.

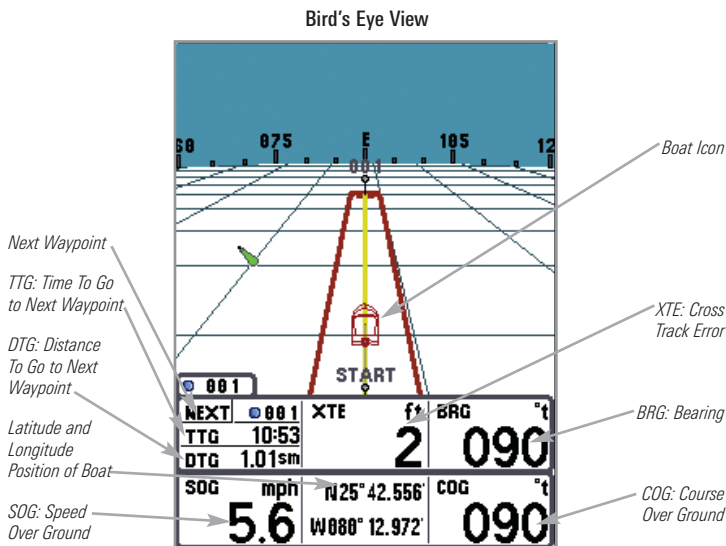

You may also choose **Bird's Eye Big Digits View** or **Bird's Eye No Readouts View** if you prefer.

NOTE: *Bird's Eye Big Digits View, Chart Big Digits View, and Instrument View all share the same set of 8 readouts. When you change the readouts display on one of these three views, you are also changing them on the other two views. See **Navigation X-Press™ menu: Select Readouts** for more information.*

Bird's Eye Big Digits View

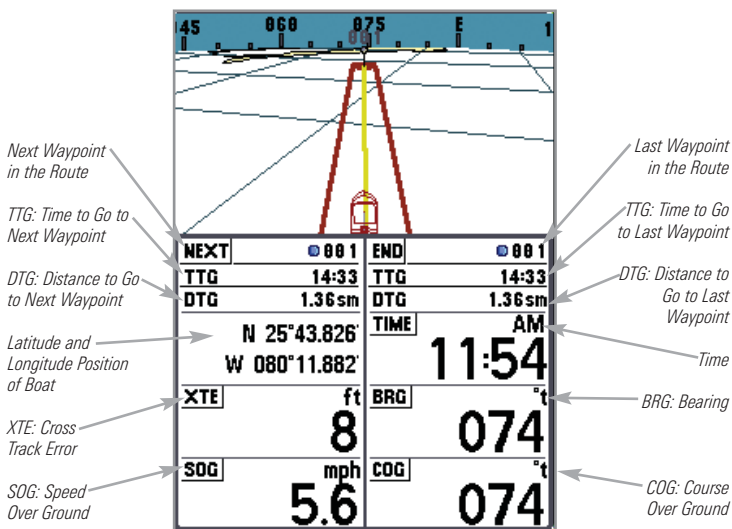

Bird's Eye No Readouts View

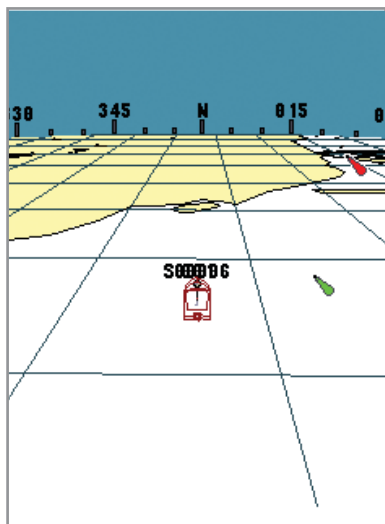

Chart Views

Chart Views - The standard Chart, Chart Big Digits, and Chart No Readouts Views show cartography from the built-in UniMap™ or an optional MMC/SD map for the area surrounding your current position. The current track (also known as the position history or breadcrumb trail) showing where the boat has been, along with saved tracks, waypoints, and the current route (when navigating), are overlaid on the chart. You can use the 4-WAY Cursor Control key to shift/pan the chart to another area. You can use the ZOOM (+/-) keys to zoom in and out. You can use the INFO key to get information on the chart objects near the cursor.

NOTE: Standard Bird's Eye View and Chart View share the same set of 9 readouts, 7 of which are adjustable. When you change the readouts display on the Bird's Eye View, you also are changing them on the Chart View.

NOTE: Bird's Eye Big Digits View, Chart Big Digits View, and Instrument View all share the same set of 8 readouts. When you change the readouts display on one of these three views, you are also changing them on the other two views. See **Navigation X-Press™ menu: Select Readouts** for more information.

Chart View without Active Cursor, shown with
Optional-Purchase Navionics® Cartography

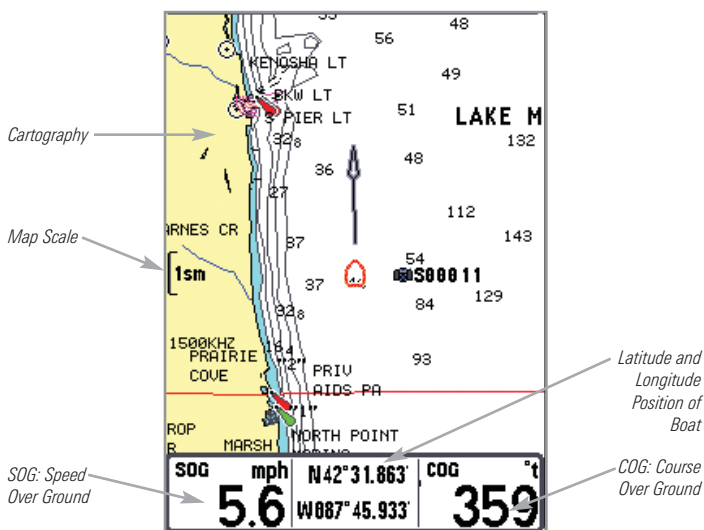

Chart View with Active Cursor, shown
with Optional-Purchase Navionics® Cartography

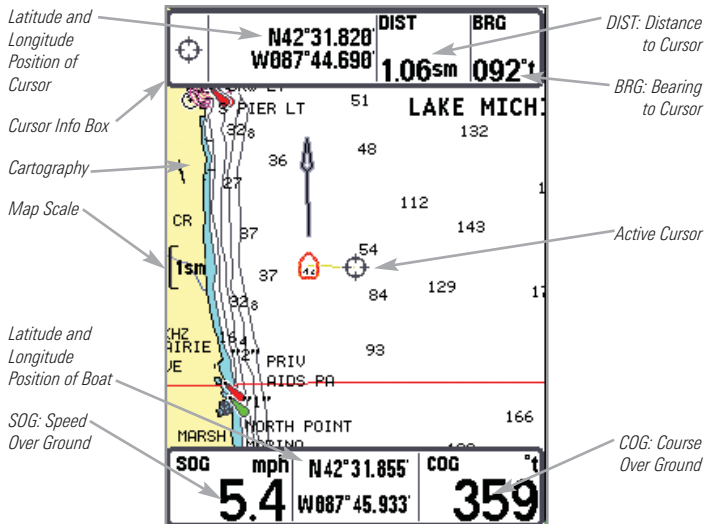
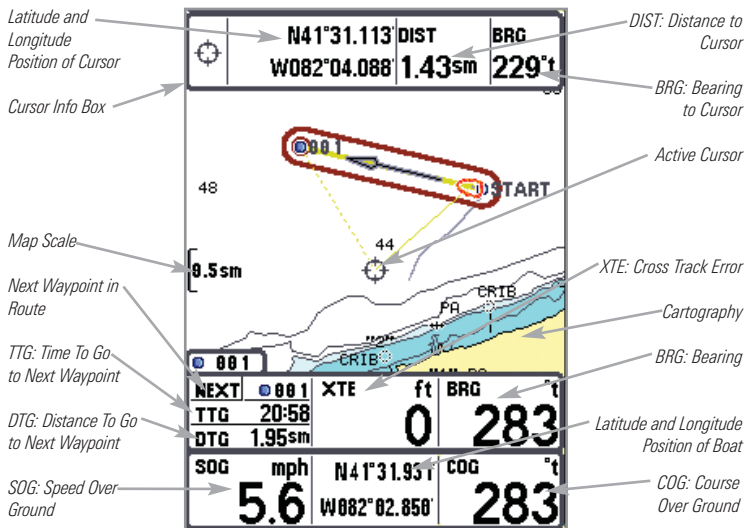

Chart View with Active Cursor, with Optional-Purchase Navionics® Cartography, Showing Navigation



You may also choose **Chart Big Digits View** or **Chart No Readouts View** if you prefer.

Chart Big Digits View

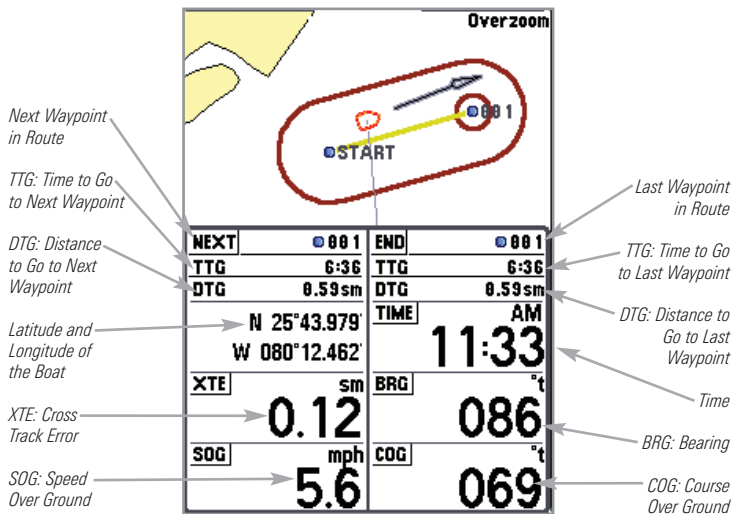

Chart No Readouts View



Instrument View

Instrument View allows you to display a digital instrument panel with 8 selectable readouts. This view provides a digital compass at the top of the view, as well as 8 selectable readouts, and a Cross Track Error (XTE) graphic at the bottom of the view. The XTE graphic shows the boat's position in relation to the Off Course Alarm limits, as well as the optimal route (shown as the dotted line in the middle). You should try to keep the boat as close to the dotted line as possible for best results. If your course exceeds the Off Course Alarm limits, an alarm will sound, and the boat icon will change position and will turn from black to red to indicate the alarm state.

NOTE: *Bird's Eye Big Digits View, Chart Big Digits View, and Instrument View all share the same set of 8 readouts. When you change the readouts display on one of these three views, you are also changing them on the other two views. See **Navigation X-Press™ menu: Select Readouts** for more information.*

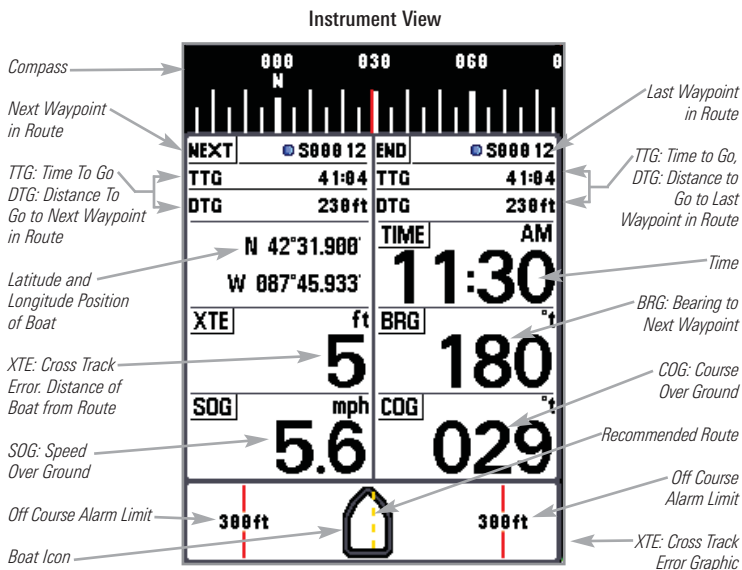

NOTE: *If there is only one waypoint in a route, the Next Waypoint and the End Waypoint info boxes will display the same information, both for that next waypoint.*

Screen Snapshot View

Screen Snapshot View displays and allows you to view screen snapshot thumbnails captured to an optional-purchase MMC/SD card installed in your unit. In addition, when you are in the Screen Snapshot View, Delete Image and Delete All Images are added to the X-Press™ menu.

The Screen Snapshot View displays up to three screen snapshot thumbnails on the screen at a time; you may have to scroll using the 4-WAY Cursor keys to see the whole list of thumbnails in this view. The selected thumbnail will be highlighted with arrows.

NOTE: The speed of the screen capture depends on the type of card you use; in general, SD cards capture the screen faster than MMC cards do.

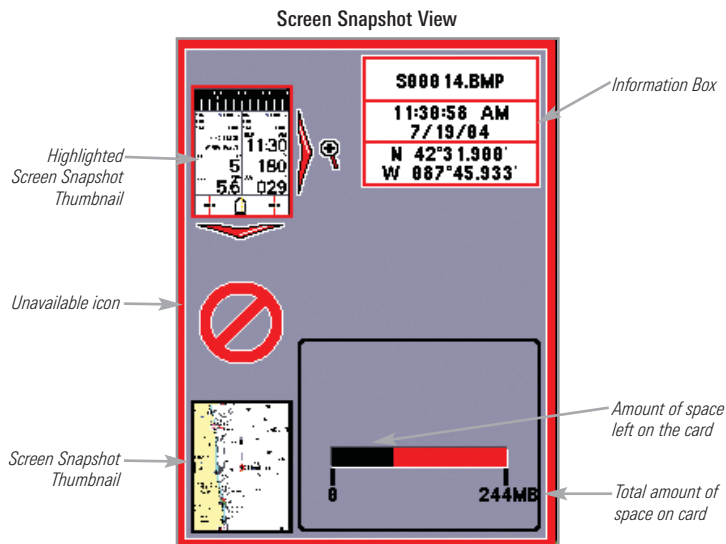

Screen Snapshot: When Screen Snapshot is enabled (from the Accessories menu tab), pressing the MARK key creates a saved screen capture (when you have an optional-purchase MMC/SD card installed). Once you have created a screen capture, a screen capture thumbnail is added to the Screen Snapshot View, and is available to view at a later date. See the full-sized image by highlighting a thumbnail (using the Up or Down 4-Way Cursor keys), then using the Right 4-Way Cursor key to view the full image. A border around the full-size screen snapshot indicates that it is just a screen snapshot, not a “live” view. You can delete the selected image, or all images, by selecting a thumbnail and using Delete Image, or using Delete All Images from the Screen Snapshot X-Press™ menu.

Working with screen snapshots is a four-step process:

1. Enabling Screen Snapshot from the Accessories Menu.
2. Making a Screen Snapshot using the MARK key.
3. Viewing a Screen Snapshot using the Screen Snapshot View.
4. Deleting a Screen Snapshot using the Screen Snapshot X-Press™ menu.

For more information, see *Accessories Menu Tab: Using Screen Snapshot* and *Screen Snapshot X-Press™ Menu*.

When you start a screen snapshot, you will see a message that a waypoint has been created at the point where your cursor is on the screen, and the screen will freeze while the snapshot is being saved to the MMC/SD card. A status dialog box will appear that shows the progress of the save as a percentage, and that displays the numbered file name assigned to the .BMP file that is being created. Snapshot filenames begin with the letter "S". For more information, see the *Accessories Menu Tab: Using Screen Snapshot* procedure and *Screen Snapshot X-Press™ Menu*.

View Orientation

All the **Chart** views allow you to choose the orientation of the view. When **North-Up orientation** is selected, True North is shown at the top of the display. In other words, objects located to the north of the boat are drawn above the boat. When **Course-Up orientation** is selected, the direction of motion of the boat is shown at the top of the display. In other words, objects ahead of the boat are drawn above the boat. In both orientations, the view pans automatically, so that the boat is always centered on the display. When the boat is stationary, it is drawn as a circle. When the boat is in motion, it takes on a boat shape, pointed in the direction of motion (always Up in the Course-Up orientation).

Viewing Cartography

In the Chart Views, there are several cartography-related functions that you can access using various keys.

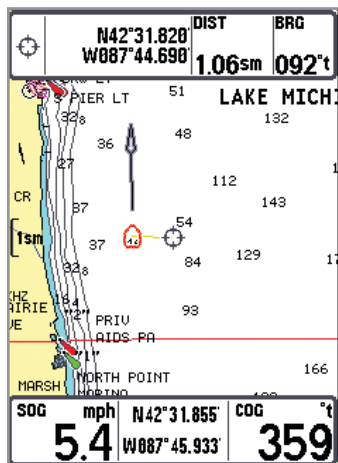

Chart View with Cursor Present,
shown with Optional-Purchase
Navionics® Cartography

Panning: Use the 4-WAY Cursor keys to move the chart around on the display in the direction of the key being pressed. When you do this, a bull's eye cursor is drawn at the center of the screen and is linked to the boat by a gray line, even if the boat is off the screen. At the same time, the distance and bearing from the boat to the cursor position and the latitude/longitude coordinates of the cursor are displayed in the upper info boxes.

Zooming: Use the Plus (+) key to Zoom In and the Minus (-) key to Zoom Out showing the cartography at different scales. The scale is indicated on the left side of the

display. If you zoom in beyond the available chart data, the display will go into Overzoom mode whereby the last available chart data is amplified to reflect the scale selected. If you zoom in so far that no cartography is available, a lat/lon grid will be drawn instead.

Chart Info: Use the INFO key to get detailed information about the chart through the Chart Info submenu. If the cursor is active, you will see information about the chart objects located near the cursor. If the cursor is not active, the Chart Info menu will appear. You can select the nearest port, the nearest tide station, or the nearest current station to see information about any of these objects using the 4-WAY Cursor Control key.

***NOTE:** The built-in UniMap™ does not contain any Port, Tide or Current information. This information is only available from optional-purchase MMC/SD cards.*

Chart Info Submenu

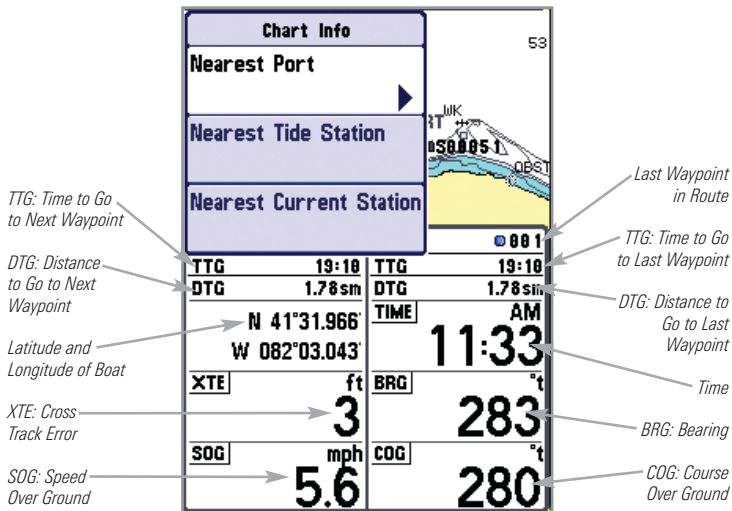

Nearest Port: The position and services information for the nearest port to your present position will be displayed in an information box. Press the EXIT key to remove the information box and the cursor bull's eye will be centered over the port position. The cursor information boxes at the bottom of the display will indicate the distance and bearing to the port from your present position. Press the EXIT key again to return to the Chart View.

Nearest Tide Station: Tide information for the nearest tide station to your present position will be displayed in an information box. This includes the position of the station and the times of the high and low tides for today's date. A tide graph is also displayed showing the rise and fall of the tides for the 24 hour time period encompassing the date. You can change the date to look at tide information before or after the date displayed by pressing the LEFT or RIGHT cursor key respectively. Press the EXIT key to remove the information box and the cursor bull's eye will be centered over the tide station position. The cursor information boxes at the bottom of the display will indicate the distance and bearing to the tide station from your present position. Press the EXIT key again to return to the Chart View.

Nearest Current Station: Current information for the nearest current station to your present position will be displayed in an information box. This includes the position of the station and the current changes for today. Two graphs are also presented that show the time, direction and flow speed of the current changes for the 24 hour time period of today's date. You can change the date to look at current information before or after the date displayed by pressing the LEFT or RIGHT cursor key respectively. Press the EXIT key to remove the information box and the cursor bull's eye will be centered over the current station position. The cursor information boxes at the bottom of the display will indicate the distance and bearing to the current station from your present position. Press the EXIT key again to return to the Chart View.

Introduction to Navigation

Use your Chartplotter to establish waypoints at areas of interest and to navigate to those waypoints via a savable route (representing the shortest intended distance between waypoints). You can also view and save tracks, which represent the actual path of the boat.

Waypoints, Routes and Tracks

Waypoints are stored positions that allow you to mark areas of interest or navigation points. Your Chartplotter can store up to 3000 waypoints.

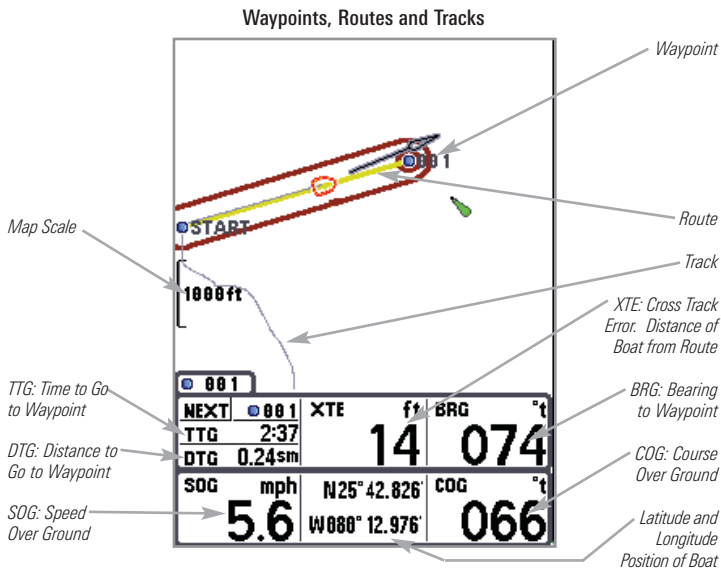

Routes link two or more waypoints together to create a path for navigation, and are used in trip planning. You can link individual waypoints together by using the GOTO key. A route represents your intended navigation and shows the shortest path from each waypoint to the next. As you travel a route, staying on the route line is the most efficient way to get to your destination, although you should always look out for obstacles not shown on the chart. Your 700 Series™ Chartplotter can store up to 50 routes that can each contain up to 50 waypoints.

Tracks consist of detailed position history, and are displayed as a breadcrumb trail of trackpoints. The Current Track shows the position history since the unit was powered up (maximum of 20,000 trackpoints displayed). You can clear the Current Track or save it at any time. Your 700 Series™ Chartplotter can store up to 50 saved tracks, each containing 20,000 trackpoints. The current track represents your actual path so far.

Save, Edit, or Delete a Waypoint

Save your current position as a waypoint: On any view, press the MARK key to save the current position of the boat as a waypoint.

Save the cursor position as a waypoint: On the Chart views, use the Cursor key to designate the position you want to save as a waypoint. Then press the MARK key to save the marked position as a waypoint.

*NOTE: When you save a waypoint by any of these methods, a numerical waypoint name is automatically assigned. You can edit the waypoint information later to give it a different name and select an icon to represent it (see **Waypoint submenu** on the **Navigation Main Menu Tab**).*

Display the Waypoints Submenu: From any view, press the MENU key twice to display the Main Menu System, then use the RIGHT Cursor key to select the Navigation tab. Select Waypoints and press the RIGHT Cursor key to display the Waypoints submenu.

Program a specific position as a waypoint: To create a waypoint that is NOT your current position, from the Waypoints submenu, select the Create option and press the RIGHT Cursor key. Use the Cursor keys to program a waypoint name, latitude, longitude, and icon before selecting Save.

Edit a waypoint: From the Waypoints submenu, select Edit and press the RIGHT Cursor key to display a list of saved waypoints. Select the waypoint you want to edit and press the RIGHT Cursor key. Use the 4-WAY Cursor Control key to move from field to field, and the UP and DOWN Cursor keys to change values once you are in a field. In the Waypoint Name, Latitude and Longitude fields, use the UP and DOWN Cursor keys to change the letter or number. All upper and lower case letters are available, as well as digits 0-9 and some punctuation characters. In the Waypoint Icon field, use the UP and DOWN Cursor keys to change the icon used to represent the waypoint on the Chart views. You can exit these fields with the LEFT and RIGHT Cursor keys or by pressing the EXIT key. Select Save and press the RIGHT Cursor key to save your changes.

To make it easier to select a waypoint, select **Sort By** and press the RIGHT or LEFT Cursor keys to select a sort order:

- **Name** shows the waypoints alphabetically
- **Time** shows the most recently-created waypoint first
- **Distance** shows the closest waypoint first.

Delete a waypoint: From the Waypoints submenu, select Delete and press the RIGHT Cursor key to display a list of waypoints. Select the waypoint you want to delete, then press the RIGHT Cursor key. You will be asked to confirm deletion before the waypoint is actually deleted.

Navigate to a Waypoint or Position

Navigate to the cursor position: From the Chart views, use the Cursor key to select a position or waypoint to which you want to navigate. Press the GOTO key. Navigation will begin immediately.

Navigate to a specified waypoint: Press the GOTO key, then choose the waypoint to which you would like to navigate from the waypoint list and press the RIGHT Cursor key to select it.

NOTE: By repeating the previous instructions, you can add more waypoints to create a longer multi-segment route.

Skipping a waypoint: From the Navigation X-Press™ menu, select Skip Next Waypoint and press the RIGHT Cursor key. If there is not another waypoint to skip to, navigation will be cancelled.

Cancel navigation: From the Navigation X-Press™ menu, select Cancel Navigation and press the RIGHT Cursor key. Canceling navigation removes the route and any waypoints created using the GOTO key, but does not remove any saved routes from memory. You will be prompted to save the current route when you cancel navigation.

Add a Waypoint Target or Trolling Grid

Add or Remove a Waypoint Target: From the Waypoints submenu, select Target and press the RIGHT Cursor key to display a list of waypoints. Select the waypoint you want to target. A target consisting of concentric circles centered on the selected waypoint will appear on all of the navigation views; the target shows various distance ranges from the targeted waypoint. To remove the target, choose Remove Target from the Navigation X-Press™ menu.

Chart View with Target

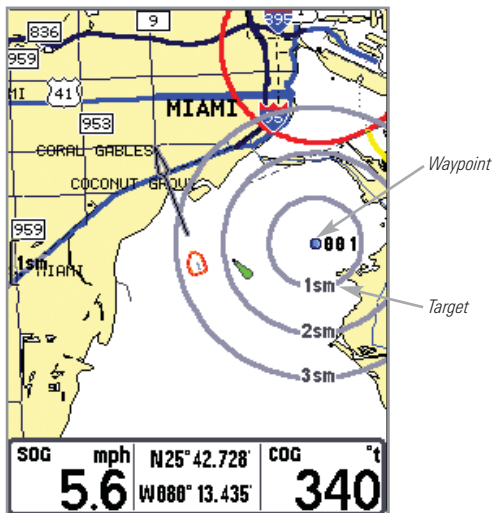

Add or Remove a Trolling Grid: From the Waypoints submenu, select Grid and press the RIGHT Cursor key to display a list of waypoints. Select the waypoint to which you want to add the grid. The trolling grid will appear on all of the navigation views, and can be used as a guide when trolling around a waypoint. The grid can be rotated to any desired heading using Grid Rotation from the Navigation Main menu. To remove the trolling grid, choose Remove Grid from the Navigation X-Press™ menu.



Save, Edit or Delete a Route

Save the current route: While you are navigating, the current route can be saved. From the Navigation X-Press™ menu, select Save Current Route and press the RIGHT Cursor key. Navigation will continue.

Display the Routes submenu: From any view, press the MENU key twice to display the Main Menu System, then use the RIGHT Cursor key to select the Navigation tab. Select Routes and press the RIGHT Cursor key to display the Routes submenu.

Create a route: From the Routes submenu, select Create and press the RIGHT Cursor key. A Route Edit screen will be displayed with an empty route. You can name the route, add waypoints to the route from the list of all waypoints, and order the waypoints in the route using the Cursor keys.

Edit a saved route: From the Routes submenu, select Edit and press the RIGHT Cursor key. A Route Edit screen will be displayed. Select the route you wish to edit and press the RIGHT Cursor key. Re-name the route or change, delete or re-order the waypoints used in the route.

Delete a saved route: From the Routes submenu, select Delete and press the RIGHT Cursor key. Select the route you wish to delete and press the RIGHT Cursor key. You will be asked to confirm your choice by pressing the RIGHT Cursor key again before the route is deleted.

Travel a saved route: From the Routes submenu, select Travel and press the RIGHT Cursor key. A list of saved routes will appear. Select the route you wish to travel and press the RIGHT Cursor key to make this route the current route and begin navigation. You may also travel the route in either forward or reverse order.

Route Info: From the Routes submenu, select Info and press the RIGHT Cursor key. A list of saved routes will appear. Select the route for which you want information, and press the RIGHT Cursor key. The list of waypoints in the route will be shown, with the distance and bearing from each waypoint to the next, as well as the distance and bearing from the current position to the first waypoint in the route.

Save or Clear a Current Track

Save the current track: From the Navigation X-Press™ menu, select Save Current Track and press the RIGHT Cursor key. The track will remain on the display, but will change from black to gray. To remove the track completely from the display, see *Edit, Delete or Hide Saved Tracks*.

*NOTE: When you save a track, a name is automatically assigned. The track name consists of a date/time stamp, but can be re-named later (see *Edit a Saved Track*).*

Clear the current track: From the Navigation X-Press™ menu, select Clear Current Track and press the RIGHT Cursor key. The track will be removed from the display and discarded.

Edit, Delete or Hide Saved Tracks

Display the Tracks Submenu: From any view, press the MENU key twice to display the Main Menu System, then use the RIGHT Cursor key to select the Navigation tab. Select Tracks and press the RIGHT Cursor key to display the Tracks submenu.

Edit a saved track: From the Tracks submenu, select Edit and press the RIGHT Cursor key to display the list of saved tracks. Select the track you want to edit and press the RIGHT Cursor key. When the Edit Track dialog box appears, use the Cursor keys to move between fields. In the Track Name field, the UP and DOWN Cursor keys change the letter or number. All upper and lower case letters are available, as well as digits 0-9 and some punctuation characters. You can exit the Track Name field with the LEFT and RIGHT Cursor keys or by pressing the EXIT key. Select Save and press the RIGHT Cursor key to save your changes.

Delete a saved track: From the Tracks submenu, select Delete and press the RIGHT Cursor key to display the list of saved tracks. Select the track you want to delete and press the RIGHT Cursor key. You will be asked to confirm deletion before the track is actually deleted.

Hide or display a saved track: From the Tracks submenu, select Visibility and press the RIGHT Cursor key to display the list of saved tracks. Select the track you want to hide or display and use the Cursor keys to select Hidden or Visible. Press the EXIT key to return to the Tracks submenu.

Man Overboard (MOB) Navigation

As soon as you know that you have a man overboard, you should activate MOB navigation to maximize chances for a successful rescue. MOB navigation allows you create an MOB waypoint to locate the point at which your man went overboard, and the relation of the boat to that point. When MOB is activated, an MOB waypoint, which is a permanent, sharable waypoint with a large, distinctive icon, is created at the boat's current position (regardless of whether the chart cursor is active or not). Any current navigation will be cancelled and the current route discarded without user notification, and MOB navigation will begin immediately. A line will be drawn from the boat's current position to the MOB waypoint, and the MOB waypoint will be targeted. The view is switched to the Chart View automatically when MOB is activated, and an additional info box that shows the lat/lon position of the MOB waypoint and the elapsed time since MOB was activated is added to the Chart View. This information will automatically be added to the Bird's Eye and Instrument Views as well.

It is not possible to re-activate MOB or modify the current route without first canceling MOB navigation. The Off Course trigger is also disabled and the Off Course Alarm circle is not drawn. Any press of the GOTO key, or selection of a GOTO menu item, will cause an error beep and a short message will be displayed to the user that will disappear after 2 seconds.

Activate MOB navigation: Press and hold the GOTO key for more than 1.5 seconds to activate the Man Overboard (MOB) function.

Cancel MOB navigation: From the Navigation X-Press™ menu, select Cancel MOB and press the RIGHT Cursor key. Canceling MOB navigation removes the route and any waypoints created using the GOTO key, but does not remove any saved routes from memory, nor does it remove the MOB waypoint. To delete the MOB waypoint after you have cancelled MOB navigation, use the Navigation X-Press™ menu to select the MOB Waypoint, then press the RIGHT Cursor key to view the MOB Waypoint submenu, then use the 4-WAY Cursor Control keys to delete the MOB Waypoint.

***NOTE:** The actual MOB waypoint will remain in the Navigation X-Press™ menu until you delete it manually. To delete the MOB waypoint after you have cancelled MOB navigation, select it from the Navigation X-Press™ menu using the RIGHT 4-WAY Cursor Control key, then select Delete from the MOB Waypoint submenu. A confirmation dialog box will appear, allowing you to confirm the deletion or to cancel it.*

Man Overboard (MOB) Navigation

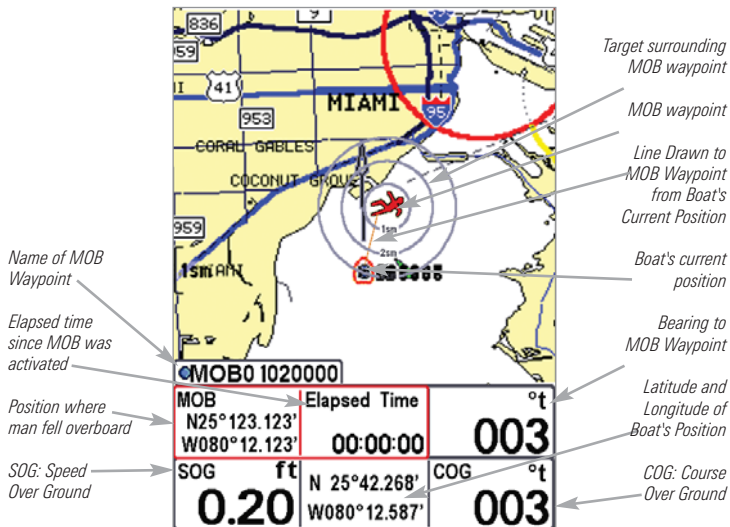

Key Functions

Your Chartplotter user interface consists of a set of easy-to-use keys that work with various on-screen views and menus to give you flexibility and control over your fishing experience.



POWER/LIGHT Key

The POWER/LIGHT key is used to turn the Chartplotter on and off, and also to adjust the backlight and background color of the display. Press the POWER/LIGHT key to turn the unit on. The Title screen is then displayed until the Chartplotter begins operation. See *Powering Up the Unit* for a more detailed explanation of the different modes you can select on power up.

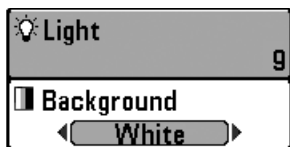

To adjust the backlight, or to adjust the display background color, press the POWER/LIGHT key to access the Light and Background menu. Use the 4-WAY Cursor key to select Light or Background and then use the LEFT or RIGHT Cursor key to change the settings. Press EXIT to exit the Light and Background menu.

Press and hold the POWER/LIGHT key for 3 seconds to turn the unit off. A message will appear telling you how many seconds there are until shutdown occurs. Your Chartplotter should always be turned off using the POWER/LIGHT key. This will ensure that shutdown occurs properly and any menu settings will be saved.



VIEW Key

The VIEW key is used to cycle through all available views. Press the VIEW key to advance to the next view. Repeatedly pressing VIEW cycles through all views available. Views can be hidden to optimize the system to your fishing requirements (see *Views Menu Tab*).



INFO Key

Info - Press the INFO key while in the Bird's Eye or Chart views to display information about objects that are nearest to an active cursor.

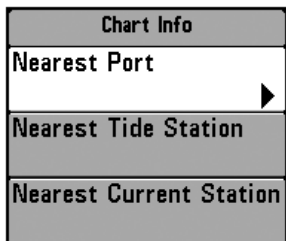

If the cursor is not active, the following menu will be displayed. Use the 4-WAY Cursor key to select Nearest Port, Nearest Tide Station or Nearest Current Station, then use the RIGHT Cursor key to display the requested information.

NOTE: The built-in UniMap™ does not contain Port, Tide or Current information. This information is only available from optional purchase MMC/SD cards.



MENU Key

The MENU key is used to access the menu system.

Start-Up Options Menu - Press the MENU key during the power up sequence to view the Start-Up Options menu.

X-Press™ Menu - Press the MENU key once for the X-Press™ Menu. The X-Press™ menu allows you to access frequently-used settings without having to navigate through the whole menu system. When the X-Press™ menu is displayed, you can use the UP or DOWN Cursor keys to move to a particular menu choice. As soon as you alter a parameter (using the RIGHT or LEFT Cursor keys) the X-Press™ menu will collapse temporarily, and the screen will update if it is affected by your menu setting change, allowing you to see the effects of your action immediately. Reactivate the X-Press™ Menu by using the UP or DOWN Cursor keys.

Main Menu - Press the MENU key twice for the tabbed Main Menu System. The Main Menu System is organized under tabbed headings to help you find a specific menu item quickly: Alarms, Navigation, Chart, Setup, Views and Accessories tabs are part of your tabbed Main Menu System. Use the LEFT or RIGHT 4-WAY Cursor Control key to select a tab; then use the DOWN or UP key to select the menu item, and the LEFT or RIGHT key to alter a menu setting.



4-WAY Cursor Control Key

Use the DOWN or UP 4-Way Cursor Control keys to select a menu choice from the menu list, then use the LEFT or RIGHT arrow keys to change a menu setting.

NOTE: Menu choices are implemented and saved immediately - no further action is required.



MARK Key

Press the MARK key while in any view to mark the position of a waypoint, either at the current boat location, or, if the Cursor is active, at the current Cursor location.

The MARK key only functions if you have the GPS receiver connected, or if you have enabled Screen Snapshot from the Accessories menu tab. If you have enabled the Screen Snapshot feature, pressing the MARK key still creates a waypoint, but it also captures the screen image to the optional-purchase MMC/SD card.

NOTE: You must have an optional-purchase MMC/SD card installed for the screen snapshot feature to work.

Navigation is not affected by the Screen Snapshot feature. Also, if Screen Snapshot is enabled but there is no GPS receiver connected, pressing the MARK key will capture the screen image and display an error saying that a GPS position fix is required to create a waypoint.



GOTO Key

The GOTO Key has multiple functions, depending on the situation:

- If the Cursor is active, pressing the GOTO key while in any view creates a waypoint and starts navigation towards that waypoint. If the Cursor is not active, pressing the GOTO key displays the list of waypoints, so that you can select the waypoint towards which you want to navigate.
- If the GOTO key is pressed and held for more than 1.5 seconds, the Man Overboard (MOB) function is activated. When MOB is activated, an MOB waypoint, which is a permanent, sharable waypoint with a large,

distinctive icon, is created at the boat's current position (regardless of whether the chart cursor is active or not). Any current navigation will be cancelled and the current route discarded without user notification, and MOB navigation begins immediately. The view is switched to the Chart View automatically when MOB is activated, and it is not possible to activate MOB or modify the current route without first canceling MOB navigation. Any press of the GOTO key, or selection of a GOTO menu item, will cause an error beep and a short message will be displayed to the user that will disappear after 2 seconds.



ZOOM (+/-) Key

Press the - or + ZOOM keys while in any of the Chart or Bird's Eye Views to change the scale of the view to appear closer or farther away.



EXIT Key

The EXIT key has multiple functions, depending on the situation:

- If an alarm is sounding, pressing EXIT will cancel the alarm.
- If a menu tab is selected, pressing EXIT will exit the menu mode and return to the view.
- If a menu is active, pressing EXIT will return to the previous level in the menu system.
- Pressing EXIT will cycle through the available views in reverse order.
- If the Cursor is active, pressing EXIT will remove the cursor from the display.

Accessory Bus

Use the **Accessory Bus** to expand the functionality of your Chartplotter. Accessories plug directly into the Chartplotter, enabling Advanced features such as WeatherSense® and the SmartCast® Wireless Sonar Link. Additional tabs and menu choices will be added to the menu system automatically when an accessory is plugged into the unit. In addition, multiple accessories can be attached simultaneously. See *Accessories Menu Tab* and *700 Series™ Chartplotter Accessories* in this manual, as well as your accessory's Operations Manual for additional details.

NOTE: Accessories to enable WeatherSense® and the SmartCast® Wireless Sonar Link require separate purchases. You can visit our website at www.humminbird.com or contact our Customer Resource Center at **1-800-633-1468** for additional details.

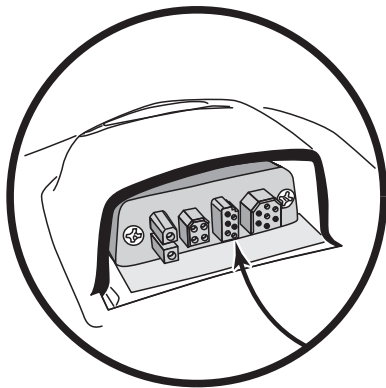

Powering Up the Unit

Turn on your Chartplotter by pressing the POWER/LIGHT key. The Title screen is displayed until the Chartplotter begins operation. After the Title screen is displayed, a 30 second Navigation Warning screen is shown. Press the MENU key during the time that the Title screen is displayed to view the Start-Up Menu in order to choose Simulator mode. Press the EXIT key during the Navigation Warning to enter into Normal mode. If you don't press any key during the Navigation Warning, and Demonstration is turned on, your Chartplotter automatically goes into Demonstration Mode. You can turn off Demonstration Mode if desired (see *Setup Menu: Demonstration*).

785c² Title Screen



The Menu System

The menu system is divided into easy-to-use menu modules. The main components of the menu system are:

Start-Up Options Menu - Press the MENU key during the power up sequence to view the Start-Up Options menu.

Waypoint 001
Cursor To Waypoint
Save Current Track
Clear Current Track
Save Current Route
Skip Next Waypoint
Cancel Navigation
Cancel MOB Navigation
Remove Target
Remove Grid
Waypoint 00153
Select Readouts

X-Press™ Menu

X-Press™ Menu - The X-Press™ Menu allows you to access the settings that are changed frequently without having to navigate through the whole menu system. Press the MENU key once to display the X-Press™ Menu. When you select a menu item from the X-Press™ Menu, the menu will collapse, leaving only the menu choice on the screen. Use the UP or DOWN Cursor keys to reactivate the X-Press™ Menu.

NOTE: The X-Press™ Menu choices will vary depending on which view is active when you press the MENU key, as well as whether you are in Normal or Advanced User Mode. Either the Navigation or Screen Snapshot X-Press™ Menu will appear, depending on the view you are in.

Alarms	
Low Battery Alarm	Off
Aux. Temp. Alarm	Off
Temp. Alarm	Off
Off Course Alarm	600ft
Arrival Alarm	Off
Drift Alarm	Off
Alarm Tone	Medium

Main Menu System
Normal User Mode

Main Menu Tabs - Less frequently-adjusted menus are grouped into the Main Menu System. The Main Menu system is organized under the following tab headings to help you find a specific menu item quickly: Alarms, Navigation, Chart, Setup, Views and Accessories.

Press the MENU key twice for the Main Menu, then use the 4-WAY Cursor LEFT or RIGHT key to select a tab, and use the DOWN or UP key to select a specific menu item under that tab, then use the LEFT or RIGHT keys again to change a menu setting. Press the EXIT key to move quickly to the top of the tab. A down arrow at the bottom of a menu means that you can scroll to additional menu choices using the DOWN Cursor key. A right or left arrow on a menu choice means that you can use the RIGHT or LEFT Cursor keys to make changes or to see more information.

NOTE: The Main Menu choices will vary depending on whether you are in Normal or Advanced User Mode.

User Mode (Normal or Advanced) - An Advanced Mode is provided for users who desire the highest level of control over the Chartplotter and Normal Mode for users who desire greater simplicity and fewer menu choices. Additional Advanced menu choices will be displayed throughout the menu system when you navigate to specific menus while in Advanced Mode. Any changes made while in Advanced Mode will remain in effect after you switch back to Normal Mode. See *Setup Menu Tab: User Mode* for specific instructions on changing to Advanced User Mode.

Setup	
Units - Depth	Feet
Units - Distance	Statute Miles
Units - Speed	mph
User Mode	Normal
Triplog Reset	
Restore Defaults	

Setup Tab, Normal Mode

Setup	
Units - Depth	Feet
Units - Temp	°f
Units - Distance	Statute Miles
Units - Speed	mph
User Mode	Advanced
Triplog Reset	
Restore Defaults	
Aux. Temp. Offset	0.0°
Temp. Offset	0.0°
Speed Calibration	0%
Local Time Zone	EST (UTC-5)
Daylight Saving Time	Off
Position Format	dd°mm.mmm'
Time Format	12-hour
Date Format	mm/dd/yy
Digits Format	Large tenths
NMEA Output	Off
Demonstration	Off

Setup Tab, Advanced Mode

Total Screen Update - when you change any menu settings that affect the display, the view will update immediately (i.e. you don't have to exit the menu to apply the change to the screen).

Start-Up Options Menu

Press the MENU key when the Title screen is displayed to access the **Start-Up Options** menu.

Use the UP or DOWN 4-WAY Cursor keys to position the cursor, then the RIGHT Cursor key to select one of the following choices. If you wait too long, the system will default to whichever menu happens to be highlighted:

- Normal
- Simulator
- System Status
- PC Connect (use with PC Connect Cable).

See the following paragraphs for more information about each of these choices.

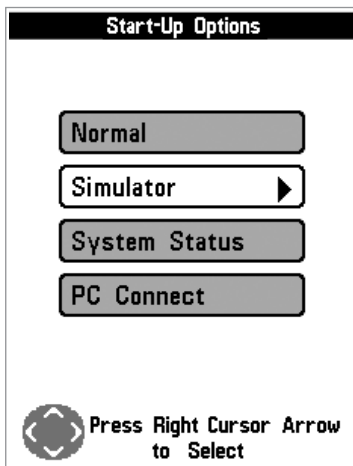

Normal Operation

Use **Normal Operation** for on the water operation. Turn on your Chartplotter by pressing the POWER/LIGHT key. The Title screen is displayed until the Chartplotter begins operation. After the Title screen is displayed, a 30 second Navigation Warning screen is shown. Press the MENU key during the time that the Title screen is displayed to view the Start-Up Menu in order to choose Simulator mode. Press the EXIT key during the Navigation Warning to enter into Normal mode.

Simulator

Use the **Simulator** to learn how to use your Chartplotter before taking your boat on the water. The Simulator is a very powerful tool that simulates on the water operation, providing a randomly-updated display. We recommend going through this manual while using the Simulator, since all of the menu function and affect the display the way they actually do when in Normal operation.

***NOTE:** At startup, while still on the splash screen (while the name of your Humminbird(r) model is still on the screen) you must press the MENU key and then select Simulator manually to enter Simulator mode. Manually selecting Simulator from the Start-Up Options menu allows you to pre-configure your Chartplotter for on the water operation. Any menu changes you make will be saved for later use.*

A message will appear on the display periodically to remind you that you are using the Simulator.

Exit the Simulator by powering your Chartplotter off.

Simulator (shown with optional-purchase
Weathersense® attached)

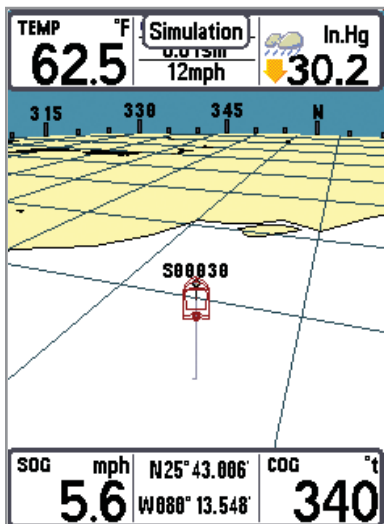

System Status

Use **System Status** to view system connections and to conduct a unit self-test.

The following screens are displayed in turn when you press the VIEW button when using System Status:

- Self Test
- Accessory Test
- GPS Diagnostic View.

Exit System Status by powering your Chartplotter off.

Self Test

Self Test displays results from the internal diagnostic self test, including unit serial number, Printed Circuit Board (PCB) serial number, software revision, total hours of operation and the input voltage.

Self Test Screen

SYSTEM STATUS	
SELF TEST	
PASSED	
S/N	
0-1-1000000000	
SOFTWARE VERSION	
2.005	
VOLTAGE	TOTAL TIME
13.8 ^V	84 ^{hrs}
PCB S/N	
0-0-0000000	
Press VIEW for Next Screen	

Accessory Test

Accessory Test lists the accessories connected to the system.

System Status Accessory Test Screen

SYSTEM STATUS	
ACCESSORY TEST	
GPS	UNCONNECTED
SmartCast WSL	UNCONNECTED
Speed	CONNECTED
Temperature	CONNECTED
WeatherSense	UNCONNECTED
Exit SYSTEM STATUS by powering the unit off	

NOTE: The speed accessory will be detected only if the paddlewheel has moved since your Chartplotter was powered up.

GPS Diagnostic View

GPS Diagnostic View shows a sky chart and numerical data from the GPS receiver. The sky chart shows the location of each visible GPS satellite with its satellite number and a signal strength bar. A dark gray bar indicates that the satellite is being used to determine your current position. A light orange bar indicates that the satellite is being monitored, but is not yet being used.

This view also reports the current position, local time and date, and other numeric information. The current GPS Fix Type is reported as No Fix, 2D Fix, 3D Fix, or Enhanced. An Enhanced fix has been augmented using information from WAAS, EGNOS, or MSAS. A 3D or Enhanced Fix is required for navigation. HDOP (the Horizontal Dilution of Precision) is a GPS system parameter which depends on the current satellite configuration. HDOP is used to calculate the Estimated Position Error.

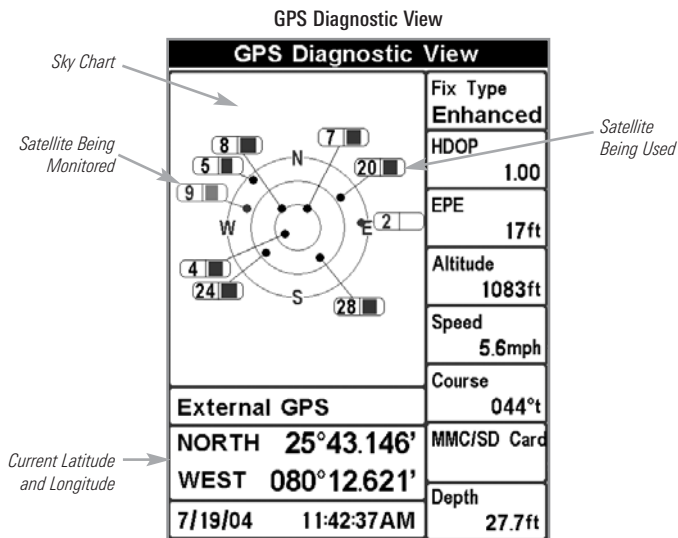

PC Connect *(with PC Connect cable only)*

Use **PC Connect** to update the software of the Chartplotter control head. This feature requires the use of the PC Connect Cable. Complete instructions are included with the PC Connect Cable accessory.

***NOTE:** The PC Connect Cable requires a separate purchase. For more information visit our website at www.humminbird.com or contact our Customer Resource Center at 1-800-633-1468.*

Exit PC Connect mode by powering the Chartplotter off.

Waypoint 001
Cursor To Waypoint
Save Current Track
Clear Current Track
Save Current Route
Skip Next Waypoint
Cancel Navigation
Cancel MOB Navigation
Remove Target
Remove Grid
Waypoint 00153
Select Readouts

Navigation X-Press™ Menu

Navigation X-Press™ Menu

(Navigation views only)

The **Navigation X-Press™** menu provides access to the settings most frequently used. Press the MENU key once while in any of the Navigation views to access the Navigation X-Press™ menu.

NOTE: Menu choices will vary depending on system settings, such as whether you are currently navigating.

Waypoint [Name]

(Only with an active cursor on a waypoint)

Waypoint [Name] allows you to view the Waypoints submenu for the waypoint under your cursor.

To view the Waypoint [Name] Submenu:

1. Move the cursor onto an existing waypoint and press the MENU key once, or use **Cursor to Waypoint** to select a waypoint from a list of saved waypoints.
2. Highlight **Waypoint [Name]** on the Navigation X-Press™ menu.
3. Use the RIGHT 4-Way Cursor Control key to view the Waypoints submenu, which contains the following menu choices:



Waypoint Submenu

The Waypoint Submenu contains the following menu choices:

Edit allows you to edit the Name, Position (Latitude and Longitude) and select the Icon that will be used to represent the waypoint in the Chart Views.

Delete allows you to delete a waypoint from the list of saved waypoints.

Target allows you to apply a target to a waypoint selected from the list of waypoints.

Grid allows you to apply a trolling grid to a waypoint selected from the list of waypoints.

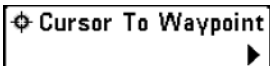

Cursor to Waypoint

(Chart views only)

Cursor to Waypoint allows you to quickly move the cursor to any saved waypoint, so that you can locate it or edit it.

NOTE: This X-Press™ menu item appears only if you have saved waypoints.

To move cursor to a saved waypoint:

1. Highlight Cursor to Waypoint on the Navigation X-Press™ menu.
2. Use the RIGHT 4-WAY Cursor Control key to initiate Cursor to Waypoint.
3. Use the UP or DOWN 4-WAY Cursor Control key to highlight the waypoint you wish to move the cursor to, then use the RIGHT 4-WAY Cursor Control key to select the destination waypoint.

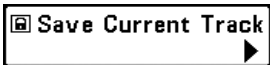

Save Current Track

Save Current Track allows you to save the current track being displayed. After the current track is saved, a new current track is started.

To Save Current Track:

1. Highlight Save Current Track on the Navigation X-Press™ menu.
2. Use the RIGHT 4-WAY Cursor Control key to initiate saving the current track.
3. The Confirm dialog box will appear. To save the current track, press the RIGHT Cursor key once more. To cancel saving the current track, press the LEFT Cursor key.

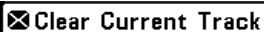
 **Clear Current Track**

Clear Current Track

Clear Current Track allows you to clear the current track being displayed and start a new track at the present position.

To Clear Current Track:

1. Highlight Clear Current Track on the Navigation X-Press™ menu.
2. Use the RIGHT 4-WAY Cursor Control key to initiate clearing the current track.
3. The Confirm dialog box will appear. To clear the current track, press the RIGHT Cursor key once more. To cancel clearing the current track, press the LEFT Cursor key.

 **Save Current Route**

Save Current Route

(only when Navigating)

Save Current Route allows you to save the current route being displayed. This menu choice will only appear when you are currently navigating a route.

To Save Current Route:

1. Highlight Save Current Route on the Navigation X-Press™ menu.
2. Use the RIGHT 4-WAY Cursor Control key to initiate saving the current route.
3. The Confirm dialog box will appear. To save the current route, press the RIGHT Cursor key once more. To cancel saving the current route, press the LEFT Cursor key.

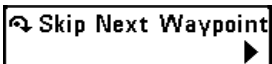

Skip Next Waypoint

(only when Navigating)

Skip Next Waypoint removes the next waypoint from the current route. This menu choice will only appear when you are currently navigating a route.

To Skip Next Waypoint:

1. Highlight Skip Next Waypoint on the Navigation X-Press™ menu.
2. Use the RIGHT 4-WAY Cursor Control key to initiate skipping the next waypoint.
3. The Confirm dialog box will appear. To skip the next waypoint, press the RIGHT Cursor key once more. To cancel skipping the next waypoint, press the LEFT Cursor key.

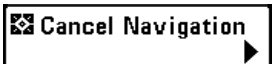

Cancel Navigation

(only when Navigating)

Cancel Navigation discards the current route and exits Navigation Mode. This menu choice will only appear when you are currently navigating a route. This will not delete a previously-saved route.

To Cancel Navigation:

1. Highlight Cancel Navigation on the Navigation X-Press™ menu.
2. Use the RIGHT 4-WAY Cursor Control key to initiate canceling navigation.
3. The Confirm dialog box will appear. To cancel navigation, press the RIGHT Cursor key once more. To avoid canceling navigation, press the LEFT Cursor key.

 **Cancel MOB Navigation**

Cancel MOB Navigation

(only when MOB Navigation is activated)

Cancel MOB Navigation exits Man Overboard mode. This menu choice will only appear when you are currently navigating in Man Overboard mode.

To Cancel MOB Navigation:

1. Highlight Cancel MOB Navigation on the Navigation X-Press™ menu.
2. Use the RIGHT 4-WAY Cursor Control key to initiate canceling MOB navigation.
3. The Confirm dialog box will appear. To cancel MOB navigation, press the RIGHT Cursor key once more. To avoid canceling MOB navigation, press the LEFT Cursor key.

***NOTE:** The actual MOB waypoint will remain in the Navigation X-Press™ menu until you delete it manually. To delete the MOB waypoint after you have cancelled MOB navigation, select it from the Navigation X-Press™ menu using the RIGHT 4-WAY Cursor Control key, then select Delete from the MOB Waypoint submenu. A confirmation dialog box will appear, allowing you to confirm the deletion or to cancel it.*

 **Remove Target**

Remove Target

(only if a Target is Active)

Remove Target removes the waypoint target from the display. This menu choice will only appear when a target has already been applied to a waypoint.

***NOTE:** See **Add a Waypoint Target** or **Trolling Grid** for more information.*

To Remove a Target:

1. Highlight Remove Target on the Navigation X-Press™ menu.
2. Use the RIGHT 4-WAY Cursor Control key to remove the target.



Remove Grid

(only if a Grid is Active)

Remove Grid removes the waypoint grid from the display. This menu choice will only appear when a grid has already been applied to a waypoint.

NOTE: See Add a Waypoint Target or Trolling Grid for more information.

To Remove a Grid:

1. Highlight Remove Grid on the Navigation X-Press™ menu.
2. Use the RIGHT 4-WAY Cursor Control key to remove the grid.



Waypoint [Name]

(Most recently-created waypoint)

Waypoint [Name] allows you to view the waypoints submenu for the most recently created waypoint.

NOTE: You must have pressed the MARK key at least once since you last powered up the Chartplotter for this menu choice to appear.

To view the Waypoint [Name] Submenu:

1. Move the cursor to the desired position and press the MARK key once to save a waypoint.
2. Highlight Waypoint[Name] on the Navigation X-Press™ menu.
3. Use the RIGHT 4-Way Cursor Control key to view the Waypoints submenu.

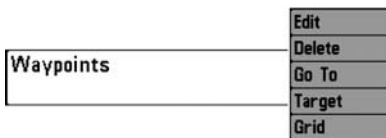

Waypoint [Name] Submenu

The Waypoint Submenu contains the following menu choices:

Edit allows you to edit the Name, Position (Latitude and Longitude) and select the Icon that will be used to represent the waypoint in the Chart Views.

Delete allows you to delete a waypoint from the list of saved waypoints.

Go To allows you to select a waypoint and start navigation toward that waypoint, or add that waypoint to the end of the current route.

Target allows you to apply a target to a waypoint selected from the list of waypoints.

Grid allows you to apply a trolling grid to a waypoint selected from the list of waypoints.

Select Readouts

Select Readouts sets individual digital readouts on the Instrument View, all the Chart Views, and the Bird's Eye Views. This feature allows you to select what data will be displayed in each of a variable number of fixed-position data windows arranged around the edges of the screen on various views, or whether a particular window will be turned off, displaying nothing in that area. Data windows can display readouts from supported accessories such as Temp/Speed.

NOTE: Standard Bird's Eye View and Chart View share the same set of 9 readouts, 7 of which are adjustable. When you change the readouts display on the Bird's Eye View, you also are changing them on the Chart View.

NOTE: Bird's Eye Big Digits View, Chart Big Digits View, and Instrument View all share the same set of 8 readouts. When you change the readouts display on one of these three views, you are also changing them on the other two views. See **Bird's Eye View**, **Chart View**, and **Instrument View** for more information.

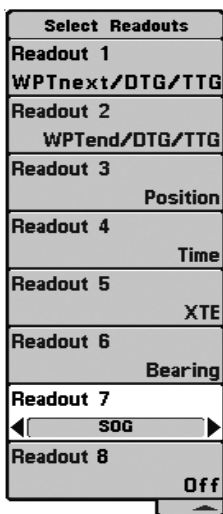

Select Readouts: 8 Data Windows
Used by Bird's Eye Big Digits,
Chart Big Digits,
and Instrument View

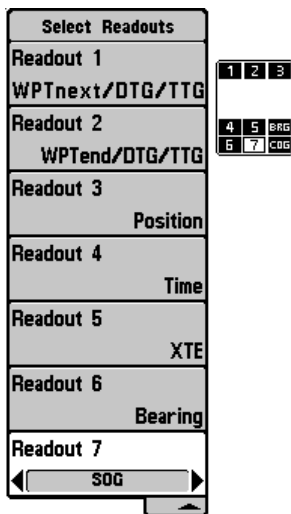

Select Readouts: 9 Data Windows,
7 Adjustable, Used by Standard
Bird's Eye and Chart View

Each data window can either be empty or contain one of the following (varies by position and by view):

**9 Data Windows, 7 Adjustable, Used by Standard Bird's Eye and Chart Views
Readouts 1, 2, 3, 6 and 7**

COG	Course Over Ground; Course Over Ground is the current direction the boat is traveling measured in degrees from North (i.e. 321°, where 000° is North, 090° East, 180° is South, 270° is West). When the Course Over Ground is equal to Bearing, the boat is said to be "On Course" and will arrive at the destination in the most efficient manner. See the Glossary for more information.
Off	Suppresses the readout so that no data shows in that position.
Position	Position is the current location (latitude, longitude) determined by GPS.
SOG	Speed Over Ground; Speed Over Ground is the measurement of the boat's progress across a given distance, and is the speed measurement provided by GPS; accurate destination times can be derived from this measurement. See the <i>Glossary</i> for more information.
Time	The current time.
Time + Date	The current time and date.
Triplog	Displays the triplog, which measures the elapsed time since last reset, the distance traveled since last reset, and average speed during timed interval.
Voltage	Power supplied to the control head.

9 Data Windows, 7 Adjustable, Used by Standard Bird's Eye and Chart Views Readouts 4 and 5

Bearing	Bearing is the direction to a destination waypoint measured in degrees from North (i.e. 321°, where 000° is North, 090° East, 180° is South, 270° is West).
CMG/SMG	Course Made Good/Speed Made Good. Course Made Good is the angle between the starting point on a route and the current position of the boat. The goal is to have CMG and Track equal to the same number. See the <i>Course Made Good</i> illustration. Speed Made Good is the distance from the starting waypoint on the route divided by the time elapsed since starting navigation on the route.
Off	Suppresses the readout so that no data shows in that position.
TRK/CMG	Track/Course Made Good. The Track is the desired line of travel between two waypoints, and represents the most efficient path between the two points because it is a straight line. The TRK is measured in degrees. See above for an explanation of Course Made Good.
TTG	Time To Go. Time To Go is the estimated time required to reach the destination waypoint. TTG is calculated using the SOG and DTG.
VMG	Velocity Made Good. Velocity Made Good is the speed of travel relative to the next waypoint on the route. The goal is for VMG to equal Speed.
WPTend/ETA/DTG	Waypoint End/Estimated Time of Arrival/Distance to Go. Waypoint End is the last waypoint on the route. Estimated Time of Arrival is the estimated time of arrival to the last waypoint on the route. Distance To Go is the distance between the current position of the boat and the last waypoint on the route.

9 Data Windows, 7 Adjustable, Used by Standard Bird's Eye and Chart Views Readouts 4 and 5 (con't.)

WPTend/TTG/DTG	Waypoint End/Time To Go/Distance to Go. Waypoint End is the last waypoint on the route. Time To Go is the estimated time required to reach the last waypoint on the route. TTG is calculated using the SOG and DTG. Distance To Go is the distance between the current position of the boat and the last waypoint on the route.
WPTnext/ETA/DTG	Waypoint Next/Estimated Time of Arrival/Distance to Go. Waypoint Next is the next waypoint on the route. Estimated Time of Arrival is the estimated time of arrival to the next waypoint on the route. Distance To Go is the distance between the current position of the boat and the next waypoint on the route.
WPTnext/TTG/DTG	Waypoint Next/Time To Go/Distance to Go. Waypoint Next is the next waypoint on the route. Time To Go is the estimated time required to reach the next waypoint on the route. TTG is calculated using the SOG and DTG. Distance To Go is the distance between the current position of the boat and the next waypoint on the route.
Waypoint/TTG	Waypoint/Time To Go. Waypoint/Time To Go for the next waypoint on the route.
XTE	Cross Track Error. Cross Track Error is the straight-line distance of the boat from the intended Track. XTE measures how far the boat is off course, and also triggers the Off Course Alarm.

**8 Adjustable Data Windows, Used by Bird's Eye Big Digits,
Chart Big Digits, and Instrument View
Readouts 1, 2, 3, 4, 5, 6, 7 and 8**

Bearing	Bearing is the direction to a destination waypoint measured in degrees from North (i.e. 321°, where 000° is North, 090° East, 180° is South, 270° is West).
CMG/SMG	Course Made Good/Speed Made Good. Course Made Good is the angle between the starting point on a route and the current position of the boat. The goal is to have CMG and Track equal to the same number. See the <i>Course Made Good</i> illustration. Speed Made Good is the distance from the starting waypoint on the route divided by the time elapsed since starting navigation on the route.
COG	Course Over Ground. Course Over Ground is the current direction the boat is traveling measured in degrees from North (i.e. 321°, where 000° is North, 090° East, 180° is South, 270° is West). When the Course Over Ground is equal to Bearing, the boat is said to be "On Course" and will arrive at the destination in the most efficient manner. See the <i>Glossary</i> for more information.
Off	Suppresses the readout so that no data shows in that position.
Position	Position is the current location (latitude, longitude) determined by GPS.
SOG	Speed Over Ground. Speed Over Ground is the measurement of the boat's progress across a given distance, and is the speed measurement provided by GPS; accurate destination times can be derived from this measurement. See the <i>Glossary</i> for more information.

**8 Adjustable Data Windows, Used by Bird's Eye Big Digits,
Chart Big Digits, and Instrument View
Readouts 1, 2, 3, 4, 5, 6, 7 and 8 (con't.)**

TRK/CMG	Track/Course Made Good. The Track Line is the desired line of travel between two waypoints, and represents the most efficient path between the two points because it is a straight line. The TRK is measured in degrees. See above for an explanation of Course Made Good.
TTG	Time To Go. Time To Go is the estimated time required to reach the destination waypoint. TTG is calculated using the SOG and DTG.
Time	The current time.
Time + Date	The current time and date.
Triplog	Displays the triplog, which measures the elapsed time since last reset, the distance traveled since last reset, and average speed during timed interval.
VMG	Velocity Made Good. Velocity Made Good is the speed of travel relative to the next waypoint on the route. The goal is for VMG to equal Speed.
Voltage	Power supplied to the control head.
WPTend/ETA/DTG	Waypoint End/Estimated Time of Arrival/Distance to Go. Waypoint End is the last waypoint on the route. Estimated Time of Arrival is the estimated time of arrival to the last waypoint on the route. Distance To Go is the distance between the current position of the boat and the last waypoint on the route.
WPTend/TTG/DTG	Waypoint End/Time To Go/Distance to Go. Waypoint End is the last waypoint on the route. Time To Go is the estimated time required to reach the last waypoint on the route. TTG is calculated using the SOG and DTG. Distance To Go is the distance between the current position of the boat and the last waypoint on the route.

**8 Adjustable Data Windows, Used by Bird's Eye Big Digits,
Chart Big Digits, and Instrument View
Readouts 1, 2, 3, 4, 5, 6, 7 and 8 (con't.)**

WPTnext/ETA/DTG	Waypoint Next/Estimated Time of Arrival/Distance to Go. Waypoint Next is the next waypoint on the route. Estimated Time of Arrival is the estimated time of arrival to the next waypoint on the route. Distance To Go is the distance between the current position of the boat and the next waypoint on the route.
WPTnext/TTG/DTG	Waypoint Next/Time To Go/Distance to Go. Waypoint Next is the next waypoint on the route. Time To Go is the estimated time required to reach the next waypoint on the route. TTG is calculated using the SOG and DTG. Distance To Go is the distance between the current position of the boat and the next waypoint on the route.
Waypoint/TTG	Waypoint/Time To Go. Waypoint/Time To Go for the next waypoint on the route.
XTE	Cross Track Error is the straight-line distance of the boat from the intended Track. XTE measures how far the boat is off course, and also triggers the Off Course Alarm.

Default Chart View

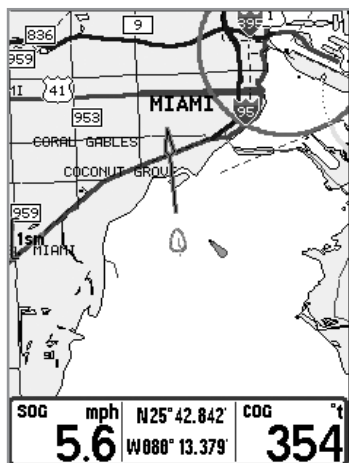

Customized Chart View

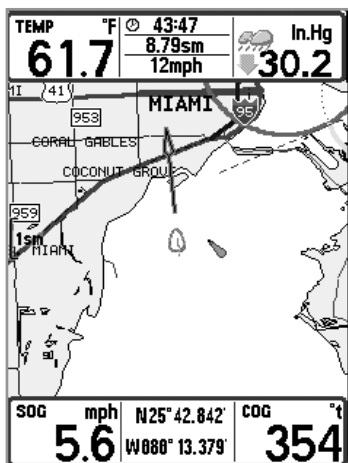

To Select Readouts:

1. Highlight Select Readouts on the Navigation X-Press™ menu.
2. Use the RIGHT 4-WAY Cursor Control key to initiate this procedure.
3. The Select Readouts submenu will appear, showing a list of all Readouts. Use the UP or DOWN Cursor keys to select a particular Readout position, then use the RIGHT or LEFT Cursor keys to change what will be displayed at that position.

NOTE: The selections for each readout will vary, depending on which view you are in and which readout position you are setting. See the preceding tables to find your view and the selectable data windows that are available for each readout position in that view.



Screen Snapshot X-Press™ Menu

Screen Snapshot X-Press™ Menu

(Screen Snapshot View only)

The **Screen Snapshot X-Press™** menu provides access to the image management functions. Press the MENU key once while in the Screen Snapshot View to access the Screen Snapshot X-Press™ menu.

***NOTE:** For more information, see **Screen Snapshot View**.*

Delete Image**Delete Image**

(optional-purchase MMC/SD Card only)

Delete Image allows you to delete a single screen capture image from the Screen Snapshot View. This menu option is only available when you have an optional-purchase MMC/SD card installed and you are in Screen Snapshot View and you have selected an image thumbnail.

To delete an image:

1. On the Screen Snapshot View, use the UP and DOWN 4-Way Cursor keys to select the image you want to delete.
2. Highlight Delete Image on the Screen Snapshot X-Press™ menu.
3. Press the RIGHT 4-Way Cursor key to initiate this procedure.
4. A Confirm Dialog box will appear. Select Yes to delete the image or No to cancel the operation.

Delete All Images**Delete All Images**

(optional-purchase MMC/SD Card only)

Delete All Images allows you to delete all the images at once from the Screen Snapshot View. This menu option is only available when you have an optional-purchase MMC/SD card installed and you are in Screen Snapshot View.

To delete all images:

1. From the Screen Snapshot View, highlight Delete All Images on the Screen Snapshot X-Press™ Menu.
2. A confirmation dialog box will ask if you want to delete all images. Select Yes to delete, or No to change your mind.



Navigation Menu Tab

Current Track
Saved Tracks
Waypoints
Routes
Chart Orientation North-Up
North Reference True
Grid Rotation 0°
Trackpoint Interval 1 second
Track Min Distance 16ft
Track Color Range 50ft
Map Datum WGS 84 <Default>
Course Projection Line Visible
Export All Nav Data
Delete All Nav Data
Continuous Navigation Mode Off

Press the MENU key twice to access the Main Menu System, then press the RIGHT cursor key to select the Navigation tab.

NOTE: Menu choices will vary depending on system settings.

Navigation Menu Tab

Current Track allows you to view the Current Track submenu.

To view the Current Track Submenu:

1. Highlight Current Track on the Navigation main menu.
2. Use the RIGHT 4-WAY Cursor Control keys to view the Current Track submenu.

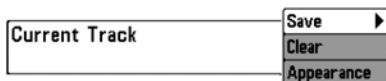

Current Track Submenu

The Current Track Submenu contains the following menu choices:

Save Current Track allows you to save the current track.

Clear Current Track allows you to clear the current track.

Appearance allows you to change the style and color of the current track. (Breadcrumb Trail, Dashed Line, Solid Line or Wide Line, and if a line, the color of the line, or Color By Depth. If you choose Color By Depth, you cannot choose one color to represent the track; a color range will represent the different depths on the track instead, from light green (shallowest) to black (deepest). You can change the depth range associated with black by using Track Color Range menu setting (see *Navigation Main Menu: Track Color Range*).

Saved Tracks allows you to view the Saved Tracks submenu.

To view the Saved Tracks Submenu:

1. Highlight Saved Tracks on the Navigation main menu.
2. Use the RIGHT 4-WAY Cursor Control keys to view the Saved Tracks submenu.

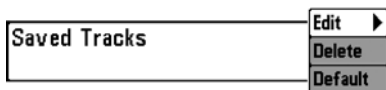

Saved Tracks Submenu

The Saved Tracks Submenu contains the following menu choices:

Edit allows you to select a previously-saved track and edit its name, whether it is visible or not, and its appearance.

Delete allows you to delete a track from a list of previously-saved tracks.

Default sets the appearance of the track created by selecting Save Current Track.

Waypoints allows you to view the Waypoints submenu.

To view the Waypoints Submenu:

1. Highlight Waypoints on the Navigation main menu.
2. Use the RIGHT 4-WAY Cursor Control keys to view the Waypoints submenu.

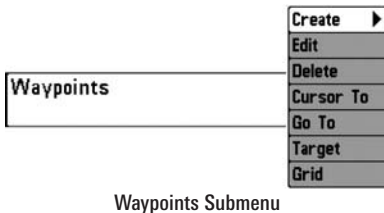

The Waypoints Submenu contains the following menu choices:

Create allows you to create a new waypoint and edit it immediately. The current boat position will be used as the default, but you can set the coordinates to any valid position. The Icon used to represent the waypoint in the Chart Views can also be changed.

Edit allows you to choose from a list of previously-saved waypoints, then edit the Name, Position (Latitude and Longitude) and select the Icon that will be used to represent the waypoint in the Chart Views.

Delete allows you to delete a waypoint from the list of saved waypoints.

Cursor To allows you to move the cursor quickly to a waypoint selected from the list of saved waypoints.

Go To allows you to select a waypoint and start navigation toward that waypoint, or add that waypoint to the end of the current route.

Target allows you to apply a target to a waypoint selected from the list of waypoints.

Grid allows you to apply a trolling grid to a waypoint selected from the list of waypoints.

Routes allows you to view the Routes submenu.

To view the Routes Submenu:

1. Highlight Routes on the Navigation main menu.
2. Use the RIGHT 4-WAY Cursor Control keys to view the Routes submenu.

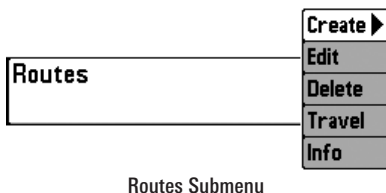

The Routes Submenu contains the following menu choices:

Create allows you to create a new, empty route and add waypoints to it immediately.

Edit allows you to select a previously-saved route and edit its name and the waypoints on it.

Delete allows you to delete a route from a list of previously-saved routes.

Travel allows you to select a previously-saved route to use as the current route; this menu setting also begins navigation on this route. Routes can be traveled in either the forward or reverse direction.

Info displays information about the route, including the distance and bearing from each waypoint to the next.

Chart Orientation



Chart Orientation

Chart Orientation allows you to select whether the Chart Views should be drawn North-Up or Course-Up.

To change the Chart Orientation setting:

1. Highlight Chart Orientation on the Navigation main menu.
2. Use the LEFT or RIGHT 4-WAY Cursor Control keys to change the Chart Orientation setting. (North-Up, Course-Up, Default = North-Up)

NOTE: The Chart Orientation setting does not apply to the Bird's Eye View.

North Reference



North Reference

North Reference allows you to have bearings displayed with one of two orientations: True North or Magnetic North.

To change the North Reference setting:

1. Highlight North Reference on the Navigation main menu.
2. Use the LEFT or RIGHT 4-WAY Cursor Control keys to change the North Reference setting. (True, Magnetic, Default = True)

Grid Rotation

0°



Grid Rotation

Grid Rotation allows you to set the orientation of the trolling grid in degrees, where a setting of 0° displays a standard North, South, East, West alignment. See *Waypoints* for information on how to set a Grid.

To change the Grid Rotation setting:

1. Highlight Grid Rotation on the Navigation main menu.
2. Use the LEFT or RIGHT 4-WAY Cursor Control keys to change the Grid Rotation setting. (0° to 89°, Default = 0°)

NOTE: This feature may appear as either Trolling Grid Rotation or Grid Rotation, depending on your model.

Trackpoint Interval

15 seconds

Trackpoint Interval

Trackpoint Interval allows you to select the time period between trackpoints. The current track can only contain up to 20,000 trackpoints, so longer time periods cause the track to extend back in time, but will be less detailed.

NOTE: Trackpoint Interval works in conjunction with Track Min. Distance. Both conditions must be met before a trackpoint is added to the current track.

To change the Trackpoint Interval setting:

1. Highlight Trackpoint Interval on the Navigation main menu.
2. Use the LEFT or RIGHT 4-WAY Cursor Control keys to change the Trackpoint Interval setting. (1 second, 5 seconds, 10 seconds, 15 seconds, 30 seconds or 60 seconds, Default = 1 second)

NOTE: During slow travel or drift, setting both Trackpoint Interval and Track Min. Distance to small values will allow you to increase the track resolution.

Track Min Distance 16ft

1 | 300

Track Min. Distance

(Advanced)

Track Min. Distance allows you to set a minimum distance of travel before a trackpoint is added to the track. The Track Min. Distance menu choice is only available when User Mode is set to Advanced (see *Setup Menu Tab: User Mode*).

NOTE: Track Min. Distance works in conjunction with Trackpoint Interval. Both conditions must be met before a trackpoint is added to the current track.

To change the Track Minimum Distance setting:

1. Make sure you are in Advanced User Mode, then highlight Track Min. Distance on the Navigation main menu.
2. Use the LEFT or RIGHT 4-WAY Cursor Control keys to change the Track Min. Distance setting. (1 to 300 feet or 1 to 100 meters [*International Units only*], Default = 16 ft, 5 m)

NOTE: During slow travel or drift, setting both Trackpoint Interval and Track Min. Distance to small values will allow you to increase the track resolution.

Track Color Range50  3000

Track Color Range

Track Color Range allows you to set the depth range that will be displayed as black, the deepest depth, when Color By Depth is selected as the style for the current track (see *Navigation Menu Tab: Current Track*).

To change the Track Color Range:

1. Highlight Track Color Range on the Navigation main menu.
2. Use the LEFT or RIGHT 4-WAY Cursor Control keys to change the Track Color Range setting. (50 to 3000 feet or 20 to 1000 meters [*International Units only*], Default = 50 ft, 15 m)

Map Datum WGS 84 <Default>

Map Datum

(Advanced)

Map Datum allows you to change the map coordinate system used by the Chartplotter to match those of a paper map. The Map Datum menu choice is only available when User Mode is set to Advanced (see *Setup Menu Tab: User Mode*).

To change the Map Datum setting:

1. Make sure you are in Advanced User Mode, then highlight Map Datum on the Navigation main menu.
2. Use the LEFT or RIGHT 4-WAY Cursor Control keys to change the Map Datum setting. (Default = WGS 84)

Course Projection Line

Visible

Course Projection Line

Course Projection Line allows you to display or hide an arrow extending from the bow of the boat that projects your current course, and shows where the boat will go if you continue on your present course.

To change the Course Project Line setting:

1. Highlight Course Projection Line on the Navigation main menu.
2. Use the LEFT or RIGHT 4-WAY Cursor Control keys to change the Course Projection Line setting (Hidden, Visible, Default = Visible)

Export All Nav Data



Export All Nav Data

(Advanced)

Export All Nav Data allows you to export all saved Tracks, Waypoints and Routes to an MMC/SD card. The Export All Nav Data menu choice is only available when User Mode is set to Advanced (see *Setup Menu Tab: User Mode*).

To Export All Navigation Data:

1. Make sure you are in Advanced User Mode, and that an optional-purchase MMC/SD card is installed in the slot, then highlight Export All Nav Data on the Navigation main menu.
2. Use the RIGHT 4-WAY Cursor Control key to export all navigation data. A confirmation dialog box will appear to allow you to change your mind, and to confirm your choice. If no MMC/SD card is installed, and error message will be displayed. Insert the MMC/SD card and try again.

Delete All Nav Data



Delete All Nav Data

(Advanced)

Delete All Nav Data allows you to delete all saved Tracks, Waypoints and Routes. This menu choice should be used with caution. The Delete All Nav Data menu choice is only available when User Mode is set to Advanced (see *Setup Menu Tab: User Mode*).

To Delete All Navigation Data:

1. Make sure you are in Advanced User Mode, then highlight Delete All Nav Data on the Navigation main menu.
2. Use the RIGHT 4-WAY Cursor Control key to delete all navigation data. A confirmation dialog box will appear to allow you to change your mind, or to confirm your choice.

Continuous Navigation Mode



Continuous Navigation Mode

Continuous Navigation Mode allows you to continue to navigate and fish around a particular waypoint, even if you pass over it multiple times.

To activate or de-activate Continuous Navigation::

1. Highlight Continuous Navigation Mode on the Navigation main menu.
2. Use the LEFT or RIGHT 4-WAY Cursor Control keys to turn Continuous Navigation Mode On or Off (Off, On, Default = Off)

Chart	
Chart Detail Level	All
Map Borders	MMC/SD Only
Lat/Lon Grid	Hidden
Spot Soundings	Visible
Nav aids on Bird's Eye View	Visible
Shaded Depth	15ft
Set Simulation Position	
Set Map Offset	
Clear Map Offset	

Chart Menu

Chart Menu Tab

Press the MENU key twice to access the Main Menu System and then press the RIGHT Cursor key to select the Chart tab.

NOTE: Menu choices will vary depending on system settings such as whether the unit is set for Advanced User mode.

Chart Detail Level

Chart Detail Level allows you to select how much chart detail you want displayed on the Navigation Views. **Basic** shows land areas, ports, obstructions and restricted areas. **Navigation** shows nav aids, landmarks, ferryways and navigation routes in addition to the Basic information. **Underwater** shows depth contours, fishing areas, underwater wrecks, tides and currents in addition to the Basic and Navigation information. **All** shows roads, buildings, railways, and other notations in addition to the Basic, Navigation and Underwater information.

To change the Chart Detail Level setting:

1. Highlight Chart Detail Level on the Chart main menu.
2. Use the LEFT or RIGHT 4-WAY Cursor Control keys to change the Chart Detail Level setting. (Basic, Navigation, Underwater, All, Default = All)

***NOTE:** Some chart details are only available with optional-purchase MMC/SD cards.*

Map Borders

Hidden

Map Borders

Map Borders allows you to display or hide map borders. A Map Border indicates an area which contains a different map.

Map Borders

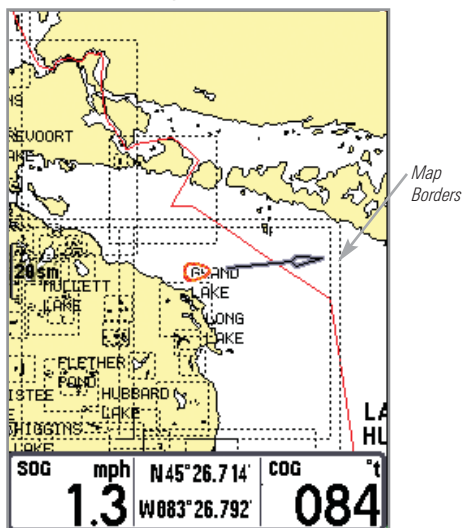

To change the Map Borders setting:

1. Highlight Map Borders on the Chart main menu.
2. Use the LEFT or RIGHT 4-WAY Cursor Control keys to change the Map Borders setting. (Hidden, MMC/SD Only, All Visible, Default = MMC/SD Only)

Lat/Lon Grid

◀ Hidden ▶

Lat/Lon Grid

Lat/Lon Grid allows you to display or hide a grid showing latitude and longitude lines.

To change the Lat/Lon Grid setting:

1. Highlight Lat/Lon Grid on the Chart main menu.
2. Use the LEFT or RIGHT 4-WAY Cursor Control keys to change the Lat/Lon Grid setting. (Hidden, Visible, Default = Hidden)

Spot Soundings

◀ Hidden ▶

Spot Soundings

Spot Soundings allows you to display or hide spot soundings, which are depth measurements shown on the chart.

NOTE: Spot Soundings are only available with optional-purchase MMC/SD cards.

To change the Spot Soundings setting:

1. Highlight Spot Soundings on the Chart main menu.
2. Use the LEFT or RIGHT 4-WAY Cursor Control keys to change the Spot Soundings setting. (Hidden, Visible, Default = Visible)

Nav aids on Bird's Eye View

◀ Hidden ▶

Nav aids on Bird's Eye View

Nav aids on Bird's Eye View allows you to display or hide additional navigational aids, such as lights and buoys, in Bird's Eye View.

NOTE: You will see more navigational aids with and optional-purchase MMC/SD card.

To change the Nav aids on Bird's Eye View setting:

1. Highlight Nav aids on Bird's Eye View on the Chart main menu.
2. Use the LEFT or RIGHT 4-WAY Cursor Control keys to change the Nav aids on Bird's Eye View setting. (Hidden, Visible, Default = Visible)



Shaded Depth

Shaded Depth allows you to change the depth used for shading on the chart views.

To change the Shaded Depth setting:

1. Highlight Shaded Depth on the Navigation main menu.
2. Use the LEFT or RIGHT 4-WAY Cursor Control keys to change the Shaded Depth setting. (Off, 1 to 60 Feet or 1 to 20 Meters [*International Units only*], Default = 15 ft, 5 m)



Set Simulation Position

(*Advanced*)

Set Simulation Position allows you to set the position of the boat used in the Simulator. The Set Simulation Position menu choice is only available when User Mode is set to Advanced (see *Setup Menu Tab: User Mode*).

To set the Simulation Position:

1. Activate the cursor and move it to the coordinates from where you want the simulation to start.

NOTE: *The cursor must be active in order for this procedure to work.*

2. Make sure you are in Advanced User Mode, then highlight Set Simulation Position on the Chart main menu.
3. Use the RIGHT 4-WAY Cursor Control key to change the Simulation Position setting. A confirmation dialog box will appear to allow you to change your mind, or to confirm your choice. If the cursor was not active before you began this procedure, you will see an error message. Exit the menu, set the cursor, then try again.

Set Map Offset allows you to change the map offset used by your Chartplotter. The Set Map Offset menu choice is only available when User Mode is set to Advanced (see *Setup Menu Tab: User Mode*).

NOTE: The Map Offset will be applied to all maps and not just the map that requires the correction. The Map Offset should be cleared if a different map is to be used.

To change the Map Offset setting:

1. Activate the cursor and move it to the location where the Map Offset will be applied.

NOTE: The cursor must be active in order for this procedure to work.

2. Make sure you are in Advanced User Mode, then highlight Set Map Offset on the Chart main menu.
3. Use the RIGHT 4-WAY Cursor Control key to set the Map Offset. A confirmation dialog box will appear to allow you to change your mind, or to confirm your choice. If the cursor was not active before you began this procedure, you will see an error message. Exit the menu, set the cursor, then try again.

Clear Map Offset allows you to clear the Map Offset. The Clear map Offset menu choice is only available when User Mode is set to Advanced (see *Setup Menu Tab: User Mode*) and a Map Offset is currently active.

To Clear Map Offset:

1. Make sure you are in Advanced User Mode, then highlight Clear Map Offset on the Chart main menu.
2. Use the RIGHT 4-WAY Cursor Control key to clear the Map Offset.

Alarms	
Low Battery Alarm	Off
Aux. Temp. Alarm	Off
Temp. Alarm	Off
Off Course Alarm	600ft
Arrival Alarm	Off
Drift Alarm	Off
Alarm Tone	Medium

Alarms Menu

Alarms Menu Tab

From any view, press the MENU key twice to access the Main Menu System. The Alarms tab will be the default selection.

NOTE: When an alarm is triggered, you can silence it by pressing any key. The alarm will be silenced, and will not be triggered again until a new instance of the alarm condition is detected.

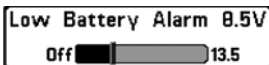

Low Battery Alarm

Low Battery Alarm sounds when the input battery voltage is equal to or less than the menu setting. The battery alarm will only sound for the battery that is connected to the Chartplotter. The Low Battery Alarm should be set to warn you when the battery voltage drops below the safety margin that you have determined. For instance, if you are running a trolling motor (battery operated), you would want to set the Low Battery Alarm to sound before the battery voltage drops too low for it to be used to start your main, gasoline-powered engine.

To change the Low Battery Alarm setting:

1. Highlight Low Battery Alarm on the Alarms main menu.
2. Use the LEFT or RIGHT 4-WAY Cursor Control keys to change the Low Battery Alarm setting. (Off, 8.5V - 13.5V, Default = Off)

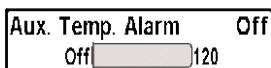

Aux. Temp. Alarm

(with optional-purchase temp. probe or Temp/Speed only)

Aux. Temp. Alarm sounds when the water temperature from the Paddlewheel/Temperature Probe detected by the Chartplotter reaches the Aux. Temp. Alarm setting, which is either set in degrees Fahrenheit or Celsius [*International Models only*]. For example, if the Aux. Temp. Alarm is set to 58 degrees Fahrenheit, and the water temperature falls from 60 degrees to 58 degrees, the Aux. Temp. Alarm will sound. Similarly, if the water temperature rises from 56 degrees to 58 degrees, the Aux. Temp. Alarm will also sound.

To change the Aux. Temp. Alarm setting:

1. Highlight Aux. Temp. Alarm on the Alarms main menu.
2. Use the LEFT or RIGHT 4-Way Cursor Control keys to change the Aux. Temp. Alarm setting. (Off, 33-120 [Fahrenheit], 0-50 [Celsius], Default = Off)

Temp. Alarm Off
 Off  58

Temp. Alarm

Temp. Alarm sounds when the water temperature detected by the Chartplotter reaches the Temp. Alarm setting, which is either set in degrees Fahrenheit or Celsius [*International Models only*]. For example, if the Temp. Alarm is set to 58 degrees Fahrenheit, and the water temperature falls from 60 degrees to 58 degrees, the Temp. Alarm will sound. Similarly, if the water temperature rises from 56 degrees to 58 degrees, the Temp. Alarm will also sound.

To change the Temp. Alarm setting:

1. Highlight Temp. Alarm on the Alarms main menu.
2. Use the LEFT or RIGHT 4-Way Cursor Control keys to change the Temp. Alarm setting. (Off, 33-120 [Fahrenheit], 0-50 [Celsius], Default = Off)

Off Course Alarm 300ft
 Off  3000

Off Course Alarm

Off Course Alarm sounds when the boat has moved too far off course based on the menu setting when navigating. Off Course Alarm allows you to set how far the boat is allowed to move off course before the Off Course Alarm will sound.

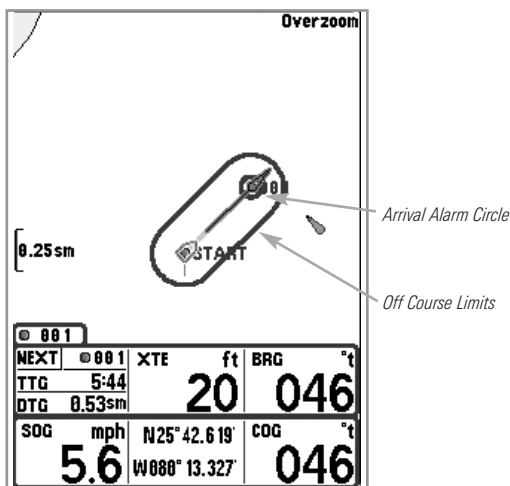

To change the Off Course Alarm setting:

1. Highlight Off Course Alarm on the Alarms main menu.
2. Use the LEFT or RIGHT 4-WAY Cursor Control keys to change the Off Course Alarm setting. (Off, 25 to 3000 feet, 10 to 1000 meters [*International Models only*], Default = 300 ft, 100 m)



Arrival Alarm

Arrival Alarm sounds when the boat has either exceeded the distance to the destination waypoint, or has entered the Arrival Alarm Circle, based on the menu setting when navigating. Arrival Alarm allows you to set how close the boat must be to the destination waypoint before the Arrival Alarm will sound.

To change the Arrival Alarm setting:

1. Highlight Arrival Alarm on the Alarms main menu.
2. Use the LEFT or RIGHT 4-WAY Cursor Control keys to change the Arrival Alarm setting. (Off, 25 to 3000 feet, 10 to 1000 meters [*International Models only*], Default = 150 ft, 50 m)

Drift Alarm Off
Off 3000

Drift Alarm

Drift Alarm sounds when the boat has exceeded the distance from the boat's anchored position, based on the menu setting. Drift Alarm allows you to set the size of a perimeter around the boat's anchored position; if the anchored boat drifts outside of that perimeter, the Drift Alarm will sound.

Drift Alarm Perimeter

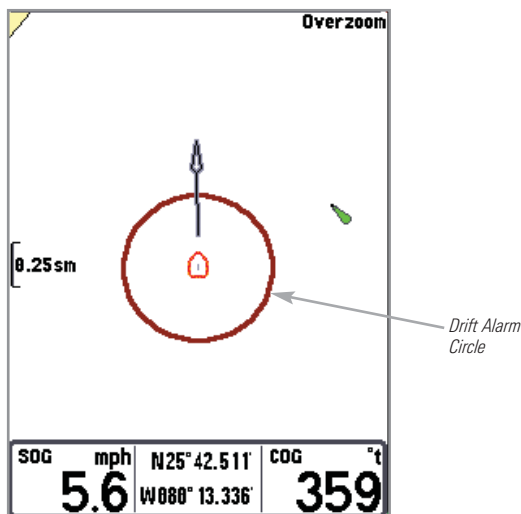

To change the Drift Alarm setting:

1. Highlight Drift Alarm on the Alarms main menu.
2. Use the LEFT or RIGHT 4-WAY Cursor Control keys to change the Drift Alarm setting. (Off, 25 to 3000 feet, 10 to 1000 meters [*International Models only*], Default = Off)

Alarm Tone

◀ Medium ▶

Alarm Tone

Alarm Tone selects the pitch of the alarm sound.

A brief tone will be produced as you adjust the Alarm Tone so that you can select the tone that you can hear best.

To change the Alarm Tone setting:

1. Highlight Alarm Tone on the Alarms main menu.
2. Use the LEFT or RIGHT 4-WAY Cursor Control keys to change the Alarm Tone setting. (High, Medium, Low, Default = Medium)

Setup	
Units - Depth	Feet
Units - Temp	°f
Units - Distance	Statute Miles
Units - Speed	mph
User Mode	Advanced
Triplog Reset	
Restore Defaults	
Aux. Temp. Offset	0.0°
Temp. Offset	0.0°
Speed Calibration	0%
Local Time Zone	EST <UTC-5>
Daylight Saving Time	Off
Position Format	dd°mm.mmm'
Time Format	12-hour
Date Format	mm/dd/yy
Digits Format	Large tenths
NMEA Output	Off
Demonstration	Off

Setup Menu Tab

From any view, press the MENU key twice to access the tabbed Main Menu System, then press the RIGHT cursor key until the Setup tab is selected.

NOTE: Menu choices will vary depending on system settings such as whether the unit is set for Advanced User mode and what accessories are attached to the unit.

Setup Menu Tab

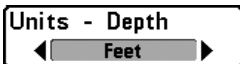

Units - Depth

Units - Depth selects the units of measure for all depth-related readouts.

To change the Units - Depth setting:

1. Highlight Units - Depth on the Setup menu.
2. Use the LEFT or RIGHT 4-WAY Cursor Control keys to change the Units - Depth setting. (Meters [*International Models only*], Feet, Fathoms; Default is Meters for International models, and Feet for Domestic models)

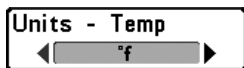

Units - Temp.

(*International only*)

Units - Temp. selects the units of measure for all temperature-related readouts. *International Models only.*

To change the Units - Temp. setting:

1. Highlight Units - Temp. on the Setup menu.
2. Use the LEFT or RIGHT 4-WAY Cursor Control keys to change the Units - Temp. setting. (Celsius, Fahrenheit; Default = Celsius)

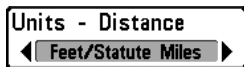

Units - Distance

Units - Distance selects the units of measure for all distance-related readouts, and will appear in the menu if a Temp/Speed Accessory is connected and the paddlewheel has moved at least once, or if the GPS Receiver is connected.

To change the Units - Distance setting:

1. Highlight Units - Distance on the Setup menu.
2. Use the LEFT or RIGHT 4-WAY Cursor Control keys to change the Units - Distance setting. (Domestic Models: Statute Miles, Nautical Miles; Default = Statute Miles; International Models: Meters/Kilometers, Meters/Nautical Miles, Feet/Statute Miles, Feet/Nautical Miles; Default = Meters/Kilometers)

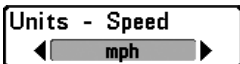

Units - Speed

Units - Speed selects the units of measure for speed-related readouts, and will appear in the menu if a Temp/Speed Accessory is connected and the paddlewheel has moved at least once, or if the GPS Receiver is connected.

To change the Units - Speed setting:

1. Highlight Units - Speed on the Setup menu.
2. Use the LEFT or RIGHT 4-WAY Cursor Control keys to change the Units - Speed setting. (kph [*International Models only*], mph, kts, Default = kph for International models and mph for Domestic models)

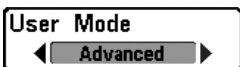

User Mode

User Mode sets the menu system to either Normal or Advanced. When set to Normal (default setting,) only the basic menu options are shown. When set to Advanced, additional menu choices are available.

To change the User Mode setting:

1. Highlight User Mode on the Setup menu.
2. Use the LEFT or RIGHT 4-WAY Cursor Control keys to change the User Mode setting. (Normal, Advanced, Default = Advanced)

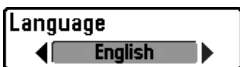

Language

(*International only*)

Language selects the display language for menus. *International Models only.*

To change the Language setting:

1. Highlight Language on the Setup menu.
2. Use the LEFT or RIGHT 4-WAY Cursor Control keys to change the Language setting. (Default = English)

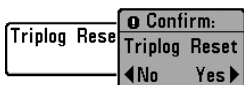

Triplog Reset

Triplog Reset resets the Triplog to zero, and will appear in the menu if a Temp/Speed Accessory is connected and the paddlewheel has moved at least once, or if the GPS Receiver is connected. The Triplog provides the following information: timer for elapsed time, distance traveled since last reset, and average speed.

*NOTE: See **Setup Menu Tab: Select Readouts** to find out how to display Triplog information on the screen.*

To Reset Triplog:

1. Highlight Reset Triplog on the Setup menu.
2. Use the RIGHT 4-WAY Cursor Control key to initiate Triplog Reset.
3. The Confirm dialog box will appear. To reset the Triplog, press the RIGHT Cursor key once more. To cancel Reset Triplog, press the LEFT Cursor key.

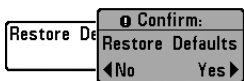

Restore Defaults

Restore Defaults resets ALL menu settings to their factory defaults. Use this menu choice with caution!

To Restore Defaults:

1. Highlight Restore Defaults on the Setup menu.
2. Use the RIGHT 4-WAY Cursor Control key to initiate restoring defaults.
3. The Confirm dialog box will appear. To reset the defaults, press the RIGHT Cursor key once more. To cancel Restore Defaults, press the LEFT Cursor key.

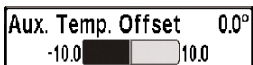

Aux. Temp. Offset

(Advanced)

Aux. Temp. Offset will adjust the aux. temperature readout (the temperature on the optional-purchase temperature probe or Temp/Speed accessory) by the amount entered. This menu choice is available only when in Advanced User Mode (see *Setup Menu Tab: User Mode.*)

To change the Aux. Temp. Offset setting:

1. Make sure you are in Advanced User Mode, then highlight Aux. Temp. Offset on the Setup menu.
2. Use the LEFT or RIGHT 4-WAY Cursor Control keys to change the Aux. Temp. Offset setting. (-10.0 to +10.0 degrees, Default = 0)



Temp. Offset

(Advanced)

Temp. Offset will adjust the temperature readout by the amount entered. This menu choice is available only when in Advanced User Mode (see *Setup Menu Tab: User Mode.*)

To change the Temp. Offset setting:

1. Make sure you are in Advanced User Mode, then highlight Temp. Offset on the Setup menu.
2. Use the LEFT or RIGHT 4-WAY Cursor Control keys to change the Temp. Offset setting. (-10.0 to +10.0 degrees, Default = 0)



Speed Calibration

(Advanced, with Temp/Speed only)

Speed Calibration will adjust the speed readout by the percentage entered, and will appear in the menu if a Temp/Speed Accessory is connected and the paddlewheel has moved at least once, when the unit is in Advanced User Mode (see *Setup Menu Tab: User Mode*.)

To change the Speed Calibration setting:

1. Make sure you are in Advanced User Mode, then highlight Speed Calibration on the Setup menu.
2. Use the LEFT or RIGHT 4-WAY Cursor Control keys to change the Speed Calibration setting. (-20% to +20%, Default = 0%)



Local Time Zone

(Advanced)

Local Time Zone selects your time zone in reference to the time reported by the GPS receiver when Time+Date is selected as a Digital Readout (see *Select Readouts*). This menu choice is available only when in Advanced User Mode (see *Setup Menu Tab: User Mode*).

To change the Local Time Zone:

1. Make sure you are in Advanced User Mode, then highlight Local Time Zone on the Setup menu.
2. Use the LEFT or RIGHT 4-WAY Cursor Control keys to change the Local Time Zone (Default = EST [UTC-5] - Eastern Standard Time).

Daylight Saving Time

Off

Daylight Saving Time

(Advanced)

Daylight Saving Time adjusts the time display to account for local Daylight Saving Time when Time+Date is selected as a Digital Readout (see *Select Readouts*). Selecting On adds one hour to the time display adjusted for your local time zone. Selecting Off leaves the time display as adjusted for your local time zone. This menu choice is available only when in Advanced User Mode (see *Setup Menu Tab: User Mode*).

To change the Daylight Saving Time setting:

1. Make sure you are in Advanced User Mode, then highlight Daylight Saving Time on the Setup menu.
2. Use the LEFT or RIGHT 4-WAY Cursor Control keys to turn Daylight Saving Time On or Off. (Off, On, Default = Off)

Position Format

dd°mm.mmm'

Position Format

(Advanced)

Position Format selects the format of the latitude and longitude position display. This menu choice is available only when in Advanced User Mode (see *Setup Menu Tab: User Mode*).

To change the Position Format setting:

1. Make sure you are in Advanced User Mode, then highlight Position Format on the Setup menu.
2. Use the LEFT or RIGHT 4-WAY Cursor Control keys to change the Position Format. (dd.ddddd°, dd°mm.mmm', or dd°mm'ss", Default = dd°mm.mmm')



Time Format

(Advanced, International only)

Time Format changes the time format used by the unit. This menu choice is available only when in Advanced User Mode (see *Setup Menu Tab: User Mode*). *International Models only*. Time Format selects a 12 hour or 24 hour format for the time of day displayed when Time + Date is selected as a Digital Readout (see *Select Readouts*).

To change the Time Format:

1. Make sure you are in Advanced User Mode, then highlight Time Format on the Setup menu.
2. Use the LEFT or RIGHT 4-WAY Cursor Control keys to change the Time Format. (12 hour, 24 hour, Default = 12 hour)



Date Format

(Advanced, International only)

Date Format changes the date format used by the unit. This menu choice is available only when in Advanced User Mode (see *Setup Menu Tab: User Mode*). *International Models only*. Date Format selects the format for the date display when Time + Date is selected as a Digital Readout (see *Select Readouts*).

To change the Date Format:

1. Make sure you are in Advanced User Mode, then highlight Date Format on the Setup menu.
2. Use the LEFT or RIGHT 4-WAY Cursor Control keys to change the Date Format. (mm/dd/yy, dd.mm.yy or yy.mm.dd, Default = mm/dd/yy)

Digits Format

◀ Small tenths ▶

Digits Format*(Advanced)*

Digits Format allows you to add a tenth decimal place to readouts such as Temperature and Depth. The format can be changed to small format, large format or no format. This menu choice is available only when in Advanced User Mode (see *Setup Menu Tab: User Mode.*)

To change the Digits Format setting:

1. Make sure you are in Advanced User Mode, then highlight Digits Format on the Setup menu.
2. Use the LEFT or RIGHT 4-WAY Cursor Control keys to change the Digits Format setting. (Small tenths, Large tenths, No tenths, Default = Large tenths)

NOTE: Choosing No tenths will cause the display to present numbers rounded to whole digits only.

NMEA Output

◀ Off ▶

NMEA Output*(Advanced)*

NMEA Output turns the NMEA* output on or off. This menu choice is available only when in Advanced User Mode (see *Setup Menu Tab: User Mode.*) NMEA Output should be turned On if you connect the NMEA Output wires of the GPS Receiver cable to another NMEA-compatible device, such as an autopilot.

**NMEA 0183 is a National Marine Electronics Association standard for data communication.*

The following NMEA sentences are output when NMEA Output is turned On:

DPT- Depth

MTW - Water Temperature

GLL - Lat/Lon Position

GGA - GPS Fix Data

RMC - Recommended Minimum Specific GNSS Data

VTG - Course Over Ground and Ground Speed

ZDA - Time and Date

When navigating, the following NMEA sentences are also output when NMEA Output is turned On:

APB - Autopilot Sentence B

BWR - Bearing and Distance to Waypoint

RMB - Recommended Minimum Navigation Info

To turn NMEA Output on or off:

1. Make sure you are in Advanced User Mode, then highlight NMEA Output on the Setup menu.
2. Use the LEFT or RIGHT 4-WAY Cursor Control keys to change the NMEA Output to On or Off (Off, On, Default = Off).

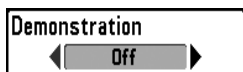

Demonstration

Demonstration deactivates the Demonstration Mode feature (see *Powering Up the Unit*).

To turn Demonstration on or off:

1. Highlight Demonstration on the Setup menu.
2. Use the LEFT or RIGHT 4-WAY Cursor Control keys to turn Demonstration On or Off (Off, On, Default = On).

Views	
Bird's Eye No Readouts View	Hidden
Bird's Eye View	Visible
Bird's Eye Big Digits View	Visible
Chart No Readouts View	Visible
Chart View	Visible
Chart Big Digits View	Visible
Instrument View	Visible
Screen Snapshot	Hidden
Self Test	Hidden
Accessory Test	Hidden
GPS Diagnostic View	Visible

Views Menu

Views Menu Tab

From any view, press the MENU key twice to access the tabbed Main Menu System, then press the RIGHT 4-WAY Cursor Control key until the Views tab is selected. This menu tab allows you to set the available views to either hidden or visible in the view rotation. The view will be removed from the view rotation if it is set to Hidden and will be displayed in the view rotation if it is set to Visible. The following views are available:

- Bird's Eye No Readouts View
- Bird's Eye View
- Bird's Eye Big Digits View
- Chart No Readouts View
- Chart View
- Chart Big Digits View
- Instrument View
- Screen Snapshot View
- Self Test
- Accessory Test
- GPS Diagnostic View.

To Change the View Status of Any View:

1. Highlight the View main menu tab.
2. Use the UP or DOWN 4-WAY Cursor Control keys to select a View.
3. Use the LEFT or RIGHT 4-WAY Cursor Control keys to change the status of the view from Hidden to Visible.

Accessories Menu Tab

From any view, press the MENU key twice to access the tabbed Main Menu System, then press the RIGHT cursor key until the Accessories tab is selected.

If no accessories are attached to the Accessory Bus, no accessory menu choices will appear under the Accessories tab, only the Screen Snapshot menu choice. If an accessory is attached, however, additional menu choices that support the accessory will be added automatically. See the Operations Manual that comes with your accessory for detailed information.



Accessories Menu Tab
(no accessories attached)



Accessories Menu Tab
(with accessories attached)

NOTE: Accessories to enable WeatherSense® and the SmartCast® Wireless Sonar Link require separate purchases. You can visit our website at www.humminbird.com or contact our Customer Resource Center at **1-800-633-1468** for additional details.



Using Screen Snapshot

Screen Snapshot activates the screen snapshot function. When Screen Snapshot is enabled, pressing the MARK key creates a saved screen capture on the optional-purchase MMC/SD card installed in your unit's card slot. All menus, dialog boxes, warnings and messages are captured and saved automatically.

Once you have created a screen capture, a screen capture thumbnail is added to the Screen Snapshot View, and is available to view at a later date. See the full-sized image by highlighting a thumbnail (using the Up or Down 4-Way Cursor keys), then using the Right 4-Way Cursor key to view the full image. A border around the full-size screen snapshot indicates that it is just a screen snapshot, not a "live" view. You can delete the highlighted image, or all images, by selecting a thumbnail and using Delete Image, or using Delete All Images from the Screen Snapshot X-Press™ menu. You can view these captures on the Screen Snapshot View, which shows any existing thumbnails of the screen captures.

NOTE: You must have an optional-purchase MMC/SD card installed for the Screen Snapshot feature to work.

NOTE: If you use your MMC/SD card in two different control heads that have different screen sizes, the Screen Snapshot made on one unit will still be present on the card, but will be represented by the Unavailable icon (circle with a slanted line through it) on the Screen Snapshot View on the other unit.

To turn Screen Snapshot on or off:

1. Highlight Screen Snapshot on the Accessories main menu.
2. Use the LEFT or RIGHT 4-WAY Cursor Control keys to turn Screen Snapshot On or Off (Off, On, Default = Off).

To make a screen snapshot (Screen Snapshot must be enabled):

1. Make sure you have installed an optional-purchase MMC/SD card into your card slot.
2. From any view you want to capture, press the MARK key. When you start a screen capture, you will see a message that a waypoint has been created at the point where your cursor is on the screen, and the screen will freeze while the snapshot is being saved to the MMC/SD

card. A status dialog box will appear that shows the progress of the save as a percentage, and that displays the numbered file name assigned to the .BMP file that is being created.

NOTE: For more information, see *Screen Snapshot View* and *Screen Snapshot X-Press™ Menu*.

NOTE: Navigation is not affected by the Screen Snapshot feature. Also, if Screen Snapshot is enabled but there is no GPS receiver connected, pressing the MARK key will capture the screen image and display an error saying that a GPS position fix is required to create a waypoint.

NOTE: The speed of the capture depends on the type of card you use; in general, SD cards capture the screen faster than MMC cards do.

To view screen snapshots:

1. Make sure that the optional-purchase MMC/SD card used to capture the screen is installed in your card slot.
2. Press the VIEW key until you see the Screen Snapshot View.
3. You can scroll through the whole list of captures in this view using the 4-WAY Cursor keys. Highlight a thumbnail (using the Up or Down 4-Way Cursor keys), then use the Right 4-Way Cursor key to view the full image. A border around the full-size screen capture indicates that it is just a screen capture, not a “live” view. You can delete the highlighted image, or all captured images, using the Snapshot X-Press™ menu. (See *Screen Snapshot X-Press™ menu: Delete Image and Delete All Images* for more information).

NOTE: When you highlight a snapshot thumbnail, the amount of room remaining on the SD card will be displayed.

NOTE: The waypoints that are created by a snapshot have the same name as the file and use a custom waypoint icon. Screen Snapshot filenames begin with the letter “S”.

NOTE: You may view data files associated with each screen snapshot by removing the MMC/SD card from your unit and installing it in your optional-purchase MMC/SD card reader connected to a PC. Use Windows Explorer to see the contents of your MMC/SD card; you will notice that a .DAT (may show up as .TXT) file is created for every .BMP screen capture; this data file includes the thumbnail view, and is required in order to be able to view the screen snapshot from your unit, so don't delete these files.

Troubleshooting

Before contacting the Humminbird® Customer Resource Center, please read the following section. Taking the time to review these troubleshooting guidelines may allow you to solve a performance problem yourself, and therefore avoid sending your unit back for repair.

Chartplotter Doesn't Power Up

If your Chartplotter doesn't power up, use the Installation Guide that also comes with it for specific confirmation details, making sure that:

- The power cable is properly connected to the Chartplotter control head.
- The power cable is wired correctly, with red to positive battery terminal and black to negative terminal or ground.
- The fuse is operational.
- The battery voltage of the power connector is at least 10 Volts.

Correct any known problems, including removing corrosion from the battery terminals or wiring, or actually replacing the battery if necessary.

Display Problems

There are several main conditions or sources of possible interference that may cause problems with the quality of the information displayed on the control head. Look in the following table for some symptoms of display problems and possible solutions:

Problem	Possible Cause
The control head loses power at high speeds.	If the power output of your boat's engine is unregulated, the control head may be protecting itself using its over-voltage protection feature. Make sure the input voltage does not exceed 20 Volts.

Finding the Cause of Noise

Electrical noise usually affects the display with many black dots at high speeds, and high sensitivity readings. One or more of the following sources can cause noise or interference:

Possible Source of Noise	Isolation
Other electronic devices	Turn off any nearby electronic devices to see if the problem goes away, then turn them on one at a time to see if the noise re-appears.
The boat's engine	To determine whether the boat's engine is the source of the noise, increase the RPMs while the boat is in neutral and stationary to see if the noise increases proportionately; if noise appears when you rev the engine, the problem could be the spark plugs, alternator, or tachometer wiring. Replace the spark plugs with resistor plugs, install an alternator filter, or route the control head power and transducer cables away from the engine wiring.

700 Series™ Chartplotter Accessories

Accessories customize the 700 Series™ Chartplotter to your needs and enable you to stay on the edge of new technology. When an accessory is connected to the 700 Series™ Chartplotter, additional menus and readouts are added automatically to the Main Menu System. Accessories available today that are supported by your Chartplotter include:

WeatherSense® Fishing Condition Monitor: purchase and plug in the WeatherSense® accessory to your 700 Series™ Chartplotter to obtain barometric pressure readouts and trend data in real time.

GPS Connection Cable: purchase the GPS Connection Cable in order to connect a handheld or other NMEA* GPS-compatible device that you may already own to your 700 Series™ Chartplotter.

**NMEA 0183 is a National Marine Electronics Association standard for data communication.*

Wireless Sonar Link (WSL) purchase the Wireless Sonar Link (WSL) accessory to receive remote sonar signals from a SmartCast® Remote Sonar Sensor (RSS). Radio signals from the RSS are received by the WSL and transmitted over the Accessory Bus to the 700 Series™ Chartplotter.

PC Connect Cable: Purchase the PC Connect Cable to connect the 700 Series™ Chartplotter to a PC in order to upload product software updates and new features obtained from www.humminbird.com. This accessory requires the MSWindows-compatible HumminbirdPC™ software downloaded from our website to your PC in order to communicate with the 700 Series™ Chartplotter.

Downriggers are the key to catching fish you otherwise couldn't even touch. And now Humminbird's **CannonLink™** Downrigger Controller makes operation of up to six Cannon™ Mag 20 DT or Mag 20 DT/HS downriggers incredibly easy. Using the controls on your Chartplotter, deploy or retrieve downriggers, hold a specific distance off the bottom, cycle downriggers between two depths, and adjust the Positive Ion Control. Even see temperature and water clarity at depth and speed at the ball right on-screen when using the Cannon™ Speed-n-Temp. You'll never be shorthanded again, just make adjustments from the helm, while your mate rigs the lines and brings in the fish!

With the new **InterLink™** Network Connection, you can now share GPS position, waypoints, routes and your current track between two Humminbird® Chartplotters in real time. Mark a waypoint at the console, and it's instantly available on the second unit. No matter where you're at on the boat, you'll have access to your critical fishing and navigation information. Plus, daisy chain **InterLink™** with other System Modules and you'll have a network that lets you share digital data around the boat. It's a simply, clearly, better networking solution!

Be sure to check out our website **www.humminbird.com** for additional new and exciting accessories to grow your 700 Series™ Chartplotter!

***NOTE:** Each accessory requires a separate purchase. You can visit our website at **www.humminbird.com** or contact our Customer Resource Center at **1-800-633-1468** for additional details.*

Specifications

Power Requirement	10-20 VDC
LCD Matrix	320 V x 240 H (755c) 640 V x 480 H (785c ² and 785c ² i)
Current Draw	650 mA

***NOTE:** Product specifications and features are subject to change without notice.*

***POLICY ON ENVIRONMENTAL COMPLIANCE:** It is the intention of Humminbird® to be a good corporate citizen and comply and meet all known and applicable environmental regulations in the areas and countries where our products are sold. We will promote and implement environmentally sound processes in support of national and international regulations.*

***ROHS STATEMENT:** Product designed and intended as a fixed installation or part of a system in a vessel may be considered beyond the scope of Directive 2002/95/EC of the European Parliament and of the Council of 27 January 2003 on the restriction of the use of certain hazardous substances in electrical and electronic equipment.*

***WEEE STATEMENT:** Product designed and intended as a fixed installation or part of a system in a vessel may be considered beyond the scope of Directive 2002/96/EC of the European Parliament and of the Council of 27 January 2003 on waste electrical and electronic equipment (WEEE).*

***CALIFORNIA PROPOSITION 65 STATEMENT:** Lead in cable jackets and boots is restricted to 300 parts per million or less as determined by ICP-AES test methods.*

Glossary

GPS & Navigation Terms:

Acquisition Time: The length of time that a GPS receiver typically takes to determine a position from at least three satellites. Humminbird® GPS receivers provide very fast acquisition times (under one minute), permitting users to get out on the water faster.

Alarm, Arrival: The audible alert that sounds when the boat is equal to or less than the alarm setting (25 feet – 3000 feet) from the location of the destination waypoint.

Alarm, Drift: Drift Alarm is an audible alert that sounds when the boat is equal to or over the alarm setting (25 feet – 3000 feet) from the location where the alarm was turned on.

Alarm, Off-Course: Off-Course Alarm is an audible alert that sounds when the boat's distance from the intended Track, (Cross Track Error), is equal to or over the alarm setting (25 feet – 3000 feet). See *Track* and *Cross Track Error*.

Altitude: Altitude measures height above sea level. Altitude is a measurement that can be provided by GPS.

Bearing (BRG): Bearing is the direction to a destination waypoint measured in degrees from North (i.e. 321°, where 000° is North, 090° East, 180° is South, 270° is West).

Chartplotter: Chartplotter describes a navigation device that shows Present Position on a Map, along with Tracks, Waypoints, and Routes. All Chartplotters are also considered Trackplotters. All Humminbird® GPS Combo units are Chartplotters. See *Trackplotter*.

Cold Start: Cold Start refers to the procedure that a GPS receiver must perform when it does not have historical information regarding its current location. This procedure typically lasts for several minutes, and may be experienced upon first power up of the receiver, or if the receiver has been moved a great distance.

Course Over Ground (COG): Course Over Ground is the current direction the boat is traveling measured in degrees from North (i.e. 321°, where 000° is North, 090° East, 180° is South, 270° is West). When the Course Over Ground is equal to Bearing, the boat is said to be "On Course" and will arrive at the destination in the most efficient manner. COG is often confused with Heading. See *Heading*.

Cross Track Error (XTE): Cross Track Error is the straight-line distance of the boat from the intended Track. XTE measures how far the boat is off course, and also triggers the Off Course Alarm. See *Track*.

Differential GPS (DGPS): Differential GPS is a system to improve the position accuracy of the Department of Defense GPS through the use of secondary “correction signals” broadcast from ground stations around the coastal United States and on some inland waterways. These correction signals are provided by the USCG and received by an auxiliary Differential Beacon Receiver (DBR) that connects to the GPS receiver. The advent of WAAS has largely negated the need for the added expense of a DBR in the United States.

Distance To Go: Distance To Go is the straight-line distance between Present Position and the Destination Waypoint. DTG and SOG (Speed Over Ground) are used to calculate Time To Go. See *Time to Go* and *Speed Over Ground*.

Estimated Position Error (EPE): Estimated Position Error is a calculation that indicates the potential position inaccuracy the user may experience due to a variety of GPS factors which include satellite position in the sky, signal strength and others factors.

Fix Type: Fix Type indicates whether the GPS receiver is providing 2D fix or 3D fix. A 2D fix requires only three satellites and provides only latitude and longitude. A 3D fix requires four or more satellites, and provides latitude, longitude and altitude.

GPS: GPS is an acronym for Global Positioning System. GPS provides accurate position (latitude, longitude, altitude) information virtually anywhere on the earth through satellite technology and personal receivers on the ground. A series of geosynchronous satellites broadcast a unique signal toward the earth once per second. A GPS receiver, such as that included with many Humminbird® products, receives the signals from these satellites and is able to determine position based on very slight differences in the time each signal is received and the receiver’s knowledge of the location of each of the satellites.

Heading: Heading describes the direction the boat is pointing and is measured in degrees (i.e. 321°, where 000° is North, 090° East, 180° is South, 270° is West). Due to wind and waves, the boat is often traveling in a slightly different direction than it is heading, and therefore Heading is often confused with Course Over Ground. See *Course Over Ground*.

Map Datum: A Map Datum refers to a particular survey of the earth's surface that was referenced when creating a chart (i.e. WGS84). Since the earth is not flat, and not even consistently round, a mathematical model must be used to translate coordinates from the sphere of the earth to the flat surface of a chart. This mathematical model is the Map Datum. Historically, many different Map Datums have been used around the world to create maps; often a reference to the Map Datum can be found in the legend of a paper map. It is important to select the correct Map Datum setting in your fishfinder when comparing GPS position to a paper chart to avoid slight position inaccuracies. Almost all electronic charts use the WGS84 Map Datum and therefore, they do not require setting changes.

MMC: MMC is an acronym for Multi Media Card. An MMC is a postage stamp-sized memory device used to store electronic data such as maps, waypoints, routes and other information. MMC is a very rugged format suitable for the marine environment, but it is not waterproof. The MMC is removable from Humminbird® products, and can be used in a PC that is equipped with an appropriate card reader. MMC is the same format that many digital cameras use. See *SD*.

North, Magnetic: North is the principle reference point of the compass (i.e. North is 000°). Magnetic North relies on the earth's magnetic field to align a metal pointer generally towards True North. However, due to local variations in the earth's magnetic field around the globe, the difference between True North and Magnetic North can be greater than 10°. See *True North*.

North, True: North is the principle reference point of the compass (i.e. North is 000°). True North uses the axis of the rotation of the earth as the reference for North and is constant for all points on the earth. Most GPS units default to True North as the setting. The GPS heading may vary from the boat compass heading because the compass uses Magnetic North. Humminbird® GPS units provide the option of selecting True or Magnetic readouts by using the North Reference menu. See *Magnetic North*.

Present Position: Present Position is the current location (latitude, longitude) determined by GPS. The Present Position is indicated on-screen by a directional boat icon if the boat is moving, or a round symbol if the boat is stationary.

Route: A Route is series of waypoints linked together in a specific sequence to define a navigation path between two points, and saved in the fishfinder's memory. Routes are often used when frequently traveling between two or more locations because it is a faster and more accurate method than repeatedly selecting individual waypoints each time one travels through the same area. Routes consist of a Start Waypoint, an End Waypoint, and a series of waypoints in between. Users can begin navigation at the beginning, the end (to run the route in reverse) or at any waypoint in between. See *Waypoint*.

SD: SD is an acronym for Secure Digital. An SD card is virtually identical in function to an MMC; however, the speed at which information can be accessed is generally faster, the storage capacity is generally larger, and the card has security features which can be used to prevent extracting the data from the card. SD is the same format that many digital cameras use. See *MMC*.

Selective Availability: Selective Availability (SA) is a GPS system "feature" that can be implemented by the U.S. Department of Defense (DoD) to degrade the accuracy of GPS positioning information. With SA active, the GPS is accurate to within 100 meters 95% of the time. With SA inactive, the GPS is accurate to within 45 meters 95% of the time. Currently, SA is inactive and the consumer can enjoy the greater precision GPS provides; however, the DoD reserves the right to activate SA at any time.

Speed Over Ground (SOG): Speed Over Ground is the measurement of the boat's progress across a given distance, and is the speed measurement provided by GPS. An alternate, Speed Through Water, is provided by a speed paddlewheel, and is the measurement of the flow past the boat, which may vary depending on current speed and direction. Speed Over Ground is optimal for navigation because accurate destination times can be derived from this measurement. Humminbird® products allow for input and display of both speed measurements.

Time To Go (TTG): Time To Go is the estimated time required to reach the destination waypoint. TTG is calculated using the SOG and DTG. See *SOG* and *DTG*.

Track: A Track is a series of saved points that define the past path of the boat. These Track Points are saved at regular time intervals. Tracks are a useful and quick method to see where you've been, and an easy guide to follow to get you back to the starting point. Generally, all GPS units have a limited number of Track Points

that can be saved before the unit runs out of memory and begins erasing the first track points saved. Because of this, the user can adjust the Track Point Interval menu to increase the amount of time between when points are saved, and thus extend the distance covered by a track. Tracks can also be permanently saved to memory, and re-displayed at the user's option.

Track Line (TRK): The Track Line is the desired line of travel between two waypoints, and represents the most efficient path between the two points because it is a straight line. The TRK is measured in degrees (i.e. 321°, where 000° is North, 090° East, 180° is South, 270° is West). See *Cross Track Error* and *Course Over Ground*.

Trackplotter: Trackplotter describes a navigation device that shows Present Position, along with Track, Waypoint, and Routes, but NO MAP in the background. See *Chartplotter*.

Trolling Grid: Trolling Grid is a Humminbird® feature that displays a precise reference grid around a waypoint. This grid is used as a guide pattern for trolling around a specific area to assure a more efficient and complete coverage of that area. Trolling Grid resolution be changed by zooming in or out on the chart. The Trolling Grid can also be rotated on the display to orient it for optimal boat course for wave and wind conditions.

UTC: UTC is an acronym for Universal Time Constant. UTC is the "standard time" used in navigation, and is the local time in Greenwich England. (UTC is equivalent to Greenwich Mean Time (GMT)). To display the correct Local Time in a Humminbird® GPS unit, the user must use the Local Time Zone menu and select the time zone (i.e. EST, CST).

WAAS: WAAS is an acronym for Wide Area Augmentation System. WAAS is complementary technology to GPS that provides enhanced accuracy through correction signals broadcast from Federal Aviation Administration WAAS satellites stationed over the USA. These secondary signals are automatically received by the standard Humminbird® GPS Receiver. With WAAS signal, GPS accuracy is improved to within 3 meters 95% of the time. Outside the United States, regional governmental coalitions have created similar systems such as EGNOS (Europe) and MSAS (Japan).

Waypoint: A Waypoint is the saved location (latitude, longitude) of a point of interest that is stored in a GPS receiver's memory. This can include a marker buoy, dock, fishing hole or anywhere else the user may want to return to. Humminbird® products offer the ability to name and assign a symbol to the saved location. Depth, Date and Time of Day when the waypoint was created is also saved.

Waypoint Target: Waypoint Target is a Humminbird® feature that displays a precise "bull's eye" around a selected waypoint. This bull's eye is used to easily monitor boat position relative to a waypoint, and is useful for fishing over submerged structure. With Waypoint Targets, a quick look at the screen lets you know how far off the waypoint the boat has drifted.

Contact Humminbird®

Contact the Humminbird® Customer Resource Center
in any of the following ways:

By Telephone:

(Monday - Friday 8:00 a.m. to 4:30 p.m. Central Standard Time):

1-800-633-1468

By e-mail:

(typically we respond to your e-mail within three business days):

custserv@johnsonoutdoors.com

For direct shipping, our address is:

Humminbird

Service Department

678 Humminbird Lane

Eufaula, AL 36027 USA



HUMMINBIRD®