

Installation Instructions

**344 &
344S**
Series A

BLOWER UNIT HEATERS

bryant

39344D1
11/15/71

Before proceeding to install Models 344 and 344S Blower Unit Heaters, refer to Bryant form No. 39003D1 "Procedures for Gas Appliances" (packaged with the equipment) for information concerning combustion, venting, piping, and other standard installation practices. The current edition of the American National Standard "Installation of Gas Appliances and Gas Piping", Z21.30, takes precedence over all other reference publications pertinent to this installation instruction. Both models are shipped factory-assembled. Installation comprises the following:

- * I. Inspection
- * II. Location and Suspension
- * III. Gas Piping
- IV. Wiring
- * V. Venting
- VI. Start-up and Adjustment
- VII. Service and Maintenance

*To perform these sections (or installation steps), refer to the appropriate sections of Bryant form No. 39003D1 (packaged with this equipment).

SPECIAL AIRPLANE HANGAR AND GARAGE APPLICATION PRECAUTIONS

NOTE: Refer to NFPA No. 409-1969, "Standard on Aircraft Hangars," and NFPA No. 88-1968, "Standard for Garages."

1. A clearance of 10 feet to bottom of Heater from top of a wing or fuselage of aircraft likely to be housed in hangar must be maintained.
2. A minimum clearance of 8 feet from floor to bottom of Heater in other sections of aircraft hangar, such as offices and shops which communicate with areas used for servicing or storage, must be maintained.

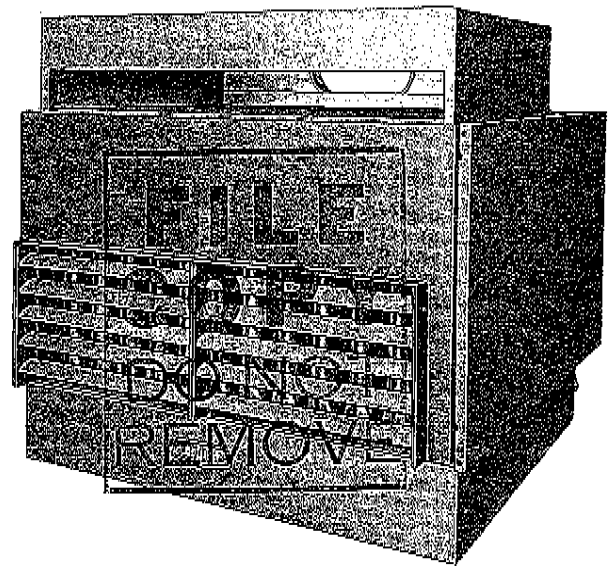

B71438

Figure 1

3. Heater must be so located that it is protected from damage by aircraft or other objects such as cranes or movable scaffoldings. In addition, it must be located to be accessible for servicing and adjustment.
4. A clearance of 6 inches from combustible material must be maintained from top and flue connector. Eighteen inches on each side and 24 inches from any obstruction at bottom of Heater must be maintained.

TABLE I—CONTROL OPTIONS¹

COMPONENT	PROPANE GAS D2	NATURAL D4	NATURAL D5
Bryant Auto-Pilot		x	x
Bryant Gas Valve*	x	x	x
Gas Pressure Regulator*	—	x	x
Transformer	x	x	x
100% Shutoff	x	—	x
Thermocouple Pilot	x	—	x
Pilot Relay or Pilotstat	x	—	x

¹All three options available on 344 & 344S are available with D2 propane and D5 natural gas only.

*A-643 Bryant Gas Valve with integral Gas Pressure Regulator is used on D4 and D5 for size 150; A-641 Gas Valve without regulator is used on D2 for all sizes. A-641 with separate Gas Pressure Regulator is used on D4 and D5 for sizes 200 thru 400.

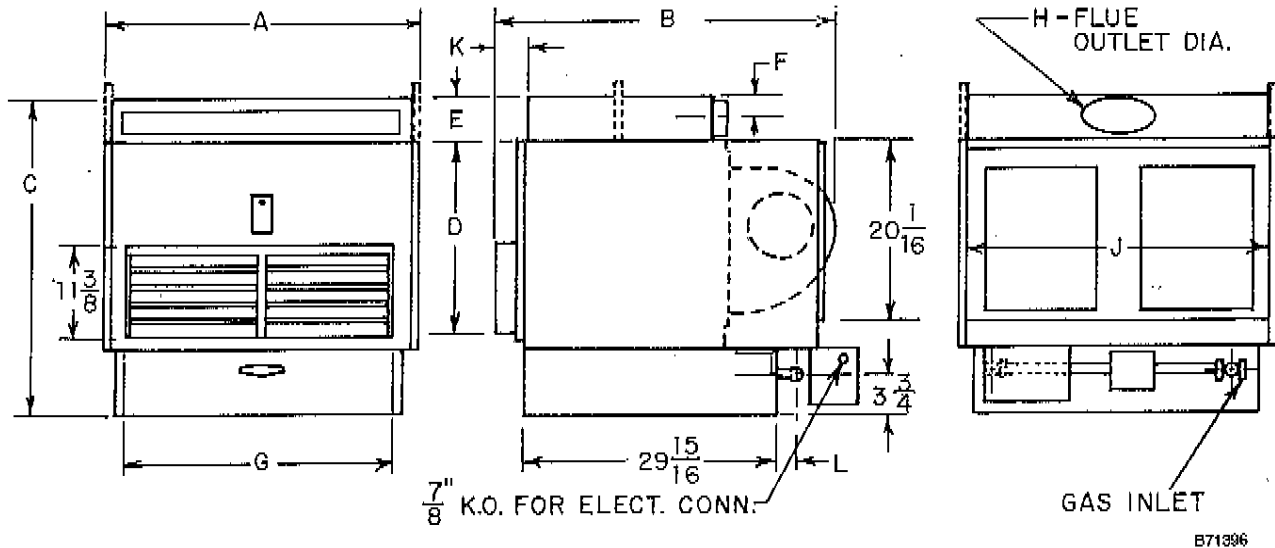

Figure 2 - Dimensional Drawing

TABLE II—DIMENSIONS IN INCHES—MODEL 344

Size	A	B	C	D	E	F	G	H	J	K	L	Gas Inlet	Approx. Shipping Weight
150	18-1/2	44-3/16	30-1/16	21-3/4	5-11/16	2-7/8	14-3/8	7	17	3-3/16	3-7/16	1/2	215
200	24-1/2	44-3/16	34-9/16	21-3/4	5-11/16	2-7/8	17-3/8	8	23	3-3/16	3-7/16	1/2	280
250	33-1/2	44-3/16	34-9/16	21-3/4	5-11/16	2-7/8	28-3/4	8	32	3-3/16	3-9/16	3/4	380
300	39-1/2	44-3/16	36-9/16	21-3/4	7-11/16	3-7/8	34-3/4	9	38	3-3/16	3-9/16	3/4	465
400	51-1/2	44-3/16	38-1/16	21-3/4	9-3/16	4-5/8	46-3/4	10	50	3-3/16	3-5/16	3/4	625

Specific Location and Suspension Precautions

For general location and suspension information, refer to Section II of Bryant form No. 39003D1. In addition, the following precautions should be observed when selecting a mounting site.

1. Direct heated airstream toward area having greatest heat loss.
2. For multiple installations, locate Heaters so that each will warm a specific area. Arrange so that overall air pattern results in continuous circular flow of warm air throughout space.
3. Do not locate Heater in areas where combustion air is limited, or is not replaced.
4. If located in spaces equipped with exhaust fans, provide sufficient makeup air to allow proper venting of Heater.
5. Two 1/2-inch pipe tappings are provided in top casing for use in suspending Heater. Use pipe unions to join Unit Heater to ceiling hangar. Two additional 1/2-inch pipe tapped brackets are supplied for balancing Heater.

IV. WIRING

Make all electrical connections in accordance with the National Electric Code and any local codes that may apply.

If aluminum conductors are to be used, the wire size selected must have a current capacity not less than that of the copper wire specified and must not create a voltage drop between the service panel and the unit in excess of 2% of the unit rated voltage. As a minimum, aluminum wire must be treated to prevent oxidation.

With electric power turned off, recheck all electrical connections (both factory and field) for tightness. Be sure to check power supply connections, especially if aluminum conductors are used.

The Blower Unit Heater is completely wired at the factory and is ready for connections to power source. See wiring diagram.

The heat anticipator on the thermostat should be set at 0.8 amps.

TABLE III—THROW CHART

Model	Velocity High Speed ft/min	High Speed		Low Speed		EFFECTIVE THROW* AND MOUNTING HEIGHT												
		CFM	Temp Rise °F	CFM	Temp Rise °F	Distance from Floor to Top of Heater In Ft.												
						8	10	12	14	16	18	20	22	24	26	28	30	32
150-344	2100	1650	65	1340	80	100	98	95	93	90	88	85	83	80	78	75	73	70
200-344	2100	2100	67	1700	85	100	98	95	93	90	88	85	83	80	78	75	73	70
250-344	2100	3100	60	2600	70	120	118	115	113	110	108	105	103	100	98	95	93	90
300-344	2100	3600	60	3000	70	130	128	125	123	120	118	115	113	110	108	105	103	100
400-344	2100	4200	67	3400	85	130	128	125	123	120	118	115	113	110	108	105	103	100

*Effective throw as shown is the horizontal distance in feet that the heated airstream travels from the outlet of the unit heater with louvers positioned for maximum throw with air reaching the floor. Spread or width of the air pattern is approximately 20% of the maximum throw. For additional spread, use vertical louvers. Above data are test results.

VI. START-UP AND ADJUSTMENT

1. Start unit using procedure outlined on lighting instruction plate attached to Heater.
2. Adjust pilot flame. Use adjusting screw under screw cap on pilot valve for this purpose.

For D4 controls, flame should be long enough for good impingement on metal element of Bryant automatic pilot. For D5 and D2 controls, flame should surround thermocouple element of pilot and extend downward to include 3/8 to 1/2 inch of thermocouple. Flame should never come in contact with any other part of thermocouple or its lead wire.

To adjust pilot flame on units equipped with a Model A-643 valve, adjustment screw is located in pilot outlet portion of valve body. Remove capscrew, make necessary adjustment, and replace capscrew.

3. Check input. Input should be checked at meter to make sure that it corresponds with input shown on rating plate attached to unit. See Bryant form No. 39003D1 for method.
4. Final Checkout. Move thermostat setting above and below room temperature several times, pausing between each "on" and "off" cycle to make sure that main burners ignite properly.

Attach a low-voltage test light to electrical leads of gas valve. With thermostat set above room temperature, close manual pilot valve. If light goes out when pilot cools, pilot is functioning properly. The test light should go out within 45 seconds after pilot gas supply is turned off.

Check the operation of temperature limit control. This can be done by allowing burners to operate while fan is not running to see that limit switch opens.

Check all connections in the gas piping for leaks. Use a soap-and-water solution.

WARNING: Never use a flame to check for leaks.

VII. SERVICE AND MAINTENANCE

1. Pilot Orifice - is located in bottom fitting of pilot and is readily accessible for inspection and cleaning.
2. Main Burner Orifices - The orifice is readily unscrewed from manifold after burner is removed.
3. Removing Main Burners - Lift rear of burner and push it away from manifold enough to disengage orifice spud from mixer shield. Then pull down and out of Heater. End of burner away from manifold seats in a slotted burner support. It is necessary to lift burner out of this slot before attempting to push burner back. See Figure 8.

NOTE: Disconnect the pilot tubing and wires to remove the burner that holds the pilot. However, it is not necessary to remove the pilot itself from the burner.

4. Cleaning - Heat exchanger tubes should be inspected at regular intervals and cleaned when necessary.
 - a. Shut off gas and electricity. Heater should be cool.
 - b. Disconnect pilot tube and wires.
 - c. Remove main burners and pilot.
 - d. Use stiff brush to scrub heat exchanger tubes. Remove all loose scale and any soot that may have collected.
 - e. Replace burners and pilot. Reconnect pilot tube and wires.
 - f. Unit is now ready for relighting.

5. Oiling-direct-drive sleeve-bearing blower motors are prelubricated and normally will not need further oiling for approximately 5 years. Lubricating then should be performed by an experienced serviceman as blower assembly will have to be disassembled.

Each sleeve bearing on above motors should be oiled with 25 drops of SAE 20 nondetergent motor oil annually after 5 years. Avoid over-oiling.

WIRING DIAGRAMS FOR SIZES 150 & 200

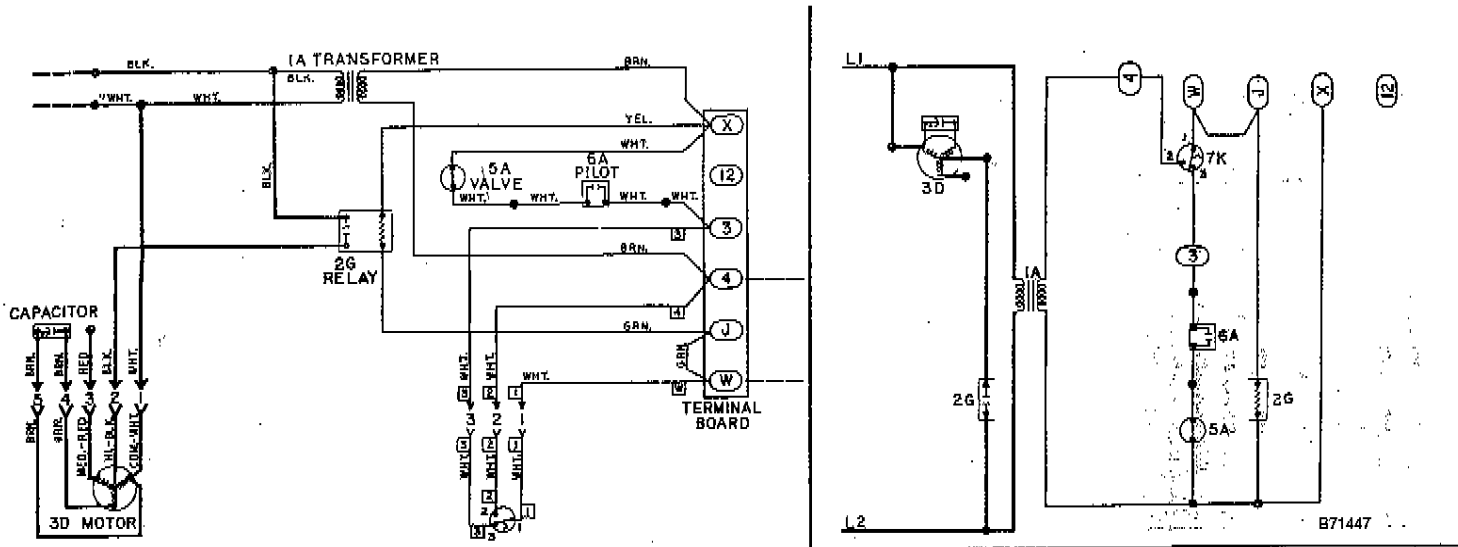

IF ANY OF THE ORIGINAL WIRE AS SUPPLIED WITH THE APPLIANCE MUST BE REPLACED, IT MUST BE REPLACED WITH TYPE SFF-2 150C FOR 24-VOLT CIRCUITS AND APPLIANCE WIRING MATERIAL 105C FOR LINE VOLTAGE CIRCUITS.

THIS UNIT IS APPROVED FOR 0.25 WC STATIC 55° TO 85° RISE, SEE INSTALLATION INSTRUCTIONS OR APPLICATION MANUAL BEFORE CHANGING SPEED TAPS OR ADDING DUCTWORK.

— FACTORY LINE VOLTAGE
 — FACTORY LOW VOLTAGE
 - - - FIELD LINE VOLTAGE
 - - - FIELD LOW VOLTAGE

1A-TRANSFORMER
 2G-BLOWER RELAY
 3D-BLOWER MOTOR
 5A-HEAT MOTOR VALVE
 6A-PILOT SWITCH (OMIT ON PROPANE)
 7K-TEMPERATURE LIMIT CONTROL

Figure 3 - With 732 Pilot Installed Non 100% Shutoff, Nat. Gas (D4)

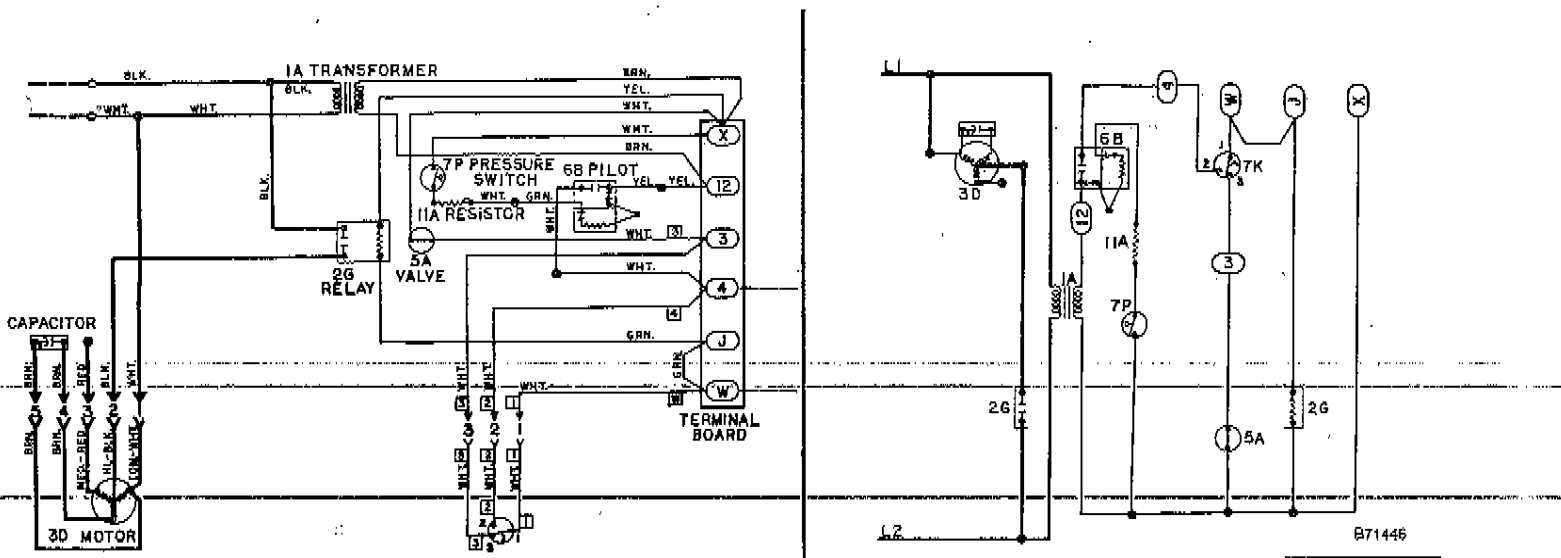

IF ANY OF THE ORIGINAL WIRE AS SUPPLIED WITH THE APPLIANCE MUST BE REPLACED, IT MUST BE REPLACED WITH TYPE SFF-2 150C FOR 24-VOLT CIRCUITS AND APPLIANCE WIRING MATERIAL 105C FOR LINE VOLTAGE CIRCUITS.

THIS UNIT IS APPROVED FOR 0.25 WC STATIC 55° TO 85° RISE, SEE INSTALLATION INSTRUCTIONS OR APPLICATION MANUAL BEFORE CHANGING SPEED TAPS OR ADDING DUCTWORK.

— FACTORY LINE VOLTAGE
 — FACTORY LOW VOLTAGE
 - - - FIELD LINE VOLTAGE
 - - - FIELD LOW VOLTAGE

1A-TRANSFORMER
 2G-BLOWER RELAY
 3D-BLOWER MOTOR
 5A-HEAT MOTOR VALVE
 6B-733 PILOT (REIGNITION)
 7K-TEMPERATURE LIMIT CONTROL
 7P-PRESSURE SWITCH SPST
 11A-RESISTOR

Figure 4 - With 733 Pilot Installed Automatic Electric Reignition (D1)

WIRING DIAGRAMS FOR SIZES 250, 300, & 400

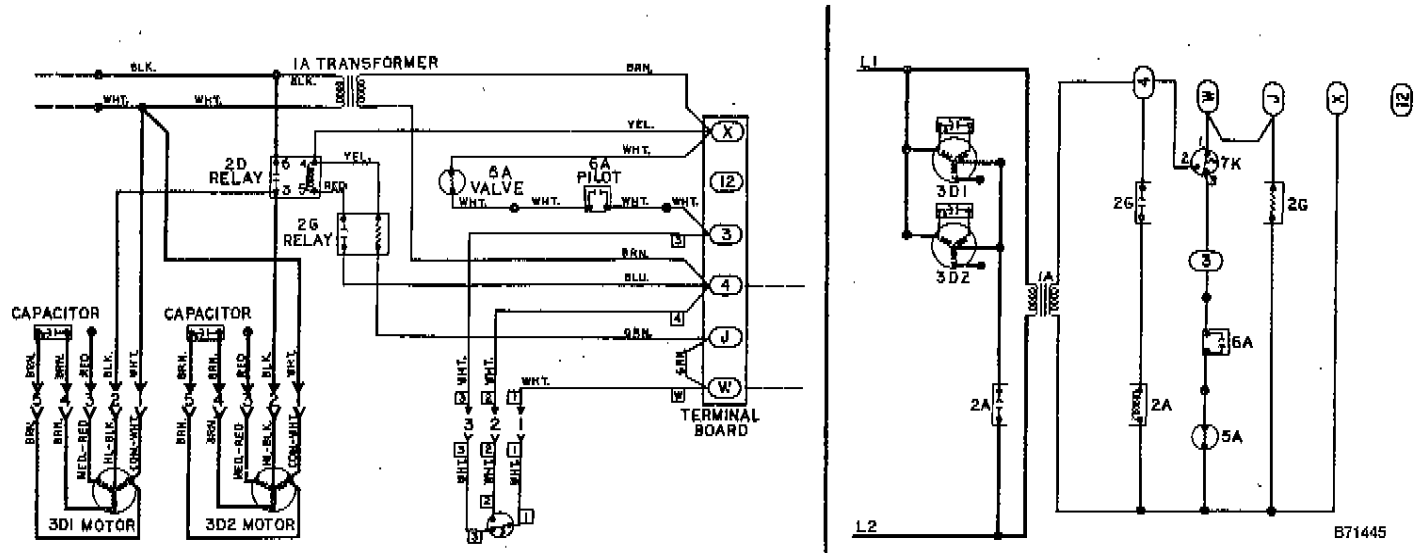

IF ANY OF THE ORIGINAL WIRE AS SUPPLIED WITH THE APPLIANCE MUST BE REPLACED, IT MUST BE REPLACED WITH TYPE SFF-2 150C FOR 24-VOLT CIRCUITS AND APPLIANCE WIRING MATERIAL 105C FOR LINE VOLTAGE CIRCUITS.

THIS UNIT IS APPROVED FOR 0.25 WC STATIC 55° TO 85° RISE, SEE INSTALLATION INSTRUCTIONS OR APPLICATION MANUAL BEFORE CHANGING SPEED TAPS OR ADDING DUCTWORK.

——— FACTORY LINE VOLTAGE
 - - - - - FACTORY LOW VOLTAGE
 - - - - - FIELD LINE VOLTAGE
 - - - - - FIELD LOW VOLTAGE

1A-TRANSFORMER
 2A-BLOWER RELAY
 2G-HEAT-MOTOR-OPERATED RELAY
 3D1&2-BLOWER MOTOR
 5A-HEAT MOTOR VALVE
 6A-PILOT SWITCH (OMIT ON PROPANE)
 7K-TEMPERATURE LIMIT CONTROL

Figure 5 - With 732 Pilot Installed Non 100% Shutoff, Nat. Gas (D4)

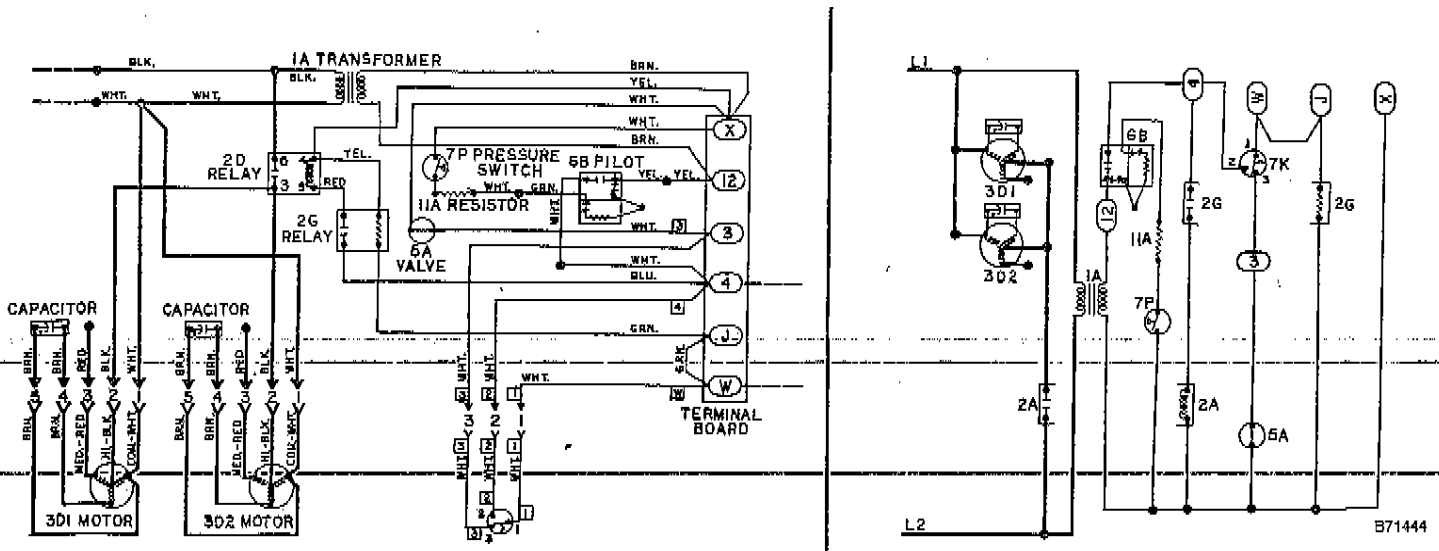

IF ANY OF THE ORIGINAL WIRE AS SUPPLIED WITH THE APPLIANCE MUST BE REPLACED, IT MUST BE REPLACED WITH TYPE SFF-2 150C FOR 24-VOLT CIRCUITS AND APPLIANCE WIRING MATERIAL 105C FOR LINE VOLTAGE CIRCUITS.

THIS UNIT IS APPROVED FOR 0.25 WC STATIC 55° TO 85° RISE, SEE INSTALLATION INSTRUCTIONS OR APPLICATION MANUAL BEFORE CHANGING SPEED TAPS OR ADDING DUCTWORK.

——— FACTORY LINE VOLTAGE
 - - - - - FACTORY LOW VOLTAGE
 - - - - - FIELD LINE VOLTAGE
 - - - - - FIELD LOW VOLTAGE

1A-TRANSFORMER
 2A-BLOWER RELAY
 2G-HEAT-MOTOR-OPERATED RELAY
 3D1&2-BLOWER MOTOR
 5A-HEAT MOTOR VALVE
 6B-733 PILOT (REIGNITION)
 7K-TEMPERATURE LIMIT CONTROL
 7P-PRESSURE SWITCH SPST
 11A-RESISTOR

Figure 6 - With 733 Pilot Installed Automatic Electric Reignition (D1)

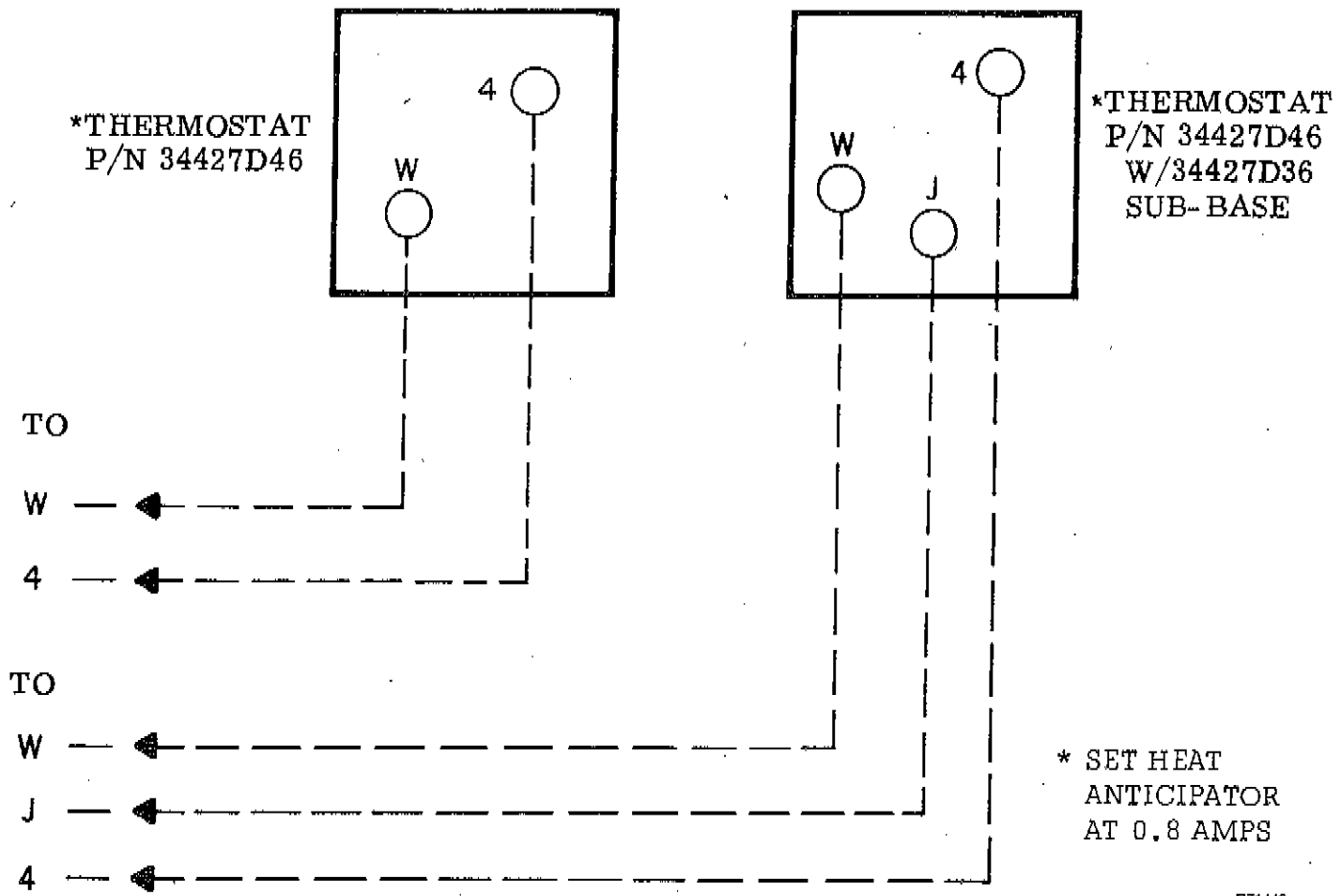

B71448

SEPARATE WIRES MARKED W & J AT THERMOSTAT CONNECTIONS WHEN SUB-BASE P/N34427D36 IS USED FOR SUMMER FAN

Figure 7 - Thermostat Field Wiring

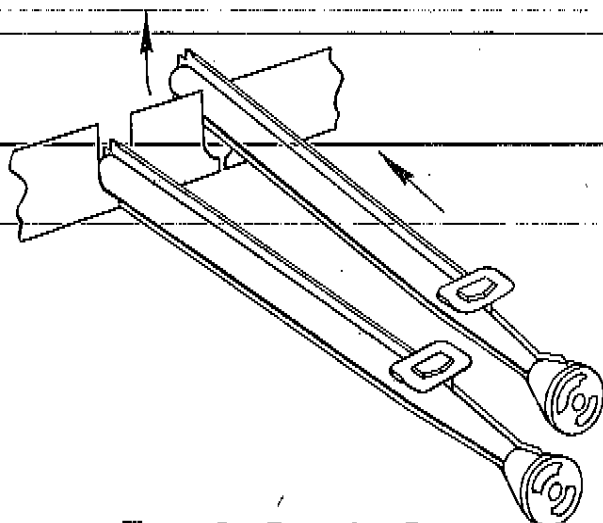

A66032

Figure 8 - Removing Burner