

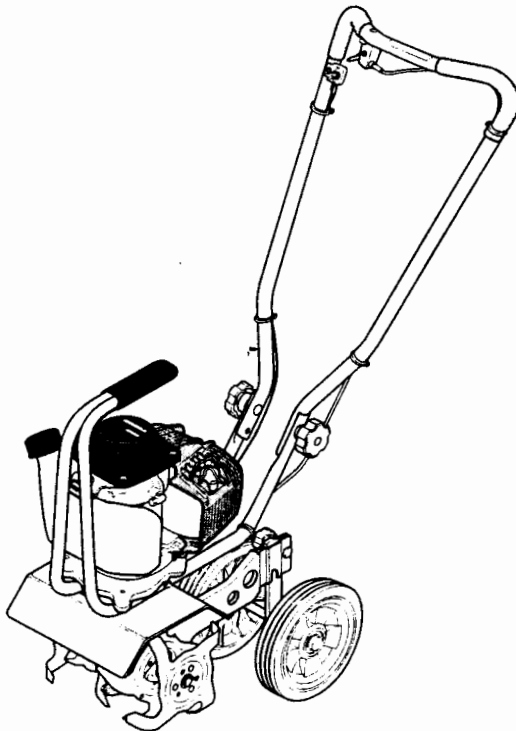

Operator's Manual

Tiller/Edger Model
148H



IMPORTANT: READ SAFETY RULES AND INSTRUCTIONS CAREFULLY

Warning: This unit is equipped with an internal combustion engine and should not be used on or near any unimproved forest-covered, brush-covered or grass-covered land unless the engine's exhaust system is equipped with a spark arrester meeting applicable local or state laws (if any). If a spark arrester is used, it should be maintained in effective working order by the operator. In the State of California the above is required by law (Section 4442 of the California Public Resources Code). Other states may have similar laws. Federal laws apply on federal lands. A spark arrester for the muffler is available by contacting the service department at Troy-Bilt LLC, P.O. Box 361131 Cleveland, Ohio 44136-0019.

TROY-BILT LLC, P.O. BOX 361131, CLEVELAND, OH 44136-0019

PRINTED IN USA

FROM NO. 770-10600
(12/2001)

TABLE OF CONTENTS

Content	Page
Calling Customer Support	2
Safety	3
Assembly	5
Features and Controls	6
Operation	7
Maintenance	10
Troubleshooting	12
Storage	12
Parts List	13
Warranty Information	Back Cover

FINDING MODEL NUMBER

This Operator's Manual is an important part of your new Tiller/Edger. It will help you assemble, prepare and maintain the unit for best performance. Please read and understand what it says.

Before you start assembling your new equipment, please locate the model plate on the equipment and copy the information from it in the space provided below. This information is very important if you need help from our Customer Support Department or an authorized dealer.

- You can locate the model number by looking at the rear surface of the tine shield. A sample model plate is explained below. For future reference, please copy the model number and the serial number of the equipment in the space below

 <p>TROY-BILT www.troybilt.com TROY-BILT LLC P. O. BOX 361131 CLEVELAND, OH 44136 330-558-7220 866-840-6483</p>	Copy Model Number Here _____
	Copy Serial Number Here _____

ENGINE INFORMATION

The engine manufacturer is responsible for all engine-related issues with regards to performance, power-rating, specifications, warranty and service. Please refer to the engine manufacturer's Owner's/Operator's Manual packed separately with your unit for more information.

CALLING CUSTOMER SUPPORT

If you have difficulty assembling this product or have any questions regarding the controls, operation or maintenance of this unit, please call the Customer Support Department.



Call 1- (330) 558-7220 or 1- (866) 840-6483 to reach a Customer Support representative. Please have your unit's model number and serial number ready when you call. See previous section to locate this information. You will be asked to enter the serial number in order to process your call ..

For more details about your unit, visit our website at www.troybilt.com

Safety

Safety Alert Symbol



This is a safety alert symbol. It is used in this manual and on the unit to alert you to potential hazards. When you see this symbol, read and obey the message that follows it. Failure to obey safety messages could result in personal injury or property damage.

TRAINING

- Read this Owner's Manual and the separate Engine Owner's Manual very carefully before operating this equipment. Be completely familiar with the controls and the proper use of the equipment. Know how to stop the unit and disengage the controls quickly. A replacement Manual is available by contacting your authorized dealer or the Factory.
- Never allow children or untrained adults to use this equipment. Let adults operate the unit only if instructed properly.
- Keep the area of operation clear of all persons, particularly small children and pets. Keep bystanders at least 25 feet from the area of operation.
- Keep in mind that the operator or user is responsible for accidents or hazards occurring to other people, their property and themselves.
- Familiarize yourself with all of the safety and operating decals on this equipment and on any of its attachments or accessories.
- Do not run engine in an enclosed area. Engine exhaust contains carbon monoxide gas, a deadly poison that is odorless, colorless, and tasteless. Do not operate this equipment near buildings, windows, or air conditioning equipment.
- Do not allow hands or any other part of the body or clothing near the rotating tines or near any other moving part. The tines begin to rotate forward once the engine is started and the Throttle/Tines Control Lever is squeezed. The tines continue to rotate until the operator releases the Throttle/Tines Control Lever.
- Before inspecting or servicing any part of the equipment, shut off engine, make sure all moving parts have come to a complete stop, then disconnect spark plug wire from spark plug and move wire away from the plug.

- Do not operate this equipment if you are under the influence of alcohol, medication, or when you are tired or ill.

PREPARATION

- Thoroughly inspect the area where the equipment is to be used and remove all foreign objects.
- Make sure that the Throttle/Tines Control Lever is disengaged and is in the neutral position before you begin to start the engine.
- Do not operate the machine without wearing adequate outer garments. Avoid loose garments or jewelry that could get caught in moving parts of the machine or its engine.
- Do not operate the equipment when barefoot or when wearing sandals, sneakers, or similar lightweight footwear. Wear protective footwear that will protect your feet and improve footing on all surfaces.
- Wear approved safety glasses when operating this equipment. The operation of any powered machine can result in foreign objects being thrown by high-speed rotating parts.
- Do not till near underground electric cables, telephone lines, pipes, or hoses. If in doubt, contact your utility or telephone company to locate underground services.
- Handle fuel with care. It is highly flammable and has explosive vapors. Take these precautions:
 - a. Use an approved fuel container.
 - b. Add fuel before starting the engine. Never remove the cap of the fuel tank or add fuel while the engine is running or when the engine is hot. Operators shall not smoke.
 - c. Keep matches, cigarettes, cigars, pipes, open flames, and sparks away from the fuel tank and fuel container.

- d. Fill fuel tank outdoors and with extreme caution. Never fill fuel tank when indoors. Use a funnel or spout to prevent spillage.
 - e. Replace all fuel tank and fuel container caps securely.
 - f. If fuel is spilled, do not attempt to start the engine, but move the machine away from the area of spillage and avoid creating any source of ignition until fuel vapors have dissipated.
- Never make adjustments to your equipment when the engine is running or spark plug wire is connected (unless specifically recommended in Owner's Manual).

OPERATION

Operator's Position

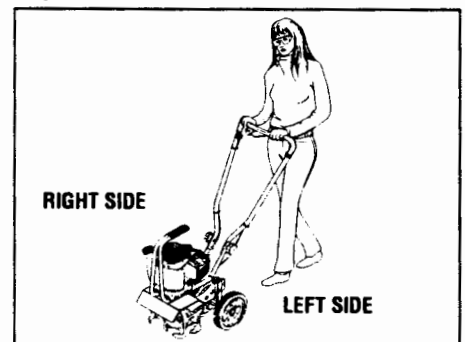

LEFT and RIGHT sides of the tiller are from the operator's position behind the handlebars (unless noted otherwise).

- The correct operator's position is when you are standing behind and gripping the handlebar, facing forward toward the engine. Do not leave this position while using the engine Throttle/Tines lever.
- Do not put hands or feet near or under rotating parts.

This machine meets voluntary safety standard B71.8 – 1996, which is sponsored by the Outdoor Power Equipment Institute, Inc., and is published by the American National Standards Institute.



WARNING

The engine exhaust from this product contains chemicals known to the State of California to cause cancer, birth defects or other reproductive harm.

Section 1: Safety

- Exercise extreme caution when on or crossing gravel drives, walks or roads. Stay alert for hidden hazards or traffic. Do not carry passengers.
- After striking a foreign object, stop the engine, let all moving parts come to a complete stop, disconnect the spark plug wire and prevent it from touching the spark plug, then carefully inspect the machine for damage. Repair the damage before restarting and operating the machine.
- Exercise caution to avoid slipping or falling.
- If the machine should start to vibrate abnormally, stop the engine. Disconnect the spark plug wire and prevent it from touching the plug. Check immediately for the cause. Vibration is generally a warning of trouble. Fix the problem before using the equipment again.
- Stop the engine, disconnect the spark plug wire and prevent it from touching the spark plug whenever you leave the equipment, before unclogging the tines, or when making any repairs, adjustments or inspections.
- Take all possible precautions when leaving the machine unattended. Always stop the engine. Disconnect the spark plug wire and prevent it from touching the plug.
- Before cleaning, repairing, or inspecting, stop the engine and make certain all moving parts have stopped. Disconnect the spark plug wire and prevent it from touching the spark plug to avoid accidental starting.
- Never operate equipment without proper guards, plates, or other protective safety devices in place.
- Do not run the engine in an enclosed area. The exhaust fumes from the engine contain extremely dangerous carbon monoxide gas. This gas is colorless, odorless, tasteless and deadly poisonous.
- Keep children and pets away.
- Be aware that the equipment may unexpectedly bounce upward or jump forward if the tines should strike extremely hard packed soil, frozen ground, or buried obstacles such as large stones, roots or stumps. If you are in doubt about the tilling conditions, always use the following operating precautions to assist you in maintaining control of the equipment:
 - a. Stand behind the equipment, using both hands on the handlebars. Relax your arms, but use a secure hand grip.
 - b. Start tilling at shallow depths, working gradually deeper with each pass.
 - c. Clear the tilling area of all large stones, roots, and other debris.
 - d. In an emergency, stop the tines by releasing the engine Throttle/Tines lever on the handlebar. To stop the engine, move the engine On/Off switch to OFF.

- Do not touch engine parts which may be hot from operation. Allow parts to cool before inspecting, cleaning or repairing.
- Remember: you can stop the tines by releasing the engine Throttle/Tines lever. Move the engine On/Off switch to OFF to shut the engine off.
- Never transport this machine when the engine is running.
- Terminals and non-insulated electrical parts shall be protected against shorting during normal servicing, refueling or lubrication.
- Use extreme caution when reversing or pulling the machine toward you.
- Start the engine carefully according to instructions and with feet well away from the tines.

MAINTENANCE/STORAGE

- Keep the tiller, attachments and accessories in safe working condition.
- Check all nuts, bolts, and screws at frequent intervals for proper tightness to be sure equipment is in safe working condition.
- Never store equipment with fuel in fuel tank inside a building where fumes may reach an open flame or spark (hot water and space heaters, furnaces, clothes dryers, stoves, electric motors, etc.).
- Allow the engine to cool before storing the equipment.
- Keep the engine free of grass, leaves, or grease to reduce the chance of a fire hazard.
- Store gasoline in a cool, well-ventilated area, safely away from any spark- or flame-producing equipment. Store gasoline in an approved container, safely away from the reach of children.
- Never perform maintenance when engine is running or spark plug wire is connected unless instructed to do so.
- If fuel tank must be drained, do so outdoors.
- Follow manufacturer's recommendations for safe loading, unloading, transport and storage of machine.

Assembly

⚠ WARNING

To prevent personal injury or property damage, do not start the engine until all assembly steps are complete and you have read and understand the safety and operating instructions in this manual.

INTRODUCTION

Carefully read these instructions in their entirety before you attempt to assemble or operate your new equipment.

The Border Edger Attachment (D, Figure 1) does not need to be installed until you are ready to do edging projects (refer to instructions in Section 4).

UNPACKING INSTRUCTIONS

1. Inspect your machine immediately. If you find or suspect damage to the carton or contents, contact your local authorized dealer or the Factory for assistance.
2. Remove any packing material. Check for loose parts before discarding the packing material or carton. Loose parts include the following:

- (1) Wheel (for edging)
- (1) Edger Tine
- (2) *Long Bushings
- (1) *Short Bushing

*Packed in a separate plastic bag.

3. Perform the assembly on a clean, level surface. Be careful not to severely bend any of the control cables on the unit.

ASSEMBLY STEPS

STEP 1: Unfold and Adjust Handlebars

IMPORTANT: Be careful not to pinch any control cables. Push the cables out and away before swiveling the handlebars.

1. Loosen the two handlebar knobs (A, Figure 1) and unfold the handlebars into the operating position. Do not use force — if there is binding, continue to loosen the knobs.
2. There are two height setting holes in the upper handlebar. The unit is shipped with the handlebar knobs in the lowest height setting holes. If this height is correct for you, simply tighten the two handlebar knobs. If desired, reposition the handlebar knobs, mounting screws and washers in the other set of holes.
3. Check the six (6) plastic ties (C, Figure 1). Ties must be positioned as shown.

NOTE: There is only one handlebar storage position — folded over and down as originally shipped.

STEP 2: Inspect and Tighten Hardware

Check all nuts, bolts and screws on your unit and tighten as needed.

Tools Needed to Check for Loose Hardware:

- Adjustable wrench
- Slotted-head screwdriver
- Phillips-head screwdriver
- 7/16" socket and extension
(to check hardware at ends of handlebar)

STEP 3: Add Motor Oil to Engine

IMPORTANT: The engine is shipped without oil in the crankcase. Do not start the engine without first adding motor oil. Severe engine damage will result if the engine is run without motor oil.

1. Refer to the separate Engine Owner's Manual for motor oil specifications and capacities.
2. Add oil as described in the Engine Owner's Manual (the engine is a vertical type, GX 31 model).

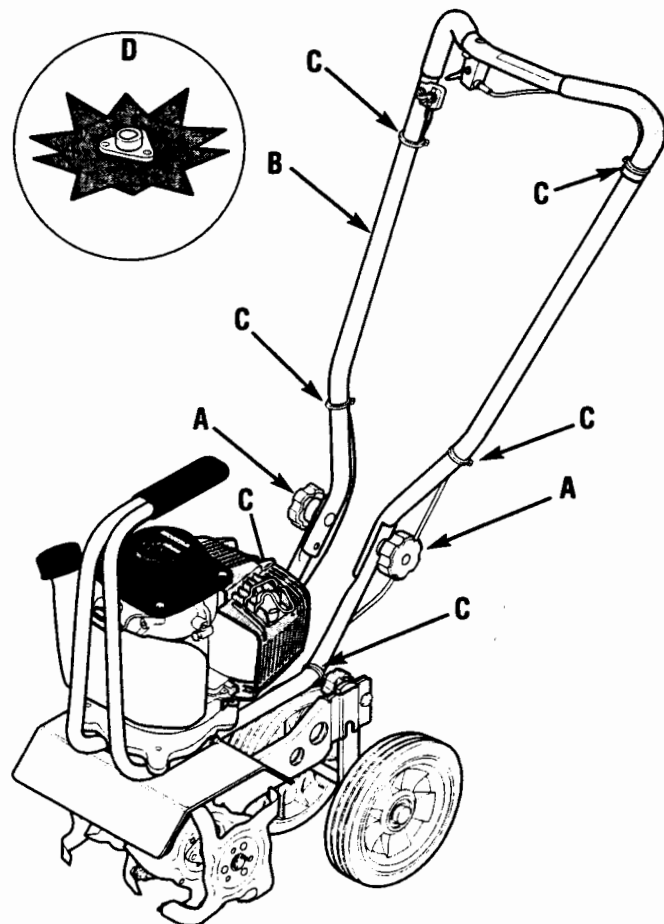

Figure 1

Features and Controls

KNOW YOUR EQUIPMENT

READ THIS OWNER'S MANUAL AND ALL SAFETY RULES BEFORE OPERATING YOUR EQUIPMENT. Know the location and function of all features and controls on the equipment. Save this manual for future reference.

⚠ WARNING

Before operating your machine, carefully read and understand all safety, control, and operating instructions in this Manual, the separate Engine Owner's Manual and on the decals on the machine.

Failure to follow these instructions can result in serious personal injury.

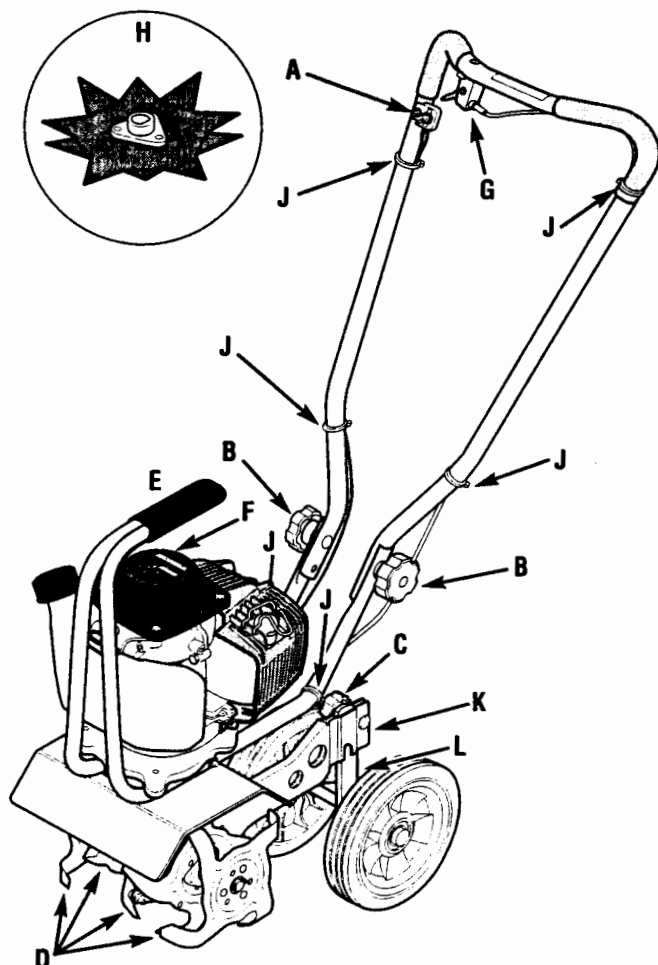

Figure 2: Features and controls.

Handlebar Height Adjustment Knob (B, Figure 2)

Two height settings, plus a storage position are available. Refer to *Assembly Steps, STEP 1* in Section 2 for adjustment instructions.

Tilling Depth Adjustment Knob (C, Figure 2)

Loosening the knob enables you to move the wheel bracket (K) up or down on the height adjustment bar (L). This controls the tilling depth.

IMPORTANT: Do not move the wheel bracket any higher than the top of the adjustment bar.

Adjustable Tine Patterns (D, Figure 2)

The four tine sections are arranged from the factory for maximum performance under a wide variety of conditions. If needed, the tines can be arranged for narrower tilling or close cultivating. The tines can also be arranged to till very stony soil. See *Adjusting Tine Positions* in Section 4 for details.

Carrying Handle (E, Figure 2)

When the handlebar is folded in the storage position the unit can be carried by the carrying handle. The carrying handle also serves as a tie-down anchor point.

Edger Attachment (H, Figure 2)

Use this separate attachment to create borders or edges along walks, driveways, flower beds, etc. See Section 4 for details on installing and using this attachment.

Engine Controls

Fuel Primer Bulb (Section 4, Figure 4)

Use the Fuel Primer Bulb to help start the engine under certain conditions. See *Stopping and Starting the Engine* in Section 4 and the Engine Owner's Manual for details.

Engine Choke (Section 4, Figure 5)

Use the Engine Choke lever to help start the engine. The position of the lever is dependent on whether the engine is cold or warm. See *Stopping and Starting the Engine* in Section 4 and the Engine Owner's Manual for details.

Engine On/Off Switch (A, Figure 2)

Use the ON/OFF Switch to start or stop the engine. See *Stopping and Starting the Engine* in Section 4 for details.

Engine Recoil Start Rope (F, Figure 2)

Use the recoil start rope to start the engine. See *Stopping and Starting the Engine* in Section 4 for details.

Throttle/Tines Control Lever (G, Figure 2)

Use the Throttle/Tines Control Lever to start and stop tine rotation. This lever also varies tine speed. Release the lever to stop all tine motion. See Section 4 for more details on this control.

Operation

⚠ WARNING

Before operating the unit, carefully read and understand all safety, control and operating instructions in this Manual, the separate Engine Owner's Manual and the decals on the machine.

Failure to follow these instructions can result in serious personal injury.

PRE-START PREPARATION

Before starting the engine, perform the following checks and services:

1. Disconnect the spark plug wire from the spark plug.
2. Move the engine On/Off switch to the OFF position.
3. Check that all wires and cables are properly and securely connected.
4. Check the six plastic cable ties (J, Figure 2). Be sure that cables and ties are positioned as shown. Cables must not be kinked or jammed in the handlebar.
5. Adjust handlebar height to desired position (see Section 2).
6. Check hardware for tightness.
7. Check engine oil level (see Engine Owner's Manual).
8. Check the air filter (see Engine Owner's Manual).
9. Adjust the tilling depth as follows:
 - a. Loosen tilling depth adjustment knob (A, Figure 3).

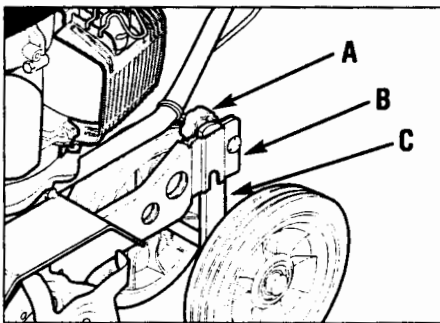

Figure 3

- b. Move wheel bracket (B, Figure 3) up in relation to height adjustment bar (C). Moving bracket upward results in shallower tilling, which is recommended for initial use.

IMPORTANT: Do not move the wheel bracket any higher than the top of the adjustment bar.

- c. Retighten the depth adjustment knob.

10. Reconnect the spark plug wire.

⚠ DANGER

GASOLINE IS HIGHLY FLAMMABLE AND ITS VAPORS ARE EXPLOSIVE.

Follow the gasoline safety rules in this Manual (Section 1) and in the separate Engine Owner's Manual.

Failure to follow gasoline safety instructions can result in serious personal injury and property damage.

11. Add gasoline to the fuel tank.

IMPORTANT: Read the separate Engine Owner's Manual before starting the engine. Never use stale or contaminated gasoline or oil/gas mix. The engine must be stopped and cool before adding gas.

Fill the fuel tank with unleaded gasoline (with a pump octane rating of 86 or higher) according to the directions in the separate Engine Owner's Manual. The engine is a vertical type, GX 31 model.

STOPPING AND STARTING THE ENGINE

Stopping the Engine

⚠ WARNING

Do not squeeze the Throttle/Tines Control Lever while starting engine.

Tines may propel the machine forward if the engine speed is advanced from idle. Failure to comply can result in personal injury or property damage.

To stop the engine, move the On/Off Switch (A, Figure 2) to the OFF position.

NOTE: The On/Off switch wire must be securely connected at both ends. Check regularly to ensure that the switch wire is securely connected to the switch and the engine.

Starting the Engine

NOTE: Do not squeeze Engine Throttle/Tines Control Lever (G, Figure 2) when starting engine.

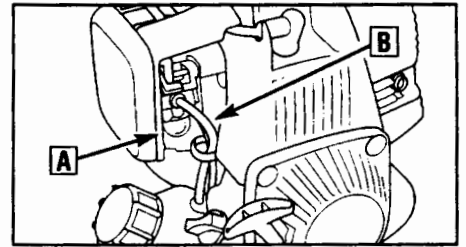

Figure 4: Primer bulb (A) and fuel-return tube (B).

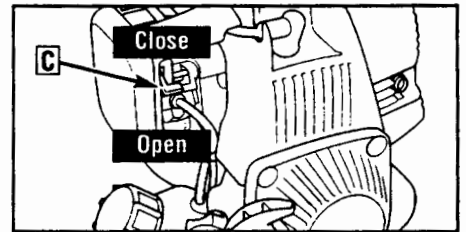

Figure 5: Choke lever.

1. Move the On/Off Switch (A, Figure 2) to the ON position.
2. To start a cold engine, move the choke lever (C, Figure 5) to the CLOSED position. To restart a warm engine, leave the choke lever in the OPEN position.
3. To start a cold engine, or after refueling an engine that has run out of fuel, press the priming bulb (A, Figure 4) repeatedly until fuel can be seen in the clear-plastic fuel-return tube (B). To restart a warm engine, it is not necessary to press the priming bulb.
4. Move to the starting position (Figure 6), keeping your feet positioned safely away from the tines.
5. Place one hand on the upper handlebar to stabilize the machine. Use the other hand to pull the recoil start rope lightly until you feel resistance, then pull briskly. Let the rope rewind slowly after each pull.

NOTE: An alternate stabilization method is to stand in the starting position (Figure 6), but place one hand on the carrying handle while pulling the starter rope with the other hand.

6. If the choke lever was moved to the CLOSED position to start the engine, gradually move it to the OPEN position as the engine warms up.

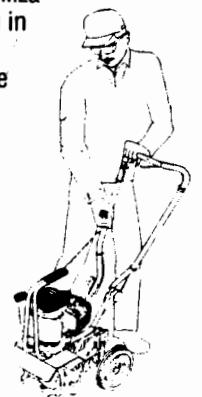

Figure 6

Section 4: Operation

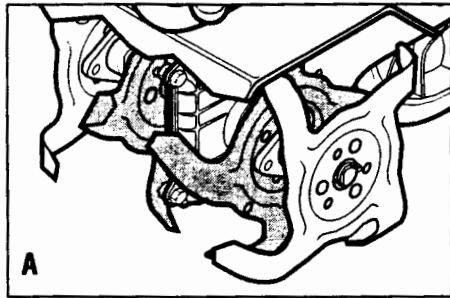

Figure 7: Tine patterns.

TILLING AND CULTIVATING

⚠ WARNING



Keep away from rotating tines. Rotating tines will cause serious personal injury.

Use your machine for busting sod, preparing seedbeds and for cultivating in gardens and flower beds. It is easy to operate, but it is important that you start out slowly and read this Section thoroughly before putting it to use. Let the machine do most of the work. The tines will pull the machine forward, letting you adjust forward speed by pressing down or lifting the handlebars.

1. Roll the machine to the work area.
2. Adjust the tilling depth to the desired position (see *Pre-Start Preparation* on the previous page).
3. Start the engine (see *Stopping and Starting the Engine* on the previous page). Stand behind the handlebar and push down on the bar to raise the tines off the ground. Squeeze the Throttle/Tines Lever – the engine should speed up and the tines start rotating. Release the Throttle/Tines Lever to return to idle, the tines should stop rotating or they may rotate very slowly. Lowering them back to the ground should stop any rotation.

NOTE: If tines continue to rotate when engine is idling, either the idle speed is too high or the centrifugal clutch is malfunctioning. If this occurs, contact the Factory or your local authorized dealer.

4. Squeeze the Throttle/Tines Lever to start the tines rotating. Lower the tines to begin tilling. Firmly hold the handlebar to prevent the machine from moving forward too quickly and to allow enough time for the tines to dig deeply enough.

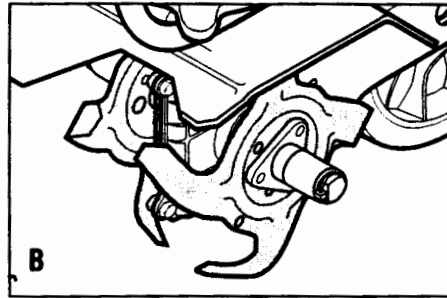

Adjust engine speed to suit the tilling conditions. Remember that the rotating tines help to pull the machine forward. Use slower speeds and a shallow depth setting when learning to use the unit and whenever you are tilling on hard, rough or uneven ground.

5. Do not try to till too deeply in the first pass through sod or very hard ground. If the machine jumps or bucks, use a shallower depth setting and reduce the engine speed. With each succeeding pass, till more deeply.
6. Apply downward pressure on the handlebars for shallower tilling. Lift the handlebars to dig more deeply. If the machine stays and tills in one spot, try swinging the handlebars from side to side to start it moving forward again.
7. For easier tilling, water very hard soil a few days before tilling. Avoid working the soil when soggy or wet. Wait a day or two after heavy rain for the ground to dry.

Cultivating

1. Cultivating is shallow tilling that disrupts weeds and aerates the upper crust of soil.
2. Do not till deeper than 1"-2" to avoid injuring nearby plant roots. Cultivate often, so that weeds do not grow large and cause needless tangling in the tines.
3. With careful planning, you can space the seed rows far enough apart to allow sufficient room for the machine to cultivate after the plants have grown.

Adjusting Tine Positions

Depending upon the tilling project, you have a choice of three tine patterns:

Wide (Standard) Tine Positions – As shipped from the factory, the unit is set up for general tilling and cultivating. This 10" wide tine pattern (the maximum tilling width) uses all four tine sections (A, Figure 7). See *Tine Removal and Installation* in Section 5 for detailed information on how to set up this tine position.

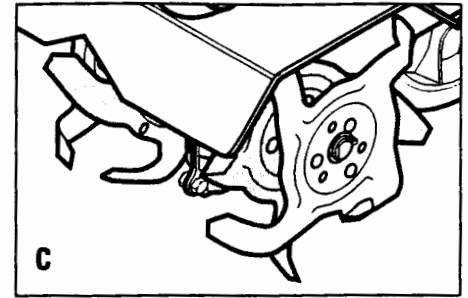

Narrow Tine Positions – For a narrow, 4-1/2" tilling width, remove the outside tine section on the left- and right-sides (B, Figure 7). See *Tine Removal and Installation* in Section 5 for detailed information on how to set up this tine position.

Stony Soil Tine Positions – When tilling deeply in stony soil, stones may become jammed between the inner tines and the machine hood. This setup swaps the two inner tines to minimize jamming (C, Figure 7). See *Tine Removal and Installation* in Section 5 for detailed information on how to set up this tine position.

Tilling Patterns

1. To make seedbeds, go over the same path twice in the first row, then overlap one-half the machine width on each successive pass until all rows are tilled twice (D, Figure 8).

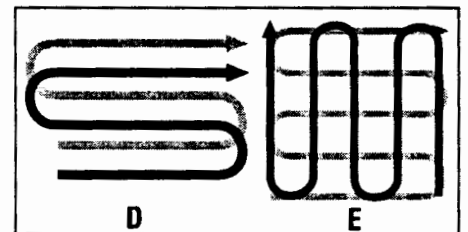

Figure 8: Recommended Tilling Pattern.

2. Make a second pass at a right angle across the original passes. Again, overlap each pass (E, Figure 8). Hard ground may take three to four passes before the desired depth is achieved.

NOTE: For small gardens, overlap by one-half (1/2) the machine width, followed by successive passes at one-quarter (1/4) machine width. This overlapping method assures thorough tilling.

Making Border Edges

Use the Edger Attachment to make clean, sharp edges next to walkways, driveways, paths, planted areas, patios, etc. See *Installing and Using the Edger Attachment*, in this Section, for detailed information.

INSTALLING AND USING THE EDGER ATTACHMENT

⚠ WARNING

Contact with rotating tines or other moving parts can cause serious personal injury.

Before installing or removing attachments, or adjusting or servicing the machine, stop the engine, let all moving parts come to a complete stop, disconnect the spark plug wire and move the wire away from the spark plug.

To create borders or edges near walks, driveways, flower beds, etc., you must remove the four tine sections and install the Edger Attachment (this attachment was supplied with the unit – see Section 3).

Installing the Edger Attachment

1. Gather together the following parts: Border/Edger Tine (A, Figure 10); Long Bushing (B); Border/Edger Wheel (C); and Short Bushing (D).

2. Prop the machine carefully onto the front of the tubular carrying handle. The work surface should be firm and flat. NOTE: Typically, the Border/Edger Tine is mounted on the right side of the unit for right-handed people, and on the left-side of the unit for left-handed people.

3. Flip open and remove the two ring lock pins (E, Figures 9 and 10) on each tine shaft.

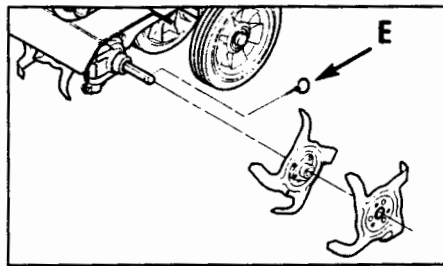

Figure 9: Ring lock pin and tines.

Keep left and right-side tines separate and marked for easier reinstallation.

IMPORTANT: The ring lock pin is under spring tension – use care when removing or replacing the ring lock pin.

4. It is important for proper tilling performance that the tine sections be later reinstalled in their original positions. Therefore, mark the position of each tine section (Left-Outer, Left-Inner, etc.) before removing them. Refer to Figure 7 for tine position information.

5. Install the short bushing (D, Figure 10) onto the tine shaft. Then place the Border/Edger wheel (C) onto the same shaft – the wheel hub should face toward the tiller. Insert the ring lock pin through the rounded side of the tine shaft and snap the ring down over the shaft (see “DETAIL”, Figure 10).

6. Slide the long bushing (B, Figure 10) onto the opposite side shaft. Then install the Border/Edger tine (A) and secure it with the ring lock pin.

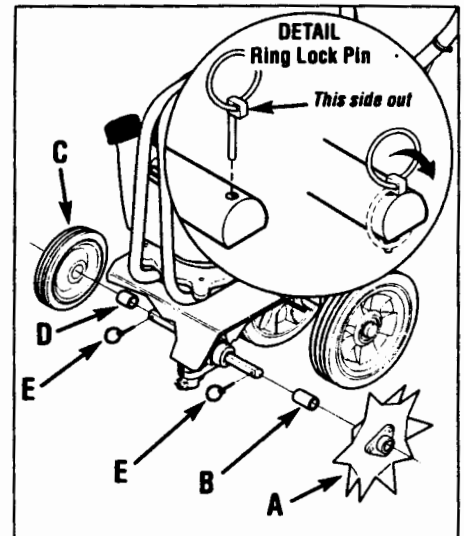

Figure 10: Border/Edger tine assembly.

Using the Edger Attachment

The Edger Attachment makes clean, sharp edges next to walkways, driveways, paths, planted areas, patios, etc.

Take your time when edging. Decide how far away to edge the walk or drive, then slowly proceed using the walk or drive as your sight line.



Attachments

The following Tiller/Edger attachments are available where the Tiller/Edger was purchased. See your local authorized dealer or contact the Factory for details.

Power Lawn Rake Attachment – Model OEM-290-263

The Power Lawn Rake helps to keep your lawn healthy and vigorous. Matted grass and debris looks unattractive and stifles lawn growth and overall health. This attachment mounts without tools and features dozens of tempered steel “fingers” that penetrate and loosen matted grass without disturbing root growth. An 18”-wide swath covers a large lawn area quickly.

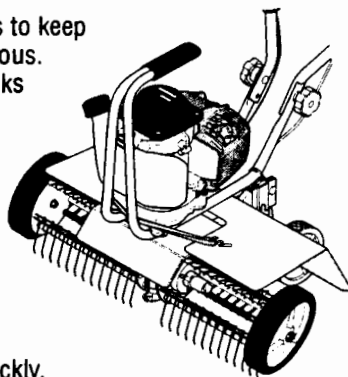

Lawn Aerator Attachment – Model OEM-290-264

The Lawn Aerator Attachment helps to promote healthy, dense lawns by loosening and aerating the soil for better root growth. Four tempered steel tines puncture the surface of the lawn thus allowing nutrients to reach the roots more easily. This attachment assembles without tools.

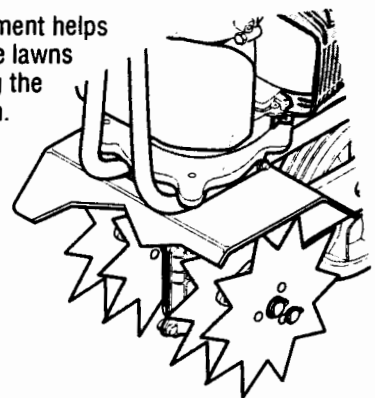

Maintenance

WARNING

Before inspecting, cleaning or servicing the machine, shut off engine, let all moving parts come to a complete stop, disconnect the spark plug wire and move the wire away from the spark plug.

Failure to follow these instructions can result in personal injury or property damage.

EQUIPMENT MAINTENANCE

Transmission Maintenance

The transmission was lubricated at the factory and should not require any further lubrication.

However, you should check the lubricant level after the first five (5) hours of operation and every twenty-five (25) operating hours thereafter. If needed, use a high-quality, automotive-grade petroleum-based grease.

WARNING

Before tipping engine or equipment to service transmission, drain fuel from tank by running engine until fuel tank is empty. Allow engine to cool.

To check the transmission:

1. Stop the engine, let it cool and disconnect the spark plug wire.
2. Place the machine down on its left side so the right end of the tine shaft faces up.
3. Remove the right-side tines (see *Tine Removal and Installation* in this Section).
4. Clean the transmission housing.
5. Remove the three threaded plugs (A, B and C, Figure 11) from the transmission.

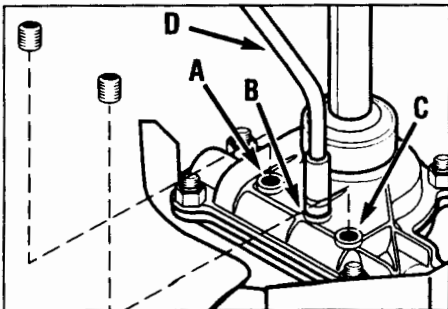

Figure 11: Transmission lubricant check and fill locations.

REQUIRED MAINTENANCE SCHEDULE

REQUIRED MAINTENANCE	Before Each Use	First month or 10 Hrs.	Every 3 months or 25 Hrs.	Every 6 months or 50 Hrs.	Yearly	Every 2 years
Perform at every indicated month or operating hour interval, whichever comes first.* See Engine Owner's Manual for engine related maintenance.						
Check Tightness of Bolts and Nuts	x					
Check Transmission Lubricant Level			x (1)		x	
Clean Machine					x	
Clean Tine Shaft	x					
Engine Oil Level	Check	x				
	Change		x	x		
Air Cleaner	Check	x				
	Change		x (2)			
Spark Plug	Check/Clean			x		
	Replace					x
Cooling Fins	Check			x		
Spark Arrester	Clean				x	
Fuel Tank	Clean				x	
Fuel Filter	Check				x	
Clutch Shoes	Check			x (3)		
Idle Speed	Check-Adjust				x (3)	
Valve Clearance	Check-Adjust					x (3)
Fuel Tubes	Check					Every 2 years (Replace if necessary) (3)

* For commercial use, log hours of operation to determine proper maintenance intervals.

(1) Check after first 5 hours of use.

(2) Service more frequently when used in dusty areas.

(3) Item should be serviced by your servicing dealer, unless you have the proper tools and are mechanically proficient.

Lubricant should be visible in the top two holes (B and C). If so, replace all three plugs. If lubricant is needed, proceed as follows.

To lubricate the transmission:

1. Place the nozzle (D, Figure 11) of a standard grease gun firmly against the rim of the middle hole (B) and add grease until it begins to seep from the bottom hole (A). Reinstall the plug in the bottom hole (A). Next apply grease to the top fill hole (C) until it begins to seep from the middle hole (B). Reinstall the plugs in the middle (B) and top (C) holes.

2. Before reinstalling the tines, use a fine grade sandpaper to clean any rust off the tine shaft. Apply a few drops of oil to the tine shaft to make future tine removal easier.

Other Lubrication Points

- Handlebar Adjustment Knobs: Spray occasionally with a silicone type lubricant.
- Throttle/Tines Control Lever Cable: Squeeze the lever closed and spray a lubricant into the cable area.
- Tine Shaft: After each use, remove the tines, clean the tine shaft with sandpaper and apply a light coat of oil to the tine shaft.

Hardware/Electrical Connections

Before each use, check that all hardware is tight and that the On/Off Switch wire connections are secure. Also check that the switch wiring is in good condition.

⚠ WARNING



Before inspecting, cleaning or servicing the machine, shut off engine, wait for moving parts to stop, disconnect spark plug wire and move wire away from spark plug.

Failure to follow these instructions can result in serious personal injury or property damage.

ENGINE MAINTENANCE

⚠ WARNING

The temperature of the muffler and adjacent engine areas may exceed 150°F (65°C). Contact may cause burns. Avoid these areas. Remove the spark plug lead and ground the lead to the engine to prevent accidental starts and fires.

Failure to do this could cause personal injury.

- Maintain the correct engine oil level and change the oil as recommended (more often in dusty conditions).
- Keep the air filter clean. Operating the engine with a dirty, clogged air filter can cause poor performance and damage to the engine. Never operate engine without air filter installed.
- Keep the spark plug clean and properly gapped. Replace every 2 years.
- The engine cooling fins must be kept clean to prevent overheating of the engine.

⚠ WARNING

Do not tamper with the engine governor screw which is factory-set for the proper engine speed. Overspeeding the engine beyond the factory high speed setting can be dangerous and will void the engine warranty. Authorized service shall be sought if a problem exists.

- If the engine is equipped with a spark arrester, clean it every year.
- Clean, check or adjust the following items according to the instructions in the Engine Owner's Manual: fuel tank, fuel filter, clutch shoes, idle speed, valve clearance and fuel tubes.

TINE REMOVAL AND INSTALLATION

The tines wear with use and should be replaced if tilling takes longer than usual or if the soil does not mix thoroughly. In addition to the standard 10" tilling width tine pattern, the tines can be arranged in a narrow, 4 1/2" tilling width pattern for smaller areas, and a special pattern for stony soil conditions.

⚠ WARNING

Avoid contact with the cutting edges on the tines.

To avoid personal injury when removing or installing tines, wear heavy work gloves. The engine must be off, all moving parts stopped, and the spark plug wire disconnected from the spark plug and moved away from the plug.

Arranging Tines for Narrow Tilling

1. Prop the machine forward so it rests on the front of the tubular carrying handle. The work surface should be flat and firm.
2. Flip open the ring (A, Figure 12) on the left side ring lock pin and remove the ring lock pin.

IMPORTANT: The ring lock pin (A, Figure 12) is under spring tension – use care when removing or replacing the ring lock pin.

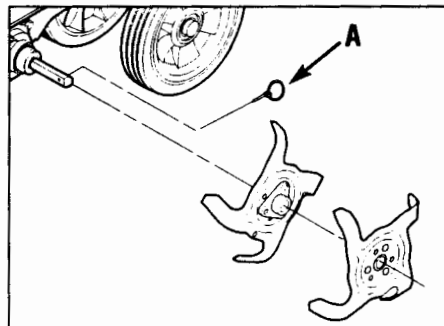

Figure 12: Standard wide tine pattern and ring lock pin location.

3. Remove the outer tine section (do not remove inner tine section) and mark it as to which side it is from (left or right) and whether it's an outer or inner tine section.
4. Slide one of the long bushings (B, Figure 13), provided with the unit, onto the shaft. Insert the ring lock pin through the rounded side of the tine shaft and snap the ring down over the shaft (see *DETAIL - Ring Lock Pin*, Figure 10, in Section 4).
5. Repeat this procedure on the opposite side.

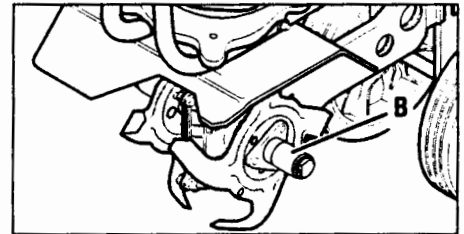

Figure 13: Narrow tilling tine configuration.

Arranging Tines for Stony Soil

1. Prop the machine forward so it rests on the front of the tubular carrying handle. The work surface should be flat and firm.
2. Remove the ring lock pin (A, Figure 12) from both sides of the unit. Remove both outer tine sections. Be sure to mark each section as a left or right side tine and whether it is an inner or outer section.
3. Remove the inner tine sections and swap their positions (the inner right-side section goes onto the left side of the machine, and the inner left-side goes onto the right side of the machine).

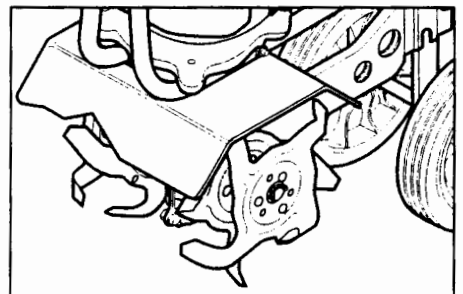

Figure 14: Stony soil tine pattern.

4. Reinstall the two outer tine sections onto the sides from which they were removed (Figure 14).
5. Insert the ring lock pins through the rounded side of the tine shafts and snap the rings down over the shafts (see *DETAIL - Ring Lock Pin*, Figure 10, in Section 4).

Section 5: Maintenance



WARNING

Before inspecting, cleaning or servicing the machine, shut off engine, wait for moving parts to stop, disconnect spark plug wire and move wire away from spark plug.

Failure to follow these instructions can result in serious personal injury or property damage.

Replacing Worn Tine Sections

The tines are excessively worn if tilling takes much longer than before and soil is not being mixed thoroughly enough.

1. Prop the machine forward so it rests on the front of the tubular carrying handle. The work surface should be flat and firm.
2. Remove the ring lock pin (A, Figure 12) from both sides of the unit. Remove the old tine sections and replace them with new tine sections. Refer to Figure 12 and the tine position shown in the *Parts List* for tine positioning details. Insert the ring lock pins through the rounded side of the tine shafts and snap the ring over the shaft (see *DETAIL - Ring Lock Pin*, Figure 10, in Section 4).

STORAGE

WARNING

- Never store your equipment when there is fuel in the fuel tank.
- Never place your equipment near any source of sparks or open flame (such as from a hot water heater, a space heater or clothes dryer).

Failure to comply can result in serious personal injury or property damage.

IMPORTANT: It is important to prevent gum deposits from forming in essential fuel system parts such as carburetor, fuel filter, fuel hose, or tank during storage. Also, experience indicates that alcohol-blended fuels (called gasohol or using ethanol or methanol) can attract moisture which leads to separation and formation of acids during storage. Acidic gas can damage the fuel system of an engine while in storage.

Off-Season Storage Procedure

- Protect the engine and perform recommended engine maintenance by following the engine storage instructions found in the separate Engine Owner's Manual.

NOTE: Be sure to protect the fuel lines, carburetor and fuel tank from gum deposits by removing the fuel or by treating the fuel with a stabilizer. See Engine Owner's Manual for more information.

- Remove tines. Clean all soil and debris from dust covers and tine shaft. Lubricate tine shaft with light oil. Replace tines.
- Cover engine and store equipment in a dry, sheltered location.

TROUBLESHOOTING

Before performing any of the corrections in this Troubleshooting Chart, refer to the appropriate information contained in this Manual and the Engine Owner's Manual for the correct safety precautions and servicing procedures. Contact your local authorized Engine Service Dealer for engine service. Contact your local authorized dealer for service problems with the machine.

PROBLEM	POSSIBLE CAUSE	CORRECTIVE ACTION
Engine does not start.	<ol style="list-style-type: none"> 1. Spark plug wire disconnected. 2. Out of gas. 3. Stale gas. 4. Priming/Choking procedure not correct. 5. Dirty air filter(s). 6. Worn, corroded or broken spark plug. 7. On/Off Switch in OFF position. 	<ol style="list-style-type: none"> 1. Reconnect wire to spark plug. 2. Check fuel tank. 3. Drain old gas. Replace with fresh gas. 4. Refer to Priming/Choking procedure and starting instructions in manual. 5. Clean or replace air filters. 6. Replace spark plug. 7. Move On/Off Switch to ON.
Engine runs poorly or has low power under tilling conditions.	<ol style="list-style-type: none"> 1. Fouled spark plug. 2. Dirty air filter(s). 3. Stale gas. 4. Carburetor malfunction/fuel filter clogged/ignition malfunction/valves stuck, etc. 	<ol style="list-style-type: none"> 1. Remove, inspect, clean spark plug. 2. Clean or replace dirty air filters. 3. Drain old fuel and replace with fresh fuel. 4. See authorized engine service dealer.
Engine overheats.	<ol style="list-style-type: none"> 1. Engine cooling system clogged. 2. Carburetor out of adjustment. 	<ol style="list-style-type: none"> 1. Remove debris. 2. See an authorized engine dealer.
Tines stop rotating.	<ol style="list-style-type: none"> 1. Object wedged between tines and hood. 2. Internal transmission problem. 	<ol style="list-style-type: none"> 1. Remove wedged object. 2. See an authorized engine dealer.

MANUFACTURER'S LIMITED WARRANTY FOR:



The limited warranty set forth below is given by Troy-Bilt LLC with respect to new merchandise purchased and used in the United States, its possessions and territories.

Troy-Bilt LLC warrants this product against defects for a period of two (2) years commencing on the date of original purchase and will, at its option, repair or replace, free of charge, any part found to be defective in materials or workmanship. This limited warranty shall only apply if this product has been operated and maintained in accordance with the Operator's Manual furnished with the product, and has not been subject to misuse, abuse, commercial use, neglect, accident, improper maintenance, alteration, vandalism, theft, fire, water, or damage because of other peril or natural disaster. Damage resulting from the installation or use of any accessory or attachment not approved by Troy-Bilt LLC for use with the product(s) covered by this manual will void your warranty as to any resulting damage.

Normal wear parts or components thereof are subject to separate terms as follows: All normal wear parts or component failures will be covered on the product for a period of 90 days regardless of cause. After 90 days, but within the two year period, normal wear part failures will be covered ONLY IF caused by defects in materials or workmanship of OTHER component parts. Normal wear parts and components include, but are not limited to: batteries, belts, blades, blade adapters, grass bags, rider deck wheels, seats, snow thrower skid shoes, shave plates, auger spiral rubber, tires.

HOW TO OBTAIN SERVICE: Warranty service is available, WITH PROOF OF PURCHASE, through your local authorized service dealer. To locate the dealer in your area, check your Yellow Pages, or contact Troy-Bilt LLC at P.O. Box 361131, Cleveland, Ohio 44136-0019, 1-866-840-6483, or log on to our Web site at www.troybilt.com.

This limited warranty does not provide coverage in the following cases:

- a. The engine or component parts thereof. These items carry a separate manufacturer's warranty. Refer to the applicable manufacturer's warranty for terms and conditions.
- b. Log splitter pumps, valves, and cylinders have a separate one year warranty.
- c. Routine maintenance items such as lubricants, filters, blade sharpening, tune-ups, brake adjustments, clutch adjustments, deck adjustments, and normal deterioration of the exterior finish due to use or exposure.

- d. Troy-Bilt LLC does not extend any warranty for products sold or exported outside of the United States, its possessions and territories, except those sold through Troy-Bilt LLC's authorized channels of export distribution.
- e. Parts that are not genuine Troy-Bilt parts are not covered by this warranty.
- f. Service completed by someone other than an authorized service dealer is not covered by this warranty.
- g. Transportation charges and service calls are not covered.

No implied warranty, including any implied warranty of merchantability of fitness for a particular purpose, applies after the applicable period of express written warranty above as to the parts as identified. No other express warranty, whether written or oral, except as mentioned above, given by any person or entity, including a dealer or retailer, with respect to any product, shall bind Troy-Bilt LLC. During the period of the warranty, the exclusive remedy is repair or replacement of the product as set forth above.

The provisions as set forth in this warranty provide the sole and exclusive remedy arising from the sale. Troy-Bilt LLC shall not be liable for incidental or consequential loss or damage including, without limitation, expenses incurred for substitute or replacement lawn care services or for rental expenses to temporarily replace a warranted product.

Some states do not allow the exclusion or limitation of incidental or consequential damages, or limitations on how long an implied warranty lasts, so the above exclusions or limitations may not apply to you.

In no event shall recovery of any kind be greater than the amount of the purchase price of the product sold. **Alteration of the safety features of the product shall void this warranty.** You assume the risk and liability for loss, damage, or injury to you and your property and/or to others and their property arising out of the misuse or inability to use the product.

This limited warranty shall not extend to anyone other than the original purchaser or to the person for whom it was purchased as a gift.

HOW STATE LAW RELATES TO THIS WARRANTY: This limited warranty gives you specific legal rights, and you may also have other rights which vary from state to state.