

Regulatory Approval

- FCC Class A
- UL 1950
- CSA C22.2 Number 950
- EN60950
- CE
 - EN55022 Class B
 - EN50082-1

Canadian EMI Notice

This Class A digital apparatus meets all the requirements of the Canadian Interference-Causing Equipment Regulations. Cet appareil numérique de la classe A respecte toutes les exigences du Règlement sur le matériel brouilleur du Canada.

European Notice

Products with the CE Marking comply with both the EMC Directive (89/336/EEC) and the Low Voltage Directive (73/23/EEC) issued by the commission of the European Community Compliance with these directives implies conformity to the following European Norms:

- EN55022 (CISPR 22) - Radio Frequency Interference
- EN50082-1 (IEC801-2, -3, -4) - Electromagnetic Immunity
- EN60950 (IEC950) - Product Safety

Five-Year Limited Warranty

MiLAN Technology warrants to the original consumer or purchaser that each of its products, and all components thereof, will be free from defects in material and/or workmanship for a period of five years from the original factory shipment date. Any warranty hereunder is extended to the original consumer or purchaser and is not assignable.

MiLAN Technology makes no express or implied warranties including, but not limited to, any implied warranty of merchantability or fitness for a particular purpose, except as expressly set forth in this warranty. In no event shall MiLAN Technology be liable for incidental or consequential damages, costs, or expenses arising out of or in connection with the performance of the product delivered hereunder. MiLAN Technology will in no case cover damages arising out of the product being used in a negligent fashion or manner.

Trademarks

© 2000 MiLAN, the MiLAN logo and MiLAN Technology are either trademarks or registered trademarks of Milan, Inc. in the United States and/or other countries. All other trademarks are the property of their respective holders.

To Contact MiLAN Technology

For prompt response when calling for service information, have the following information ready:

- Product serial number and revision
- Date of purchase
- Vendor or place of purchase

You can reach MiLAN Technology technical support at:

E-mail: support@milan.com
 Telephone: +1.408.744.2751
 Fax: +1.408.744.2771

MiLAN Technology

29 Moffett park Dr
 Sunnyvale, CA 94089-1138
 United States of America
 Telephone: +1.408.744.2775
 Fax: +1.408.744.2793

http://www.milan.com
 support@milan.com

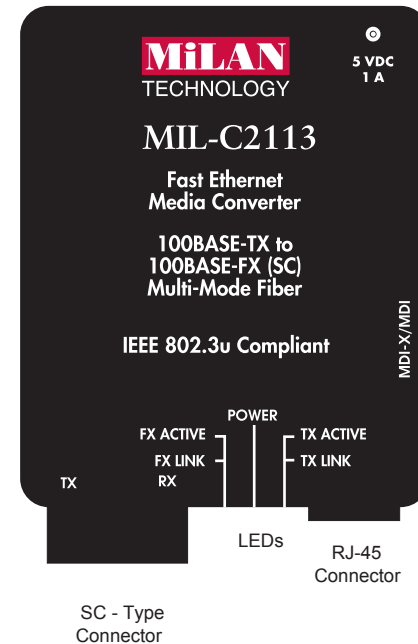

The MIL-C2113 comes equipped with SC-type connectors and supports Fast Ethernet in both half and full-duplex mode. For network budget constraint, the MIL-C2113 uses 150 nanoseconds (approximately 30 meters of cable) during conversion in each direction.

To maximize the fiber cable distance, use one meter of CAT 5 UTP cable when connecting directly to a node (subject to fiber budget of 16dBm and collision domain restrictions). In full-duplex environments, use up to 100m of CAT 5 UTP and:

- 2Km of multi-mode optical fiber for MIL-C2113;
- 15Km of single-mode optical fiber for MIL-C2113-15;
- 40Km of single-mode optical fiber for MIL-C2113-40;
- 70Km of single-mode optical fiber for MIL-C2113-70;
- 100Km of single-mode optical fiber for MIL-C2113-100.

- | | | |
|--|---|--|
| Multi-mode fiber <ul style="list-style-type: none"> • 1300nm wavelength • 62.5/125 micron diameter • -14 dBm launch power • -31 dBm receive sensitivity | Single-mode fiber (15Km) <ul style="list-style-type: none"> • 1300nm wavelength • 9/125 micron diameter • -8 dBm launch power • -31 dBm receive sensitivity | Single-mode fiber (40Km) <ul style="list-style-type: none"> • 1300nm wavelength • 9/125 micron diameter • -5 dBm launch power • -34 dBm receive sensitivity |
| Single-mode fiber (70Km) <ul style="list-style-type: none"> • 1300nm wavelength • 9/125 micron diameter • -4 dBm launch power • -37 dBm receive sensitivity | Single-mode fiber (100Km) <ul style="list-style-type: none"> • 1300nm wavelength • 9/125 micron diameter • -3 dBm launch power • -37 dBm receive sensitivity | |

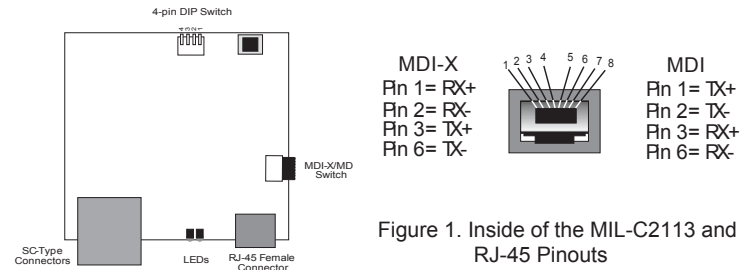

Figure 1. Inside of the MIL-C2113 and RJ-45 Pinouts

Installation

1. Attach a UTP cable from the network to the RJ-45 port. (Use screened UTP cabling for CISPR 22 class B installation.)
2. Cross-connect the fiber cables: Attach both fiber cables TX to RX and RX to TX from the fiber network cabling to the ST-type connectors on the MIL-C2113.
3. Apply power to the unit:
 - A. Insert the power adapter's receptacle into the power plug.
 - B. Insert the power adapter into a wall outlet.

Diagnostic LEDs and Conditions Indicated

There are five LEDs, including power and:

- TX/ACTIVE: Receiving packets from the 100BASE-TX port.
- FX/ACTIVE: Receiving packets from the 100BASE-FX port.
- TX/LINK: An active connection on the 100BASE-TX port.
- FX/LINK: An active connection on the 100BASE-FX port.

MDI-X/MDI Switch

The MDI-X/MDI switch allows for quick configuration of the 100BASE-TX port. Cables used when the switch is in the MDI-X position (the "left" position):

- For a hub/repeater use a swap cable (pins are connected 1 to 3, 2 to 6, 3 to 1, and 6 to 2).
- For a workstation/PC, use a straight-through cable (pins are connected 1 to 1, 2 to 2, 3 to 3, and 6 to 6).

Cables used when the switch is in the MDI position (the "right" position):

- For a hub/repeater use a straight-through cable (pins are connected 1 to 1, 2 to 2, 3 to 3, and 6 to 6).
- For a workstation/PC, use a swap cable (pins are connected 1 to 3, 2 to 6, 3 to 1, and 6 to 2).

Note: The MIL-C211X media converters operate at full duplex. Therefore, when connecting the Copper UTP port, be sure to force the link partner to 100 Full duplex. Failure to force link partner may result in a duplex mismatch when connecting to an auto negotiating device.

Link Sentry Configuration

The Link Sentry feature on the MIL-C2113 is configured through a 4-position DIP switch (refer to Table 1).

Link Sentry is a troubleshooting feature that allows MiLAN media converters to monitor link states on both fiber and copper ports in the event of a physical link down. If a link down is detected, the converter will automatically notify the end device of the link down by disabling the TX signal of the neighboring port. (see Figure 2.)

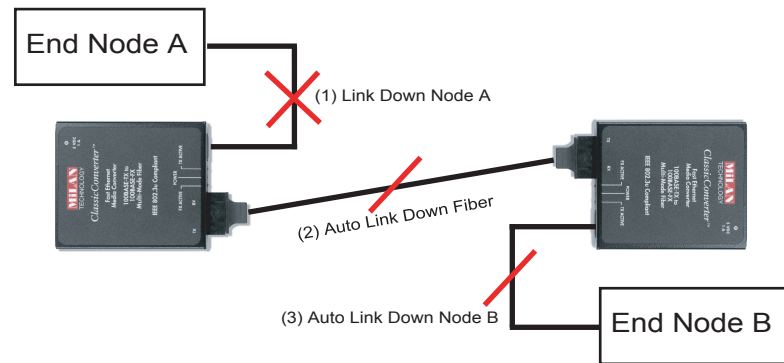

Figure 2. Link Sentry Back to Back Configuration

Note: When connecting two MIL-C211X series converters back to back via fiber, Dip Switches 1 & 2 should be in the "up" and 3 & 4 should be in the "down" position.

The following table displays the Link Sentry dip switch settings needed when the MIL-C211X is installed in a single media converter environment (not back to back).

Table 1. Single Converter Link Sentry Settings

Switch	UP	Down	Function
1	Fiber TX to RX Link Sentry Disabled	Fiber TX to RX Link Sentry Enabled	Fiber TX link down causes Fiber RX to link down
2	N/A	N/A	Reserved, must remain in up position
3	Copper to Fiber Link Sentry Disabled	Copper to Fiber Link Sentry Enabled	Copper link down causes Fiber link down
4	Fiber to Copper Link Sentry Disabled	Fiber to Copper Link Sentry Enabled	Fiber link down causes Copper link down