

ATTACHMENT OPERATOR'S MANUAL

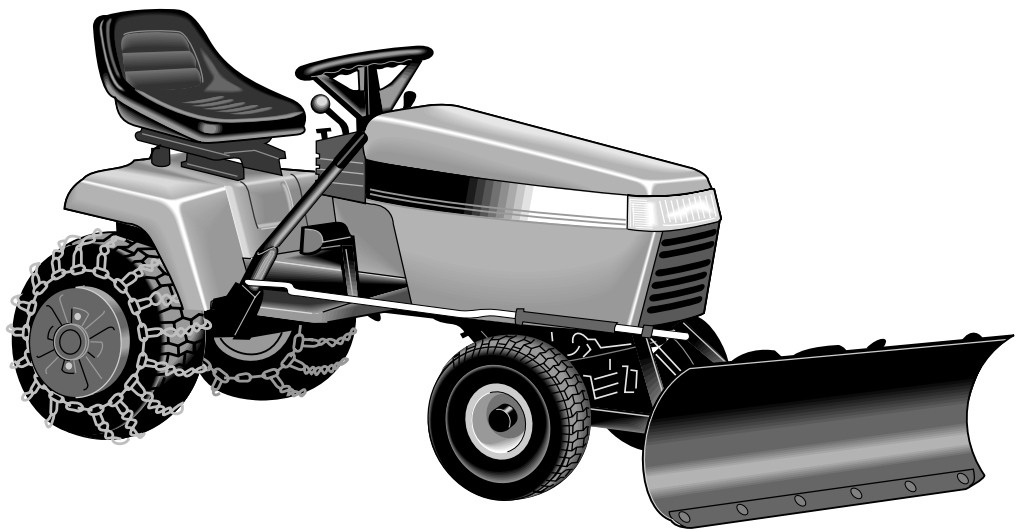

Snow/Dozer Blade & Hitch

Snow Plow/Dozer Blade

Mfg. No.	Description
1693754	42" Remote Angling Snow Plow/Dozer Blade

Hitch

Mfg. No.	Description
1693756	Hitch (for Baron Series, Broadmoor / 1600 / 2600 Series, & Landlord / 1700 / 2700 Series)

1721302-04

Rev 1/2001

TP 100-2356-04-AT-SMA

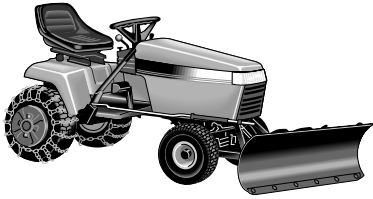

Table of Contents

Recommended Accessories	1	Adjustments.....	7
Safety Rules & Information		Skid Shoe Adjustment	7
General Warnings.....	2	Spring Tension.....	7
Operating on Slopes.....	2	Lift Height Adjustment	8
Preparation	2	Downward Pressure Adjustment	8
Operating Safety.....	2	Initial Setup & Assembly	
Features & Controls	3	Dozer Components.....	9
Blade Angle Control.....	3	Hitch Components	10
Manual Attachment Lift Lever	3	Assemble Blade.....	11
General Operating Instructions		Install Rear Pushbar Support	12
Checks Before Starting.....	4	Install Hitch	12
Engine & Ground Speed Selection.....	4	Install Pivot Hitch	13
Transporting.....	4	Install Spring Assist Bracket	14
Starting & Stopping	4	Install Dozer Blade	14
Changing Angle of the Blade.....	5	Install Lift Rod.....	15
Dozing Tips.....	5	Install Angling Control Rod	16
Snow Plowing Tips	5	Attaching & Removing the Hitch & Blade	
Storage	5	Removing & Attaching Dozer Blade	17
Maintenance & Normal Care Schedule.....	6	Removing & Attaching Hitch.....	18
Schedule for Normal Care	6	Reinforcement Bracket Installation	19
Lubricate the Dozer Blade	6	Hardware Identification	
		& Torque Specifications.....	20

NOTE: In these instructions, "left" and "right" are referred to as seen from the operating position.

Recommended Accessories

For best performance, it is recommended to use tire chains and two rear wheel weights. A rear-mounted weight box can also be added for additional traction. The maximum weight added to the tractor should not exceed 35 lbs. per wheel, plus 100 additional pounds in the rear weight box.

For operation on slopes greater than 15% (8.5°), Quick Tach Weights, tire chains, and wheel weights are recommended. Never operate on slopes greater than 17.6% (10°).

Required Accessories

A Lift Lever Kit is required for some of the models covered by this manual, and must be installed as part of hitch installation.

Safety Rules & Information



Read these safety rules and follow them closely. Failure to obey these rules could result in loss of control of unit, severe personal injury or death to you, or bystanders, or damage to property or equipment.

The triangle  in text signifies important cautions or warnings which must be followed.

GENERAL WARNINGS

- Know the tractor controls and how to stop quickly. **READ THE TRACTOR OPERATOR'S MANUAL.**
- Read this manual and the tractor Operator's Manual carefully. Be thoroughly familiar with the controls and the proper use of the equipment.
- Never allow children to operate the machine. Do not allow adults to operate it without proper instruction.
- Do not carry passengers.
- Use only attachments or accessories designed for your machine. See your dealer for a complete list of recommended attachments or accessories.
- Keep the area of operation clear of all persons, particularly small children, and pets.
- Never direct discharge towards bystanders.
- Make sure all hardware is secure and that dozer blade is in good operating condition.
- Check to be sure all safety devices and shields are in place.
- Check that all adjustments are correct before using this unit.
- Gasoline is highly flammable. Follow all precautions listed in your tractor's operator's manual.
- Always wear eye protection while operating and performing adjustments to protect eyes from debris thrown by the dozer.
- When cleaning, repairing, or inspecting the unit make sure all moving parts have stopped. Disconnect and secure the spark plug wires and remove the key to prevent accidental starting.

DANGER

OPERATING ON SLOPES CAN BE DANGEROUS

For operation on slopes greater than 15% (8.5°), weight box, tire chains, and wheel weights are recommended. **NEVER OPERATE ON SLOPES GREATER THAN 17.6% (10°).**

PREPARATION

- Disengage the PTO before making any adjustments.
- Never attempt to make any adjustments while engine is running.
- Thoroughly inspect the area where the dozer is to be operated and remove all foreign objects.
- Adjust the skid shoe height to clear gravel or crushed stone surface. See the Adjustments section for procedure.

OPERATING SAFETY

- Always clear snow up and down the face of slopes, never across the face. Exercise extreme caution when changing direction on slopes. Do not attempt to clear steep slopes.
- Exercise extreme caution when operating on, or crossing, gravel drives, walks or roads. Stay alert for hidden hazards or traffic.
- After striking an object or if unit starts to vibrate abnormally, stop the engine and remove the key. Check for the cause and any damage before restarting. Before any inspection, make sure all moving parts have stopped.
- Take all possible precautions before leaving operator's position. Lower the attachment, set the parking brake, stop the engine and remove the key.
- Never operate near glass enclosures, automobiles, window wells, dropoffs, etc.
- Do not put hands or feet near or under the dozer blade. Keep clear of the dozer blade at all times.
- Do not overload machine capacity by attempting to clear too much material at too fast a rate.
- Never operate unit at high transport speeds on slippery surfaces. Use care when travelling in reverse.
- Never operate the dozer blade without good visibility or light. Always be sure your feet are properly placed on the footrests and keep a firm hold on the steering wheel.
- Do not run the engine indoors.
- Never allow anyone in front of the unit.

CONTROL FUNCTIONS

The information below briefly describes the function of individual controls. Operating the tractor and dozer require the combined use of these controls and additional controls whose operation is described in the tractor Operator's Manual.

Please take a moment and familiarize yourself with the name, location, and function of these controls so that you will better understand the safety and operating instructions provided in this manual.

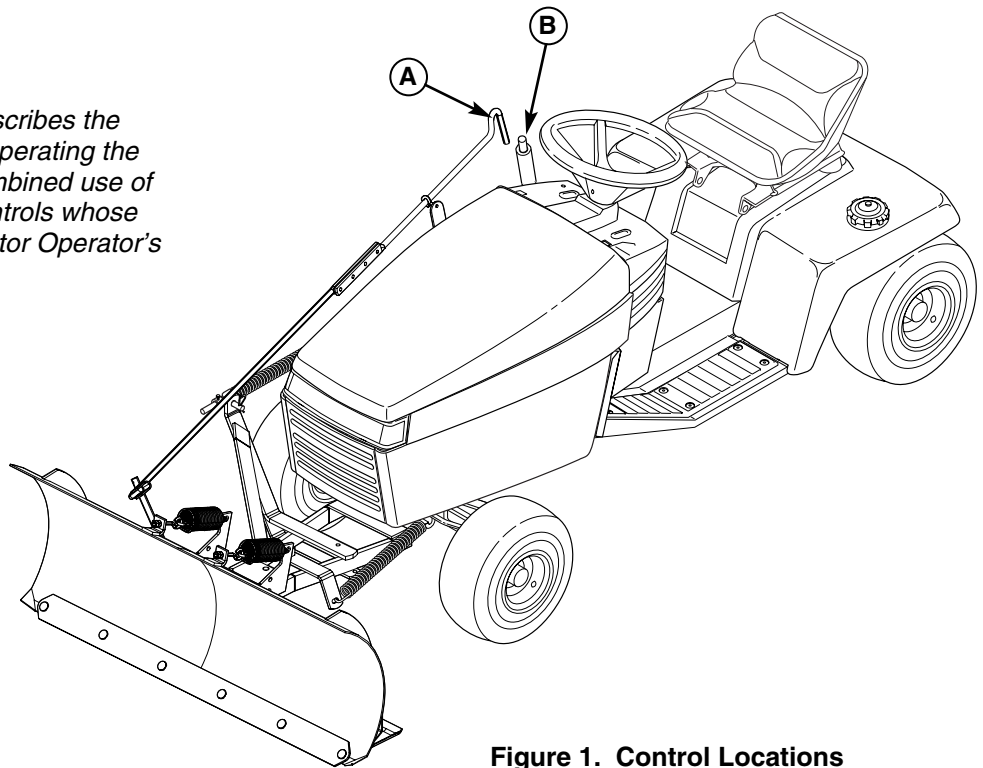

Figure 1. Control Locations
A. Blade Angle Control Lever
B. Manual Attachment Lift Lever

A. Blade Angle Control Lever

The blade angle release lever controls a spring-loaded plate which locks the blade in one of three positions.

Use an abrupt pushing/pulling motion to release the angling mechanism and move the blade left or right. Push the angling lever forward fully to lock the blade in the left position. Pull the lever fully back to lock the blade in the right position. Move the lever slowly past center to lock in the centered position.

NOTE: It is easier to change the angle of the blade with the attachment raised.

B. Manual Attachment Lift Lever

NOTE: Models with hydraulic or electric lift should refer to the tractor operator's manual for lift control information.

The attachment lift lever raises and lowers the dozer blade. To RAISE an attachment, depress the release button on top of the lever and pull back. To LOWER an attachment, depress the release button and move the lever forward.

The back notch suspends the blade for transporting to and from the work site. The middle notch is the "float" position. The front notch applies downward pressure on the blade. See the Adjustments section for proper blade adjustment.



TRACTOR CONTROLS

Before you begin operating the tractor with the dozer blade attachment, make certain you have:

- **Read and understood the instructions in the tractor Operator's Manual.**
- **Become thoroughly familiar with all of the tractor controls and their operation, including how to safely and properly start and stop the unit.**
- **Practice driving in an open area—without dozing—to become accustomed to the unit.**

General Operating Instructions



Checks Before Starting

1. Refer to the Maintenance & Adjustments sections of this manual and perform any needed service. Also, refer to the tractor Operator's Manual and perform any required service.
2. Remove any objects from the work area which might interfere with plowing activity.
3. Adjust the skid shoes to desired height. See Skid Shoe Adjustment.
4. Make sure all hardware is present and secure.

Engine & Ground Speed Selection

Always run the engine at full throttle.

Set tractor speed to obtain the needed power to move the material. Operate at a safe speed, depending on conditions, so that you have complete control of the tractor. Rear wheel weights and chains are recommended for slippery surfaces.

A weight box is recommended for additional traction.

Transporting

For maximum ground clearance, transport the blade to and from work areas fully raised and angled straight ahead.

Starting & Stopping

1. Start the tractor engine. Set engine throttle to full.
2. Raise the attachment lift and travel to the work site.
3. Set the angling control to the desired angle.
4. Lower the attachment lift and begin plowing.
5. Raise the plow before backing up.
6. To stop the tractor, set ground speed to neutral and set the parking brake. Before leaving the seat, stop the engine, set the parking brake, remove the key, and wait for all moving parts to stop.

WARNING

Perform the Safety System Interlock test found in your tractor Operator's Manual. If tractor does not pass the test, do not operate the tractor. See your authorized dealer. Under no circumstances should you attempt to defeat the safety system.

Use caution when plowing a snow covered area. Snow can cover objects such as curbs, drop-offs, and other obstacles. Be familiar with the area you are plowing.

To prevent an explosion or fire, never store the tractor with fuel in the tank inside a building where an ignition source is present.



IMPORTANT NOTE

To prevent damage to the unit, always raise the dozer blade BEFORE turning or backing up.

DANGER

OPERATING ON SLOPES CAN BE DANGEROUS

Never operate on slopes greater than 17.6% (10°) which is a rise of 3-1/2 feet (106cm) vertically in 10 feet (607cm) horizontally.

Operate the unit at a slow ground speed when driving onto slope. Avoid using brakes to control ground speed.

When operating on slopes that are greater than 15 % (8.5°) but less than 17.6%, use additional wheel weights or counterweights.

In addition to counterweights, use extra caution when operating on slopes. Drive UP and DOWN the slope, never across the face, use caution when changing directions and **DO NOT START OR STOP ON SLOPE.**

For additional traction, tire chains and a weight box can be added. Maximum weight added to tractor should not exceed 35 lbs. per wheel and 100 additional lbs. in weight box.

Changing Angle of the Blade:

See Figure 1 for location of Controls.

NOTE: It is easier to change the angle of the blade with the attachment raised.

1. Raise the attachment lift.
2. Use an abrupt pushing/pulling motion to release the angling mechanism and move the blade left or right. Push the angling lever forward fully to lock the blade in the left position. Pull the lever fully back to lock the blade in the right position. Move the lever slowly over center to lock in the centered position.

Dozing Tips

- Determine the best dozing pattern before beginning.
- When land contour permits, it is best to travel in the longest direction to minimize turning.
- In very deep snow or gravel, it may be necessary to make the first pass with dozer blade partially raised, then repeat each pass with the blade lowered to clear the material left on the surface. Also, it may be necessary to clear less than the full width of the dozer blade or reduce ground speed.
- When dozing, push the dirt to the desired location, then drag the blade backwards for final leveling. Pack down the dirt or gravel by driving the tractor over the leveled area.
- Use any slight grade to your advantage, doze downhill, and set the blade angle so that the plowed material is moving downhill as it leaves the blade.

Snow Plowing Tips

- Determine the best snow removal pattern before beginning.
- Plan the pattern so that you avoid pushing snow onto cleared areas.
- When land contour permits, it is best to travel in the longest direction to minimize turning.
- In very deep or heavy snow, it may be necessary to make the first pass with dozer blade partially raised, then repeat each pass with the blade lowered to clear the material left on the surface. Also, it may be necessary to clear less than the full width of the dozer blade or reduce ground speed.
- Snow tends to freeze into solid banks when plowed off a driveway or other large area. Because of this you may want to plow snow several feet past the edge of the drive to allow space for future plowing to build up.
- If pushing snow past the edges of driveways or sidewalks, be careful not to tear up the grass buried under snow next to the drive or sidewalk. Lift the blade several inches off the ground to avoid damaging the grass.
- Spinning tires with tire chains can leave unsightly marks or permanent damage to asphalt or concrete driveways or sidewalks. Avoid sudden stops or starts.

Storage



IMPORTANT NOTE
Refer to Tractor Operator's Manual for important information concerning safely storing your tractor.

Daily Storage

1. Allow tractor engine to cool before storing in any enclosure.
2. After dozing or plowing jobs are completed, hose or brush down the blade to remove excess dirt.
3. Lightly oil all pivot points. Coat bare metal surfaces to prevent corrosion.

Off-Season Storage

1. Remove dozer blade and hitch from the tractor.
2. Use water pressure or a brush to thoroughly clean the dozer blade.
3. Paint, or lightly coat with oil, any area where paint has been worn or chipped away.
4. Lubricate the dozer blade.
5. Store the dozer blade and hitch in a dry place.

⚠ WARNING

To avoid serious injury, perform maintenance on the tractor or dozer blade only when the engine is stopped, parking brake is set and all moving parts have stopped. Always remove the ignition key before beginning maintenance or adjustments to prevent accidental starting of the engine.

Lubricate Dozer Blade

Lubricate the dozer blade as shown in Figure 2. Where an oil can is shown, wipe the area clean, apply a few drops of oil (SAE 30), then wipe up drips or spills.

In general, linkage connections and other parts that have partial rotational or sliding movement should be lubricated periodically with SAE 30 weight oil. Avoid applying excessive amounts of oil since this may cause a build-up of dirt around the lubricated area, making subsequent lubrication more difficult to accomplish.

Schedule For Normal Care

Care Required	Schedule
Clean debris from dozer blade.	After each use.
Lubricate dozer blade.	Every 10 hours or at least once a year.

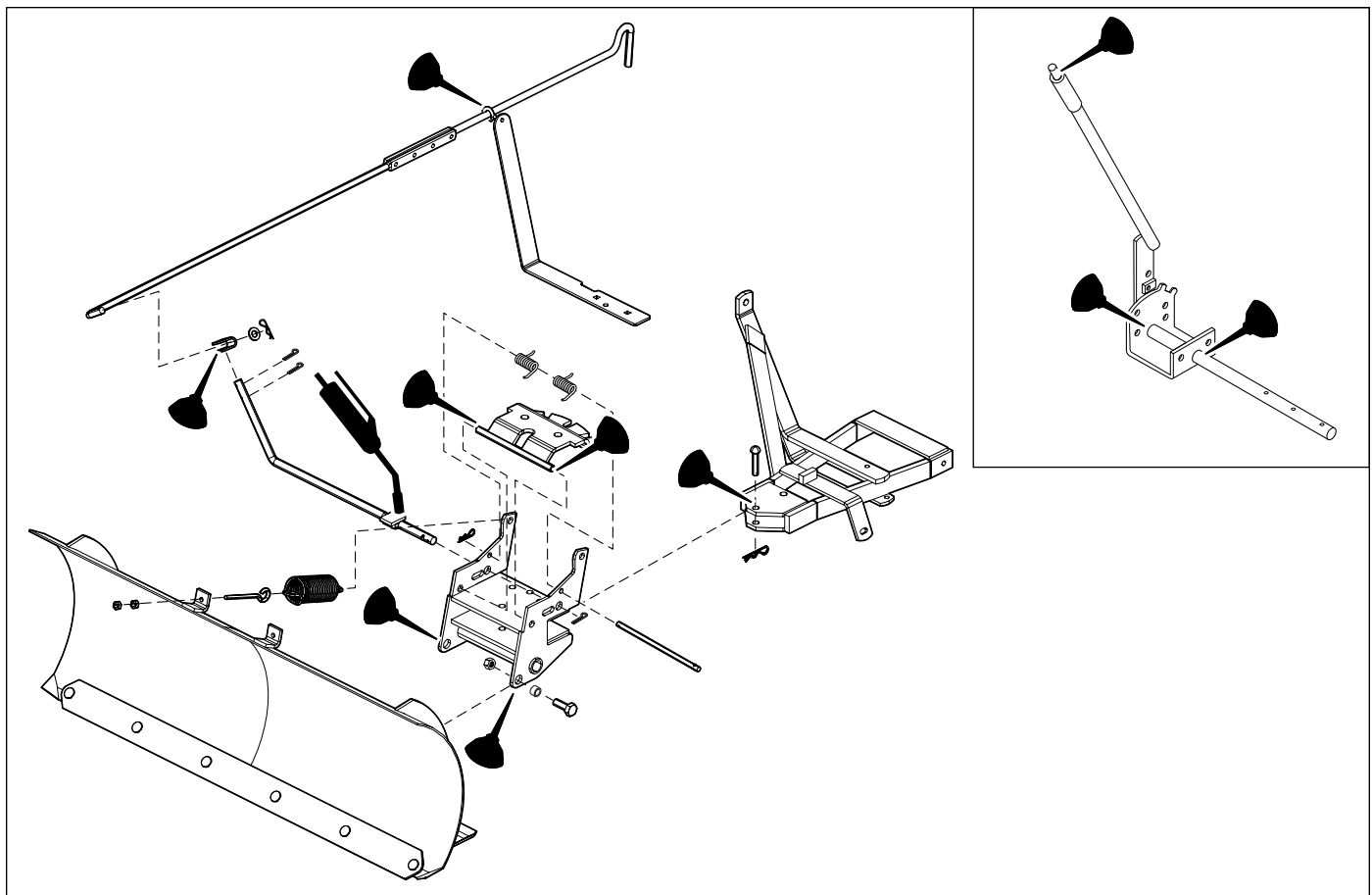

Figure 2. Lubrication Points

Skid Shoe Adjustment

Slotted holes are provided to permit adjustment of the shoe assemblies for raising and lowering the blade to various working heights (see Figure 3).

When cleaning snow from gravel or earth drives or walks, the shoe assemblies should be lowered fully to prevent blade contact with gravel or ground. When cleaning smooth hard surfaces like concrete, the shoe assemblies are normally placed fully up to allow the blade to scrape the surface.

To adjust the skid, raise the blade off the ground and block with a piece of wood. Loosen the bolts (B, Figure 3) and move the skid shoes (A) up or down to desired height. Tighten the bolts securely.

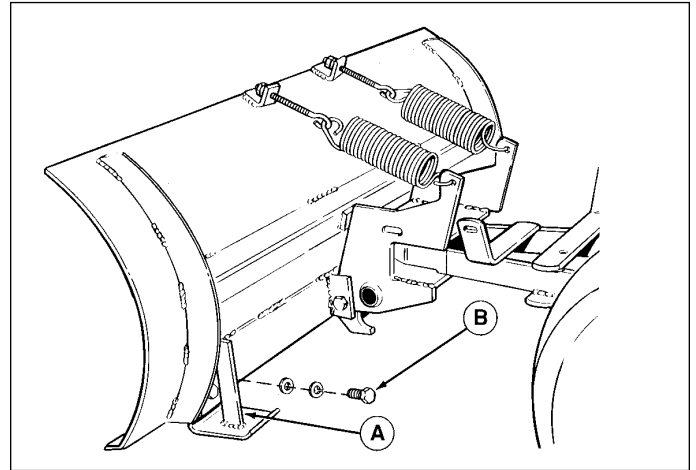

Figure 3.
A. Skid Shoes
B. Bolts

Spring Tension

See Figure 4. This snow plow/dozer blade is spring loaded so that when the blade strikes a solid object, the springs will allow the blade to release as shown, rather than cause damage. The blade will go back to its original position after object is cleared.

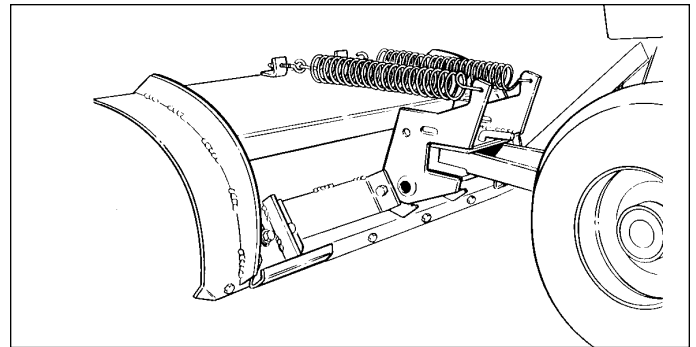

Figure 4. Dozer Blade "Released"

See Figure 5. To adjust spring tension hold rear nut (B) and loosen front nut (E). Tighten rear nut (B) to increase spring tension, or loosen to decrease tension.

For initial adjustment, tighten nut (B) on each eyebolt enough to expose about 3/4" (19mm) of thread. Tighten front nut (E) against rear nut (B) to lock adjustment in place.

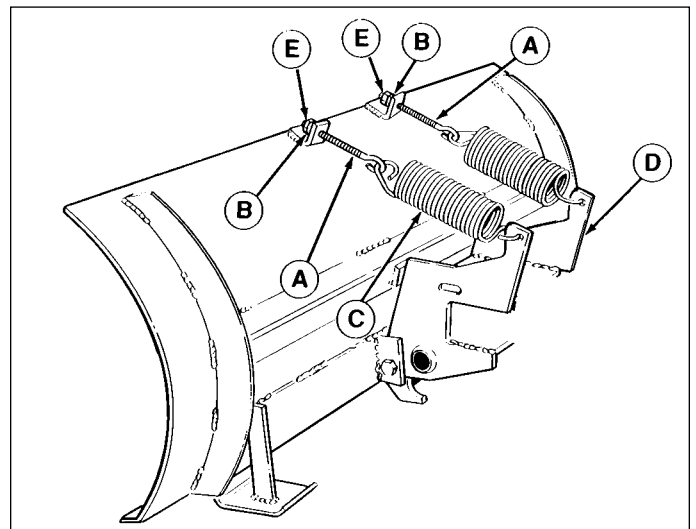

Figure 5. Tension Springs
A. Eyebolt
B. Nut, 5/16
C. Spring
D. Pivot Frame
E. Nut, 5/16

Adjustments

Lift Rod Adjustment

ELECTRIC/HYDRAULIC LIFT MODELS:

In the fully raised position the blade should be 6" off the ground. In the fully lowered position, the lift rod should slightly compress the spring creating downward pressure on the blade.

NOTE: Always adjust the lift height before and after adjusting the downward pressure.

MANUAL LIFT MODELS

The lift lever can be placed in one of three notches and is held in position by the lever latch. (see Figure 7). When the lever latch is placed in notch 1 the lift lever should be applying downward pressure on the attachment. In position 2, the "float" position, the attachment should experience negligible upward or downward pressure. Position 3 should raise the attachment approximately 6" above the ground.

NOTE: Always adjust the lift height before and after adjusting the downward pressure.

LIFT HEIGHT ADJUSTMENT

1. Place the lever latch in notch 3 (see Figure 7). The snowthrower should be approximately 6" off the ground. If not, go to step 2.
2. Lower the snowthrower and adjust the front set collar (A, Figure 6) to achieve the correct lift height.

DOWNWARD PRESSURE ADJUSTMENT



IMPORTANT NOTE

DO NOT OVER-COMPRESS THE SPRINGS. In addition to providing downward pressure, the springs are an elastic medium that absorbs shocks caused by bumps and cracks in ground surfaces. Over-compressing the springs defeats this and may cause damage to the unit.

1. Move the lever latch from notch 2 to notch 1 (See Figure 7) or place the hydraulic/electric lift in the fully lowered position.
2. The spring (C, Figure 6) should be slightly compressed applying downward pressure to the attachment. If not, adjust the rear set collar (D, Figure 6) to achieve the desired amount of downward force. Do not over-compress the lift rod spring.

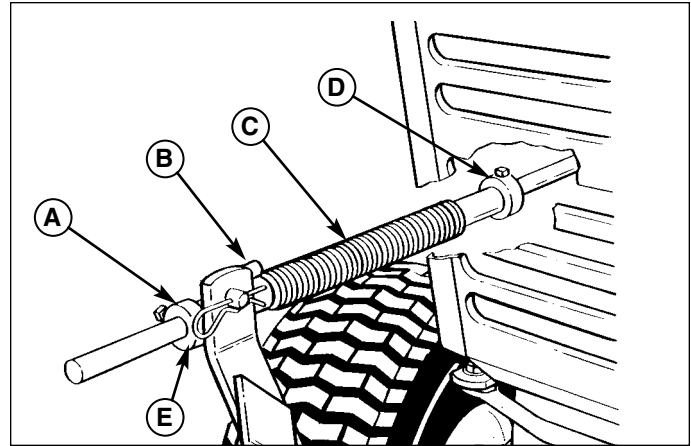

Figure 6. Adjusting Lift Rod

- A. Front Set Collar
- B. Rod Guide
- C. Spring
- D. Rear Set Collar
- E. Spring Clip

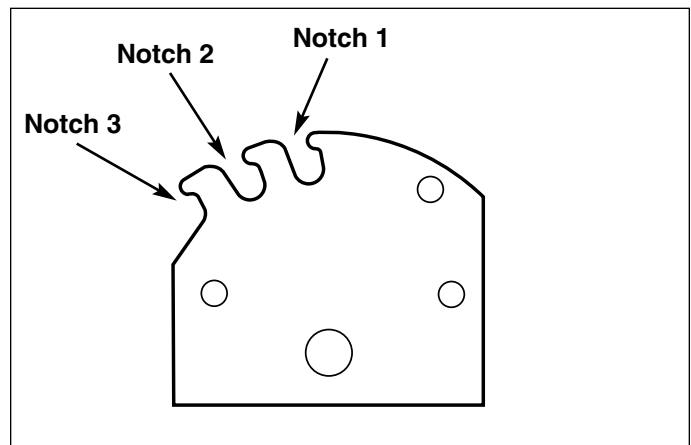

Figure 7. Lift Lever Quadrant - Side View

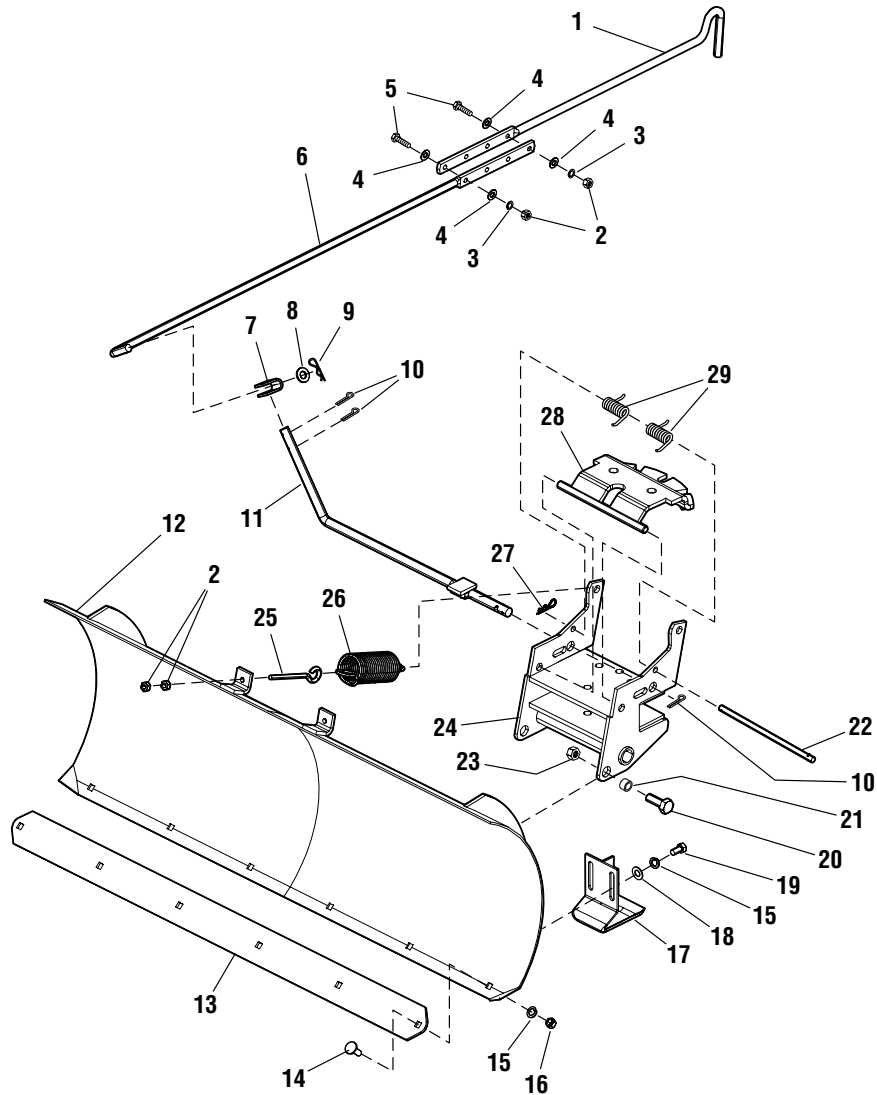

Figure 8.

Ref	Qty	Description	Ref	Qty	Description
1	1	ROD, Control Handle, Upper	16	6	NUT, Hex, 3/8-16
2	6	NUT, Hex, 5/16-18	17	2	SKID SHOE
3	2	LOCKWASHER, 5/16	18	4	WASHER, Plain, 3/8
4	4	WASHER, 5/16	19	4	CAPSCREW, 3/8-16 x 3/4
5	2	CAPSCREW, 5/16-18 x 1-1/4	20	2	CAPSCREW, 1/2-13 x 1-1/2
6	1	ROD, Control Handle, Lower	21	2	SPACER, 1/2 ID x 3/4 OD x 5/16 LG
7	1	CLEVIS	22	1	ROD, Latch Stop
8	1	WASHER, 1/2	23	2	LOCKNUT, 1/2-13
9	1	CLIP, Hair Pin	24	1	FRAME ASMY, Dozer
10	3	COTTER PIN	25	2	EYEBOLT
11	1	ROD & PLATE ASMY, Pivot	26	2	SPRING, Extension
12	1	DOZER BLADE ASMY, 42"	27	1	CLIP, Hair Pin
13	1	SCRAPER BAR	28	1	PLATE ASMY, Latch
14	6	CARRIAGE BOLT, 3/8-16 x 1	29	2	SPRING, Torsion
15	10	LOCKWASHER, 3/8			

Initial Setup & Assembly

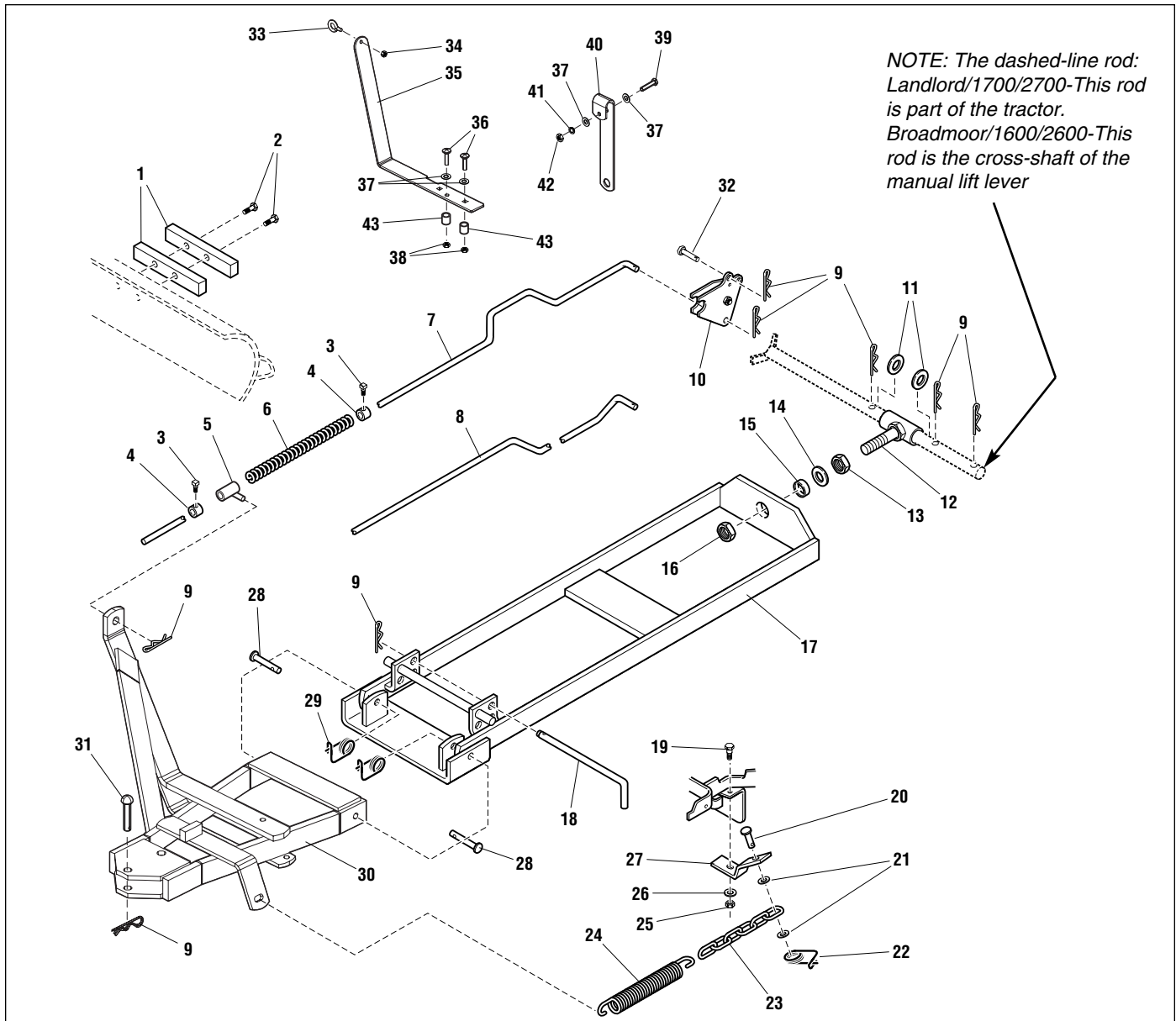

Figure 9. Push Bar, Hitch, & Lift Rod Components

Ref	Qty	Description	Ref	Qty	Description	Ref	Qty	Description
1	2	STOP, Bar	17	1	PUSH BAR ASSY, Rear	33	1	EYEBOLT, 1/4-20 x 1-1/2
2	2	SCREW, Taptite, 5/16-18 x 1	18	1	ROD, Latch	34	1	LOCKNUT, Nylock, 1/4-20
3	2	SETSCREWS, 5/16 x 1/2	19	1	CAPSCREW, 5/16-18x1	35	1	BRACKET, Control Rod
4	2	SET COLLAR	20	1	PIN, Hitch	36	2	CAPSCREW, 5/16-18 x 1-1/2
5	1	ROD GUIDE ASSY.	21	2	WASHERS, Plain 5/16	37	2	WASHER, 5/16
6	1	SPRING	22	1	SAFETY CLIP	38	2	LOCKNUT, Center, 5/16-18
7	1	ROD, Lift, Manual	23	1	CHAIN	39	1	CAPSCREW, 5/16-18 x 1-1/2
8	1	ROD, Lift, Electric/Hydraulic	24	1	SPRING	40	1	BRACKET, Control Rod
9	7	CLIP, Springs	25	1	NUT, Hex, 5/16-18	41	1	NUT, Hex, Full, 5/16
10	1	LIFT EXTENSION LEVER	26	1	LOCKWASHER, 5/16	42	1	LOCKWASHER, 5/16
11	2	WASHER	27	1	BRACKET, Anchor	43	2	SPACER
12	1	SUPPORT, Push Bar	28	2	CLEVIS PIN			
13	1	NUT, Hex, 5/8-11	29	2	SAFETY CLIP			
14	1	WASHER	30	1	PUSH BAR ASSY, Front			
15	1	SPACER	31	1	PIVOT PIN			
16	1	NUT, Hex, 5/8-11	32	1	CLEVIS PIN			

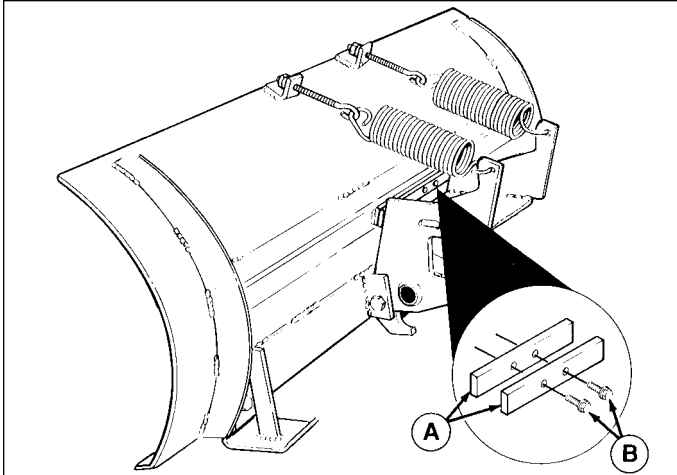

Figure 10. Bar Stop
A. Bar Stops
B. Taptite Screws, 5/16-18 x 1

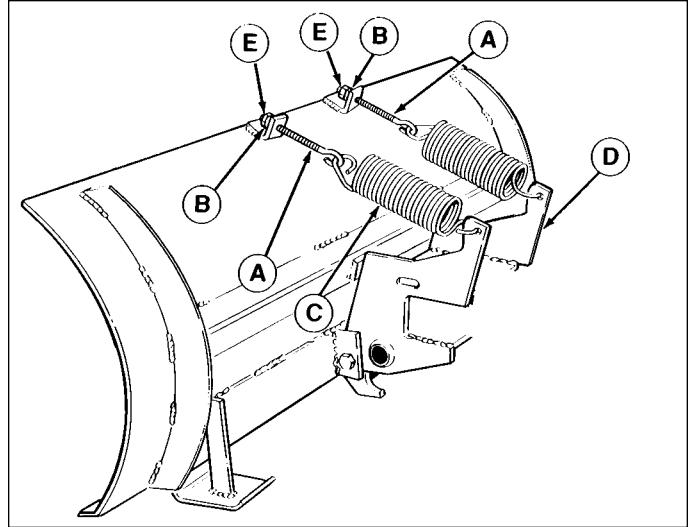

Figure 11. Tension Springs
A. Eyebolt
B. Nut, 5/16
C. Spring
D. Pivot Frame
E. Nut, 5/16

INITIAL SETUP & ASSEMBLY

NOTE: Some of the following setup procedures may already be completed.

Assemble Blade

1. Place the blade on a flat surface.
2. **Baron/Broadmoor/LT/1600/2600 Series:** See Figure 10. Install one bar stop (A) using the two 5/16-18 x 1 taptite screws (B). Do not install second bar stop.

Landlord/GT/1700/2700 Series: Do not install bar stops.

NOTE: See Figure 10 Generally, these models do not require the second bar stop to be used. However, if after adjusting the skid shoes all the way up, the blade is not able to make contact with the surface being plowed, bar stops must be added. Remove the dozer blade and install the second bar stop flush against the first one and remount blade assembly.

3. See Figure 11. Insert threaded end of eyebolt (A) through lug on blade, and screw on 5/16 nut (B) just far enough so that it is flush with the end of the eyebolt.
4. See Figure 11. Hook the springs (C) into the pivot frame (D). Using a pliers, stretch the springs to hook the opposite ends to the eyebolts (A).
5. See Figure 11. Tighten the nut (B) on each eyebolt enough to expose about 3/4" (19 mm) of thread.
6. See Figure 11. Holding the first nut (B) with a wrench, add a second nut (E) to each eyebolt, and tighten securely against the first nut to act as a jam nut.

Initial Setup & Assembly

Install Rear Push Bar Support

NOTE: Manual Lift Models-If your tractor is not already equipped with a Large Lift Lever kit, install it at this time. Follow the instructions supplied with the kit.

1. Assemble the push bar support (A, Figure 12) and hitch (F) using the hardware shown in Figure 12. Do not tighten the 5/8-11 nuts (B & E).

Install Hitch

CONNECT TO FRONT OF TRACTOR

1. Increase front tire pressure to 20 psi (138 kPa) to compensate for added weight of the hitch and blade. Be sure both tires have equal pressure.
2. From the front of tractor, slide the rear push bar assembly under the tractor so that the hitch bar is positioned at the front of the unit.
3. Turn the wheels fully left and lift the front hitch bar (B, Figure 13) up onto the tractor brackets (C). Make sure it is fully seated into the tractor brackets. Install the long hitch pin (D) through the bracket. Secure it with the safety clip (A).

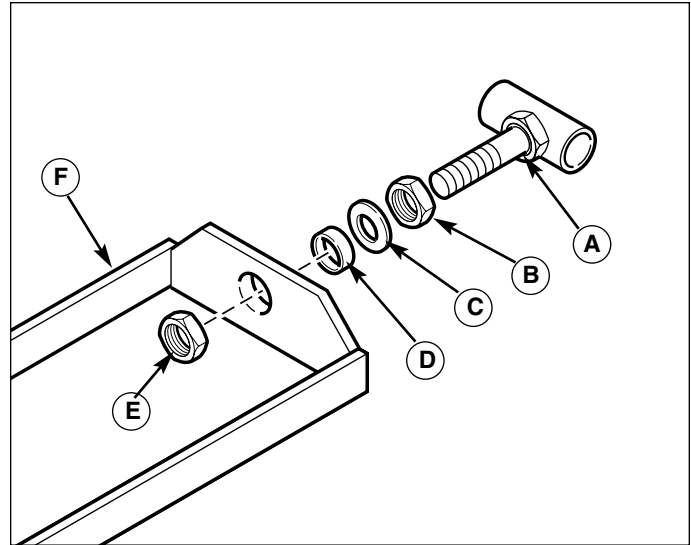

Figure 12. Attaching Push Bar Support to Hitch
A. Push Bar Support D. Spacer
B. Rear 5/8-11 Hex Nut E. 5/8-11 Hex Nut
C. Washer F. Hitch

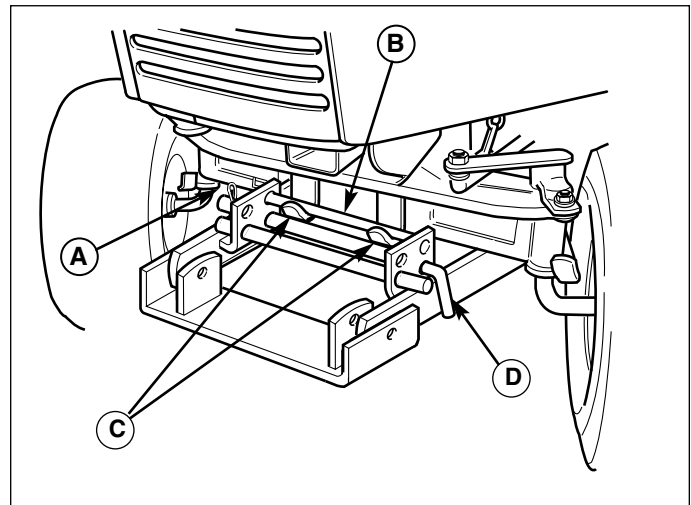
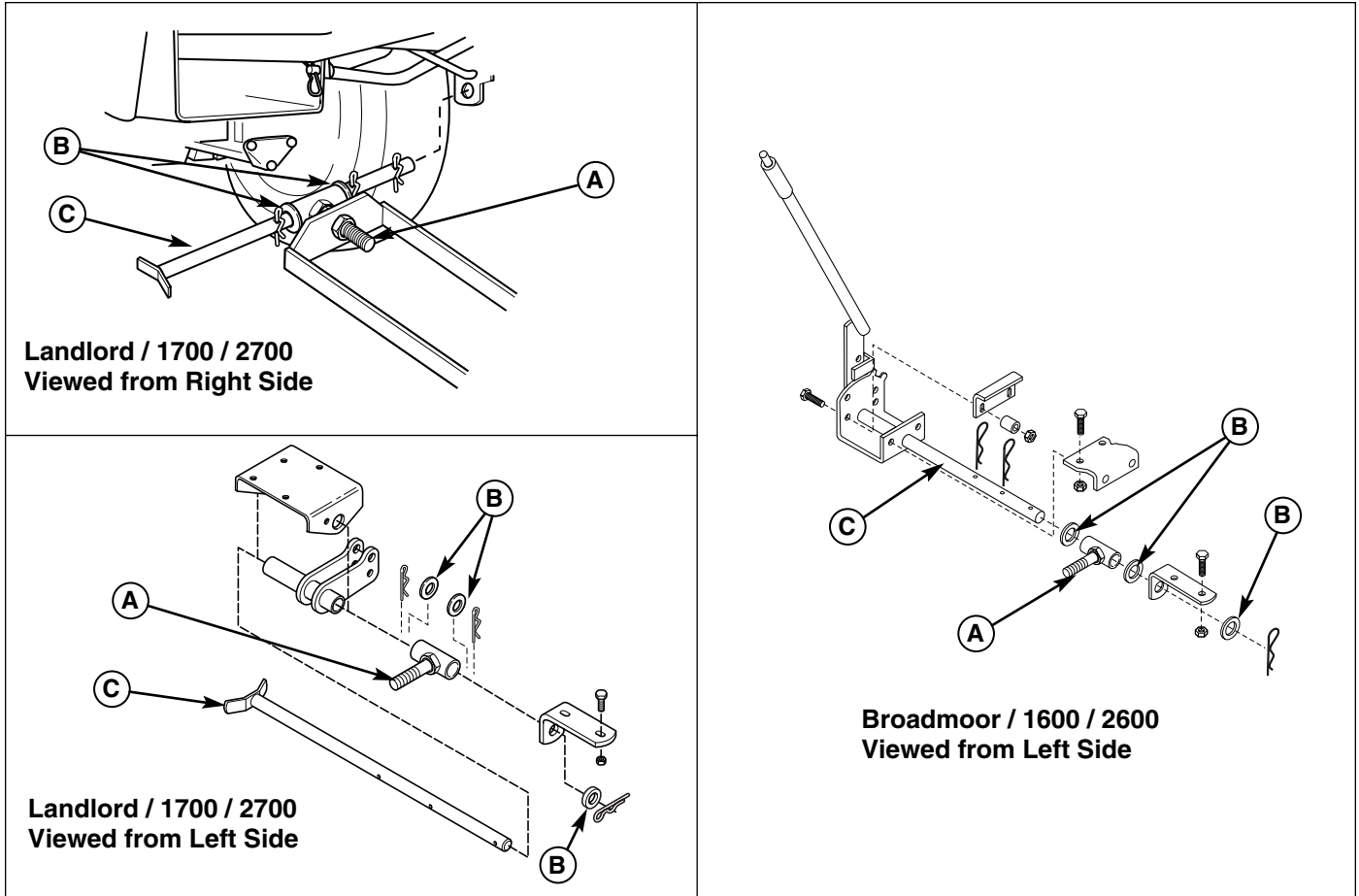

Figure 13. Installing Hitch to Front of Tractor
A. Safety Clip C. Tractor Brackets
B. Hitch Bar D. Hitch Pin



CONNECT HITCH TO REAR PUSH BAR

1. Slide the push bar support (A, Figure 14), and washers (B), onto the lift lever rod/lever (C), and secure to tractor frame with the spring clips.
2. Hand tighten the rear 5/8-11 nut (B, Figure 12) until it contacts against the back of the rear push bar. Tighten the front nut (E) tight against the spacer.

Install Pivot Hitch

1. Position the pivot hitch (A, Figure 15) under the front of the main hitch (B).
2. Position the front push bar assembly (A, Figure 15) between the side rail extensions on the front of the hitch (B). Align the mounting holes in the rear corners of the push bar with the mounting holes in the hitch. Secure push bar to the hitch using clevis pin (C) and safety clip (D).

Figure 14. Installing Hitch to Rear Bracket

A. Push Bar Support C. Lift Rod/Lever
B. Washers

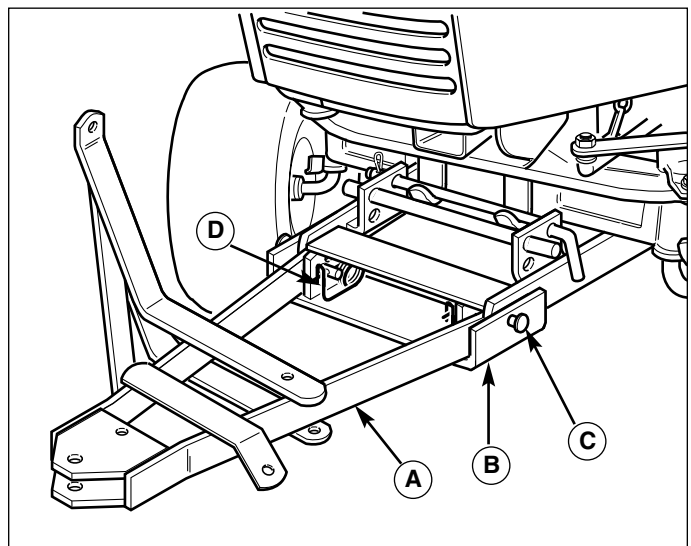

Figure 15. Install Push Bar Assembly

A. Push Bar Assembly C. Clevis Pins
B. Hitch D. Safety Clips

Initial Setup & Assembly

Install Spring Assist Bracket (Baron/Broadmoor/1600/2600 Models Only)

NOTE: Spring-assist bracket assembly (Figure 16) does not need to be installed on units with electric/hydraulic lift.

1. Install the spring-assist bracket (A, Figure 16) to tractor frame (bracket is mounted underneath frame). Secure with capscrew (from top), lockwasher, and nut. Place clevis pin (B) through bracket and install flat washer, chain (C), second flat washer, and safety clip (D).
2. Raise the push bar and attach the lift assist spring (B, Figure 17) to the assist spring bracket (A).
3. Connect the other end of the assist spring to the 6-link chain (C, Figure 16).

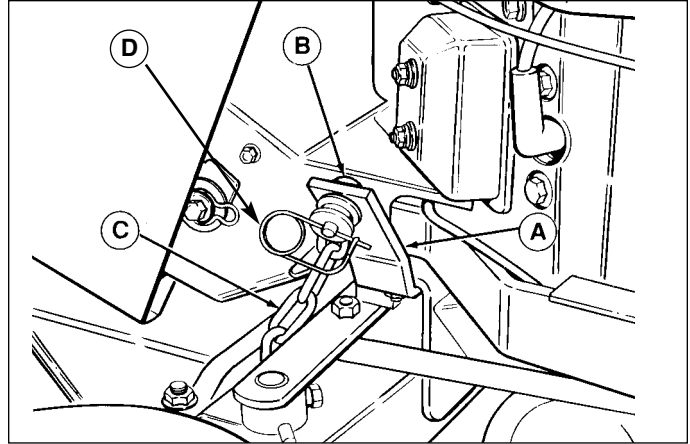

Figure 16. Spring Assist Bracket Assembly
A. Bracket
B. Clevis Pin
C. 6-Link Chain
D. Safety Clip

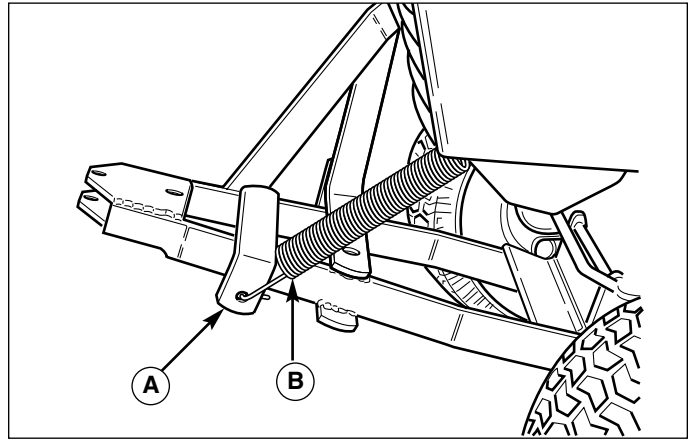

Figure 17. Lift Assist Spring
A. Assist Spring Bracket
B. Assist Spring

Install Dozer Blade

1. Insert the front of the push bar (A, Figure 18) into pivot frame (B) on rear of blade. Then install pivot pin (C) down thru front holes in blade and push bar. Secure the pivot pin (C) with a spring clip (D).

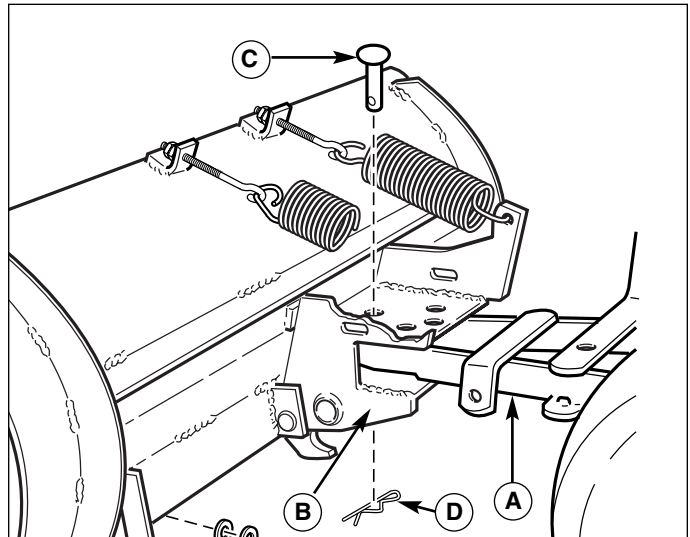

Figure 18. Dozer Blade Assembled and Installed
A. Push Bar
B. Pivot Frame
C. Pivot Pin
D. Spring Clip

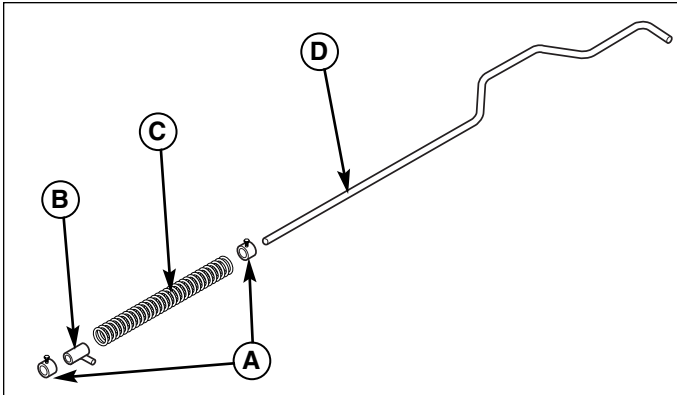

Figure 19. Lift Rod Assembly
A. Set Collars **C. Spring**
B. Rod Guide **D. Lift Rod**

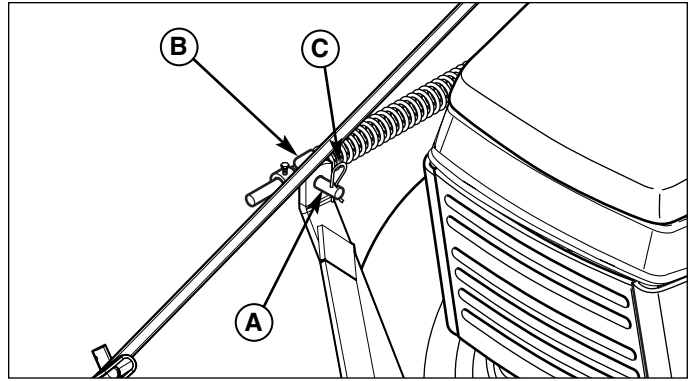

Figure 20. Lift Rod Assembly
A. Rod Guide
B. Push Bar Lift Arm
C. Spring Clip

Install Lift Rod

NOTE: Two lift rods are packaged with the Broadmoor/LT/1600/2600 & Landlord/GT/1700/2700 hitch assembly. Use the correct lift rod for manual or hydraulic lift as shown in Figure 9.

1. Assemble lift rod per Figure 19.
2. Insert prong of rod guide (A, Figure 20) through hole in upright of lift arm (B), and secure with spring clip (C).

Hydraulic/Electric Lift Units:

3. If your tractor is equipped with hydraulic/electric lift, install the lift lever extension assembly (A, Figure 21) to the lift arm (B) as shown. Secure with clevis pin (C) and spring clip (D) provided.
4. Install the 3/8 pin (E) removed from the mower and secure with spring clip (D).

Manual Lift Lever Units:

3. Connect rear of lift rod (A, Figure 22) to manual lift lever (B), and secure with spring clip (C).

Lift Rod Adjustment

Different types of terrain may require an adjustment to the lift rod assembly. For instructions on how to make this adjustment refer to the “**Lift Rod Adjustment**” procedure in the **ADJUSTMENTS** section of this manual.

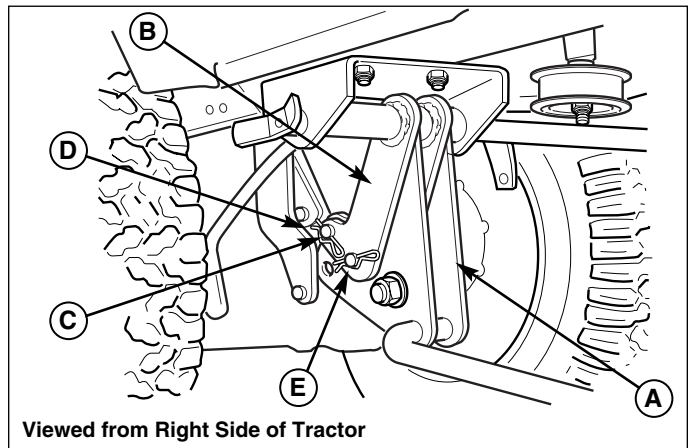

Figure 21. Hydraulic Lift Bracket
A. Lift Lever Ext. Assy **D. Spring Clip**
B. Lift Arm **E. 3/8 Mower Pin**
C. Clevis Pin

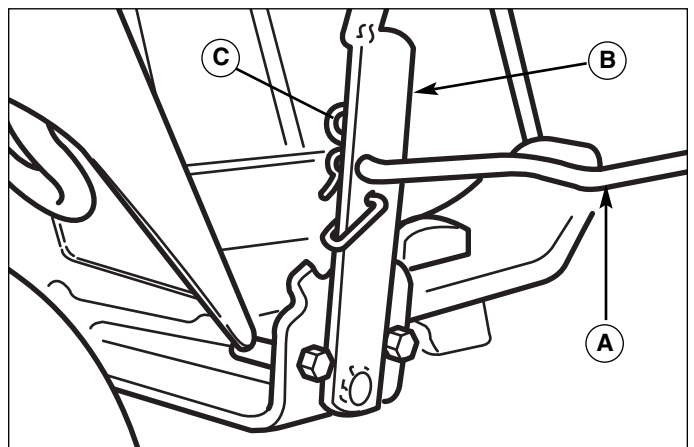

Figure 22. Installing Lift Rod to Manual Lift Lever
A. Lift Rod **C. Spring Clip**
B. Manual Lift Lever

Initial Setup & Assembly

Install Angling Control Rod

NOTE: If installing the dozer attachment on a unit equipped with a snowcab, replace the control rod support (A, Figure 23) with the hanging support (Ref. No. 40, Figure 9). Mount the hanging support to the front cab cross-bar.

1. Remove and discard the front two ratchet fasteners from the right foot rest pad. Drill out the holes using a 3/8" drill (Figure 23).
2. Set the angling control support (A, Figure 23) and spacers (E) on the foot rest pad. Insert two 5/16-18 x 1-1/2 capscrews (B) through the support spacers, footrest pad, and footrest. Secure using washers and nuts (C).

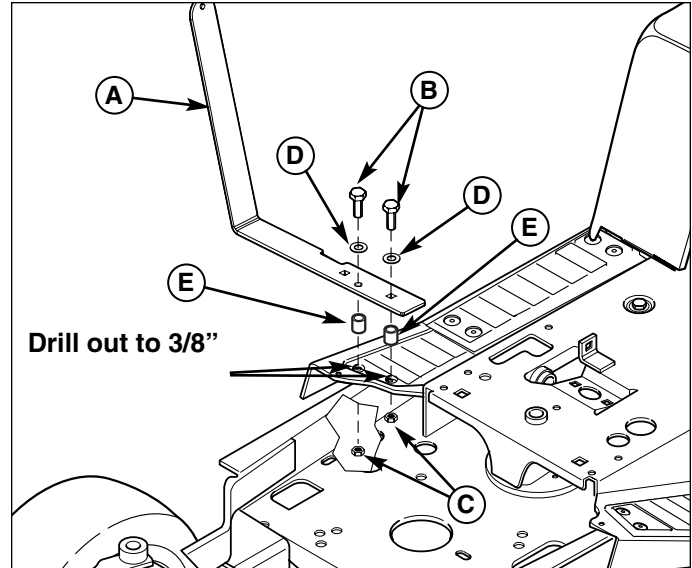

Figure 23. Control Rod Support

- A. Support
- B. 5/16-18 x 1-1/2 Capscrews
- C. 5/16 Centerlock Nuts
- D. 5/16 Plain Washers
- E. Spacers

3. Connect the lower angling rod (F, Figure 24) to the dozer release lever using a hair pin clip and washer (G).
4. Insert the upper control rod (C) through the eyelet (B), and secure the eyelet to the support using a 1/4-20 nylock nut (A).

NOTE: It may be necessary to leave the eyelet nut (A, Figure 24) loose to prevent binding.

5. Secure the upper rod (C) to the lower rod (F) using two 5/16-18 x 1-1/4 capscrews (D), washers (qty. 4), lockwashers, and nuts (E). *NOTE: Match offset to offset so the rods form a straight line.*

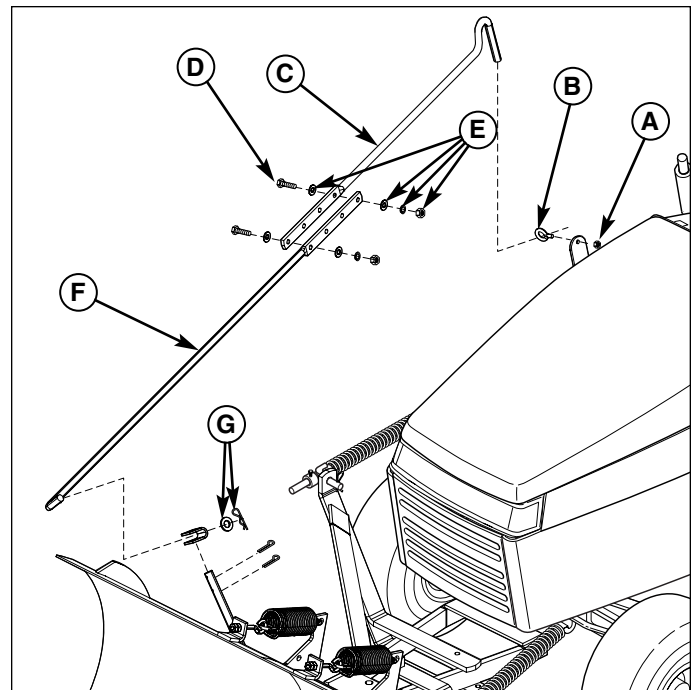

Figure 24. Assemble Control Rods

- A. 1/4-20 Nylock Nut
- B. Eyelet
- C. Upper Control Rod
- D. 5/16-18 x 1-1/4 Capscrew
- E. 5/16 Washers, Lockwashers, & Nuts
- F. Lower Control Rod
- G. Hair Pin Clip & Washer

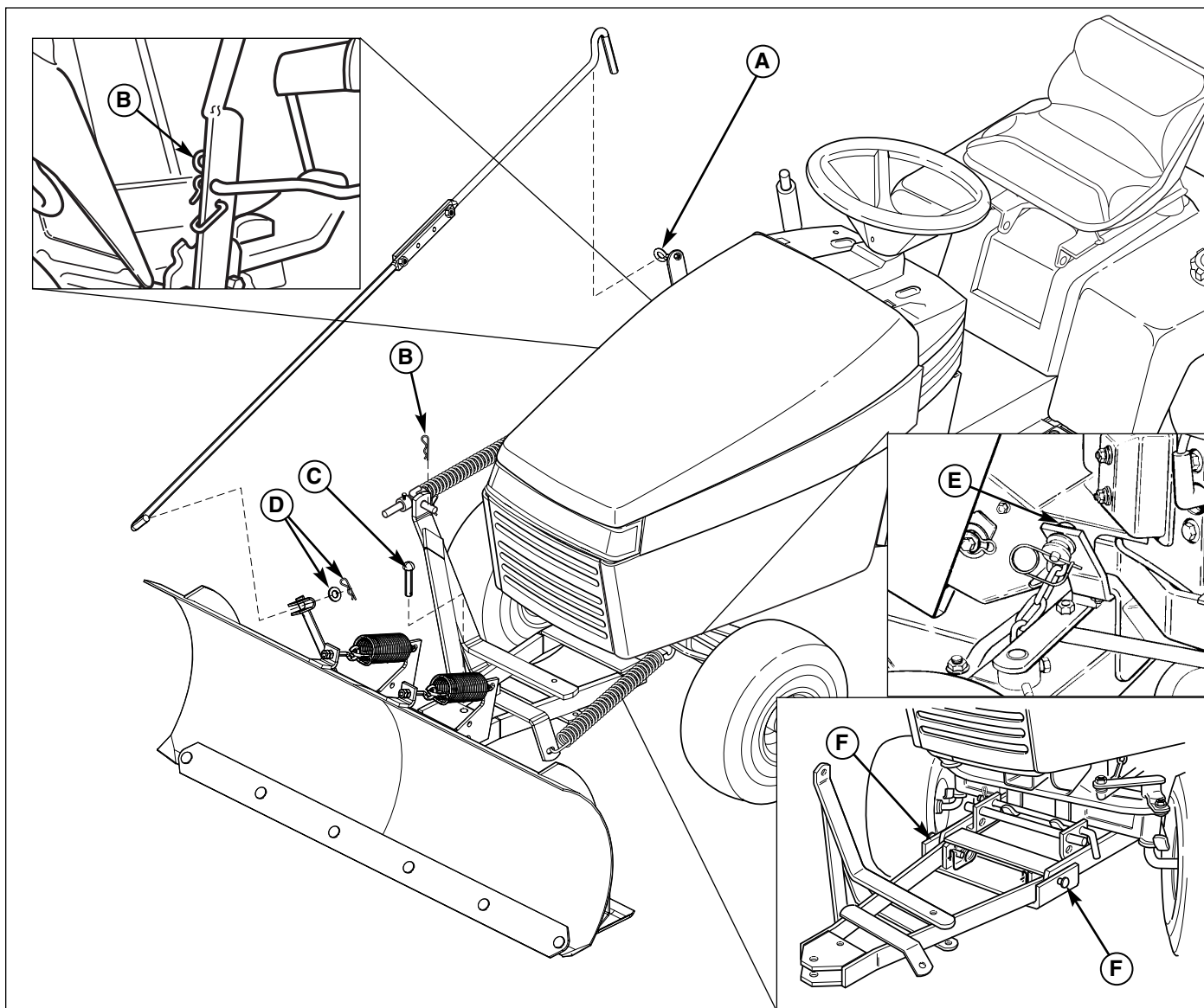

Figure 25. Dozer Removal

A. Support Arm
B. Hair Pin Clip

C. Pivot Pin
D. Hair Pin Clip & Washer

E. Clevis Pin
F. Clevis Pins

REMOVAL & INSTALLATION

Removing & Attaching Dozer Blade

1. Lower the blade. Put the lift lever in the middle notch (float position).
 2. Remove the hair pin clip and washer (D, Figure 25) securing the angling control rod to the clevis. Disconnect the angling control rod.
 3. Remove the angling control rod from the support arm (A).
 4. Remove the pivot pin (C) connecting the blade and pushbar. Remove the blade.
 5. Raise the push bar and remove pin (E) securing the chain to the chain bracket.
 6. Lower the lift and remove the clip (B) securing the lift rod to the push bar and lift rod.
 7. Remove the pins (F) securing the push bar to the tractor hitch.
 8. Reinstall all pins for storage.
- Install in reverse order of removal.

Removing & Attaching

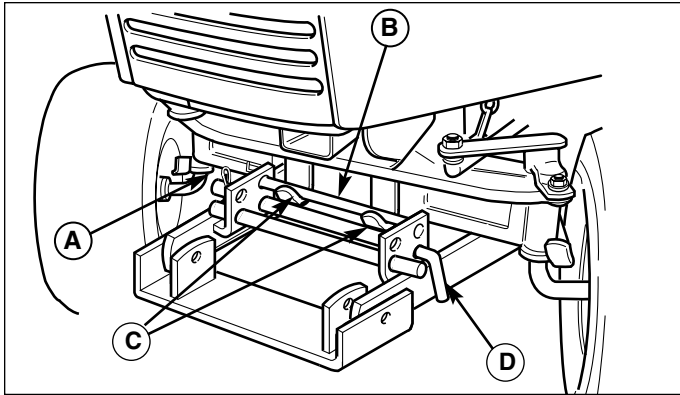

Figure 26. Installing Hitch to Front of Tractor
A. Safety Clip **C. Tractor Brackets**
B. Hitch Bar **D. Hitch Pin**

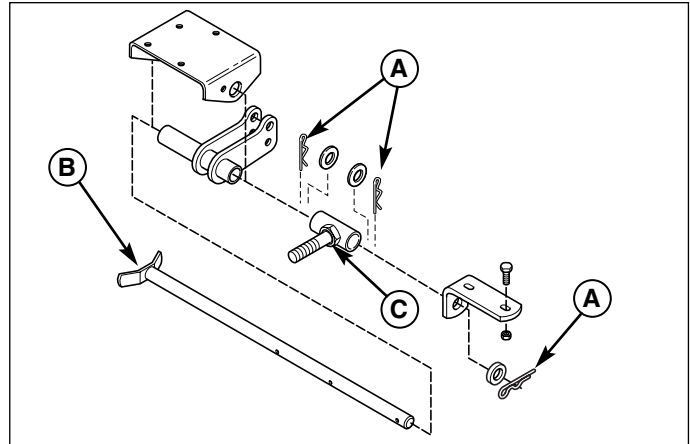

Figure 28. Hitch Removal - Landlord/1700/2700
A. Hair Pin Clips **C. Rear Hitch Bracket**
B. Lift Pivot Rod

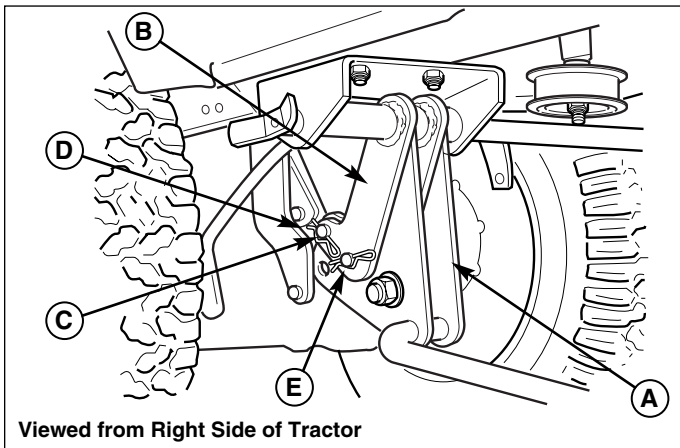

Figure 27. Hydraulic Lift Bracket
A. Lift Lever Ext. Assy **D. Spring Clip**
B. Lift Arm **E. 3/8 Mower Pin**
C. Clevis Pin

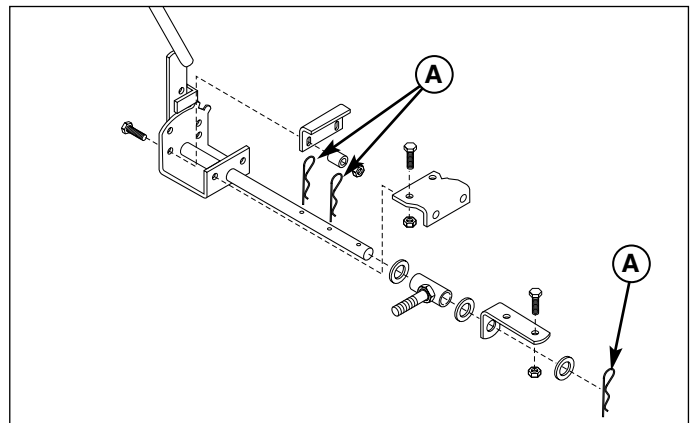

Figure 29. Hitch Removal - Baron/Broadmoor/1600/2600 Series
A. Hair Pin Clips

Removing & Attaching Hitch

1. Remove the safety clip (A, Figure 26) and remove the hitch pin (D).
2. Lift the hitch bar (B) off the tractor brackets (C).
3. Remove the spring clips (A, Figures 28 & 29) securing the rear hitch bracket (C) to the lift pivot rod (B).
4. **Hydraulic/Electric Lift Models:** Slide the lift pivot rod (B, Figure 28) out and remove the rear hitch bracket (C). Remove the lift lever extension.
5. **Manual Lift Models:** See Figure 30. Remove the capscrew from location (A). Depress the lift lever release button and rotate the lever forward until the lever latch clears the mounting bracket. Slide the lever and rod assembly out of the hitch bracket and mounting bracket.

Install in reverse order of removal.

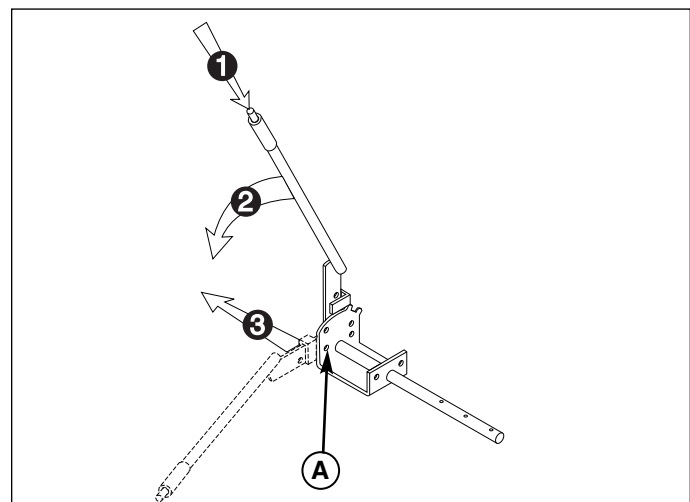

Figure 30. Lift Lever Removal
A. Capscrew Location (Remove)

Reinforcement Bracket Installation

INSTALL REINFORCEMENT BRACKET

NOTE: This kit applies to the Landlord / 1700 / 2700 Series hydraulic lift models only.

1. Loosen the four capscrews (A, Figure 32) securing the quadrant (B) to the footrest.
2. Insert the reinforcement bracket (B, Figure 31) between the quadrant (B, Figure 32) and foot rest. Align the hole in the bracket with the square hole (A, Figure 33) in the frame.
3. Secure the bracket (B, Figure 31) to the frame using a 5/16-18 x 3/4 carriage bolt (A), washer (C), lock-washer (D), and nut (E).
4. Tighten the quadrant hardware (A, Figure 32).

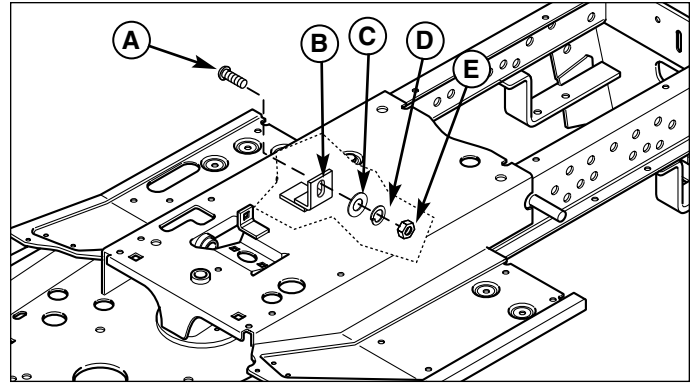

Figure 31. Support Bracket

A. Carriage Bolt, 5/16-18 x 3/4

B. Support Bracket

C. 5/16 Washer

D. 5/16 Locknut

E. 5.16-18 Nut

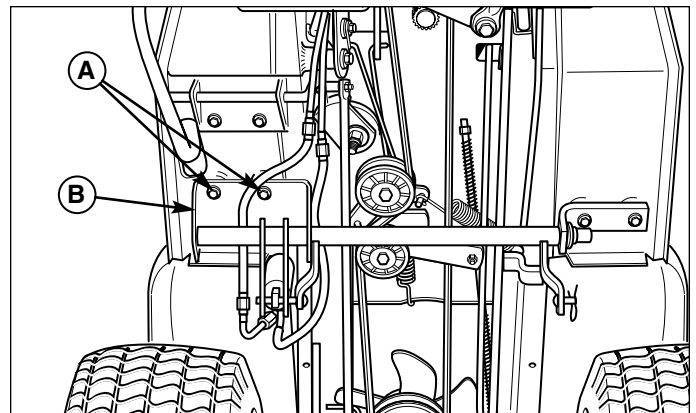

Figure 32. Lift Quadrant

A. Capscrews

B. Quadrant

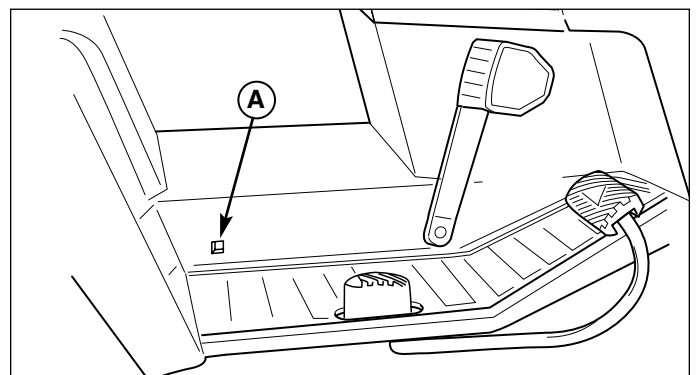
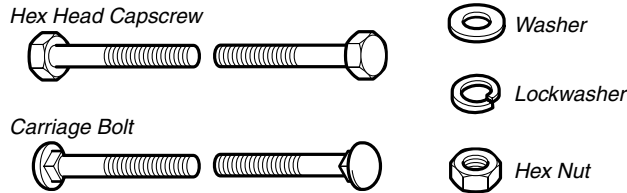

Figure 33. Right Side Foot Rest

A. Support Bracket Hole

Hardware Identification & Torque Specifications

Common Hardware Types



Standard Hardware Sizing

When a washer or nut is identified as **1/2"**, this is the *Nominal size*, meaning the *inside diameter* is 1/2 inch; if a second number is present it represent the *threads per inch*

When bolt or capscrew is identified as **1/2 - 16 x 2"**, this means the *Nominal size*, or *body diameter* is 1/2 inch; the second number represents the *threads per inch* (16 in this example, and the final number is the *body length* of the bolt or screw (in this example 2 inches long).

The guides and ruler furnished below are designed to help you select the appropriate hardware and tools.

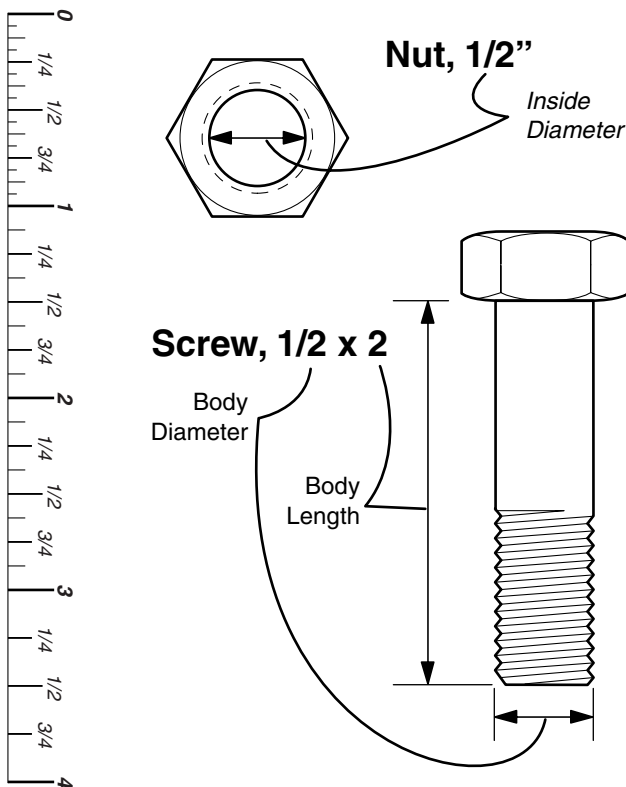

Torque Specification Chart

FOR STANDARD MACHINE HARDWARE (Tolerance $\pm 20\%$)

Hardware Grade	No Marks SAE Grade 2		SAE Grade 5		SAE Grade 8	
	in/lbs ft/lbs	Nm.	in/lbs ft/lbs	Nm.	in/lbs ft/lbs	Nm.
8-32	19	2.1	30	3.4	41	4.6
8-36	20	2.3	31	3.5	43	4.9
10-24	27	3.1	43	4.9	60	6.8
10-32	31	3.5	49	5.5	68	7.7
1/4-20	66	7.6	8	10.9	12	16.3
1/4-28	76	8.6	10	13.6	14	19.0
5/16-18	11	15.0	17	23.1	25	34.0
5/16-24	12	16.3	19	25.8	27	34.0
3/8-16	20	27.2	30	40.8	45	61.2
3/8-24	23	31.3	35	47.6	50	68.0
7/16-14	30	40.8	50	68.0	70	95.2
7/16-20	35	47.6	55	74.8	80	108.8
1/2-13	50	68.0	75	102.0	110	149.6
1/2-20	55	74.8	90	122.4	120	163.2
9/16-12	65	88.4	110	149.6	150	204.0
9/16-18	75	102.0	120	163.2	170	231.2
5/8-11	90	122.4	150	204.0	220	299.2
5/8-18	100	136	180	244.8	240	326.4
3/4-10	160	217.6	260	353.6	386	525.0
3/4-16	180	244.8	300	408.0	420	571.2
7/8-9	140	190.4	400	544.0	600	816.0
7/8-14	155	210.8	440	598.4	660	897.6
1-8	220	299.2	580	788.8	900	1,244.0
1-12	240	326.4	640	870.4	1,000	1,360.0

NOTES

- These torque values are to be used for all hardware excluding: locknuts, self-tapping screws, thread forming screws, sheet metal screws and socket head setscrews.
- Recommended seating torque values for locknuts:
 - for prevailing torque locknuts - use 65% of grade 5 torques.
 - for flange whizlock nuts and screws - use 135% of grade 5 torques.
- Unless otherwise noted on assembly drawings, all torque values must meet this specification.

Wrench & Fastener Size Guide

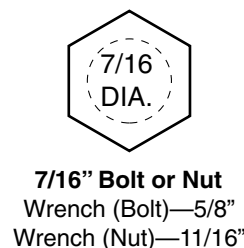
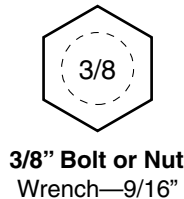
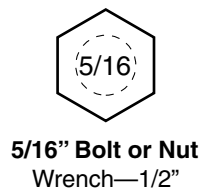
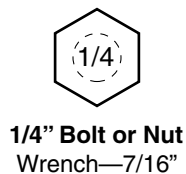



Simplicity Mfg. Inc.
500 N Spring Street / PO Box 997
Port Washington, WI 53074-0997 USA

© Copyright 2001 Simplicity Manufacturing, Inc.
All Rights Reserved. Printed in USA.