



# DYNAMIX HP-30 COAX

*128 Mbps*

*HPNA 3.0 over Coax Ethernet Bridge*



## User's Guide

## INTRODUCTION

**Dynamix HP-30 Coax**, HCNA (HomePNA3.0 over Coax) to Ethernet bridge connects any Ethernet device to a high speed access device or to a LAN for Internet access. This bridge brings you the newest Ethernet compatible technology that uses the coaxial cable as the network's physical wiring thereby eliminating the need to install new wiring. It is designed to operate on the coaxial TV cable installed in homes.

**Dynamix HP-30 Coax** enables You to set-up your Private Network at Home with your Existing Coaxial Cable. No additional Network wiring is necessary. You may just Find a Coax Connector in the wall, put the coaxial plug into the connector, you can then be ready to access the broadband Internet. No extra utility is needed. No setting, just link. Simply Plug & Play.

Via the RJ-45 Ethernet Ports, You can connect **Dynamix HP-30Coax** with the Ethernet -Interfaced Devices such as STB, Camera Server, PC, or Switch/Hub. The High speed of 128Mbps will bring you to enjoy the "video-on-demand" or "multimedia-on-demand" services.

This bridge allows you to connect PCs and Ethernet enabled devices, such as Switch, HUB and printers, to a Home Networking LAN by simply plugging into the existing coaxial F-Type connector.

With **Dynamix HP-30Coax** you can even quickly extend or flexibly change the existing LAN environment. No Re-wiring more.

### ***Features***

- Plug & Play
- Using existing coaxial TV cable to build a home network
- Shares high speed Internet access and streaming video
- 1 port 128Mbps connection compliant with HomePNA 3.0 over Coax (HCNA) standard
- 2 Standard 10/100BaseT Fast Ethernet ports for connecting to Ethernet or cable modem
- 10/100Mbps Auto Negotiation Support
- MDI/MDIX Auto Crossover Support
- QoS Priority Mapping Support

# HARDWARE INSTALLATION

## Parts Names and Functions

### LED Indicators on the Front Panel

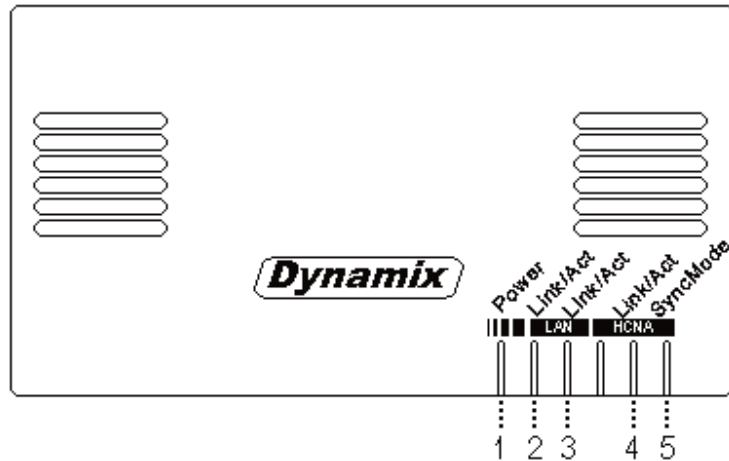

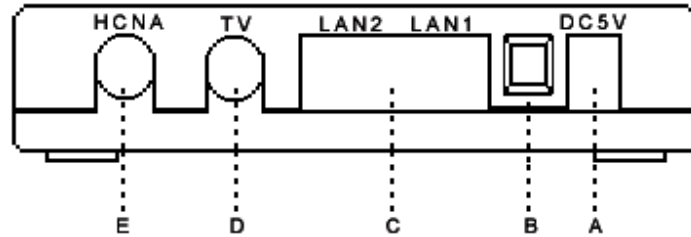

|   | LED                   | Status          |                         |                     |
|---|-----------------------|-----------------|-------------------------|---------------------|
|   |                       | Glowing         | Dimming                 | Flashing            |
| ① | <b>Power</b>          | Powered by DC5V | Not powered             | N/A                 |
| ② | <b>LAN Link /Act</b>  | LAN 1 Link      | Disconnect or Link fail | Receive or Transmit |
| ③ | <b>LAN Link /Act</b>  | LAN 2 Link      | Disconnect or Link fail | Receive or Transmit |
| ④ | <b>HCNA Link /Act</b> | HCNA Link       | Disconnect or Link fail | Receive or Transmit |
| ⑤ | <b>HCNA SyncMode</b>  | Sync. Mode      | Async. Mode             | N/A                 |

### Ports on the Rear Panel





|   | Port Name             | Type  | Functions   |
|---|-----------------------|-------|---|
| A | DC5V                  | DC    | Connect to the power adapter plug.  |
| B | DIP Switch            | DIP   | Reserved  |
| C | LAN1/LAN 2 (Ethernet) | RJ-45 | Connect to Ethernet port on FTTH or xDSL Modem or Switch for Internet Access. |
| D | TV                    | F     | Connect to TV   |
| E | HCNA                  | F     | Connect to HCNA devices   |

### Essential Hardwares

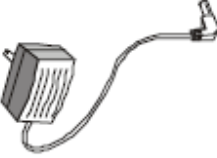
| Items Included  | Description                   | Purpose  |
|---|-------------------------------|--|
|  | HCNA to Ethernet Bridge       | Main Unit  |
|  | Coaxial Cable (F-Type/RG-59U) | Connects from HCNA port to coax F-Type connector on the wall outlet. |

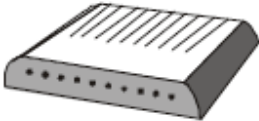
|   |                     |  |
|---|---------------------|--|
|  | CAT5 Ethernet cable | Connects from LAN port to Ethernet enabled devices as PC     |
|  | DC5V Power adapter  | Connects from power port of the main unit into a wall outlet |

| Additional Items (Not included)   | Description   |
|---|---|
|   | A well-installed WAN environment (FTTH or xDSL Modem) |
|  | A well-installed LAN environment                      |

### Hardware Connections

1. Select a convenient location for the bridge near the PC or Ethernet device to which it will be connected. The bridge should be kept away from excessive heat.
2. Using one coaxial cable to connect the **HCNA** port to F-Type connector on the wall. Using another coaxial cable to connect the other F-type **TV** port to TV set.
3. Connect the **LAN1/LAN2** port to your Ethernet equipped device.
4. Connect the power adapter to the **DC5V** port into a wall outlet.

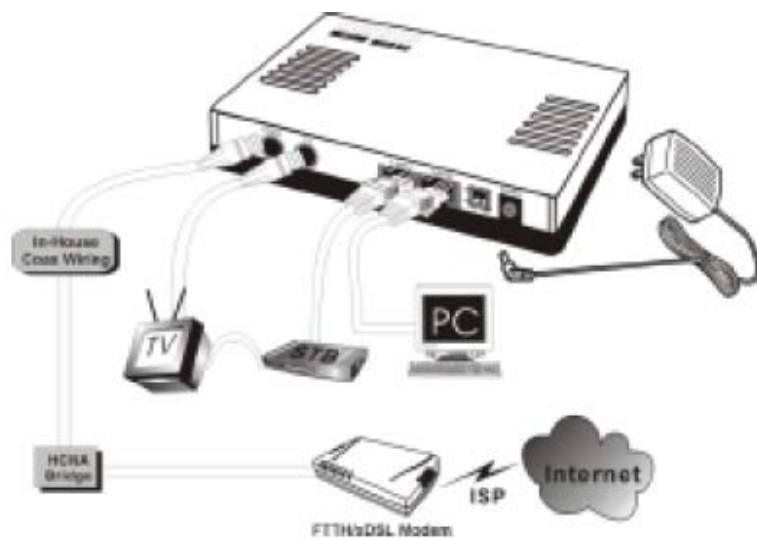

The figure above shows how to connect an xDSL modem to a home coaxial cable network. Follow the same steps to connect any Ethernet device such as a HUB or printer, to a coaxial cable network. Now you should have connected the **LAN** port, **HCNA** port and the **DC5V** port to the appropriate devices or lines. LED will be as:

POWER ON

LAN Link/Act ON

HCNA Link/Act ON

HCNA SyncMode ON

For more information on LEDs, see section

## "LED Indicators on the Front Panel"

### TROUBLESHOOTING

The bridge has been designed to be a reliable and easy to use connection device. Please refer to the list below to aid in troubleshooting.

#### **The Power (green) LED is off.**

- *Make sure the power adapter is properly plugged into a live electrical outlet.*

#### **The LAN(Ethernet) or HCNA Link/Act LED is off.**

- *Make sure the connection to these two ports is secure.*
- *The Ethernet or HCNA device to which you are connected should be powered on and properly configured*

#### **The HCNA SyncMode LED is off.**

- *The LED should be always ON after power on.*
- *The Ethernet or HCNA device to which you are connected should be powered on and properly configured.*

## **SPECIFICATIONS**

### **Standards**

- IEEE 802.3 10BaseT Ethernet compliant
- IEEE 802.3u 100BaseT Fast Ethernet compliant
- HomePNA 3.0 over Coax (HCNA) compliant

### **Data Rates**

- HCNA: 128 Mbps
- Ethernet: 10/100 Mbps

### **Distances**

- HCNA : 1200 meter maximum between the two farthest nodes on LAN
- Ethernet: 100 meter maximum

### **Power Consumption:**

- 5V DC IN, Less than 4 watt

### **Certifications**

- CE, FCC Part 15

### **LEDs**

- Power
- Ethernet Link/Activity
- HCNA Link/Activity; SyncMode

### **Connectors**

- Two F-Type connectors, one for connecting with HCNA device, and one for TV
- Two RJ-45 for 10/100M Ethernet

### **Cables**

- HCNA Network: F-Type RG-59U coaxial cable
- Fast Ethernet: CAT5 or better UTP