

EN

No film output on this page

THOMSON

U
S
E
R
M
A
N
U
A
L

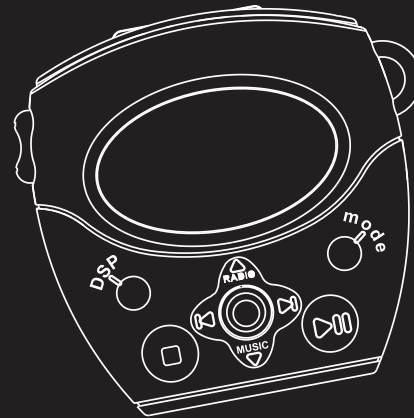

THOMSON multimedia
46/47 quai A. Le Gallo
92648 Boulogne Cedex
FRANCE
RCS nanterre
B 322 019 464
55522540
www.thomson-multimedia.com

PDP2225

Important Information

Warning

- Do not play your headset at a high volume. Hearing experts warn against extended high-volume play.
- If you experience a ringing in your ears, reduce volume or discontinue use.
- You should use extreme caution or temporarily discontinue use in potentially hazardous situations.

Even if your headset is an open-air type designed to let you hear outside sounds, don't turn up the volume so high that you are unable to hear what is around you.

Caution While Driving: Use of headphones while operating an automobile or moving vehicle is not recommended and is unlawful in some states and areas. Be careful and attentive on the road. Stop operation of the unit if you find it disruptive or distracting while driving.

Precautions for the Unit

- Do not use the unit immediately after transportation from a cold place to a warm place; condensation problem may result.
- Avoid shock to the unit especially during recording. Recorded data may be damaged.
- Do not store the unit near fire, places with high temperature or in direct sunlight.
- Do not operate or store unit in places with frequent static electricity or electrical noise (e.g. speaker, TV set).
- Clean the unit with a soft cloth or a damp chamois leather. Never use solvents.
- The unit must only be opened by qualified personnel.

Warning: Use of this product is for your personal use only. Copying CDs or downloading music files for sale or other business purposes is a violation of copyright law. It is also a violation of copyright law to download files without permission of the copyright owner.

Important Information

EN

Care of Memory Cards (Not Included)

- Do not touch the golden electrodes. Use a soft dry cloth to clean any dirt.
- Do not bend memory card.
- Do not operate or store memory card in places with frequent static electricity or electrical noise (e.g. speaker, TV set). Recorded data may be damaged.
- It is normal for memory card to get warm after being used for a long time.
- Always put it in storage case after removing from the unit.
- Do not store memory card near fire, places with high temperature/ humidity or in direct sunlight.
- We recommend that you make a copy of your recorded contents into another media (e.g. floppy disc, tape) as back-up.

Power supply

- Battery power: AAA (LR03) x 2.

Battery Precautions

- When storing the unit, be sure to remove the batteries because they may leak and damage the unit.
- Batteries may leak electrolyte if inserted incorrectly, if disposed of in fire, or if an attempt is made to charge a battery not intended to be recharged.
- Never mix new batteries with old ones. Do not mix battery types.
- Discard leaky batteries immediately. Leaking batteries may cause skin burns or other personal injury.
- Do not charge batteries which are not intended to be recharged.
- Dispose of batteries, according to federal, state and local regulations.

Wyrób importowany przez
Thomson multimedia Polska Sp. z o.o.
Oddzia Consumer Products Marketing & Sales.

The descriptions and characteristics given in this document are given as a general indication and not as a guarantee. In order to provide the highest quality product possible, we reserve the right to make any improvement or modification without prior notice. The English version serves as the final reference on all product and operational details should any discrepancies arise in other languages.

Important Safety Information

IMPORTANT NOTE: To reduce the risk of fire or shock hazard, do not expose this player to rain or moisture.

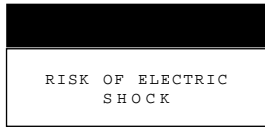

This symbol indicates "dangerous voltage" inside the product that presents a risk of electric shock or personal injury.

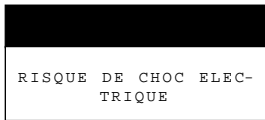

This symbol indicates important instructions accompanying the product.

TO REDUCE THE RISK OF ELECTRIC SHOCK, DO NOT REMOVE THE COVER (OR BACK). NO USER-SERVICEABLE PARTS ARE INSIDE. REFER SERVICING TO THE QUALIFIED SERVICE PERSONNEL.



Sound Pressure Control

Sound Pressure Control

Les articles de loi L44.5 et 44.6 du code de la santé publique, modifiés par l'article 2 de la loi du 28 Mai 1996 imposent une puissance acoustique maximale de 100 décibels. Le casque livré (code 55110130) et votre appareil respectent la législation en vigueur.

A pleine puissance, l'écoute prolongée du baladeur peut endommager l'oreille de l'utilisateur.

Table of Content

Important Information

Important Safety Information

Before You Begin 1

1. Unpacking the player and accessories 1
2. What's so special about this MP3 player 1
3. Insert batteries into the player . . . 2
4. Inserting a MultiMediaCard (optional) 2
5. Using Headphones 3
6. Connecting the Iyra Player to your Computer 3

General Controls 4

Radio controls 5

Digital music Operation 6

- Playback 6
- Stop Playback 6
- Skip / Search 6

Advanced Operation 7

- DSP 7
- Play Modes 7
- Programming Tracks 7
- Editing Program 7
- Key Lock 8
- File Download 8
- Adjust volume Level 8

Troubleshooting Tips 9

EN

Before you Begin

1. Unpack the player and accessories

When you unpack your new player, be sure you have removed all the accessories and information papers. The items shown below are packed with your player.

1. The Player
2. Batteries
3. Software CD
4. Digital X-Phone
5. Connection Cable
6. Neck Strap
7. Carry Case

2. What's so special about this MP3 player?

This player is meant to play MP3 files encoded on a memory card or recorded in the built-in flash memory. To do so, you need the use of a Windows computer with USB port, connection cable (included) and a music management software (MusicMatch Jukebox).

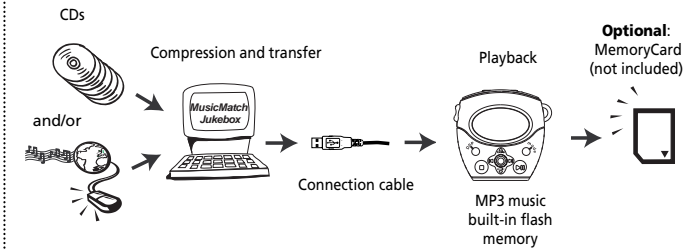

Compressed music internet sites
www.rca.com
www.musicmatch.com, www.emusic.com

1

Before You Begin

3. Insert batteries into the player

A. To insert batteries, lift open the battery compartment door.

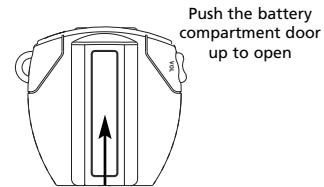

B. Insert 2 "AAA"(LR03) batteries with polarities corresponding to indications on the compartment. (Refer to "More information" for battery precautions.)

C. Close the door to the battery compartment

Note: Refer to the power level indicator on display for battery level. Replace with new batteries when the indicator is empty.

EN

4. Inserting a SD card / MultiMediaCard (Optional)

The player has built-in flash memory. To extend the playtime, you can use the optional Memory Card slot.

A. Insert a Memory Card into the card slot when the player is off as the diagram shows:

B. To remove card, push the Memory Card to eject.

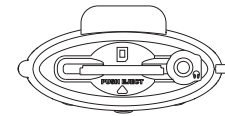

Caution: Do not remove Memory Card during playback or when power is on. It may stop unit from playing immediately.

2

Before You Begin

5. Using Headphones

Insert phone jack into **PHONES** on the side of player for listening.

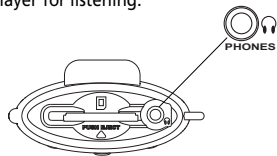

Note: Have a Blast- Just Not in Your Eardrums. Make sure you turn down the volume on the unit before you put on headphones. Increase the volume to the desired level only after headphones are in place.



6. Connecting the Lyra Player to your Computer

1. Lift the rubber cover on the player.
2. Insert the smaller end of the connection cable into the socket tightly.
3. Insert the opposite end of the connecting cable to the USB socket on the back of the computer.

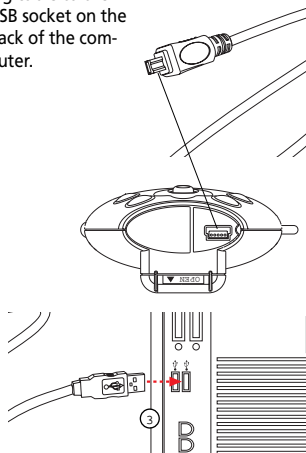

Note: Refer to the Software Instruction manual for procedures in setting up USB drivers and transferring files to the player.

General Controls

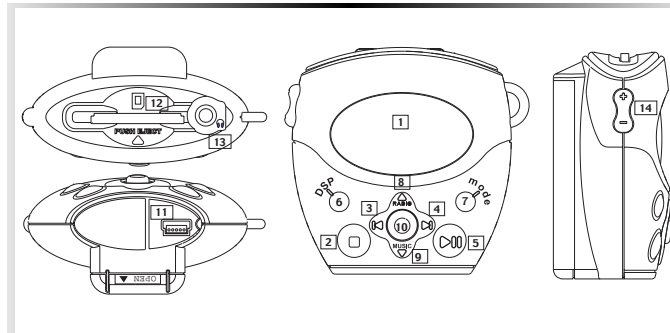

EN

1. **DISPLAY**
2. **STOP** - Stops playback and turn unit off .
3. **LAST** - Skips back to last track. Press and hold to search backward through the track.
4. **NEXT** - Skips to next track. Press and hold to search forward through the tracks.
5. **PLAY** - Turns unit on, start playback and pause, mute operation in Radio mode.
6. **DSP** - Selects among DSP modes. (Flat, Bass, Pop, Rock, Jazz, Tone)
7. **MODE** - Selects between repeat one, repeat all, random playback, random shuffle, program and program repeat all modes.
8. **RADIO** - Selects radio mode.
9. **MUSIC** - Selects Digital music playback mode.
10. **ENTER** - Presses to confirm selection.
11. **USB** - Connects USB cable.
12. **MEMORY CARD** - Slot for inserting Memory Card.
13. **PHONES** - Inserts headphones
14. **VOLUME** - Adjusts sound volume.

Radio Controls

Listening to the radio(FM only)

Manual search

1. Press **PLAY** to turn on the unit.
2. Push the **ENTER** knob upward to enter radio mode.
3. You may tune up or tune down the frequency by pushing the **ENTER** knob to the left/right.

Auto search / Preset a station

1. In radio mode, keep pushing the **ENTER** knob to the left/right for 2 seconds, the unit will start searching for a station.
2. The unit will stop searching when a station is found.
3. You may save the station by pressing **ENTER**, then push the **ENTER** knob to the left/right to select the location you want to store the station in (0-9).
4. Press **ENTER** to confirm. A preset station is stored.

Select a preset station

1. In radio mode, press **MODE** button.
2. You may recall your previously saved preset station (0-9)
3. Push the **ENTER** knob to the left/right to select your desired preset station.
4. Press **ENTER** to confirm selection.

5

Mono / Stereo selection

1. In radio mode, press DSP button to toggle between ST / Mono.

Adjust Volume Level

- Press + or - to adjust sound volume. Refer to the volume level on display for sound level.

Digital music Operation

Playback

1. In OFF mode, press **PLAY** to turn the unit on.
2. Select music by pushing the **ENTER** key downward, then the total number of tracks will show on display. Playback then starts automatically from the first track.
3. You can press **PLAY** button during playback to pause and press again to resume playback.
4. During playback, you can press **ENTER** to display complete song title and artist information.

Stop Playback

1. During playback, press **STOP** to stop playback (Stop mode) with total number of tracks will show on display.
2. Press **STOP** again to exit to the WELCOME screen. (The unit will turn itself off automatically after idle for about 1 minute.)

Skip / Search (Scan)

1. In stop mode, push **⏪** or **⏩** to select desired tracks.
2. Push **⏩** once to skip to next track. Push and hold for quick forward scan of playing track.
3. Push **⏪** once to return to previous track. Push and hold for quick backward scan of playing track.

EN

6

Troubleshooting Tips

The player does not turn on when **PLAY** button pressed.

- Batteries may be inserted incorrectly.
- Batteries may be empty.

Skipping tracks or bad sound quality?

- Repeat, random or program function may be activated.
- There may be strong magnetic fields (e.g. too close to TV) near the unit.
- Low Battery level. Replace with new ones.

Cannot perform playback?

- **LOCK** function may be activated.
- There may be no MP3 tracks in the card or internal memory.
- Memory Card may be damaged.

USB display does not appear when connected to computer.

- Check connection between your unit and the computer. (Refer to Software Instruction Manual)
- Check if USB drivers are properly installed (Refer to Software Instruction Manual)

The player does not respond to key operations?

- Turn the player off by removing the batteries. Reinsert the batteries properly and turn the player on again to resume normal operations.

Lyra Helpline

More help is available on www.thomson-lyra.com and phone numbers of the Lyra helpline per countries are listed below.

EN

HELPLINE THOMSON

Votre Contact THOMSON: 0 810 810 891, de le 16.10.2000
(pour la France, prix d'un appel local)

Ihr Kontakt zu THOMSON: 0180 1000 390, ab 16.10.2000.
(für Deutschland, Kosten zum Ortstarif)

You can contact THOMSON by dialling: 0845 601 3093, from 16 October 2000
(For Great-Britain, all calls will be charged at local rate)

Para contactar con THOMSON marque: 901 900 410, a partir del 16.10.2000
(las llamadas serán cargadas al precio de la tarifa local)

Il vostro contatto THOMSON: 8488 10 168, dal 16.10.2000
(tariffa chiamata urbana)

www.thomson-europe.com

Wyrób importowany
Przez Thomson Consumer
Electronics Poland