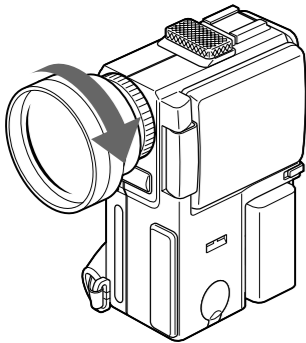
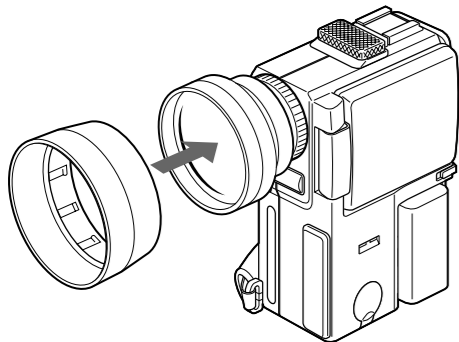

1**2****Português**

Antes de utilizar a sua objectiva, leia atentamente este manual e guarde-o para futuras consultas.

Notas acerca do uso

- Evite submeter a videocâmara a manuseamentos bruscos ou choques mecânicos, especialmente quando a objectiva estiver acoplada.
- Na utilização da objectiva de teleconversão em uma posição de grande angular, os cantos do écran podem ficar escuros. Neste caso, altere a magnificação do zoom para uma melhor posição.
- A imagem pode aparecer, às vezes, fora de foco em algumas videocâmaras com função de focagem automática. Ajuste o foco manualmente em tais casos.
- Evite manter a objectiva em locais muito húmidos por um longo período, para evitar mofo.
- Retire a objectiva de teleconversão quando do transporte.

Acoplagem da objectiva de teleconversão

A objectiva de Sony VCL-2030 S teleconversão foi projectada para a utilização com a videocâmara Sony cujo filtro tenha 30 mm de diâmetro.

- 1** Remova as tampas da frente e de trás da objectiva de teleconversão.
- 2** Acople a objectiva de teleconversão firmemente na objectiva da videocâmara. (veja ilustração **1**)

Utilize a viseira antiofuscamento acessório fornecido quando reflexões da luz solar possam incidir durante filmagens em exteriores. (veja ilustração **2**)

Limpeza da objectiva de teleconversão

Remova a poeira na superfície da lente com uma escova sopradora ou uma escova macia. Remova impressões digitais ou outras manchas com um pano macio levemente humedecido em solução de detergente suave.

Especificações

Potência da objectiva	2,0
Estrutura da objectiva	3 grupos, 3 elementos
Rosca de parafuso para videocâmara	M30,0 × 0,75
Dimensões	Diâmetro máximo: ø 50 mm Comprimento: 30,6 mm
Peso (excluindo tampas)	Aprox. 85 g
Acessórios fornecidos	Tampas de objectiva (2) (para a frente e a traseira da objectiva) Estojo de transporte (1) Manual de instruções (1) Viseira antiofuscamento (1)

Design e especificações sujeitos a alterações sem aviso prévio.



Esta marca indica que este produto é um acessório genuíno para equipamento de vídeo Sony. A Sony recomenda-lhe que, quando adquirir equipamento de vídeo Sony, adquira também acessórios com o logótipo “GENUINE VIDEO ACCESSORIES”.

Po

XxxBefore using this lens, please read this manual thoroughly and retain it for future reference.

Notes on use

- Avoid rough handling or mechanical shock to the video camera recorder, especially when the lens is attached.
- When using the tele-conversion lens at a wide-angle position, the corners of the screen may darken. In this case, change the zooming magnification to a better position.
- The image may sometimes appear out of focus on some video camera recorders with auto focus function. Adjust the focus manually in such cases.
- Avoid keeping the lens in a very humid place for a long period of time to prevent mold.
- Take the tele-conversion lens off when transporting.

Attaching the tele-conversion lens

The Sony VCL-2030 S tele-conversion lens is designed for use with the Sony video camera recorder whose filter is 30 mm in diameter.

- 1** Remove the caps at the front and back of the tele-conversion lens.
- 2** Attach the tele-conversion lens firmly to the lens of the video camera recorder. (see illustration **1**)

Use the supplied accessory flare-prevention hood when sunlight reflections might occur while shooting outdoors. (see illustration **2**)

Cleaning the tele-conversion lens

Brush off dust on the surface of the lens with a blower brush or soft brush. Wipe off fingerprints or other smears with a soft cloth slightly moistened with a mild detergent solution.

Specifications

Lens power	2.0
Lens structure	3 groups, 3 elements
Screw thread for video camera recorder	M30.0 × 0.75
Dimensions	Maximum diameter: ø50 mm (2 in.) Length: 30.6 mm (1 1/4 in.)
Mass (excluding the caps)	Approx 85 g (3 oz.)
Supplied accessories	Lens cap (1) (for the front and back of the lens) Carrying case (1) Operating instructions (1) Flare-prevention hood (1)

Design and specifications are subject to change without notice.



This mark indicates that this product is a genuine accessory for Sony video products. When purchasing Sony video products, Sony recommends that you purchase accessories with this “GENUINE VIDEO ACCESSORIES” mark.

Rv

XxxBefore using this lens, please read this manual thoroughly and retain it for future reference.

Notes on use

- Avoid rough handling or mechanical shock to the video camera recorder, especially when the lens is attached.
- When using the tele-conversion lens at a wide-angle position, the corners of the screen may darken. In this case, change the zooming magnification to a better position.
- The image may sometimes appear out of focus on some video camera recorders with auto focus function. Adjust the focus manually in such cases.
- Avoid keeping the lens in a very humid place for a long period of time to prevent mold.
- Take the tele-conversion lens off when transporting.

Attaching the tele-conversion lens

The Sony VCL-2030 S tele-conversion lens is designed for use with the Sony video camera recorder whose filter is 30 mm in diameter.

- 1** Remove the caps at the front and back of the tele-conversion lens.
- 2** Attach the tele-conversion lens firmly to the lens of the video camera recorder. (see illustration **1**)

Use the supplied accessory flare-prevention hood when sunlight reflections might occur while shooting outdoors. (see illustration **2**)

Cleaning the tele-conversion lens

Brush off dust on the surface of the lens with a blower brush or soft brush. Wipe off fingerprints or other smears with a soft cloth slightly moistened with a mild detergent solution.

Specifications

Lens power	2.0
Lens structure	3 groups, 3 elements
Screw thread for video camera recorder	M30.0 × 0.75
Dimensions	Maximum diameter: ø50 mm (2 in.) Length: 30.6 mm (1 1/4 in.)
Mass (excluding the caps)	Approx 85 g (3 oz.)
Supplied accessories	Lens cap (1) (for the front and back of the lens) Carrying case (1) Operating instructions (1) Flare-prevention hood (1)

Design and specifications are subject to change without notice.



This mark indicates that this product is a genuine accessory for Sony video products. When purchasing Sony video products, Sony recommends that you purchase accessories with this “GENUINE VIDEO ACCESSORIES” mark.

AAA

XxxBefore using this lens, please read this manual thoroughly and retain it for future reference.

Notes on use

- Avoid rough handling or mechanical shock to the video camera recorder, especially when the lens is attached.
- When using the tele-conversion lens at a wide-angle position, the corners of the screen may darken. In this case, change the zooming magnification to a better position.
- The image may sometimes appear out of focus on some video camera recorders with auto focus function. Adjust the focus manually in such cases.
- Avoid keeping the lens in a very humid place for a long period of time to prevent mold.
- Take the tele-conversion lens off when transporting.

Attaching the tele-conversion lens

The Sony VCL-2030 S tele-conversion lens is designed for use with the Sony video camera recorder whose filter is 30 mm in diameter.

- 1** Remove the caps at the front and back of the tele-conversion lens.
- 2** Attach the tele-conversion lens firmly to the lens of the video camera recorder. (see illustration **1**)

Use the supplied accessory flare-prevention hood when sunlight reflections might occur while shooting outdoors. (see illustration **2**)

Cleaning the tele-conversion lens

Brush off dust on the surface of the lens with a blower brush or soft brush. Wipe off fingerprints or other smears with a soft cloth slightly moistened with a mild detergent solution.

Specifications

Lens power	2.0
Lens structure	3 groups, 3 elements
Screw thread for video camera recorder	M30.0 × 0.75
Dimensions	Maximum diameter: ø50 mm (2 in.) Length: 30.6 mm (1 1/4 in.)
Mass (excluding the caps)	Approx 85 g (3 oz.)
Supplied accessories	Lens cap (1) (for the front and back of the lens) Carrying case (1) Operating instructions (1) Flare-prevention hood (1)

Design and specifications are subject to change without notice.



This mark indicates that this product is a genuine accessory for Sony video products. When purchasing Sony video products, Sony recommends that you purchase accessories with this “GENUINE VIDEO ACCESSORIES” mark.

CCC

XxxBefore using this lens, please read this manual thoroughly and retain it for future reference.

Notes on use

- Avoid rough handling or mechanical shock to the video camera recorder, especially when the lens is attached.
- When using the tele-conversion lens at a wide-angle position, the corners of the screen may darken. In this case, change the zooming magnification to a better position.
- The image may sometimes appear out of focus on some video camera recorders with auto focus function. Adjust the focus manually in such cases.
- Avoid keeping the lens in a very humid place for a long period of time to prevent mold.
- Take the tele-conversion lens off when transporting.

Attaching the tele-conversion lens

The Sony VCL-2030 S tele-conversion lens is designed for use with the Sony video camera recorder whose filter is 30 mm in diameter.

- 1** Remove the caps at the front and back of the tele-conversion lens.
- 2** Attach the tele-conversion lens firmly to the lens of the video camera recorder. (see illustration **1**)

Use the supplied accessory flare-prevention hood when sunlight reflections might occur while shooting outdoors. (see illustration **2**)

Cleaning the tele-conversion lens

Brush off dust on the surface of the lens with a blower brush or soft brush. Wipe off fingerprints or other smears with a soft cloth slightly moistened with a mild detergent solution.

Specifications

Lens power	2.0
Lens structure	3 groups, 3 elements
Screw thread for video camera recorder	M30.0 × 0.75
Dimensions	Maximum diameter: ø50 mm (2 in.) Length: 30.6 mm (1 1/4 in.)
Mass (excluding the caps)	Approx 85 g (3 oz.)
Supplied accessories	Lens cap (1) (for the front and back of the lens) Carrying case (1) Operating instructions (1) Flare-prevention hood (1)

Design and specifications are subject to change without notice.



This mark indicates that this product is a genuine accessory for Sony video products. When purchasing Sony video products, Sony recommends that you purchase accessories with this “GENUINE VIDEO ACCESSORIES” mark.

KKK

XxxBefore using this lens, please read this manual thoroughly and retain it for future reference.

Notes on use

- Avoid rough handling or mechanical shock to the video camera recorder, especially when the lens is attached.
- When using the tele-conversion lens at a wide-angle position, the corners of the screen may darken. In this case, change the zooming magnification to a better position.
- The image may sometimes appear out of focus on some video camera recorders with auto focus function. Adjust the focus manually in such cases.
- Avoid keeping the lens in a very humid place for a long period of time to prevent mold.
- Take the tele-conversion lens off when transporting.

Attaching the tele-conversion lens

The Sony VCL-2030 S tele-conversion lens is designed for use with the Sony video camera recorder whose filter is 30 mm in diameter.

- 1** Remove the caps at the front and back of the tele-conversion lens.
- 2** Attach the tele-conversion lens firmly to the lens of the video camera recorder. (see illustration **1**)

Use the supplied accessory flare-prevention hood when sunlight reflections might occur while shooting outdoors. (see illustration **2**)

Cleaning the tele-conversion lens

Brush off dust on the surface of the lens with a blower brush or soft brush. Wipe off fingerprints or other smears with a soft cloth slightly moistened with a mild detergent solution.

Specifications

Lens power	2.0
Lens structure	3 groups, 3 elements
Screw thread for video camera recorder	M30.0 × 0.75
Dimensions	Maximum diameter: ø50 mm (2 in.) Length: 30.6 mm (1 1/4 in.)
Mass (excluding the caps)	Approx 85 g (3 oz.)
Supplied accessories	Lens cap (1) (for the front and back of the lens) Carrying case (1) Operating instructions (1) Flare-prevention hood (1)

Design and specifications are subject to change without notice.



This mark indicates that this product is a genuine accessory for Sony video products. When purchasing Sony video products, Sony recommends that you purchase accessories with this “GENUINE VIDEO ACCESSORIES” mark.