

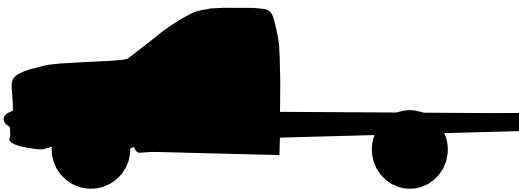

**DO NOT DESTROY: THIS MANUAL IS REQUIRED BY
LAW. KEEP UNTIL THE VEHICLE IS COMPLETED BY
THE FINAL STAGE MANUFACTURER.**

2006 SUPER DUTY F-SERIES INCOMPLETE VEHICLE MANUAL

**Incomplete Vehicle Types
For This Manual**



**Super Duty F-Series
Chassis Cab**

March, 2005
▽6C34-19A268-BA

U.S. & CANADIAN MOTOR VEHICLE SAFETY STANDARDS

(Application By Vehicle Type)

Standard Number	Title of Standard	Vehicle Type		Equipment (1)
		Truck	MPV	
101	Control Location, Identification and Illumination	X	X	
102	Transmission Shift Lever Sequence, Starter Interlock & Transmission Braking Effect	X	X	
103	Windshield Defrosting & Defogging Systems	X	X	
104	Windshield Wiping and Washing Systems	X	X	
105	Hydraulic and Electric Brake Systems	X	X	
106	Brake Hoses	X	X	X
108	Lamps, Reflective Devices & Associated Equipment	X	X	X
108.1	Headlamps (Canada only)	X	X	X
110	Tire Selection and Rims (U.S. only)	X	X	X
111	Rearview Mirrors	X	X	
113	Hood Latch Systems	X	X	
114	Theft Protection	X(2)	X(2)	
115	Vehicle Identification Number (Canada only)	X	X	
116	Hydraulic Brake Fluids	X	X	X
118	Power Operated Window, Partition, and Roof Panel Systems	X(2)	X(2)	
119 (9)	New Pneumatic Tires for Vehicles Other Than Passenger Cars			X
120	Tire Selection and Rims for Motor Vehicles Other Than Passenger Cars	X	X	X
124	Accelerator Control Systems	X	X	
201	Occupant Protection in Interior Impact	X(2)	X(2)	
202	Head Restraints	X(2)	X(2)	
203	Impact Protection for the Driver from the Steering Control System	X(2)	X(2)	
204	Steering Control Rearward Displacement	X(3)	X(3)	
205	Glazing Materials	X	X	X
206	Door Locks and Door Retention Components	X	X	
207	Seating System	X	X	
208	Occupant Crash Protection	X(5)(6)	X(5)(6)	X
209	Seat Belt Assemblies	X	X	X
210	Seat Belt Assembly Anchorages	X	X	
210.1	User-Ready Tether Anchorages for Restraint Systems (Canada only)	X	X	
210.2	Lower Universal Anchorage Systems for Restraint Systems and Booster Cushions (Canada only)	X	X	
212	Windshield Mounting	X(2)	X(2)	
213	Child Restraint Systems (U.S. only)	X	X	X
213.4	Built-In Child Restraint System & Built-In Booster Cushions (Canada only)	X	X	
214	Side Impact Protection	X(2)(7)	X(2)(7)	
219	Windshield Zone Intrusion	X(2)	X(2)	
225	Child Restraint Anchorage Systems (U.S. only)	X(8)	X(8)	
301	Fuel System Integrity	X(2)	X(2)	
302	Flammability of Interior Materials	X	X	
PART 565.4	Vehicle Identification Number (U.S. only)	X	X	
1106	Noise Emissions (Canada only)	X	X	

- (1) This column identifies Standards that have equipment/component requirements.
- (2) Applicable to vehicles with a GVWR of 4536 kg [10,000 lb] or less.
- (3) Applicable to vehicles with a GVWR of 4536 kg [10,000 lb] or less and an unloaded vehicle weight of 2495 kg [5,500 lb] or less.
- (4) Applicable to vehicles with a GVWR of 2722 kg [6,000 lb] or less.
- (5) Injury criteria applicable to vehicles with a GVWR of 3856 kg [8,500 lb] or less and an unloaded vehicle weight of 2495 kg [5,500 lb] or less.

- (6) Injury criteria is optional on Walk-in Van-Type Trucks, Motor Homes, vehicles manufactured for operation by persons with disabilities, etc.
- (7) Dynamic Performance Requirements apply to MPV, truck or a bus with a GVWR of 2722 kg [6,000 lb] or less.
- (8) Tether anchors and latch/ISO Fix lower anchors that are installed voluntarily or by regulation must comply with this Standard.
- (9) Canadian 119 requirements are found in the Motor Vehicle Tire Safety Standards.

INTRODUCTION

Information in this manual is furnished pursuant to United States and Canadian safety regulations or, in some cases where the information is not required by regulation, is furnished for the convenience of intermediate or final stage vehicle manufacturers. Incomplete vehicles manufactured for sale or importation into the U.S., are specially equipped for the United States. The descriptions and statements contained in the manual relate only to motor vehicle safety standards issued under the National Traffic and Motor Vehicle Safety Act of 1966 as amended.

An incomplete vehicle manufactured for sale or importation into Canada is specially equipped for Canada. This vehicle conforms to the applicable Canadian Motor Vehicle Safety Standards (CMVSS) on the date of manufacture printed on the cover of this manual. Requirements unique to vehicles for use in Canada are identified in the Statements of Conformity and the "Canadian Vehicles", page 25.

The Emission Certification Information section of this manual contains information regarding conformity to exhaust emission regulations of the United States, Canada, and the State of California and fuel economy regulations of the United States.

This manual should not be relied upon with respect to compliance with any regulation of the Federal Highway Administration or regulations issued pursuant to the Occupational Safety and Health Act (OSHA) or any other federal, state, or local regulations governing the performance or construction of motor vehicles (except for those requirements shown under the heading "Unleaded Gasoline Label," page 26; "Warranty and Maintenance," page 27; and "Emission Control Information Label," page 27). It is the responsibility of the final stage manufacturer to determine applicability and comply with any federal, state, or local requirements not detailed in this manual.

IMPORTANT:

UNITED STATES VEHICLES

Ford Motor Company has endeavored, whenever possible, to state the specific conditions under which an incomplete vehicle may be completed to conform to each applicable Federal Motor Vehicle Safety Standard. These specific statements are intended to aid subsequent stage manufacturers in avoiding instances of inadvertent noncompliance to particular standards.

Note that the final responsibility for the compliance of the completed vehicle rests with the final stage manufacturer who is required by law to certify, as prescribed by Section 567.5 of Title 49, Code of Federal Regulations, that the completed vehicle conforms to all applicable Federal Motor Vehicle Safety Standards and that all applicable federal, state and California emission/noise standards are conformed with.

Ford Motor Company does not make any representation as to the appropriateness of modifications for any particular application other than expressly stated herein. Intermediate and final stage manufacturers must exercise proper engineering judgment to determine if a modification is appropriate for their specific application.

IMPORTANT:

UNITED STATES AND CANADIAN VEHICLES

Alterations to an incomplete vehicle by someone other than Ford Motor Company, or damage in transit, may affect compliance statements that are furnished in this manual, or representations that are printed on the label that may be affixed to a vehicle.

TABLE OF CONTENTS

<u>U.S. & CANADIAN MOTOR VEHICLE SAFETY STANDARDS</u>	Inside Cover
<u>INTRODUCTION</u>	1
<u>DEFINITIONS</u>	3-4
<u>GENERAL INFORMATION</u>	5
Directions.....	5
<u>VEHICLE DESCRIPTION</u>	6
<u>COMPLETED VEHICLE TYPES</u>	7
<u>STATEMENTS OF CONFORMITY</u>	8-24
<u>CANADIAN VEHICLES</u>	
Vehicle Identification	25
Daytime Running Lamp (DRL).....	25
Canadian Radio Frequency Interference (RFI) Information.....	25
<u>EMISSION CERTIFICATION INFORMATION</u>	
Frontal Area and Weight Restrictions	26
High Altitude Requirements	26
Emission Control Hardware	26
Unleaded Gasoline Label	26
Exterior Noise	26
Tampering with Noise Controls	27
Warranty and Maintenance.....	27
Evaporative Emissions.....	27
Malfunction Indicator Light (MIL)	27
Power Take-Off Circuit	27
Ozone Depleting Substance (ODS).....	27
Emission Control Information Label.....	27
California Fuel Vapor Recovery	27
California Motor Vehicle Emission Control Label	28
Radio Frequency Interference (RFI)	28
<u>REFERENCE INFORMATION</u>	Back Cover

DEFINITIONS

The following definitions are from Title 49, Code of Federal Regulations (49CFR), Parts 567.3, 568.3 and 571.3 where noted. Canadian definitions are from Canadian Motor Vehicle Safety Regulations (CMVSR), Section 2(1), and are in italics. Ford Motor Company definitions are for the purpose of this manual only. Some terms are followed by an abbreviation that is used throughout this manual.

Ambulance – is a vehicle for emergency medical care which provides: A driver's compartment; a patient compartment to accommodate an Emergency Medical Technician (EMT), Paramedic, and two litter patients (one patient on the primary cot and secondary patient on folding litter located on the squad bench) so positioned that the primary patient can be given intensive life-support during transit; equipment and supplies for emergency care at the scene as well as during transport; two-way radio communication; and, when necessary, equipment for light rescue/extrication procedures. The Ambulance shall be designed and constructed to afford safety, comfort, and avoid aggravation of the patient's injury or illness. (From Federal Specification KKK-A-1822-E). Ford Motor Company also includes within its definition of ambulance any vehicle that is used for transporting life-support equipment, for rescue operations, or for non-emergency patient transfer if the engine of the vehicle is equipped with a "throttle kicker" device, which enables an operator to increase engine speed over normal idle speed when the vehicle is not moving. (Ford Motor Company)

B-Pillar – is the vehicle body structure located directly rearward of each front door. This structure will include the outer panel, all inner panels or reinforcements which support the door opening, the door latching system, and/or the roof structure. (Ford Motor Company)

Basic (Stripped) Chassis – an incomplete vehicle, without occupant compartment, that requires the addition of an occupant compartment and cargo-carrying, work performing, or load-bearing components to perform its intended function. (Ford Motor Company)

Bus – a motor vehicle with motive power, except a trailer, designed for carrying more than 10 persons. (49CFR571.3)

Bus (Canada) – *a vehicle having a designated seating capacity of more than 10, but does not include a trailer or a vehicle imported temporarily for special purposes. (autobus)*

Chassis Cab – an incomplete vehicle, with completed occupant compartment, that requires only the addition of cargo-carrying, work performing, or load-bearing components to perform its intended functions. (49CFR567.3)

Completed Vehicle – a vehicle that requires no further manufacturing operations to perform its intended function, other than the addition of readily attachable components, such as mirrors or tire and rim assemblies, or minor finishing operations such as painting. (49CFR568.3)

Critical Control Item – is a component or procedure which may affect compliance with a federal regulation or, which could directly affect the safe operation of the vehicle. The identifying symbol is an inverted delta (∇). (Ford Motor Company)

Cutaway Chassis – an incomplete vehicle that has the back of the cab cut out for the intended installation of a structure that permits access from the driver's area to the back of the completed vehicle. (Ford Motor Company)

Cutaway Chassis (Canada) – *an incomplete vehicle that has the back of the cab cut out for the intended installation of a structure that permits access from the driver's area to the back of the vehicle. (châssis tronqué)*

Designated Seating Position – any plan view location capable of accommodating a person at least as large as a 5th percentile adult female, if the overall seat configuration and design and vehicle design is such that the position is likely to be used as a seating position while the vehicle is in motion, except for auxiliary seating accommodations such as temporary or folding jump seats. Any bench or split-bench seat in passenger car, truck, or multipurpose passenger vehicle with a GVWR less than 4,536 kilograms (10,000 pounds), or having greater than 50 inches of hip room (measured in accordance with SAE Standard J1100(a)) shall have not less than three designated seating positions, unless the seat design or vehicle design is such that the center position cannot be used for seating. (49CFR571.3) (abbreviated by Ford Motor Company)

Designated Seating Position (Canada) – *any plan view position capable of accommodating a person at least as large as a 5th percentile adult female, as defined in section 100 of Schedule IV, where the overall seat configuration and design and the vehicle design are such that the position is likely to be used as a seating position while the vehicle is in motion, but does not include any plan view position of temporary or folding jump seats or other auxiliary seating accommodation. (place assise désignée)*

Final-Stage Manufacturer – a person who [company that (CMVSR)] performs such manufacturing operations on an incomplete vehicle that it becomes a completed vehicle. (49CFR568.3)

Gross Axle Weight Rating (GAWR) – the value specified by the vehicle manufacturer as the load-carrying capacity of a single axle system, as measured at the tire-ground interfaces. (49CFR571.3)

Gross Combination Weight Rating (GCWR) – the value specified by the manufacturer as the loaded weight of a combination vehicle. (49CFR571.3)

Gross Vehicle Weight Rating (GVWR) – the value specified by the manufacturer as the loaded weight of a single vehicle. (49CFR571.3)

H-Point – the mechanically hinged hip point of a manikin which simulates the actual pivot center of the human torso and thigh, described in SAE Recommended Practice J826, "Manikins For Use in Defining Vehicle Seating Accommodations," November 1962. (49CFR571.3)

H-point (Canada) – *the mechanically hinged hip point of a manikin that simulates the actual pivot centre of the human torso and thigh, described in SAE Standard J826 APR80, Devices for Use in Defining and Measuring Vehicle Seating Accommodation. (point H)*

Incomplete Vehicle – an assemblage consisting, as a minimum, of frame and chassis structure, power train, steering system, suspension system, and braking system, to the extent that those systems are to be part of the completed vehicle, that requires further manufacturing operations, other than the addition of readily attachable components such as mirrors or tire and rim assemblies, or minor finishing operations, such as painting, to become a completed vehicle. (49CFR568.3)

Incomplete Vehicle (Canada) – a vehicle (a) other than a vehicle imported temporarily for special purposes, that is capable of being driven and that consists, at a minimum, of a chassis structure, power train, steering system, suspension system and braking system in the state in which those systems are to be part of the completed vehicle, but requires further manufacturing operations to become a completed vehicle or (b) that is an incomplete trailer. (véhicule incomplet)

Incomplete Vehicle Manufacturer – a person [company that (CMVSR)] who manufactures an incomplete vehicle by assembling components none of which, taken separately, constitute an incomplete vehicle. (49CFR568.3)

Intermediate Manufacturer – a person [company (CMVSR)], other than the incomplete vehicle manufacturer or the final stage manufacturer, who [that (CMVSR)] performs manufacturing operations on an incomplete vehicle. (49CFR568.3)

Motor Home – a multi-purpose vehicle with motive power that is designed to provide temporary residential accommodations, as evidenced by the presence of at least four of the following facilities: Cooking; refrigeration or ice box; self-contained toilet; heating and/or air conditioning [system that can function independently of the vehicle engine (CMVSR)]; a potable water supply system including a faucet and a sink; and a separate 110-125 volt electrical power supply and/or an LP gas supply. (49CFR571.3)

Multifunction School Activity Bus (MFSAB) – a school bus whose purposes do not include transporting students to and from home or school bus stops. (49CFR571.3)

Multipurpose Passenger Vehicle (MPV) – a motor vehicle with motive power, except a low-speed vehicle or trailer, designed to carry 10 persons or less which is constructed either on a truck chassis or with special features for occasional off-road operation. (49CFR571.3)

Multipurpose Passenger Vehicle (MPV) (Canada) – a vehicle having a designated seating capacity of 10 or less that is constructed either on a truck-chassis or with special features for occasional off-road operation, but does not include an air cushion vehicle, an all-terrain vehicle, a golf cart, a low-speed vehicle, a passenger car, a three-wheeled vehicle, a truck or a vehicle imported temporarily for special purposes. (véhicule de tourisme à usages multiples)

Pickup Box Delete – a Chassis Cab incomplete vehicle created by ordering a Pickup Box Delete option on an otherwise completed vehicle. (Ford Motor Company)

School Bus – a bus that is sold, or introduced in interstate commerce, for purposes that include carrying students to and from school or related events, but does not include a bus designed and sold for operation as a common carrier in urban transportation. (49CFR571.3)

School Bus (Canada) – a bus designed or equipped primarily to carry students to and from school. (autobus scolaire)

Seating Reference Point – the unique design H-point, as defined in SAE J1100 (June 1984), which:

- Establishes the rearmost normal design driving or riding position of each designated seating position in a vehicle;
- Has X, Y, and Z coordinates established relative to the designed vehicle structure;
- Simulates the position of the pivot center of the human torso and thigh; and
- Is the reference point employed to position the two-dimensional drafting template described in SAE J826 (May 1987).

(abbreviated by Ford Motor Company)

Seating Reference Point (Canada) – the unique Design H-point, as defined in section 2.2.11.1 of SAE Recommended Practice J1100 (June 1993), that:

- establishes the rearmost normal design driving or riding position of each designated seating position, taking into account all modes of adjustment – horizontal, vertical and tilt – in a vehicle,
- has X, Y and Z coordinates, as defined in section 2.2.3 of SAE Recommended Practice J1100 (June 1993), established relative to the designed vehicle structure,
- simulates the position of the pivot centre of the human torso and thigh, and
- is the reference point employed to position the H-point template with the 95th percentile leg, as described in section 3.1 of SAE Standard J826 (June 1992), or, if that drafting template cannot be positioned, the reference point when the seat is in its rearmost adjustment position. (point de référence de position assise)

Second Unit Body (SUB) – consists of the body structure and/or all the cargo carrying, work performing, and/or load bearing components and/or equipment installed by a subsequent stage manufacturer on an incomplete vehicle, such that the incomplete vehicle becomes a completed vehicle. (Ford Motor Company)

Subsequent Stage Manufacturer – a term which means either intermediate or final stage manufacturers or both. (Ford Motor Company)

Trimmed Seat – a complete functional seat assembly including the seat pedestal, seat track, seat base frame, seat back, recliner mechanism, seat padding, all attaching hardware, and the final trim material (i.e., cloth, leather, or vinyl). (Ford Motor Company)

Truck – a motor vehicle with motive power, except a trailer, designed primarily for the transportation of property or special purpose equipment. (49CFR571.3)

Truck (Canada) – a vehicle designed primarily for the transportation of property or special-purpose equipment but does not include a competition vehicle, a crawler-mounted vehicle, a trailer, a work vehicle, a vehicle imported temporarily for special purposes or a vehicle designed for operation exclusively off-road. (camion).

Unloaded Vehicle Weight (UVW) – the weight of a vehicle with maximum capacity of all fluids necessary for operation of the vehicle, but without cargo, occupants, or accessories that are ordinarily removed from the vehicle when it is not in use. (49CFR571.3)

Unloaded Vehicle Weight (Canada) – the weight of a vehicle equipped with the containers for the fluids necessary for the operation of the vehicle filled to their maximum capacity, but without cargo or occupants. (poids du véhicule sans charge)

Untrimmed Seat – the structure including the seat pedestal, seat track, seat base frame, seat back, recliner mechanism, seat padding, and all attaching hardware required for a functional seat assembly without the final trim material (e.g., cloth, leather, or vinyl) and trim material attaching components. (Ford Motor Company)

Walk-In Van – a step entry city delivery van type vehicle that permits a person to enter the vehicle without stooping. This definition by Ford Motor Company is based on information appearing in 41 FR 54945, published December 16, 1976, and in 42 FR 34288, published July 5, 1977.

Walk-In Van (Canada) – a van type of truck in which a person having a height of 1700 mm can enter the occupant compartment in an upright position by a front door. (fourgon à accès en position debout)

GENERAL INFORMATION

Information in this section is provided pursuant to Title 49, Code of Federal Regulations, Part 568 – “Vehicles Manufactured in Two or More Stages”, and Section 6 of the Canadian Motor Vehicle Safety Regulations (CMVSR) – “Vehicles Manufactured in Stages.” Part 568 specifies that Final Stage Manufacturers must complete vehicles in compliance with all applicable Federal Motor Vehicle Safety Standards and affix a label to each incomplete vehicle that is completed in accordance with 49CFR567.5. Section 6.6 of the CMVSR provides labeling requirements for vehicles that are to be sold in Canada.

Each Chassis Cab (see definition on page 3) manufactured by Ford Motor Company has a label affixed to the driver-door lock pillar that identifies the following:

- The specific Federal Motor Vehicle Safety Standards to which the Chassis Cab conforms, as of the date of manufacture.
- The specific Federal Motor Vehicle Safety Standards to which the Chassis Cab will conform when completed as specified in this manual.
- The date of manufacture (month/year) of the Chassis Cab by Ford Motor Company.

DIRECTIONS

STATEMENTS OF CONFORMITY

The Statements of Conformity section, which begin on page 10 of this manual, lists the Federal Motor Vehicle Safety Standards in effect on the date of manufacture of this incomplete vehicle that are applicable to the type(s) of completed vehicles into which this incomplete vehicle may be manufactured. This date is shown on the label affixed to the cover of this manual. These statements, in most cases, apply to specific types of incomplete or completed vehicles and identify GVWR and UVW weight ranges.

The incomplete vehicle type is identified by the 5th, 6th, and 7th digits of the Vehicle Identification Number (VIN); see page 6. The completed vehicle types to which this incomplete vehicle may appropriately be completed is printed on the label, under the heading “May Be Completed As,” that is affixed to the cover of this document. The Completed Vehicle Types chart on page 7 identifies how various incomplete vehicles with an Optional Prep Packages or a Trim Code, may be completed.

Each statement of conformity is identified by a safety standard number located at the left margin. Because there may be multiple statements of conformity for each safety standard, use care to select the appropriate statement. Unique CMVSS requirements will be identified at the conclusion of the representations for a particular safety standard.

Compliance statements provided in this manual are of the three following types:

- Type I** • A statement that the vehicle, when completed, will conform to the standard if no alterations are made in identified components of the incomplete vehicle.
- Type II** • A statement of specific conditions of final manufacture under which the incomplete vehicle manufacturer specifies that the completed vehicle will conform to the standard.
- Type III** • A statement of conformity with the standard is not substantially affected by the design of the incomplete vehicle, and that the incomplete vehicle manufacturer makes no representation as to conformity with the standard.

IMPORTANT:

To rely on the compliance representations in this manual, the incomplete vehicles must be completed as one of the completed vehicle types designated on the label affixed to the cover of this manual, and must not exceed the specified GVWR, GAWRs, or the Unloaded Vehicle Weight limits when specified in this manual.

VEHICLE SPECIAL ORDER (VSO) VEHICLES

VSO vehicles can be identified by a six digit number with the letters VSO below the digits in the lower right corner of the Incomplete Vehicle Information label which is affixed to the driver-door lock pillar. See the sample label on page 6.

The Statements of Conformity section of this manual includes compliance representations for certain VSO vehicles. These vehicles are identified in the chart on page 7.

FORD TRUCK ASSISTANCE

Throughout this manual you will find references to information found in the *Ford Truck Body Builders Layout Book*. Additional Design Recommendations and specifications are also provided to assist subsequent stage manufacturers in completing chassis cab and incomplete vehicles. To obtain a free copy of this publication on CD-ROM or to receive an order form for additional CD-ROM's or books please visit our website at www.fleet.ford.com/truckbbas. Under Publications select Body Builders Order Forms. All dealer requests can be handled online. All other U.S. orders should be faxed to (734) 713-2971. Canadian orders should be faxed to (905) 670-0844.

The Ford Truck Body Builder Advisory Service may be consulted regarding information contained in this manual.

- Call (877) 840-4338
- Fax (313) 594-2633
- E-Mail bbasqa@ford.com or at the BBAS website – www.fleet.ford.com/truckbbas

Include your name, company and telephone number with all inquiries. If requesting written materials or a CD-ROM, include your mailing address.

VEHICLE DESCRIPTION

INCOMPLETE VEHICLE MANUAL COVER

The cover of this manual identifies the incomplete vehicle configuration for which compliance representations are contained in this manual. Also, a label is affixed to the cover which includes the Vehicle Identification Number (VIN) for the specific vehicle to which this manual belongs. The label identifies the following information which pertains only to the vehicle with the corresponding VIN.

- The GVWR
- The front and rear GAWRs
- Tire and wheel size
- Cold tire inflation pressure (kPa/PSI)
- Completed vehicle type(s) into which the incomplete vehicle may be manufactured
- Optional prep package when the vehicle is so equipped

INCOMPLETE VEHICLE INFORMATION LABEL

All F-Series Super Duty incomplete vehicles manufactured by Ford Motor Company will have an Incomplete Vehicle Information label affixed to the driver-door lock pillar. The sample labels, shown below, are typical of that provided.

The 5th, 6th, and 7th digits of the Vehicle Identification Number (VIN) will identify the incomplete vehicle type. These three digits are used in the Completed Vehicle Types chart on page 7.

California Air Resources Board (CARB), requires a Vehicle Identification Number (VIN) Label having a non-contact, bar-code, reading wand capability. The bar-code directly below the VIN on the Incomplete Vehicle Information label, when provided, will comply with this regulation. See page 28 for location and other requirements.

The Canadian Motor Vehicle Safety Act and Regulations require installation of an Incomplete Vehicle Information label with the National Safety mark on it on vehicles manufactured for sale in Canada. A label representative of those installed by Ford Motor Company assembly plants is shown below.

OPTIONAL PREP PACKAGES

Incomplete vehicles produced by Ford Motor Company, in some instances, are equipped with an optional prep package, such as Ambulance Prep. The completed vehicle type charts on page 7 will identify incomplete vehicles and the optional prep packages or trim codes that may be required by Ford Motor Company if final stage manufacturers wish to rely on the Statements of Conformity or, in some cases, preserve the Ford Motor Company new vehicle warranty.

If an incomplete vehicle is equipped with an optional prep package, both the Incomplete Vehicle Information label affixed to the vehicle and the label on the front of this manual will identify the prep package.

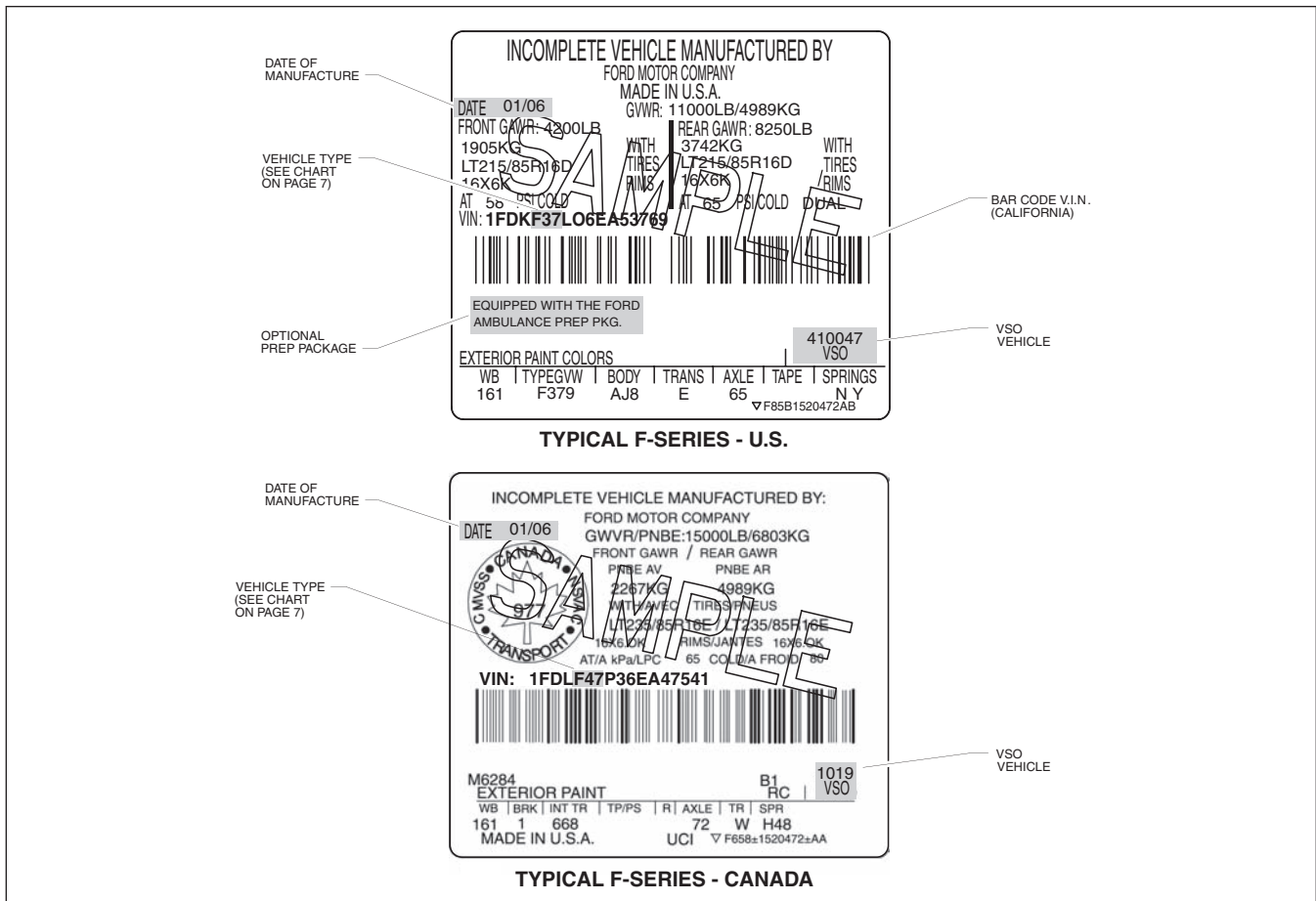

INCOMPLETE VEHICLE INFORMATION LABEL

COMPLETED VEHICLE TYPES

5TH, 6TH, 7TH VIN DIGIT	INCOMPLETE VEHICLES	COMPLETED VEHICLES	
		TRUCK	MPV
SUPER DUTY F-SERIES			
F20, F30, F34	F-250/350 Regular Cab 4X2 (SRW)*	X	X
F21, F31, F35	F-250/350 Regular Cab 4X4 (SRW)	X	X
F32, F36, F46, F56	F-350/450/550 Regular Cab 4X2 (DRW)**	X	X
F33, F37, F47, F57	F-350/450/550 Regular Cab 4X4 (DRW)	X	X
X20, X30, X34	F-250/350 Super Cab 4X2 (SRW)	X	X
X21, X31, X35	F-250/350 Super Cab 4X4 (SRW)	X	X
X32, X36, X46, X56	F-350/450/550 Super Cab 4X2 (DRW)	X	X
X33, X37, X47, X57	F-350/450/550 Super Cab 4X4 (DRW)	X	X
W20, W30, W34	F-250/350 Crew Cab 4X2 (SRW)	X	X
W21, W31, W35	F-250/350 Crew Cab 4X4 (SRW)	X	X
W32, W36, W46, W56	F-350/450/550 Crew Cab 4X2 (DRW)	X	X
W33, W37, W47, W57	F-350/450/550 Crew Cab 4X4 (DRW)	X	X

IMPORTANT:

Ford Motor Company makes no representation that the completed vehicle types listed above are the only vehicle types appropriate for the incomplete vehicles listed. However, if a unit is completed as a vehicle type other than as listed above, the Statements of Conformity may not be applicable.

* SRW – Single Rear Wheels

** DRW – Dual Rear Wheels

STATEMENTS OF CONFORMITY

The following Statements of Conformity apply to vehicles that are produced for sale or importation into the United States or Canada. The term "Incomplete Vehicle Types" in these statements refers to the type of the vehicle illustrated on this manual's cover and listed in the chart on page 7.

The number preceding each Statement of Conformity refers to the number designation for a Part or a Section of Part 571 of the Federal Motor Vehicle Safety Standard.

The statements provided for each safety standard number are appropriate compliance representations for each Canadian safety standard number if this incomplete vehicle, identified by the VIN on the front of the document, was manufactured by Ford Motor Company for sale or use in Canada, except as may be noted at the conclusion of each safety standard number.

PART

565.4 The statement below is applicable to all incomplete vehicle types except the Basic (Stripped Chassis):

This vehicle, when completed, will conform to Part 565.4, Vehicle Identification Number, if the vehicle identification number mounted on the top of the instrument panel is not removed, altered, or modified and no actions are taken by the subsequent stage manufacturer that would obstruct the readability of the Vehicle Identification Number mounted on the top of the instrument panel.

101 The statements below are applicable to the Chassis Cab:

This vehicle, when completed, will conform to Standard 101, Controls and Displays if:

- The controls, displays, and their identifications supplied by Ford Motor Company are not removed, relocated, altered, or modified.
- The components, wiring, and power supply installed by Ford Motor Company to illuminate any control, display, or their identification are not removed or altered so as to affect lighting performance.
- Components added to the vehicle do not obstruct the driver's ability to operate or visually locate the controls, displays, and their identifications.
- The driver-seat is not replaced, relocated, or modified other than for the addition of seat trim.

Any controls, displays, and illumination added to this vehicle must conform to the requirements of this Standard.

102 The statements below are applicable to the Chassis Cab:

This vehicle, when completed, will conform to Standard 102, Transmission Shift Lever Sequence, Starter Interlock, and Transmission Braking Effect, if no alterations or adjustments are made to:

- Automatic Transmission – the transmission, shift cable, transmission outer shift lever, shift cable bracket, vacuum tubes, vacuum pump system, brake-shift interlock system, the starter interlock system, and wiring circuit from the interlock switch to the power source.
- Manual and Automatic Transmission – the clutch-ignition interlock system (if equipped), transmission shift decal, knob, or transmission indicator dial identification.

If an auxiliary transmission is added to this vehicle, it must conform to the requirements of this Standard.

103 The statement below is applicable to the Chassis Cab:

This vehicle, when completed, will conform to Standard 103, Windshield Defrosting and Defogging Systems, if no alterations or adjustments are made to heater and blower assemblies, ducting, operating controls, electrical circuit from the blower assembly to the power source, windshield, coolant hoses from the radiator or engine to the heater, and if no obstructions are added that restrict or otherwise redirect the air flow from the defroster outlets to the windshield.

104 The statement below is applicable to the Chassis Cab:

This vehicle when completed, will conform to Standard 104, Windshield Wiping and Washing Systems, if no alterations are made to the windshield, the windshield wiping and washing system, including the electrical circuit from the windshield wiping and washing motors to the power source, and if no obstructions are added that restrict or otherwise redirect fluid flow from the washer nozzles to the windshield.

105 INFORMATION

Incomplete vehicle weight and dimensional information required for center of gravity calculations are available in the *Ford Source Book*. See your local Ford Dealer and refer to appropriate model year and specific vehicle for required information.

Abbreviation definitions and a vehicle diagram to assist with the equations for the Standard 105 segment are shown on page 10.

105 The statements below are applicable to the Chassis Cab:

This vehicle, when completed, will conform to Standard 105, Hydraulic and Electric Brake Systems, if:

- No alterations, modifications, or replacements are made to the following:
 - Service or parking brake system
 - Antilock brake system
 - Vacuum system
 - Wheels and tires
 - Brake system indicator lamp and wiring
 - Brake system reservoir labeling
 - Suspension ride height or spring rate
 - Hydro-boost system
 - Power steering pump and lines if used with Hydro-boost
 - Engine belt drive system
- No additional sound deadener or rust proofing material, that may be applied to the vehicle, can interfere with proper parking brake cable function.
- No part of add on equipment, i.e. toolboxes, flat bed attaching brackets, etc., can interfere with the movement of parking brake cables or air flow to rear brake assembly.
- Any removal of a Ford body or chassis component is accompanied by the addition of equal weight.
- Chassis Cab vehicles with a GVWR of 4536 kg [10,000 lb] or less do not exceed the Maximum Unloaded Vehicle Weight value in Table F, page 11.
- The applicable GAWRs and GVWR weights are not exceeded.
- The completed vehicle must have a vertical center of gravity (Equation A) of 48.00 inches or less when measured from the ground.
- The front axle curb weight of the completed vehicle (incomplete vehicle weight + min SUB weight, Table G, page 12) may be reduced by no more than 10% for SRW or 25% for DRW vehicles, using the front axle ground reaction as manufactured by Ford Motor Company.
- The rear axle curb weight of the completed vehicle (incomplete vehicle weight + min SUB weight, Table G, page 12) must be the same or greater than the rear axle ground reaction as manufactured by Ford Motor Company.

REFERENCE: Equation B can be used to determine the completed vehicle's horizontal center of gravity (CG_h). Abbreviation definitions and a vehicle diagram are provided to assist with the equation on page 10.

EQUATION A

$$CG_v = \frac{CG_{vb}W_b + CG_{vc}(W_c + W_l) + (CG_{vp}) \times P}{GVWR}$$

EQUATION B

$$CG_h = \frac{(W_{rb} + W_{rc} + \left(\frac{P \times CG_{hp}}{WB}\right) + W_{rl}) \times WB}{GVWR}$$

TABLE A

CG_{hl} = Horizontal distance from front axle to cargo CG:

Model	WB (in)	CG _{hl} (in)†
Super Duty F-Series:		
Regular Cab	137.0	132
Regular Cab	140.8	134
Regular Cab	164.8	146
Regular Cab	188.8	158
Regular Cab	200.8	164
SuperCab	158.0	153
SuperCab	161.8	155
Crew Cab	172.4	165
Crew Cab	176.2	167
Crew Cab	200.2	182

† If CG_{hl} is not given in the table or if the location of your cargo is not in the normal cargo area, then your CG_{hl} may be estimated as the distance from the \mathcal{C} of the front wheel to the horizontal midpoint of the cargo area.

TABLE B

CG_{hp} = Horizontal distance from front wheel \mathcal{C} to front passenger load. (Dimensions are inches)

All Super Duty F-Series	= 61.2
-------------------------	--------

TABLE C

CG_{vc} = Vertical distance from ground to chassis CG (Dimensions are inches)

F-250/350 (4X2) SRW > 8500 lb GVWR	= 30.4
F-250/350 (4X4) SRW > 8500 lb GVWR	= 31.4
F-350 (4X2) DRW	= 30.4
F-350 (4X4) DRW	= 31.4
F-450/550 (4X2 & 4X4) DRW	= 35.0

**TABLE D
SUPER DUTY F-SERIES PASSENGER LOAD**

CG _{hp}	GVWR [lb]	P [lb]
61.2 [in]	7717-10,000	400
	10,001-19,000	500

**TABLE E
SUPER DUTY F-SERIES PASSENGER CG_{vp}**

	ALL SEATS	
	4X2	4X4
CG _{vp}	40.3 [in]	43.8 [in]

FMVSS 105 DEFINITIONS AND CALCULATION ILLUSTRATION FOR INCOMPLETE SUPER DUTY F-SERIES

- P** = Passenger load (See Passenger Load Table D page 9).
- CG_v** = Vertical distance from the ground to the center of gravity [inches] of the completed vehicle.
- CG_h** = Horizontal distance from \mathcal{C} of the front wheels to the center of gravity [inches] of the completed vehicle.
- CG_{vb}** = Vertical distance from the ground to the center of gravity of the SUB and/or permanently attached added equipment [inches].
- CG_{vc}** = Vertical distance from the ground to the center of gravity of the chassis [inches] (including cab if original equipment). (Taken from Table C, page 9).
- CG_{hp}** = Horizontal distance from the \mathcal{C} of the front wheels to the P (passenger load). (See Table B, page 9).
- CG_{vp}** = Vertical distance from the ground to the center of gravity of the front and rear seat P (passenger weight). (Taken from Passenger CG_{vp} Table E, page 9).
- W_b** = Weight of the SUB and/or permanently attached added equipment [pounds].
- W_{rb}** = Weight at the rear wheels of the SUB and/or permanently attached added equipment [pounds].
- W_{rc}** = Weight at the rear wheels of the vehicle (chassis and cab) (fuel tanks full) [pounds]. Including option weight.
- W_c** = Weight of the vehicle (chassis and cab) (fuel tanks full) [pounds]. Including option weight.
- WB** = Vehicle wheelbase [inches].
- W_t** = Total unladen weight = (W_b + W_c + P)
- GVWR** = Gross Vehicle Weight Rating of the vehicle [pounds].
- W_l** = Remaining cargo capacity [pounds].
Where: $W_l = GVWR - (W_b + W_c + P)$
- W_{rl}** = Weight of the remaining cargo capacity on the rear wheels [pounds].
$$W_{rl} = \frac{(CG_{hl})W_l}{WB}$$
- CG_{hl}** = Horizontal distance from the \mathcal{C} of the front wheels to the cargo center of gravity [inches]. (Taken from Table A page 9) for many common vehicles. If the CG_{hl} is not given in the table, then it may be estimated as the distance from the \mathcal{C} of the front wheel to the horizontal midpoint of the cargo area.
- SUB** = A Second Unit Body consists of the body structure and/or all the cargo carrying, work performing, and/or load bearing components and/or equipment installed by a subsequent stage manufacturer on an incomplete vehicle, such that the incomplete vehicle becomes a completed vehicle.
- CG_{hc}** = Horizontal distance from the \mathcal{C} of the front wheels to the center of gravity (inches) of the chassis.

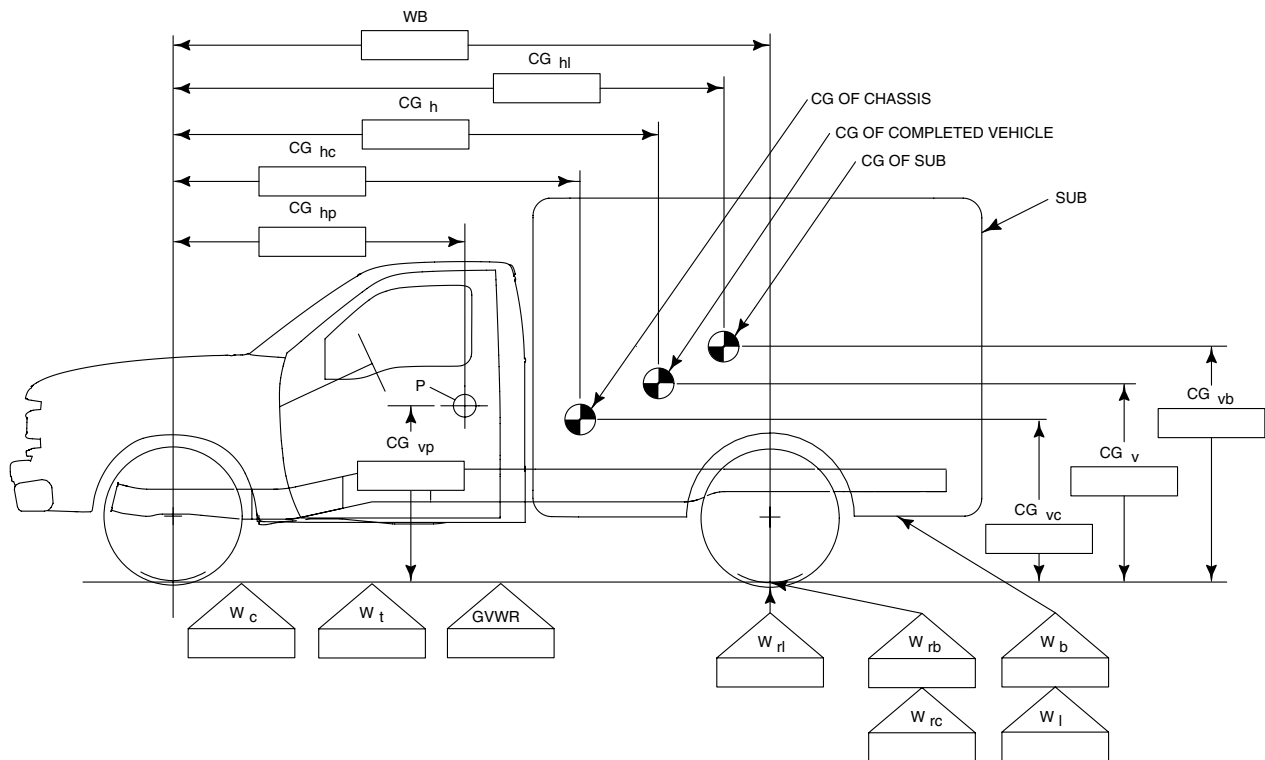

TABLE F
MAXIMUM UNLOADED VEHICLE WEIGHTS WITH SECOND UNIT BODY
(This Weight Information Does Not Apply To Vehicles Over 4536 kg [10,000 lb] GVWR)

MODELS	FRAME WIDTH	SECOND UNIT BODY MAXIMUM CENTER OF GRAVITY HEIGHT† millimeter [inch]	MAX. UNLOADED VEHICLE WEIGHT kilogram [pound]			
			Engine Size – liter [cubic inch]			
			5.4L [330]	6.8L [413]	6.0LD [363]	
PICKUP BOX DELETES	F-250 Regular Cab (4X2) 3480 mm [137 in] WB (56" CA)	Wide	447 [17.6]	3120 [6880]	3120 [6880]	3334 [7350]
	F-250 Regular Cab (4X4) 3480 mm [137 in] WB (56" CA)	Wide	447 [17.6]	3302 [7280]	3302 [7280]	3493 [7700]
	F-250 Super Cab (4X2) 4013 mm [158 in] WB (56" CA)	Wide	610 [24]	3312 [7300]	3312 [7300]	3312 [7300]
	F-250 Super Cab (4X4) 4013 mm [158 in] WB (56" CA)	Wide	610 [24]	3403 [7500]	3403 [7500]	3493 [7700]
	F-250 Crew Cab (4X2) 4379 mm [172.4 in] WB (56" CA)	Wide	610 [24]	3585 [7900]	3585 [7900]	3607 [7950]
	F-250 Crew Cab (4X4) 4379 mm [172.4 in] WB (56" CA)	Wide	610 [24]	3585 [7900]	3585 [7900]	3585 [7900]
	F-350 Regular Cab (4X2) 3480 mm [137 in] WB (56" CA)	Wide	447 [17.6]	3120 [6880]	3120 [6880]	3334 [7350]
	F-350 Regular Cab (4X4) 3480 mm [137 in] WB (56" CA)	Wide	447 [17.6]	3302 [7280]	3302 [7280]	3515 [7750]
	F-350 Super Cab (4X2) 4013 mm [158 in] WB (56" CA)	Wide	610 [24]	3312 [7300]	3312 [7300]	3403 [7500]
	F-350 Super Cab (4X4) 4013 mm [158 in] WB (56" CA)	Wide	610 [24]	3402 [7500]	3403 [7500]	3517 [7750]
	F-350 Crew Cab (4X2) 4379 mm [172.4 in] WB (56" CA)	Wide	610 [24]	3606 [7950]	3606 [7950]	3606 [7950]
	F-350 Crew Cab (4X4) 4379 mm [172.4 in] WB (56" CA)	Wide	610 [24]	3606 [7950]	3606 [7950]	3606 [7950]
CHASSIS CABS	F-350 Regular Cab (4X2) 3576 mm [140.8 in] WB (60" CA)	Narrow	447 [17.6]	3674 [8100]	3674 [8100]	3674 [8100]
	F-350 Regular Cab (4X4) 3576 mm [140.8 in] WB (60" CA)	Narrow	447 [17.6]	3538 [7800]	3538 [7800]	3670 [8090]
	F-350 Super Cab (4X2) 4110 mm [161.8 in] WB (60" CA)	Narrow	610 [24]	3739 [8240]	3739 [8240]	3739 [8240]
	F-350 Super Cab (4X4) 4110 mm [161.8 in] WB (60" CA)	Narrow	610 [24]	3739 [8240]	3739 [8240]	3739 [8240]
	F-350 Crew Cab (4X2) 4475 mm [176.2 in] WB (60" CA)	Narrow	610 [24]	3857 [8500]	3857 [8500]	3857 [8500]
	F-350 Crew Cab (4X4) 4475 mm [176.2 in] WB (60" CA)	Narrow	610 [24]	3766 [8300]	3766 [8300]	3766 [8300]

† Vertical dimensions are measured from the top surface of the frame at a distance approximately 304.8–457.2 mm [12–18 inches] from the rear of the cab.

TABLE G
SUPER DUTY F-SERIES VEHICLES MINIMUM SECOND UNIT BODY WEIGHTS

Wide Frame Pickup Box Deletes
F-250/350 956mm [37.7 in]

Model and Configuration	Body Style	Wheelbase mm [in]	Minimum SUB Weight kg [lb]
F-250/350 SRW	Regular Cab	3480 [137]	172 [380]
	Super Cab	4013 [158]	
	Crew Cab	4379 [172.4]	
F-350 DRW	Regular Cab	3480 [137]	191 [420]
	Super Cab	4013 [158]	
	Crew Cab	4379 [172.4]	

Narrow Frame Chassis Cabs
F-350 866mm [34.1 in] and F-450/550 868mm [34.2 in]

Model and Configuration	Body Style	Wheelbase mm [in]	Minimum SUB Weight kg [lb]
F-350 SRW	Regular Cab	3576 [140.8]	190 [420]
	Super Cab	4110 [161.8]	190 [420]
	Crew Cab	4475 [176.2]	172 [380]
F-350 DRW	Regular Cab	3576 [140.8]	190 [420]
		4186 [164.8]	204 [450]
	Super Cab	4110 [161.8]	190 [420]
	Crew Cab	4475 [176.2]	190 [420]
F-450 DRW	Regular Cab	3576 [140.8]	190 [420]
		4186 [164.8]	204 [450]
		4795 [188.8]	227 [500]
		5100 [200.8]	249 [550]
	Super Cab	4110 [161.8]	190 [420]
	Crew Cab	4475 [176.2]	190 [420]
5085 [200.2]		204 [450]	
F-550 DRW	Regular Cab	3576 [140.8]	190 [240]
		4186 [164.8]	204 [450]
		4795 [188.8]	227 [500]
		5100 [200.8]	249 [550]
	Super Cab	4110 [161.8]	190 [240]
	Crew Cab	4475 [176.2]	190 [240]
5085 [200.2]		204 [450]	

106 The statement below is applicable to the Chassis Cab:

This vehicle, when completed, will conform to Standard 106, Brake Hoses, if the brake hose assemblies supplied by Ford Motor Company are not removed, relocated, altered, or modified and if no brake hose assemblies are added.

108 The statements below, concerning Standard 108 Lamps, Reflective Devices, and Associated Equipment are applicable to the Chassis Cab:

No additional components may be added to the vehicle which require the use of tools to remove such components, for access to the headlamp aiming devices as provided by Ford Motor Company.

Daytime Running Lamps (DRL's); Light Trucks for sale or use in Canada are equipped with DRL's that meet the Canadian DRL requirements. As manufactured for Canada, the F-Series vehicles will meet the FMVSS 108 requirements for DRL's when DRL's are provided.

Conformity with Standard 108, S.12, Headlamp Concealment Devices, are not substantially affected by the design of this incomplete vehicle; accordingly, Ford Motor Company makes no representation as to conformity with this Standard.

108 The statement below is applicable to the Chassis Cab with a GVWR of 4536 kg [10,000 lb] or less and a vehicle width less than 2032 mm [80.00 in]:

This vehicle, when completed, will conform to Standard 108, Lamps, Reflective Devices, and Associated Equipment. If the Chassis Cab Center High Mounted Stop Lamp (CHMSL), when provided, is obstructed from the rear of the completed vehicle it must be replaced with a CHMSL that meets all the requirements of this standard and is connected to the electrical power source as provided by Ford Motor Company. See the figure below for circuit location.

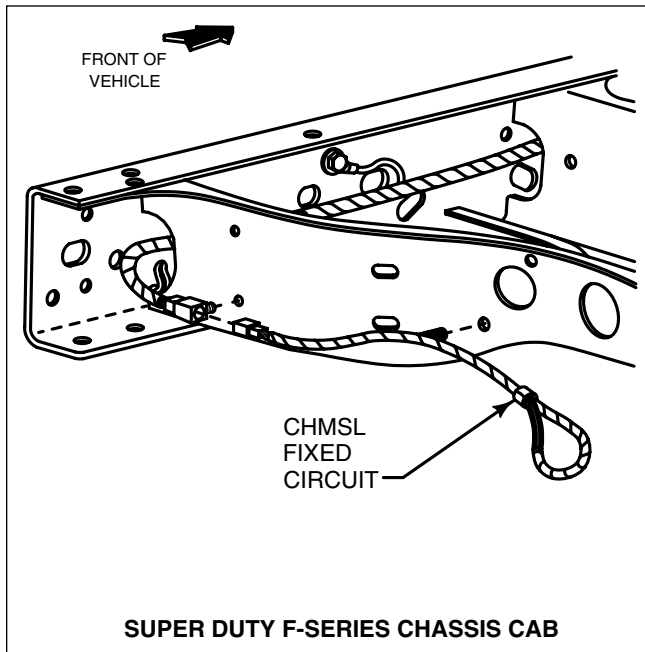

**CENTER HIGH MOUNTED STOP LAMP (CHMSL)
ELECTRICAL CONNECTOR LOCATION**

TABLE H
Standard 108 Lighting Equipment

Item	Super Duty F-Series Completed as Truck or MPV	
	Width less than 2032 mm [80 in]	Width 2032 mm [80 in] or more
Headlamps	S	S
Tail Lamps	S	S
Stop Lamps	S	S
Center High Mounted Stop Lamp (CHMSL)	S	N
License Plate Lamps	S	S
Reflex Reflectors		
– Side Front	S	S
– Side Rear	R	R
– Rear	S	S
Side Marker Lamps		
– Front	S	S
– Rear	R	R
Back-Up Lamps	S	S
Turn Signal Lamps		
– Front	S	S
– Rear	S	S
Turn Signal Operating Unit	S	S
Turn Signal Flasher (2)	S	S
Vehicular Hazard Warning Signal Operating Unit	S	S
Vehicular Hazard Warning Signal Flasher	S	S
Identification Lamps		
– Front	N(1)	S(1)
– Rear	N	R
Clearance Lamps		
– Front	N(1)	S(3)
– Rear	N	R
Parking Lamps	S	N
<p><i>S</i> Required on completed vehicle and supplied with the incomplete vehicle.</p> <p><i>R</i> Required on completed vehicle and <u>not</u> supplied with the incomplete vehicle.</p> <p><i>N</i> Not required for completed vehicle.</p> <p>(1) Supplied on DRW Super Duty F-Series Chassis Cab. Optional on SRW Super Duty F-Series Chassis Cab.</p> <p>(2) Designed for two turn signal lamps per vehicle side (one front and rear). If additional lamps are required, replace the turn signal flasher with one having the correct lamp load rating.</p> <p>(3) If a second unit body width is greater than 2032 mm [80 in] or higher than the chassis cab body, additional clearance lamps may be required that comply with this standard.</p>		

108 The statements below are applicable to the Chassis Cab:

This vehicle, when completed, will conform to Standard 108, Lamps, Reflective Devices, and Associated Equipment, if all the required lighting equipment as indicated in Table H on this page (identified by the codes R and S) is designed and installed in accordance with the requirements of Standard 108 and the directions contained in this statement. Additionally, if the completed vehicle overall length is 9.14 meters [30 feet] or more, intermediate side marker lamps and reflex reflectors (not supplied by Ford Motor Company) are also required for compliance with Standard 108.

The items of equipment which are supplied by Ford Motor Company (identified by the code S in Table H, on this page) are designed and installed to conform to all the requirements of Standard 108. The completed vehicle will conform with these components if the subsequent stage manufacturer does not remove, relocate, alter, or modify such equipment or modify the power supply or wiring to such equipment, and does not complete the body in such a configuration as to impair the visibility and conformity to the photometric requirements of the installed lamps and reflective devices.

Specific requirements for lighting and associated equipment are listed by incomplete vehicle type in Table H on this page.

Lamps, reflective devices, and associated equipment necessary to complete the vehicle from an incomplete vehicle must conform to the equipment, locations, special wiring, visibility, photometric, and performance requirements of Standard 108 and to the applicable SAE standards or recommended practices referenced or sub-referenced in this Standard.

All electrical equipment added to the vehicle by subsequent stage manufacturers must conform to the wiring practices set forth in the Electrical Wiring Section of the *Ford Truck Body Builders Layout Book*.

108 Canadian Requirements:

The preceding statements for Standard 108 are appropriate compliance representations for CMVSS 108, Lighting, and CMVSS 108.1, Headlamps, if this vehicle is manufactured for sale or use in Canada, provided:

- No component of the Daytime Running Lamp (DRL) system is removed, relocated, or modified.

110 U.S. Requirements:

The statement below is applicable to all incomplete vehicles with a GVWR of 4536 kg [10,000 lbs] or less with a completion date starting 09/01/2005:

This incomplete vehicle does not comply to FMVSS 110. In order to comply, the final stage manufacturer must permanently affix a tire placard as specified in paragraph S4.3 of FMVSS 110, typically to the driver's side B-pillar. See below for placard content and note color and format requirements in S4.3.

TIRE AND LOAD INFORMATION			
SEE OWNERS MANUAL FOR ADDITIONAL INFORMATION			
The combined weight of occupants and cargo should never exceed XXX kg or XXX lbs.			
SEATING CAPACITY	TOTAL : 5	FRONT: 2	REAR: 3
ORIGINAL TIRE SIZE		COLD TIRE INFLATION PRESSURE	
FRONT	P195 / 70R14	FRONT	200KPA, 29PSI
REAR	P195 / 70R14	REAR	200KPA, 29PSI
COMPACT TIRE SIZE		COLD TIRE INFLATION PRESSURE	
	T125/70D15		420KPA, 60PSI

111 The statement below is applicable to the Chassis Cab when not equipped with outside mirrors:

Conformity with Standard 111, Rearview Mirrors, is not substantially affected by the design of this incomplete vehicle; accordingly, Ford Motor Company makes no representation as to conformity with this Standard.

111 The statements below are applicable to the Chassis Cab when equipped with a flat glass mirror on the passenger-side:

This vehicle, when completed, will conform to Standard 111, Rearview Mirrors, if:

- The mirrors and their mounts as supplied by Ford Motor Company are not removed, relocated, replaced, or altered.
- No structural modifications are made to the body which would affect the stability of the mirror mounts.
- Any modifications or additions made to the incomplete vehicle must not adversely affect the driver's view to the rear in the outside mirrors along both sides of the vehicle.

113 The statement below is applicable to the Chassis Cab:

This vehicle, when completed, will conform to Standard 113, Hood Latch Systems, if the hood latch system as provided by Ford Motor Company is not removed or altered.

114 The statements below are applicable to the Chassis Cab when completed as either a MPV or a Truck with a GVWR of 4536 kg [10,000 lb] or less:

This vehicle, when completed, will conform to Standard 114, Theft Protection, if the following components, to the extent provided by Ford Motor Company, are not removed, relocated, altered, or modified in any way:

- Steering column locking mechanism system
- Ignition key/transmission shift interlock locking system
- Ignition key-locking system
- Key warning buzzer system

If any of the above components are added to the vehicle they must conform to the requirements of this Standard.

115 Canadian Requirements:

The statements for Part 565.4 are appropriate compliance representations for CMVSS 115, Vehicle Identification Number, if this incomplete vehicle was manufactured for sale or use in Canada.

116 The statement below is applicable to the Chassis Cab:

This vehicle, when completed, will conform to Standard 116, Motor Vehicle Brake Fluids, so long as any brake fluid added or replaced conforms to the DOT 3 specifications of the standard and contaminants are not introduced into the hydraulic brake system.

118 The statement below is applicable to the Chassis Cab not equipped with power operated windows, partition or roof panel systems and their actuation devices when completed as either a MPV or a Truck with a GVWR of 4536 kg [10,000 lb] or less:

Conformity with Standard 118, Power Operated Window, Partition, and Roof Panel Systems, is not substantially affected by the design of this incomplete vehicle; accordingly, Ford Motor Company makes no representation as to conformity with this Standard. If any power operated window, partition, or roof panel systems are installed by subsequent stage manufacturers, they must conform to the requirements of Standard 118.

118 The statement below is applicable to the Chassis Cab equipped with power operated windows, partition or roof panel systems and their actuation devices when completed as either a MPV or a Truck with a GVWR of 4536 kg [10,000 lb] or less:

This vehicle, when completed, will conform to Standard 118, Power Operated Window, Partition, and Roof Panel Systems, if the power operated windows, motors, wiring, and key and switch activation systems, where provided by Ford Motor Company, are not removed, relocated, altered, or modified in any way. If additional power operated window, partition, or roof panel systems are installed by subsequent stage manufacturers, they must conform to the requirements of Standard 118.

119 The statement below is applicable to the Chassis Cab:

All tires supplied by Ford Motor Company are in full conformity with Standard 119, New Pneumatic Tires for Vehicles Other than Passenger Cars.

If additional tires are installed or the existing tires are replaced by subsequent stage manufacturers, they must conform to the requirements of Standard 119.

120 The statement below is applicable to the Chassis Cab:

This vehicle, when completed, will conform to the tire and rim selection requirements of Standard 120, Tire Selection and Rims for Motor Vehicles Other Than Passenger Cars, if the tire and rim assemblies and the Incomplete Vehicle Information label that is affixed to the vehicle are not removed, altered, or replaced.

124 The statements below are applicable to the Chassis Cab:

This vehicle, when completed, will conform to Standard 124, Accelerator Control Systems, if:

- No alterations are made to the accelerator pedal, mounting hardware, adjustable pedal mechanism, or other components of the accelerator control system as installed by Ford Motor Company.
- No equipment is added nor existing equipment modified which would restrict operation of the accelerator control system.
- No alterations are made to the Pedal Position Sensor and all associated hardware and wiring. See the figure below for component identification.

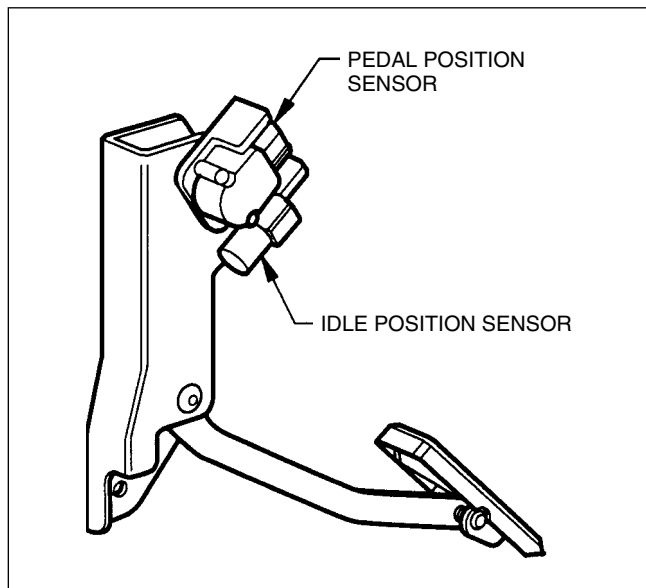

ELECTRONIC ACCELERATOR CONTROL

201 The statements below are applicable to the Chassis Cab with a GVWR of 4536 kg [10,000 lb] or less:

This vehicle, when completed, will conform to Standard 201, Occupant Protection in Interior Impact (excluding U.S. Section 6 requirements addressed separately), if the following components, as provided by Ford Motor Company, are not removed, relocated, altered, or modified in any way:

- Instrument panel
- Interior compartment doors
- Sun visors
- Arm rests

Seat backs of front seats installed by Ford Motor Company are designed to meet the seat back requirements of Standard 201. The seat mounted armrest on an untrimmed front seat must be completed so as to meet the requirements of this Standard.

If any of the above mentioned components (including front seats) are added to the incomplete vehicle by a subsequent stage manufacturer, these components must conform to the requirements of Standard 201 where applicable.

Because conformity of a completed vehicle to the seat back requirements of this standard is dependent upon the location of a seat installed by a subsequent stage manufacturer to the rear of another seat, Ford Motor Company makes no representation as to compliance of a completed vehicle to the seat back requirements if such a seat is installed.

If a vehicle is equipped with a Passenger-side Air Bag Delete option, a right-hand passenger seat should never be installed. If such a seat is installed, Ford Motor Company makes no representation as to the compliance of the completed vehicle to Standard 201.

201U U.S. Requirements (Section S6):

This vehicle when completed, will conform to Standard 201U, ***Occupant Protection in Interior Impact – Upper Interior Head Impact Protection***, if the following components as provided by Ford Motor Company, are not removed, relocated, altered, modified or additions added to the:

- A, B, Rear, or other Pillar and Trim, and Assist Handles
- Seat Belt 'D'-Rings/Adjusters and 'D'-Ring Covers and Sling Systems
- Front or Rear Header and Trim
- Side Rails, Trim, Coat Hooks and Ride Handles
- Upper Roof and Trim
- Exterior Windshield Trim
- Exterior Roof Drain Ditches
- Primary and Secondary Door/Body Seals at all door opening locations in the vehicle
- Sunvisors and attachment hardware
- Changes to the design Seating Reference Point (SRP) with modifications to the Seat System

If any of the above components are added to the incomplete vehicle by a subsequent stage manufacturer, these components must conform to the requirements of Standard 201U where applicable.

202 The statements below are applicable to the Chassis Cab if the GVWR is 4536 kg [10,000 lb] or less:

This vehicle when completed, will conform to Standard 202, Head Restraints, if:

- No alterations are made to the head restraints, the seat assemblies and their anchorages, the floor pan, or floor pan reinforcements.
- The added seat trim, on vehicles equipped with untrimmed front seats, is installed so that the physical dimension requirements for the head restraint, in this Standard, are met.

Any front outboard passenger seat, added to a cutaway equipped with the School Bus Prep Package and when completed as a truck, MPV, or bus (not school bus), must conform with the requirements of this Standard.

203 The statement below is applicable to the Chassis Cab if the GVWR is 4536 kg [10,000 lb] or less:

This vehicle, when completed, will conform to Standard 203, Impact Protection for the Driver from the Steering Control System, if the steering control system is not removed, relocated, altered, or modified in any way and no components or attachments are added to the steering control system that can catch the driver's clothing or jewelry during normal driving maneuvers.

203 Canadian Requirements:

The preceding statements for FMVSS 203 are appropriate compliance representations for CMVSS 203, Driver Impact Protection, if this incomplete vehicle was manufactured for sale or use in Canada. In such a case, the Basic (Stripped) Chassis will comply if no components or attachments are added to the steering control system that can catch the driver's clothing or jewelry during normal driving maneuvers.

204 INFORMATION

Refer to the Design Recommendation section of the *Ford Truck Body Builders Layout Book* for Second Unit Body Attachment information that may aid in designing second unit bodies and their attachments to be compatible with F-Series vehicles.

204 The statements below are applicable to the Chassis Cab if the GVWR is 4536 kg [10,000 lb] or less and the Unloaded Vehicle Weight, when completed, is 2495 kg [5,500 lb] or less:

This vehicle, when completed, will conform to Standard 204, Steering Control Rearward Displacement, if:

- The Unloaded Vehicle Weight does not exceed the appropriate weight on Table F page 11, for F-Series Chassis Cab type vehicles.
- No components are added which could influence the rearward displacement of the steering column.
- The steering column, steering intermediate and coupling shaft, steering wheel, steering gear, steering linkage, related structural components, and attaching hardware, as installed by Ford Motor Company, are not removed, relocated, altered, or modified in any way.
- No alteration or modifications are made to the body chassis, drivetrain, or front suspension from the B-pillar forward.

205 The statement below is applicable to the Chassis Cab:

This vehicle, when completed, will conform to Standard 205, Glazing Materials, if no alterations to or replacements of the installed glazing materials are made and if additional glazing materials installed by a subsequent stage manufacturer conforms to the requirements of Standard 205.

206 The statements below are applicable to the Chassis Cab when completed as a Truck:

This vehicle, when completed, will conform to Standard 206, Door Locks and Door Retention Components, if no alterations or adjustments are made to the door, door pillar structure, door locks, door latches, striker plates, hinges, and attaching hardware as installed by Ford Motor Company.

Any door added to this vehicle by a subsequent stage manufacturer must be equipped with door locks and door retention components that conform with this Standard.

207 The statements below are applicable to the Chassis Cab when equipped with trimmed front seats:

This vehicle, when completed, will conform to Standard 207, Seating Systems, if no alterations are made to the seat assemblies, their anchorages, the floor pan, or floor pan reinforcements. Any seating system added to this vehicle must conform to applicable requirements of this Standard.

208 The statement below is applicable to the Chassis Cab when equipped with Ford trimmed front seats and either the GVWR is over 3856 kg [8,500 lb], the Unloaded Vehicle Weight, when completed, is over 2495 kg [5,500 lb], or the vehicles are manufactured for operation by persons with disabilities:

This vehicle, when completed, will conform to Standard 208, Occupant Crash Protection, if:

- The seat belts, seat belt warning system, passenger air bag deactivation switch (if so equipped), and attaching hardware installed by Ford Motor Company are not removed, relocated, altered, or modified.
- No actions are taken which would impair the integrity of the belt and seat belt warning systems. (A seat belt warning system is not required for a vehicle with a GVWR over 4536 kg [10,000 lb]).
- The Air Bag Supplemental Restraint System Information Labels that are affixed to the front sunvisors are visible and not altered, modified, or removed. If the Air Bag Supplemental Restraint System Information Labels are not affixed to the front visors but shipped in dunnage, the following is necessary to meet Standard 208:
 - The information label must be permanently affixed to each visor in an upright position readable from the driver's or passenger's seating position.
 - If the label is not visible when the visor is stored (up position), an Air Bag Alert Label shall be placed on the visible surface of the visor as specified in Section 4.5.1(c) of Standard 208.
- Front blocker beams may be removed to allow the installation of snow plow attachment hardware. The truck must not be operated without either the blocker beam or snow plow attachment hardware in place.

Any seat belt assemblies added to this vehicle must conform to the applicable requirements of this Standard.

208 Canadian Requirements:

The preceding statements and supporting figures for FMVSS 208, on pages 17-18, are appropriate compliance representations for CMVSS 208, Seat Belt Installation, if this incomplete vehicle was manufactured for sale or use in Canada. In such a case, CMVSS 208 paragraphs (13), (14), and (15) are substituted for the reference to FMVSS 208 Section 7.1; CMVSS 208 paragraph (20) should be substituted for the reference to FMVSS 208 Section 7.2; and CMVSS 208 paragraphs (29), (30), (31), (32), (33), (34), (35), (36), (37), (38), (39), and (40) should be substituted for the reference to FMVSS 208 Section 7.4.

WARNING:

VEHICLES OVER 3856 kg (8,500 lb) GVWR AND 2495 kg (5,500 lb) UVW ARE EQUIPPED WITH SUPPLEMENTAL RESTRAINT SYSTEMS (AIR BAGS) WHICH ARE STANDARD ON THE DRIVER'S SIDE, AND STANDARD OR OPTIONAL FOR THE PASSENGER SIDE. MODIFICATIONS TO THE VEHICLE FORWARD OF THE CRASH SENSOR, SHOWN BELOW, MAY AFFECT THE DEPLOYMENT OF THE AIR BAG WHEN SO EQUIPPED. REFER TO THE FORD TRUCK BODY BUILDERS LAYOUT BOOK FOR SNOW PLOW PREPARATION PACKAGES AND INSTALLATION INSTRUCTIONS WHICH ARE COMPATIBLE WITH AIR BAGS.

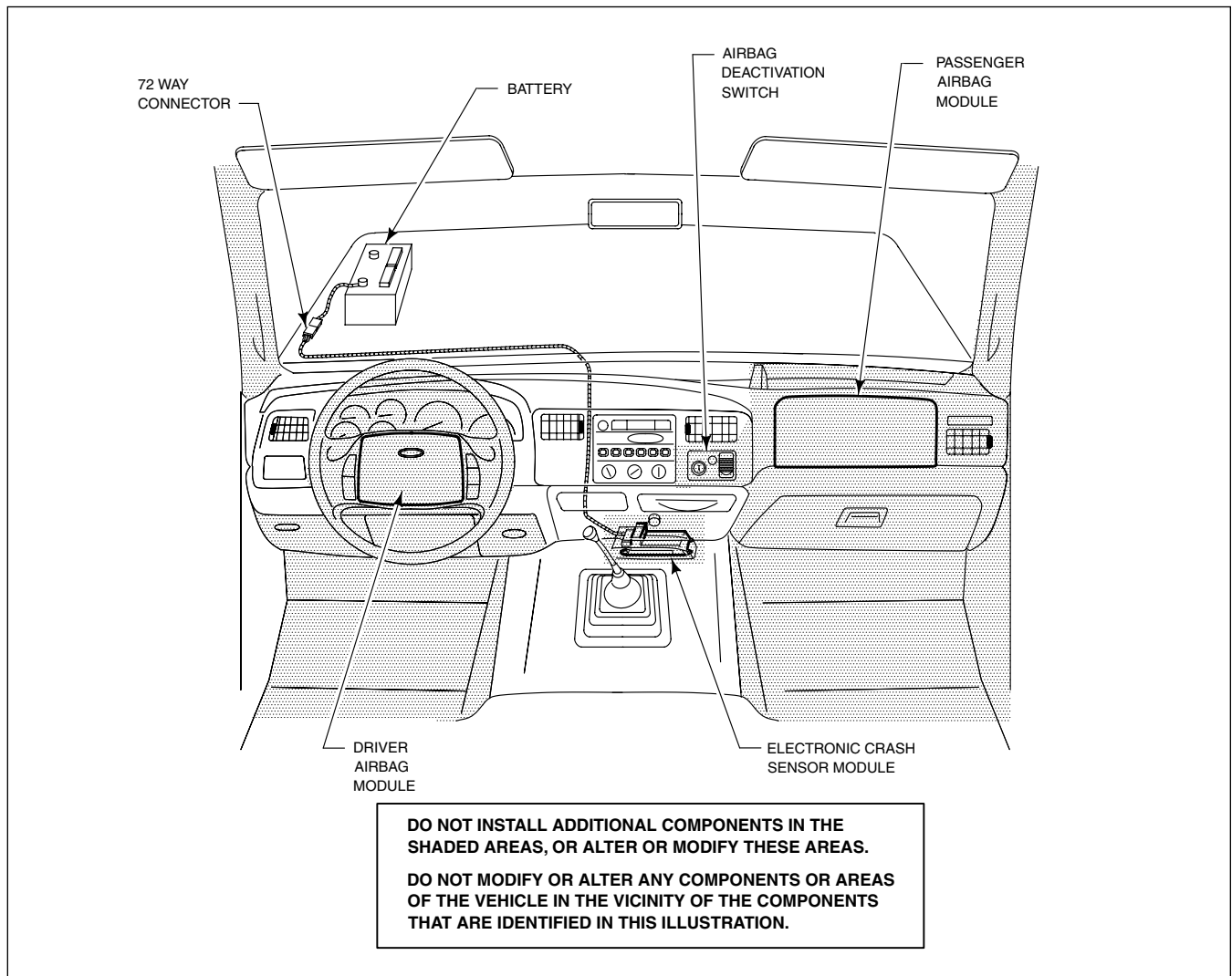

SUPER DUTY F-SERIES OCCUPANT PROTECTION ZONE

209 The statements below are applicable to the Chassis Cab with front seat(s):

This vehicle, when completed, will conform to Standard 209, Seat Belt Assemblies, if:

- No alterations or replacements are made to the seat belt assemblies and attaching hardware.
- No action is taken that would impair the integrity of the seat belt system provided.

Any seat belt assemblies added to a vehicle must conform to the requirements of this Standard.

209 Canadian Requirements:

The preceding statements for FMVSS 209 are appropriate compliance representations for CMVSS 209, Seat Belt Assemblies, if this incomplete vehicle was manufactured for sale or use in Canada. In such a case, CMVSS 209 paragraphs (2) and (93), (4) and (5), (14), (15), and (7) are substituted for the reference to FMVSS 209 Sections 4.1(b), 9c), (e), (g), and (h), respectively.

210 The statements below are applicable to the Chassis Cab:

This vehicle, when completed, will conform to Standard 210, Seat Belt Assembly Anchorages, if:

- No alterations are made to the front seat belt anchorages, front seat belt assemblies, floor pan, floor pan reinforcements, or body mounts.
- No alternations are made to the rear cab panel or roof for the Chassis Cab.

Chassis Cab vehicles may have additional seat belt anchorages for designated seating positions on optional seats not provided on incomplete vehicles. These locations apply to specific hardware and designated seating positions used in Ford completed vehicles. If these anchorages are used without the appropriate Ford seats, seat belt systems, and hardware, Ford Motor Company makes no representation as to conformity with this Standard.

210.1 Canadian Requirements:

The statement below is applicable to the Chassis Cab with a GVWR of 3856 kg [8,500 lb] or less and an unloaded vehicle weight of 2495 kg [5,500 lb] or less.

This vehicle, when completed, will conform to Standard 210.1, User-Ready Tether Anchorages for Restraint Systems, if:

- No alternations are made to the front passenger seat tether anchorages and access to the anchorages is not restricted, and no alterations are made to the seat assemblies, their anchorages, the floor pan, or floor pan reinforcements.

210.2 Canadian Requirements:

The statement below is applicable to the Chassis Cab if the GVWR is 3856 kg [8,500 lb] or less:

This vehicle, when completed, will conform to Standard 210.2, Lower Universal Anchorage Systems for Restraint Systems and Booster Cushions, if:

- No alterations are made to the front passenger seat tether anchorages or LATCH lower anchors, and access to the anchorages is not restricted, and no alterations are made to the seat assemblies, their anchorages, the floor pan, or floor pan reinforcements.

**212/ Note
219**

The terms “body” or “body structure,” in the 212 and 219 statements that follow, include any equipment permanently attached to that body or body structure installed by the subsequent stage manufacturer as well as the basic body or body structure.

**212/ INFORMATION
219**

Refer to the Design Recommendations section in the *Ford Truck Body Builders Layout Book* for Second Unit Body Attachment information to aid in designing second unit bodies and their attachments for compatibility with F-Series vehicles.

**212/ The statements below are applicable to the Chassis
219 Cab if the GVWR is 4536 kg [10,000 lb] or less:**

This vehicle, when completed, will conform to Standard 212 Windshield Mounting, and Standard 219, Windshield Zone Intrusion, if:

- The following windshield system components, related structural components, and hardware, as installed by Ford Motor Company, are not removed, relocated, altered, or modified in any way except as specified in this manual:
 - Windshield and windshield mounting system
 - Cab and front end structural components including the roof, pillars, cowl, cowl reinforcements, hood, doors, fenders, hood restrictors and apron reinforcements, and frame and frame reinforcements
 - Radio antenna and air cleaner assembly
 - Doors and hood mounting, hinging, and latching systems
 - Hood ornamentation
 - Bumper and bumper mounting system †
- No alteration or modification made to the incomplete vehicle as manufactured by Ford Motor Company and no components or structure installed by a subsequent stage manufacturer results in any loss of windshield retention (as defined in Standard 212) or any penetration of the inner surface of the windshield or intrusion into the protected zone (as defined in Standard 219) when the vehicle is impacted in any manner specified by applicable provisions of Standard 212 or Standard 219. Conformity to Standards 212 and 219 for a vehicle having an Unloaded Vehicle Weight greater than 2,495 kg [5,500 lb] is established by testing a representative vehicle at an Unloaded Vehicle Weight of 2,495 kg [5,500 lb] as permitted by s6.1 (b) and s7.7 (b) of Standards 212 and 219, respectively.
- The front end of the body installed by the subsequent stage manufacturer is located at least 76.2 mm [3.0 in] rearward of the rearmost point of the cab.

† Temporary removal of the front bumper and front bumper mounting system during manufacture and reinstallation in accordance with the instructions provided in the *Ford Truck Shop Manual* should not adversely affect the compliance of a completed vehicle to Standards 212 and 219.

- The body installed by the subsequent stage manufacturer is mounted securely and so designed that, when the completed vehicle is impacted in any manner specified by applicable provisions of Standards 212 and 219, body deformation or movement relative to the frame does not result in any separation or loss of body attachment to the frame.
- The maximum SUB weight and SUB center of gravity as installed by the subsequent stage manufacturer and the Unloaded Vehicle Weight does not exceed the values specified in Table F page 11, corresponding to the incomplete vehicle type, wheelbase, and engine size.

212/219 Canadian Requirements:

The preceding statements for FMVSS 212/219 are appropriate compliance representations for CMVSS 212, Windshield Mounting, and CMVSS 219 Windshield Zone Intrusion, if this incomplete vehicle was manufactured for sale or use in Canada. In such a case, CMVSS 212 and 219 paragraphs (5.1) and (8)(b) are substituted for the reference to FMVSS 212 and 219 Sections 6.1(b) and 7.7(b) respectively.

213 The statement below is applicable to the Chassis Cab:

Conformity with Standard 213, Child restraint systems, is not substantially affected by the design of the incomplete vehicle; accordingly Ford Motor Company makes no representation as to conformity with this Standard. Any child restraint system that is added or incorporated into the design of a designated seating position must conform to the requirements of this standard.

214 The statements below are applicable to the Chassis Cab if the GVWR is 4536 kg [10,000 lb] or less:

This vehicle, when completed, will conform to Standard 214, Side Impact Protection, if:

- No alterations, modifications, or replacements are made to the door, surrounding door structure, door hinges, door latches and strikers, or any attaching hardware as provided by Ford Motor Company.

219 See combined statements under “212/219” for all vehicle types.

225 The statement below is applicable to the Chassis Cab:

This vehicle, when completed, will conform to Standard 225, Child Restraint Anchorage Systems, if:

- No alterations are made to the tether anchorages, access to the anchorages is not restricted, and no alterations are made to the seat assemblies, their anchorages, the floor pan, or floor pan reinforcements.

301 Note

The terms “body” or “body structure”, in the 301 statements that follow include not only the basic body or body structure but also any equipment permanently attached to that body or body structure installed by the subsequent stage manufacturer.

301 INFORMATION

The Unloaded Vehicle Weight of the completed vehicle may significantly affect its capability to meet the requirements of Standard 301. Completed vehicles manufactured by Ford Motor Company that are tested to demonstrate compliance with Standard 301 are loaded pursuant to s7.1.6 of the Standard. The test weights of these vehicles comprise the Unloaded Vehicle Weights including the weights of all available regular production options plus the loads specified by s7.1.6. These test weights are less than the respective designated Gross Vehicle Weight Ratings. In addition to the specific statements below, refer to the Design Recommendation section of the *Ford Truck Body Builders Layout Book* for Fuel System information to assist in designing fuel systems and the Second Unit Body Attachment recommendations for information to aid in designing second unit bodies and their attachments to be compatible with Super Duty F-Series vehicles.

301 In addition to the statements pertaining to particular incomplete vehicle types which follow on pages 20-24, the statements immediately below, concerning Standard 301 Fuel System Integrity, apply to all incomplete vehicle types to be completed with a GVWR of 4536 kg [10,000 lb] or less:

- If a fuel line is to be disconnected, refer to the appropriate Ford Service Manual for proper removal and installation procedures.
- When welding near fuel system components, all metallic components must be adequately shielded and protected from heat or weld splatter. All non-metallic components must be removed.

NOTE: *Some incomplete vehicles are equipped with nylon fuel tubes. In the event that the tubes require repair or replacement, only Ford Motor Company approved parts or their equivalents should be used.*

301 The statements below are applicable to the Chassis Cab if the vehicle GVWR is 4536 kg [10,000 lb] or less:

This vehicle, when completed, will conform to Standard 301, Fuel System Integrity, if:

- The following fuel system components as installed by Ford Motor Company are not removed, relocated, altered, or modified in any way (except as specified in the representations following this paragraph):
 - Fuel tank(s) and attachment hardware, including sending unit, vapor valve, fuel tank shield, pressure transducer, and in-tank electric fuel pump
 - Fuel filler cap(s), pipe(s), hose(s), and attachment hardware
 - Fuel lines, routing, and attachments
 - Vapor line(s) and carbon canister – (gasoline engine application)
 - Fuel pump
 - Fuel filter
 - Fuel water separator fuel filter/primer, fuel line heater, and injection pump – (diesel engine only)
 - Fuel shut off switch (inertia switch)
- 137" wheelbase *Regular Cab Pickup Box Delete* units are modified as follows:
 - Bend the lower inboard corner of the left rear outer pillar 90 degrees towards the front of the vehicle along an axis 45 degrees from the cab's horizontal plane (see sketch below)
 - Spot paint repair the area of bend using standard practices including:
 - (a) Clean the surface
 - (b) Sand the surface
 - (c) Prime and topcoat the surface

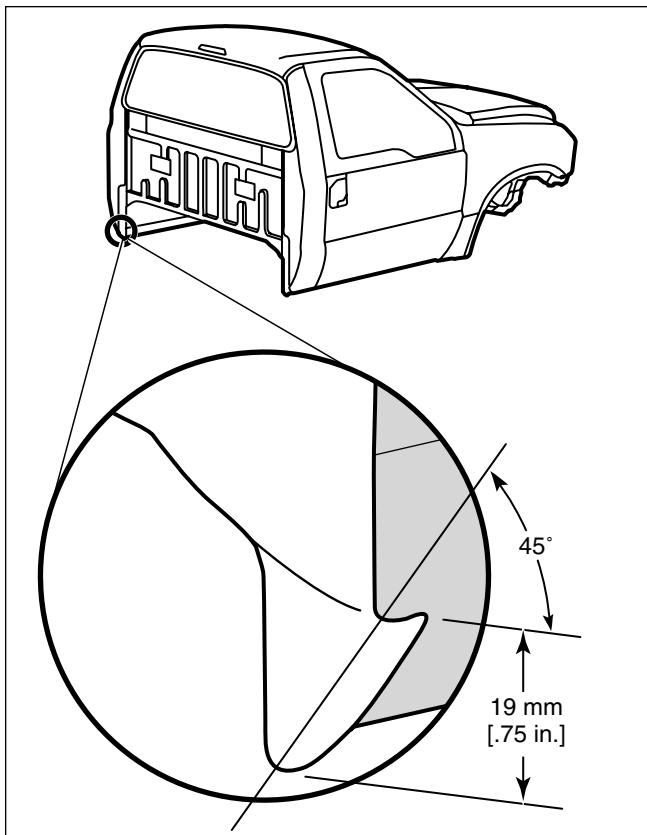

- No other alteration or modification made to the incomplete vehicle as manufactured by Ford Motor Company and no other components or structure installed by a subsequent stage manufacturer result in penetration, separation, or other damage to the fuel system or any portion thereof when the vehicle is tested in any manner specified by applicable provisions of Standard 301.†
- The maximum SUB weight and SUB center of gravity as installed by the subsequent stage manufacturer and the Unloaded Vehicle Weight does not exceed the values specified in Table F on page 11, corresponding to the model, wheelbase, and engine size.
- The body installed by a subsequent stage manufacturer and the Ford installed fuel system components are located and mounted as follows:
 - The body is mounted securely and is so designed that when the completed vehicle is tested in any manner specified by applicable provisions of Standard 301,
 - (a) body components do not contact any fuel system component at any time (other than at the points where the fuel system is permanently attached to the body), and,
 - (b) body deformation or movement relative to the frame does not cause any fuel system component to be penetrated, disconnected, or otherwise damaged.
 - The rear end of the body (excluding the rear bumper) installed by a subsequent stage manufacturer does not extend beyond (overhang) the rear edge of the vehicle frame or frame extension. Any extension of the vehicle frame must be constructed and attached so as to perform as a continuation of the vehicle frame when the completed vehicle is tested in any manner specified by applicable provisions of Standard 301.
 - The front end of the body installed by the subsequent stage manufacturer is located at least 76.2mm [3.0 in] rearward of the rearmost point of the cab.
 - The fuel filler cap(s), pipe(s), hose(s) and attachment hardware are installed as shown in Figures A and B on pages 22 and 23 for Super Duty F-Series vehicles. All components must be securely retained to remain intact when the completed vehicle is tested in any manner specified by applicable provisions of Standard 301.

301 (Continued on Page 24)

† Temporary removal of the front bumper and front bumper mounting system during manufacture and reinstallation in accordance with the instructions provided in the Ford Truck Shop Manual should not adversely affect compliance of the completed vehicle to Standard 301.

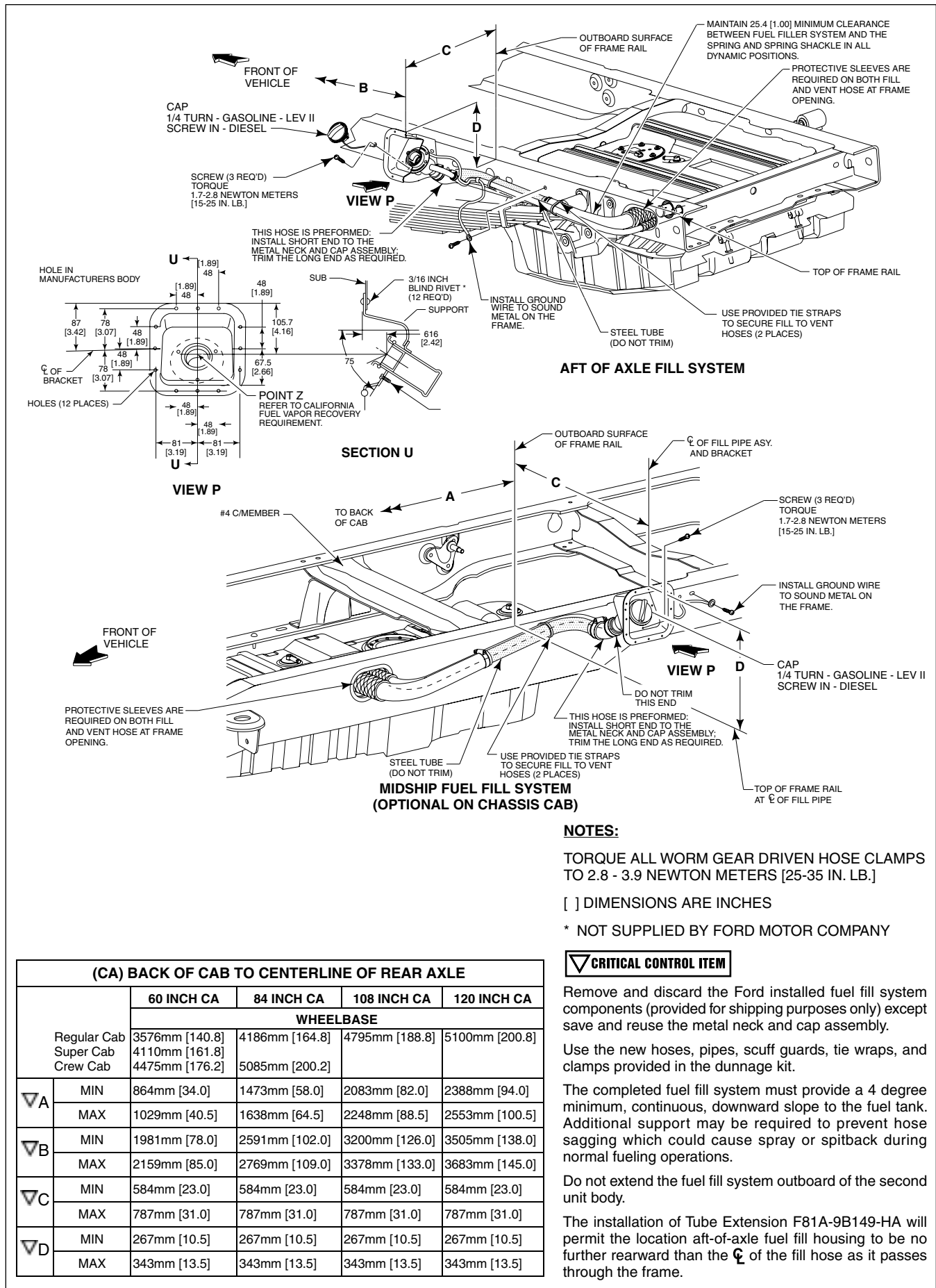
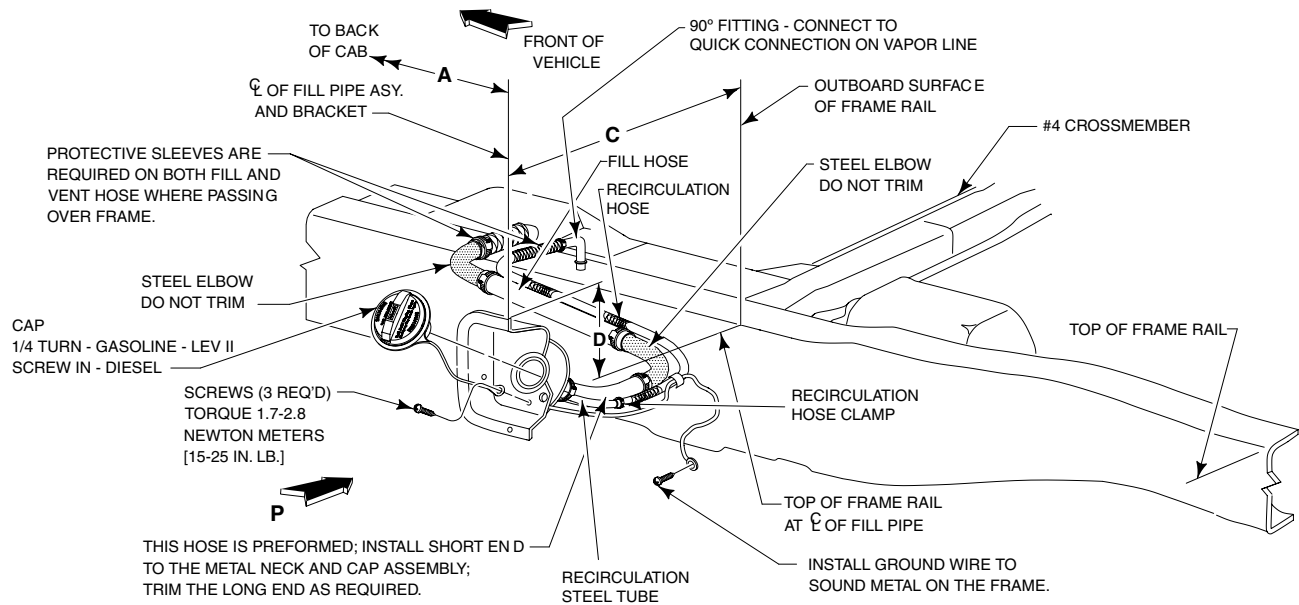
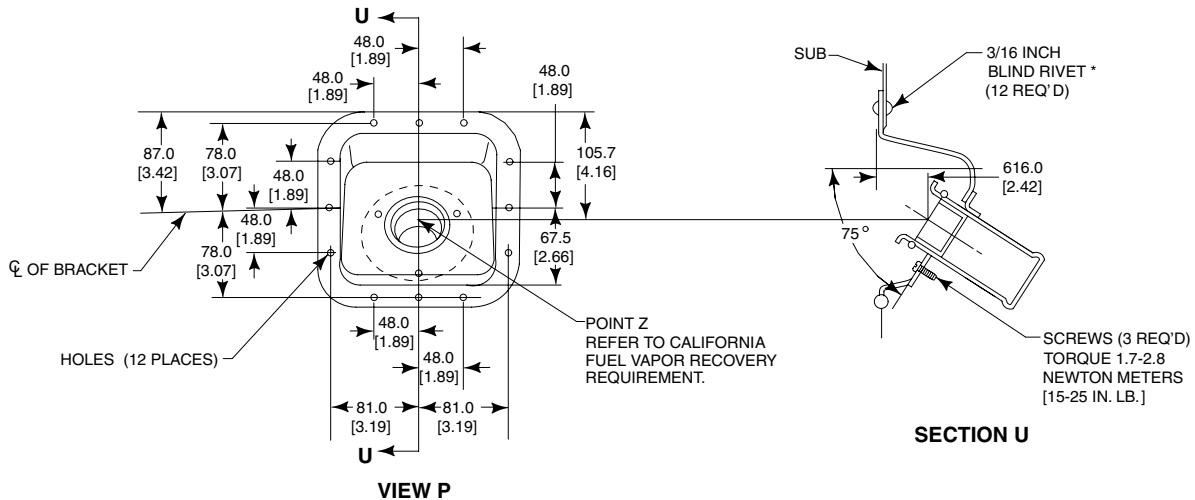

FIGURE A – SUPER DUTY F-SERIES NARROW FRAME CHASSIS CAB FUEL FILLER PIPE INSTALLATION



(CA) BACK OF CAB TO CENTERLINE OF REAR AXLE

		56 INCH CA
		WHEELBASE
	Regular Cab	3480mm [137.0]
	Super Cab	4013mm [158.0]
	Crew Cab	4380mm [172.4]
∇A	MIN	620mm [24.4]
	MAX	923mm [36.7]
∇C	MIN	540mm [21.25]
	MAX	743mm [29.25]
∇D	MIN	267mm [10.5]
	MAX	343mm [13.5]

NOTES:

TORQUE ALL WORM GEAR DRIVEN HOSE CLAMPS TO 2.8 - 3.9 NEWTON METERS [25-35 IN. LB.]

[] DIMENSIONS ARE INCHES

* NOT SUPPLIED BY FORD MOTOR COMPANY

∇ CRITICAL CONTROL ITEM

Remove and discard the Ford installed fuel fill system components (provided for shipping purposes only) except save and reuse the metal neck and cap assembly.

Use the new hoses, pipes, scuff guards, tie wraps, and clamps provided in the dunnage kit.

The completed fuel fill system must provide a 4 degree minimum, continuous, downward slope to the fuel tank. Additional support may be required to prevent hose sagging which could cause spray or spitback during normal fueling operations.

Do not extend the fuel fill system outboard of the second unit body.

FIGURE B – SUPER DUTY F-SERIES WIDE FRAME PICKUP BOX DELETE FUEL FILLER PIPE INSTALLATION

301 (Continued)

301 Canadian Requirements:

The Canadian loading requirements are provided in Section 3.3 of **Test Method 301 Fuel System Integrity**, revised: February 8, 2001, and should be substituted wherever references to FMVSS 301 Section 7.1.6, loading requirements have been made in the statements of conformity for Standard 301.

302 The statement below is applicable to the Chassis Cab:

This vehicle, when completed, will conform with Standard 302, Flammability of Interior Materials, if no alterations are made to those components covered by the Standard which are installed by Ford Motor Company and all components covered by Standard 302, which are added to the incomplete vehicle by subsequent stage manufacturers meet the flammability requirements of the Standard.

1106 Canadian Requirements:

The statements below are applicable to the Chassis Cab with GVW ratings of 4536 kg [10,000 lb] or less:

These vehicles, when completed, will conform to Standard 1106, Noise Emissions, Section 2, if noise control devices or elements of design are not modified removed or rendered inoperative. Examples of such devices or elements of design are:

- Fender apron absorbers, fender apron barriers, underbody noise shields and acoustic absorption material.
- Engine speed governor or electronic control intended to control maximum engine speed.
- Engine air duct, air intake choke or silencer, air cleaner and air cleaner element.
- Exhaust system components including the catalyst inlet pipe, muffler, outlet pipe, resonator and diffuser.
- Engine cooling fan and cooling fan clutch.

1106 Canadian Requirements:

The statements below are applicable to the Chassis Cab with GVW ratings of more than 4536 kg [10,000 lb]:

These vehicles, when completed, will conform to Standard 1106, Noise Emissions, Section 4, if noise control devices or elements of design are not modified removed or rendered inoperative. Examples of such devices or elements of design are:

- Fender apron absorbers, fender apron barriers, underbody noise shields and acoustic absorption material.
- Engine speed governor or electronic control intended to control maximum engine speed.
- Engine air duct, air intake choke or silencer, air cleaner and air cleaner element.
- Exhaust system components including the catalyst inlet pipe, muffler, outlet pipe, resonator and diffuser.
- Engine cooling fan and cooling fan clutch.

CANADIAN VEHICLES

(Vehicles to be completed for sale or use in Canada)

VEHICLE IDENTIFICATION

Refer to the Vehicle Description section of this manual on page 6, for additional information. Incomplete vehicles produced by Ford Motor Company require, for certain applications, optional Prep Packages or trim codes which are listed on the Completed Vehicle Types chart on page 7.

DAYTIME RUNNING LAMP (DRL)

Compliance representations for CMVSS 108, Lighting and CMVSS 108.1, Headlamps, are on page 14. The following items are also required for CMVSS 108 and 108.1 compliance:

- The DRL module circuits are not to be altered.
- DRL module is not to be repositioned.

CANADIAN RADIO FREQUENCY INTERFERENCE (RFI) INFORMATION

All vehicles powered by spark ignition engines (e.g.: gasoline, natural gas, or propane engines) and manufactured in Canada or for sale or use in Canada are subject to the Canadian "Regulations for the Control of Interference to Radio Reception" per Interference-Causing Equipment Standard (ICES-002) and applicable test method according to "CAN/CSA-C108.4-M92". Violation of these regulations is punishable by fine or imprisonment. This Ford-built incomplete vehicle was designed and manufactured to be capable of meeting the regulatory requirements or such modifications thereof as may have been authorized by the Department of Communications. However, because Ford Motor Company has no control over how this incomplete vehicle is completed by subsequent stage manufacturers, Ford Motor Company does not represent that the completed vehicle incorporating the Ford-built components will comply with applicable requirements.

The following information is supplied to subsequent stage manufacturers to help them avoid increasing the RFI emissions of this vehicle in the course of completing it.

For any completed vehicle, additional measures may be needed to adequately suppress RFI emissions. Affected components could include spark plugs, ignition wires, ignition coils, ground straps, ignition component shields, accessory drive belts, instrument voltage regulator suppressor assembly, and ignition coil suppressor assembly.

More specifically:

- All components required to suppress RFI emissions, which are removed during service, repair, or completion of the vehicle, must be reinstalled in the manner in which they were installed by Ford Motor Company.
- Shields on ignition coils must remain installed.
- Replacement spark plugs, ignition wires, and ignition coils must be equivalent in their RFI suppression properties to original equipment.
- Electrical grounds on all components must be retained.
- Metallic components installed on the body or chassis must be grounded to the chassis.
- Electrical circuits added to the vehicle must not be installed near the high voltage ignition components.
- Only "static conductive" accessory drive belts should be used. Fan, water pump, power steering, and other belts should be of the OEM type or equivalent that will not build up a static electrical charge.
- Engine compartment wiring must not be rerouted in any manner.
- The Powertrain Control Module (PCM) must not be relocated from the position as installed by Ford Motor Company.

EMISSION CERTIFICATION INFORMATION

CAUTION:

U.S.:

2006 MODEL YEAR VEHICLES ARE EMISSION CERTIFIED FOR REGISTRATION IN SPECIFIC AREAS OF THE UNITED STATES. FOR EXAMPLE, **VEHICLES CERTIFIED AND LABELED FOR SALE IN CALIFORNIA CAN NOT BE SOLD IN THE STATES THAT REQUIRE FEDERALLY CERTIFIED VEHICLES AND VEHICLES CERTIFIED TO FEDERAL STANDARDS CAN NOT BE SOLD IN STATES THAT REQUIRE CALIFORNIA CERTIFIED VEHICLES.** IT IS THE SUBSEQUENT STAGE MANUFACTURER'S RESPONSIBILITY TO PURCHASE A VEHICLE CERTIFIED FOR THE STATE/AREA IN WHICH THE VEHICLE WILL BE SOLD. EPA HAS STATED THAT UNDER CERTAIN CIRCUMSTANCES THEY WILL NOT ENFORCE THESE REQUIREMENTS. FOR FURTHER GUIDANCE CONSULT EPA'S "POLICY ON CROSS BORDER SALES OF CALIFORNIA VEHICLES."

CANADA:

IF THE COMPLETED VEHICLE IS INTENDED FOR SALE OR USE IN CANADA, THE INTERMEDIATE OR FINAL STAGE MANUFACTURER MUST INSURE THAT THE INCOMPLETE VEHICLE IS ORDERED THROUGH A CANADIAN DEALER OR IS ORDERED FROM FORD MOTOR COMPANY WITH THE APPROPRIATE CANADIAN MARKET OPTION CODE. FAILURE TO DO SO MAY RESULT IN AN INCOMPLETE VEHICLE THAT IS BUILT WITH AN EMISSIONS SYSTEM AND LABELING THAT ARE NOT IN COMPLIANCE WITH THE REQUIREMENTS OF THE CANADIAN ENVIRONMENTAL PROTECTION ACT.

FRONTAL AREA AND WEIGHT RESTRICTIONS:

Starting in 2005, some heavy-duty *incomplete* vehicles are certified using chassis certification protocol and will require vehicle weight and frontal area restrictions (to retain emission certification). If your vehicle is affected, the frontal area and unloaded vehicle weight information will be found on the VECI label, which is located in the engine compartment. Incomplete vehicles with engines certified using heavy-duty engine protocol are not limited by weight and frontal area restrictions for exhaust emissions.

It is important that the final stage manufacturer observe vehicle restrictions from vehicle safety requirements, etc., which are located elsewhere in this manual. Additional emissions certification information is contained in the *Ford Truck Body Builders Layout Book* for the model year and type of this incomplete vehicle.

IMPORTANT:

For purposes of Government Regulation, a body builder, installer, or any subsequent manufacturer may be considered a manufacturer.

HIGH ALTITUDE REQUIREMENTS

United States Environmental Protection Agency regulations for the 2006 model year do not contain unique emission certification requirements for trucks that will be sold or delivered to customers for principal use above 1,219 m [4,000 ft.].

EMISSION CONTROL HARDWARE

Any body builder, installer, or subsequent stage manufacturer must also assure that all emission control hardware furnished with incomplete vehicles is on the vehicle and is operational and that applicable instructions for incorporating such hardware into the completed vehicle's electrical or mechanical systems are strictly followed.

Further, to avoid any question of certification coverage, approval of any modification or use of an engine or vehicle which may render inoperative any of the emission control components must be obtained from the United States Environmental Protection Agency by the manufacturer making such modification or use prior to distribution, sale, offering for sale, introduction, or delivery for introduction of the subject vehicle into U.S. commerce. Additionally, the manufacturer making such modification or use must obtain approval from the California Air Resources Board if the new vehicle will be delivered for sale or use in the State of California.

UNLEADED GASOLINE LABEL

Regulations no longer require the manufacturer to affix permanent labels reading "Unleaded Gasoline Only" or "Unleaded Fuel Only" to vehicles destined for sale in the United States or Canada. Such labels may however be required for vehicles sold into other markets. It is the responsibility of the body builder, installer, or any subsequent manufacturer to properly label vehicles for the market in which they are sold.

EXTERIOR NOISE

New vehicles which have a gross vehicle weight rating in excess of 4536 kg [10,000 lb], include a partially or wholly enclosed operator's compartment, and are manufactured for use in the United States, must comply with U.S. Environmental Protection Agency's exterior noise emission regulations for medium and heavy trucks (40 CFR Part 205, Subpart B) which establish a noise emission limit of 80 dB (A).

TAMPERING WITH NOISE CONTROLS

Federal law prohibits the removal or rendering inoperative by any person, other than for purposes of maintenance, repair, or replacement, of any device or element of design incorporated into such vehicle for the purpose of noise control prior to its sale or delivery to the ultimate purchaser or while it is in use. Federal Law also prohibits the use of such vehicle after such device or element of design has been removed or rendered inoperative by any person.

Among those acts presumed to constitute tampering are the acts listed below:

- Removal of fender apron absorbers, fender apron barriers, underbody noise shields, or acoustical absorptive material.
- Removal of or rendering inoperative the engine speed governor so as to allow engine speed to exceed manufacturer's specifications.
- Removal or modification of air duct, air intake choke or silencer, air cleaner, or air cleaner element.
- Removal of, or rendering inoperative, exhaust system components including the catalyst inlet pipe, muffler, outlet pipe, resonator, or diffuser.
- Removal of the fan shroud. Removal of or rendering inoperative the fan clutch.

New vehicles manufactured for sale in Canada must comply with applicable provisions of Canada Motor Vehicle Safety Standard 1106, Noise.

Additional noise emissions information is contained in the *Ford Truck Body Builders Layout Book*.

WARRANTY AND MAINTENANCE

A copy of the appropriate *Ford Truck Owners Guide and Warranty Facts Booklet* must be installed in every vehicle prior to sale to the ultimate purchaser in order to provide emission systems warranty information and maintenance schedules. It also provides, where required by EPA noise control regulations for vehicles having GVWR over 4536 kg [10,000 lb], noise emissions warranty information, instructions for maintenance, use, and repair of vehicle noise emission control systems, a maintenance record format, and list of prohibited tampering acts.

EVAPORATIVE EMISSIONS

All 2006 Federal light and heavy duty trucks and all California vehicles with gasoline engines are required to comply with evaporative emissions requirements established by the Environmental Protection Agency or the California Air Resources Board. Production fuel systems supplied on incomplete 2006 model year trucks manufactured by Ford Motor Company comply with these requirements. **If the subsequent stage manufacturer adds to or modifies the fuel system in any manner, it becomes the responsibility of the modifier to assure compliance with the applicable regulations.** Refer to the Design Recommendation section of the *Ford Truck Body Builders Layout Book*, for additional Fuel System Evaporative Emissions information.

MALFUNCTION INDICATOR LIGHT (MIL)

The "Malfunction Indicator Light" is used to indicate malfunctions of the Electronic Engine Control System and certain emissions-related components. For all incomplete vehicles, except Basic (Stripped) Chassis (which is not equipped with an instrument panel), it is Ford installed and operational.

POWER TAKE-OFF CIRCUIT

A wire located under the instrument panel labeled "Power Take-Off Circuit" is provided to minimize the inadvertent illumination of the "Service Engine Soon" while the PTO is engaged. Refer to the Design Recommendation section of the *Ford Truck Body Builders Layout Book*, for Power Take-off Installations information that will locate the Ford provided circuit. Connect the wire to the Power Take-Off Circuit as instructed and isolate the wire labeled "Power Take-Off Circuit" from the solenoid to prevent damage to the Power Control Module (PCM).

OZONE DEPLETING SUBSTANCE (ODS)

The Clean Air Act of 1990, Section 611 requires any product (i.e., completed vehicle) containing or manufactured with any Class I Ozone Depleting Substance on, or after May 15, 1993 must be identified with a "clearly and conspicuously attached label."

Ford Motor Company has eliminated Class I ODS from its manufacturing processes. All 2006 Ford Truck incomplete vehicles will not have Class I ODS content.

Manufacturers, including subsequent stage manufacturers, are required to label their products if the product, including any component (whether manufactured by that manufacturer or not), contains a Class I ODS or if the manufacturer used a Class I ODS in the manufacturing of the product. In the case where Ford Motor Company provides a label saying the incomplete vehicle contains a Class I ODS that information must be placed on the product warning label. (See EPA regulation on wording, placement, size, and combining labels.) In Canada consult the appropriate Provincial or Territorial Ministry of Environment.

EMISSION CONTROL INFORMATION LABEL

To meet United States Environmental Protection Agency regulations, the Important Vehicle Information (tune-up and fuel tank capacity) labels must be affixed in a location that is readily visible after installation and in such a manner that it cannot be removed without destroying or defacing the label. The label shall not be affixed to any equipment that is easily detached from the vehicle.

When emission control labels are supplied but not attached to the vehicle (i.e., tune-up label or fuel tank label), they must be permanently mounted in a readily visible location to meet the preceding requirements. In addition, whether the label is already affixed or to be affixed, no components shall be installed which visibly obscure the label in any way that fails to satisfy the visibility requirements described in the California Emission Control Label Specifications. For Canadian requirements consult Section 1100 8 (1) (d) (i), (ii), & (iii), as applicable.

CALIFORNIA FUEL VAPOR RECOVERY

California regulations require that the vehicle fuel systems be designed to accommodate a vapor recovery fueling nozzle including unobstructed access to the fill pipe. Fuel filler pipes installed per the figures on pages 22 and 23 will comply with the "Specifications For Fill Pipes and Openings of Motor Vehicle Fuel Tanks" referenced in Title 13 California Administrative Code provided no part of the aftermarket body, as installed, intrudes within a 254mm [10 in] radius cylinder which has its axis parallel to the ground at point "Z" (Figure A on page 22 illustrates a typical point Z). The cylindrical zone uses the axis described above, starts at the outer most surface of the Ford supplied fuel filler housing, and projects outward (away from the frame). The fuel pipe housing component is shown on the referenced figures and is attached to the aftermarket body via 3/16 inch diameter rivets.

CALIFORNIA MOTOR VEHICLE EMISSION CONTROL LABEL

To meet California emission certification regulations, the Emission Control Information (tune-up) label must be welded, riveted, or otherwise permanently attached to an area within the engine compartment or to the engine in such a way that it will be readily visible to the average person after installation of the engine in a vehicle. In selecting an acceptable location, the manufacturer shall consider the possibility of accidental damage (e.g., possibility of tools or sharp instruments coming in contact with the label). The label shall be affixed in such a manner that it cannot be removed without being destroyed or defaced, and shall not be affixed to any part which is likely to be replaced during the vehicle's useful life. For motor vehicles rated at 6350 kg [14,000 lb] GVWR or less, the label shall not be affixed to any equipment which is easily detached from the vehicle. As used in these specifications, readily visible to the average person shall mean that the label shall be readable from a distance of 460 mm [18 in] without any obstructions from vehicle or engine parts (including all manufacturer available optional equipment), except for flexible parts, (e.g., vacuum hoses, ignition wires). Alternately, information required by these specifications to be printed on the label shall be no smaller than 8 point type size provided that no vehicle or engine parts (including all manufacturer available optional equipment), except for flexible parts that can be moved out of the way without disconnection, obstruct the label.

Completed vehicles for retail sale in California require a machine-readable Vehicle Identification Number (VIN) bar-code label made of paper, plastic, metal, or other permanent material which shall be affixed in a readily visible location to either the door-latch post next to the driver's seating position, the door edge that meets this door-latch post, or above the instrument panel in a location clearly visible through the lower left corner of the windshield.

- All incomplete vehicles except Basic (Stripped) Chassis type vehicles will conform to this standard.

For the Vehicle Emission Control (VEC) and VIN labels, sufficient clearance shall be provided to use a non-contact bar-code Reading Wand. For the tune-up label and vacuum hose routing diagram label, the label and any adhesives used shall be designed to withstand typical vehicle environment conditions in the area where the label is attached for the vehicle's total expected life. Typical vehicle environmental conditions shall include, but are not limited to, exposure to engine lubricants and coolants (e.g., gasoline, motor oil, brake fluids, water, ethylene glycol), under hood temperatures, steam cleaning, and paints or paint solvents.

RADIO FREQUENCY INTERFERENCE (RFI)

The ignition system on your vehicle has been designed to be capable of compliance with RFI requirements established by the Canadian government. However, because Ford Motor Company has no control over how an incomplete vehicle is completed by subsequent stage manufacturers, Ford Motor Company does not represent that the completed vehicle incorporating the Ford-built components will comply with those requirements. Any ignition system component (i.e.: spark plugs, ignition wiring, coil suppressor assembly, etc.) that is replaced should be replaced by the same Ford Motor Company part number or equivalent to maintain RFI suppression.

While there are currently no RFI regulations in the United States specifically applicable to automotive ignition systems, all Ford Motor Company trucks built with an ignition system use the same or equivalent components to those supplied on Canadian vehicles.

Ford Motor Company recommends that all ignition system service be performed at a Ford authorized service facility to help hold RFI emissions levels to a minimum.

Additional RFI information is contained on page 25 of this manual.

Devices that emit radio frequency (RF) energy such as AM/FM radios, mobile telecommunications systems (two-way radios, telephones), and radio controlled security systems are subject to the rules and regulations of the Federal Communications Communication (FCC), including 47 CFR Parts 2 and 15. Any such system installed in a vehicle should comply with those rules and should be installed only by a qualified technician. In addition, to ensure continued compliance with the FCC's regulations, RF devices must not be modified or changed in a manner not expressly approved by Ford Motor Company Mobile Communication Systems. RF devices particularly, if not properly installed, may adversely affect the operation of the vehicle. For example, such systems when operated may cause the engine to stumble or stall. In addition, such systems themselves may be damaged or their operation affected by the operation of the vehicle. (Citizens Band [CB] transceivers, garage door openers, and other transmitters whose power output is 5 watts or less, ordinarily will NOT affect vehicle operation.)

Because Ford Motor Company has no control over the operation or manufacture of such systems or their installation, Ford Motor Company cannot assume responsibility for any adverse effects or damage if this equipment is used.

REFERENCE INFORMATION

FORD TRUCK BODY BUILDERS LAYOUT BOOK

Throughout this manual you will find references to information found in the *Ford Truck Body Builders Layout Book*. Additional Design Recommendations and specifications are also provided to assist subsequent stage manufacturers in completing chassis cab and incomplete vehicles. To obtain a free copy of this publication on CD-ROM or to receive an order form for additional CD-ROM's or books please visit our website at www.fleet.ford.com/truckbbas. Under Publications select Body Builders Order Forms. All dealer requests can be handled online. All other U.S. orders should be faxed to (734) 713-2971. Canadian orders should be faxed to (905) 670-0844.

FORD SERVICE PUBLICATIONS

Many Ford Service Publications pertain to a specific Model Year and vehicle types. The following publications are a few of many manuals which are available from Helm Incorporated; call: 1-800-782-4356

- Ford Truck Shop Manuals
- Ford Towing Manual
- Ford Electrical & Vacuum Trouble Shooting Manual
- Ford Wiring Diagram

FORD TRUCK BODY BUILDER ADVISORY SERVICE

The Ford Truck Body Builder Advisory Service may be consulted regarding information contained in this manual. Call 1-877-840-4338 or e-mail bbasqa@ford.com for assistance or Fax inquiries to (313) 594-2633 accompanied with a cover sheet indicating "Attention to: Ford Truck Body Builder Advisory Service," along with your name, address and telephone number.



FORD MOTOR COMPANY
THE AMERICAN ROAD
DEARBORN, MI 48121

FORD MOTOR COMPANY OF CANADA LIMITED
THE CANADIAN ROAD
OAKVILLE, ONTARIO L6J 5E4