



ES30-ISAP Pan and Tilt System



C312M-A (12/02)

CONTENTS

Section	Page
DESCRIPTION	4
MODELS	4
INSTALLATION	5
POD 100	5
PAN AND TILT	6
TXB SERIES TRANSLATOR BOARD INSTALLATION (OPTIONAL)	9
HOW TO REMOVE THE PAN AND TILT COVER	9
HOW TO REINSTALL THE PAN AND TILT COVER	9
CAMERA OPERATION (POD 100 THERMAL IMAGER)	11
OPERATION	11
POWER-UP DISPLAY	11
PAN AND TILT OPERATION	11
OPERATING NOTES	12
ENVIRONMENTAL RANGE	12
PAN AND TILT FUNCTIONS	12
PAN, SCAN, AND TILT SPEEDS	12
LENS FUNCTIONS	12
PRESET FUNCTIONS	12
RANDOM, FRAME, AND AUTO SCANNING	13
ZONES	13
PATTERNS	13
PARK	13
QUICK START GUIDE – SYSTEM SETUP	14
PROGRAMMING GUIDE – ES30-ISAP PAN AND AND TILT SYSTEM	14
HOW TO ACCESS THE MAIN MENU (PRESET 95)	15
CM6700/CM6800	15
KBD200A/KBD300A (DIRECT MODE ONLY)	15
CM9500	15
CM9740/CM9760	15
KBD4000/KBD4002 (GENEX® MULTIPLEXER)	15
MPT9500	15
EXTENDED COAXITRON OR RS-485 MODE	15
PELCONET™	15
CAMERA	16
LIMIT STOPS	17
TURNING LIMIT STOPS ON OR OFF	17
PROGRAMMING LIMIT STOPS	17
Manual Limit Stops	17
Presets	17
Limit Stops Menu	17
Clear Manual Stops	18
SCAN LIMIT STOPS	18
Presets	18
Limit Stops Menu	18
Clear Scan Limit Stops	18
LINE SYNCHRONIZATION	19
PARK TIME MINUTES	20
PATTERN LENGTH	20
POWER-UP MODE	21
PROPORTIONAL PAN	22
SCAN SPEED	23
SPEED PROFILE	23
ZONES	24
ZONE BLANK	24

PRODUCT SUPPORT	25
ES30-ISAP PAN AND TILT SYSTEM CONTACT:	25
POD 100 THERMAL IMAGER (CAMERA) CONTACT:	25
APPENDIX	26
SPECIFICATIONS (PAN AND TILT SYSTEM ONLY)	30
REGULATORY NOTICES	31
WARRANTY AND RETURN INFORMATION	31

LIST OF ILLUSTRATIONS

Figure		Page
1	POD 100 Attachment to the Tilt Table	5
2	Cable Connections	5
3	Transformer Removal	6
4	Base Installation on Mount	6
5	Transformer Reinstallation	7
6	Pan and Tilt Installation	8
7	Pan and Tilt Cover Removal	9
8	Pan and Tilt Cover Seating	9
9	Pan and Tilt Cover Reinstallation	10

LIST OF TABLES

Table		Page
A	Switch Settings for SW1	26
B	Switch Settings for SW2	27

DESCRIPTION

The ES30-ISAP is an innovative addition to the Esprit® Series Positioning System family designed specifically for the POD 100 Thermal Imager (not supplied). The system includes the Esprit receiver, pan and tilt, power supply, and an exclusively designed connector and mount for the thermal imager.

MODELS

ES30-ISAP-2	Pan/tilt, receiver, and 24 VAC power supply, no mount
ES30-ISAP-5	Same as ES30-ISAP-2 except 120/230 VAC
ES30-ISAP-2N	Pan/tilt, receiver, and 24 VAC power supply, with pedestal adapter plate
ES30-ISAP-5N	Same as ES30-ISAP-2N except 120/230 VAC
ES30-ISAP-2W	Pan/tilt, receiver, and 24 VAC power supply, with wall mount
ES30-ISAP-5W	Same as ES30-ISAP-2W except 120/230 VAC

INSTALLATION

POD 100

1. Refer to Figure 1 and attach the POD 100 to the tilt table of the Esprit with the 1/4-20 x .50-inch screw (supplied).

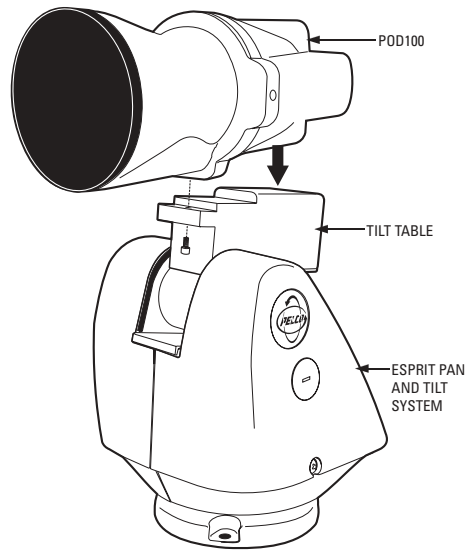

Figure 1. POD 100 Attachment to the Tilt Table

2. Refer to Figure 2 and attach the harness cable to the system.

NOTE: The tilt table, power, and communication pin connectors are marked with red alignment dots. To install a pin connector align the red dot of the female connector with the red dot of the male connector and then lightly push the connector until it locks in place.

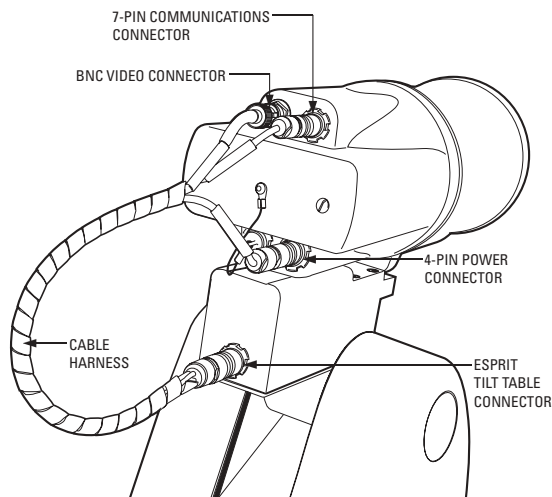

Figure 2. Cable Connections

PAN AND TILT

1. Remove the transformer module from the base of the system by loosening the four Phillips screws and lifting the module.

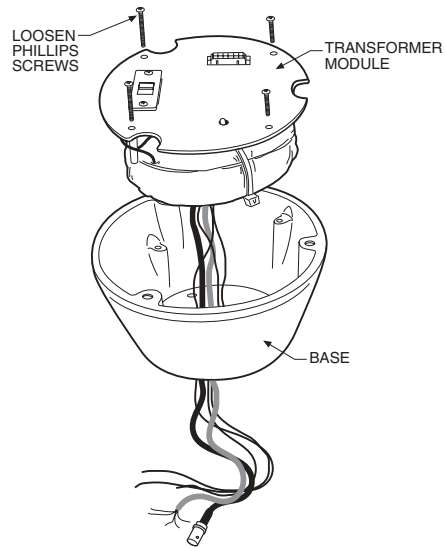

Figure 3. Transformer Removal

2. Attach the base of the system to an Esprit mount (EWM or EPP) with the three flathead 10-32 x 1/2-inch screws and washers (supplied).

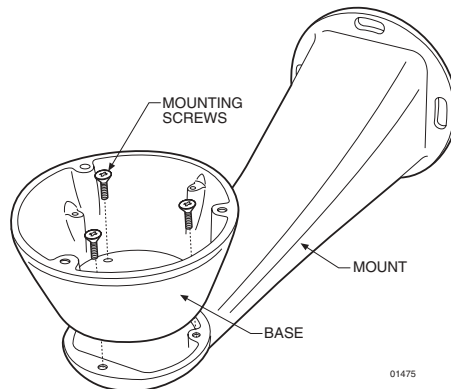

Figure 4. Base Installation on Mount

NOTE: The illustration shows the ES30-ISAP Pan and Tilt System mounted to an EWM wall mount.

3. Route the wires and cables from the transformer module through the center of the Esprit mount. Reinstall the transformer module into the base. The transformer module can be positioned in the mount base in only one orientation.

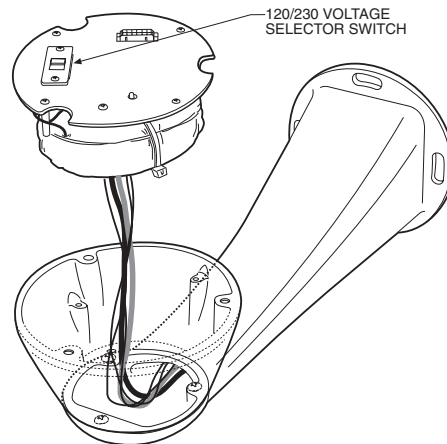

Figure 5. Transformer Reinstallation

4. ES30-ISAP-5 Model Only – Set the 120/230 voltage selector switch on the transformer to the appropriate voltage.
5. Connect wires and cables.

- a. Connect to power.

120/230 VAC

Black wire	Input (AC Line)
White wire	AC Neutral
Green wire	Ground

24 VAC

White wire	Input (AC Line)
White wire	AC Neutral
Green wire	Ground

- b. Connect the video coaxial cable to the BNC connector.
- c. Connect the wiring for a two-wire or four-wire control system. This step does not apply to Coaxitron® control systems.

Green wire	RX-
Red wire	RX+
Black wire	TX-
White wire	TX+

6. Install mount; refer to the installation manual supplied with the mount for instructions.
7. Turn on the power. If the red LED lights, turn off the power and proceed to the next step.

8. Plug the male Esprit system connector, located on the bottom of the pan and tilt, into the female Esprit system connector located on the transformer module. Align the pan and tilt part number with the alignment label on the base, and then attach the pan and tilt to the base with three 1/4-20 nuts and washers (supplied).

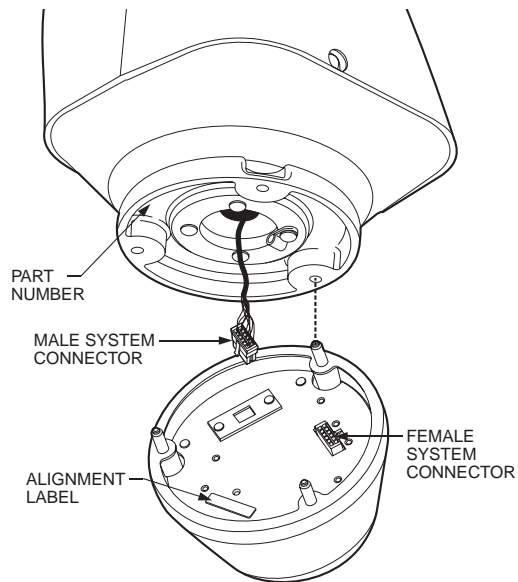

Figure 6. Pan and Tilt Installation

9. Set the receiver address and system baud rate by configuring DIP switches SW1 and SW2.

To set the DIP switches:

- a. Remove the plug from the left cover of the pan and tilt. It is not necessary to remove the pan and tilt cover.
- b. Set the baud rate (SW1) and receiver address (SW2). For switch settings refer to Tables A and B in the *Appendix*.
- c. Replace the plug.

NOTE: Switch settings have no effect on Coaxitron control signals. The Esprit will sense and automatically select input from Coaxitron control signals in either standard or extended mode.

TXB SERIES TRANSLATOR BOARD INSTALLATION (OPTIONAL)

Pelco's TXB Series allows controllers from other companies to communicate with the Esprit system.

To install a TXB Series board, remove the left cover of the pan and tilt. Once the cover is removed, refer to the manual supplied with the translator board to complete the installation.

HOW TO REMOVE THE PAN AND TILT COVER

1. Unscrew the Phillips head screw located on the left cover of the pan and tilt.
2. Remove cover and place to the side.

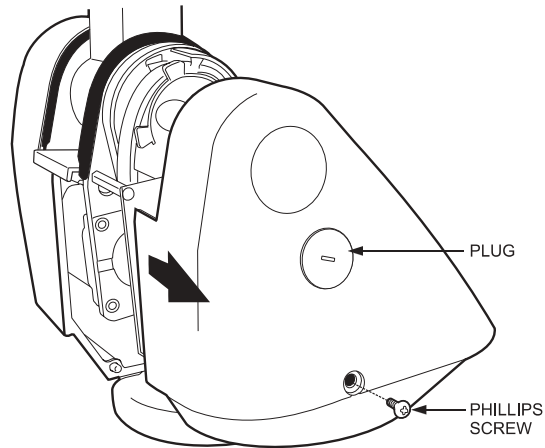

Figure 7. Pan and Tilt Cover Removal

HOW TO REINSTALL THE PAN AND TILT COVER

The pan and tilt covers must be seated properly and have a tight seal all the way around when installed.

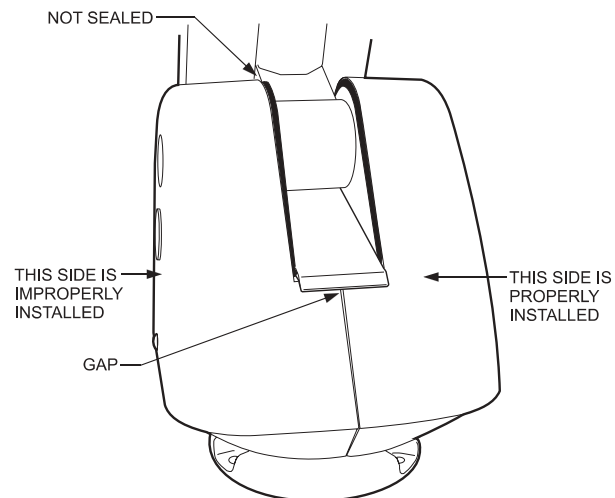

Figure 8. Pan and Tilt Cover Seating

To reinstall the pan and tilt cover, do the following:

1. Properly position the cover and slide it into place. The sides of the cover must fit under the front and back rain guards of the pan and tilt, and the top of the cover must seat against the lip of the top gasket.
2. Apply pressure and push the top of the cover down to align the fastener holes.
3. Insert the Phillips head screw and tighten. Tighten until the screw will not turn.

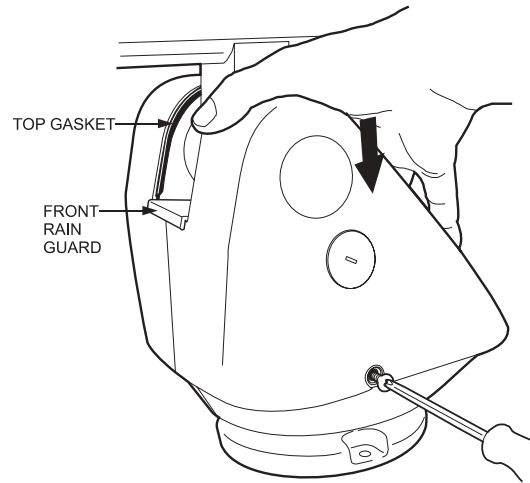

Figure 9. Pan and Tilt Cover Reinstallation

OPERATION

POWER-UP DISPLAY

When the Esprit system is powered up or reset, the selected protocol, revision number, and other information is displayed on the monitor. The information remains on the monitor until the system is moved.

PAN AND TILT OPERATION

Operation	How to Control
Pan and Tilt	Move joystick left/right and up/down.
Scanning	
Stop Scan	Call preset 96.
Random Scan	Call preset 97.
Frame Scan	Call preset 98.
Auto Scan	Call preset 99.
Presets	Refer to the documentation supplied with the controller.
Patterns	Refer to the documentation supplied with the controller.
Zones	Refer to the Programming section and to the documentation supplied with the controller.

For more information refer to *Operating Notes*.

CAMERA OPERATION (POD 100 THERMAL IMAGER)

For detailed information on camera operation, refer to the manual supplied with the POD 100 thermal imager or contact Industrial Security Alliance Partners, Inc. at (619) 232-7041.

Menu Item	Setting	ISAP Function
Polarity	WHT HOT (default)	Sets polarity so that normal white indicates hot.
Polarity	BLK HOT	Sets polarity so that inverted black indicates hot.
Auto Cal	Auto (default)	Turns on auto calibration.
Auto Cal	Off	Turns off auto calibration.
Man Cal		Forces a 1-point calibration.
Reset Camera		Resets Polarity, Auto Cal, AGC Mode, ROI, and Color Bar to their default settings.
AGC Mode	Auto (default)	Sets AGC Mode to On. (IRIS OPEN and IRIS CLOSE will override AGC Mode until the unit is panned or tilted approximately 15 degrees.)
AGC Mode	Off	Turns AGC Off.
Gain	Numeric value	Sets the gain value for the ISAP camera; AGC mode is turned Off. (After setting a value, the value will be updated with the closest threshold setting that changes the video image.)
Offset	Numeric value	Sets the offset value for the ISAP camera; AGC mode is turned Off.
ROI (Region of Interest)	All (default)	Sets ROI to full screen.
ROI (Region of Interest)	3/4	Sets ROI to the center 3/4 of the screen.
ROI (Region of Interest)	1/2	Sets ROI to the center 1/2 of the screen.
ROI (Region of Interest)	Center	Sets ROI to the center 1/4 of the screen.
Color Bar	On	Turns on color bars.
Color Bar	Off (default)	Turns off color bars.
Cam Ver		Displays Camera Version numbers.

OPERATING NOTES

ENVIRONMENTAL RANGE

The operating temperature ranges from a minimum of -40°F (-40°C) to a maximum of 122°F (50°C) for sustained system operation or 140°F (60°C) absolute maximum.

PAN AND TILT FUNCTIONS

Controller Type	Pan (Capability, 360° Continuous Pan Rotation)**	Tilt (Viewing Range, +33° to -83°)***
Fixed speed	Speed determined by controller	Speed determined by controller
Variable speed*	0.5 to 40° per second, depending on joystick position	0.5 to 20° per second, depending on joystick position
Turbo Mode*	100° per second	Does not affect the tilt speed
Preset Mode*	100° per second	30° per second

* 50 mph wind speed profile.

** If manual limit stops are set, "Pan Limit" appears on your monitor when a limit stop is reached. This does not apply to scan limit stops.

*** When the system reaches the upper limit, "Tilt Limit" appears on your monitor.

PAN, SCAN, AND TILT SPEEDS

Pan and scan speeds are adjustable from 3 to 40 degrees per second through the programming menu. The tilt speed is one-half of the pan speed.

NOTE: If a preset is set when the system is at the upper tilt limit, the preset label will be overridden by the label "Tilt Limit." The preset labels feature will not function.

LENS FUNCTIONS

Focus and iris functions are operated from the controller.

PRESET FUNCTIONS

The Esprit system is capable of going to 64 preset locations, each with a 20-character label. The presets are numbered 1-32 and 35-66. Refer to the documentation for your control system for programming presets.

If you command the pan and tilt to go to an undefined preset, erratic operation may result.

Presets 33 and 34 are fixed commands, meaning that you cannot program them. Preset 33 is the "flip" command, which pans the system 180 degrees. Preset 34 is the "pan zero" command, which pans the system to the factory-determined zero reference point.

RANDOM, FRAME, AND AUTO SCANNING

Select preset 97 (30) to start random scanning. Select preset 98 (31) to activate frame scanning (three seconds of scanning followed by a three-second pause). Select preset 99 (32) to start auto (continuous) scanning. Scan limit stops are controlled by software. Refer to the *Limit Stops* section to program the scan limit stops.

When the system reaches a scan limit stop, it reverses direction. Select preset 96 (29) to stop a scan. Any pan and tilt or lens command also will stop a scan.

NOTE: For AMERICAN DYNAMICS controllers with only 32 presets, set switch SW1-5 on the PCB in the ON position. When SW1-5 is ON, preset 99 becomes 32
98 becomes 31
97 becomes 30
96 becomes 29
95 becomes 28
93 becomes 26
92 becomes 25
91 becomes 24
90 becomes 23

If the limit stops are turned off (refer to the *Limit Stops* section), presets 23-26 can be used as regular presets.

ZONES

A zone is a programmed pan area with set boundaries and identifying label. The Esprit system has a maximum of eight zones, each with a 20-character label. Zones can be programmed to blank video when the camera pans into the zone area. If zone labels are turned off, the system displays the message, VIDEO BLANK, to indicate the video is blanked and not failing. (Refer to the *Zone Blank* section for instructions.)

PATTERNS

The Esprit system can do either one full pattern (1.5, 3, or 6 minutes long) or two half patterns (.75, 1.5, or 3 minutes long). This pattern can consist of any standard pan and tilt command. Presets, flip, and turbo are not allowed in a pattern. Zones can be enabled while running a pattern. Refer to the documentation for your control system to program and run patterns.

PARK

If the Esprit system does not receive any commands for a specified period of time (refer to the *Park Time Minutes* section), the system will go to preset 1 and park. If the time specified is zero, or if preset 1 has not been programmed, the system will not park.

QUICK START GUIDE – SYSTEM SETUP

PROGRAMMING GUIDE – ES30-ISAP PAN AND AND TILT SYSTEM

1. Access main menu (preset 95).
2. Make main menu selections.
 - Joystick: Move up or down to position cursor or to toggle between selections.
 - Iris Open: Enter.
 - Iris Close: Cancel.

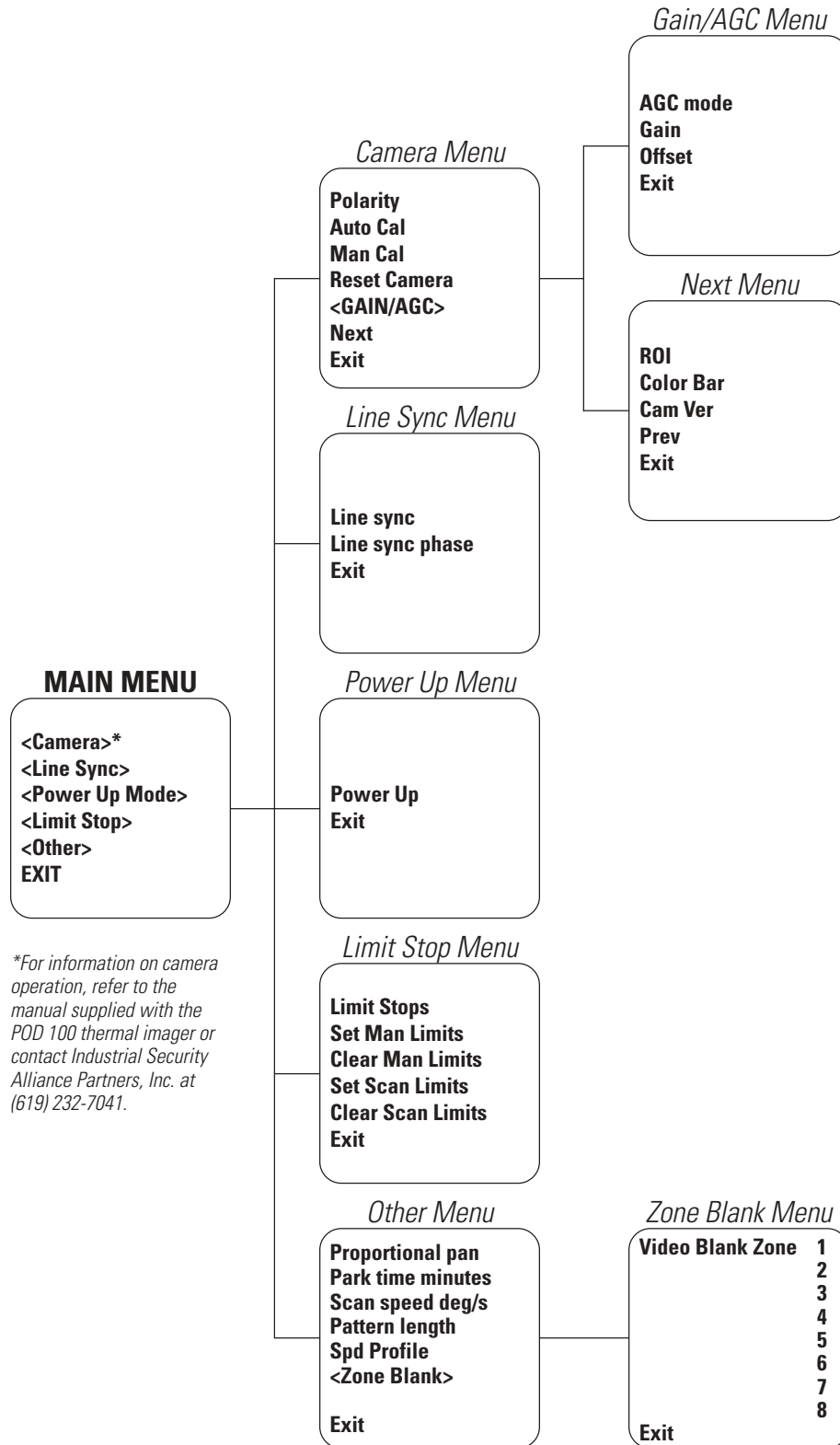

*For information on camera operation, refer to the manual supplied with the POD 100 thermal imager or contact Industrial Security Alliance Partners, Inc. at (619) 232-7041.

PRESETS

The following presets are reserved for special functions:

Preset	Function
1	Park
33	Flip command
34	Pan zero command
89	Toggle Polarity
90-91	Manual Limit stops
92-93	Auto Limit stops
95	Access Main Menu
96	Stop a scan
97	Random Scanning
98	Frame Scanning
99	Start Auto Scanning

NOTE: For AMERICAN DYNAMICS controllers with only 32 presets, set switch SW1-5 on the PCB in the ON position. When SW1-5 is ON, preset 99 becomes 32
 98 becomes 31
 97 becomes 30
 96 becomes 29
 95 becomes 28
 93 becomes 26
 92 becomes 25
 91 becomes 24
 90 becomes 23

If the limit stops are turned off (refer to the *Limit Stops* section), presets 23-26 can be used as regular presets.

NOTE: In the operation and programming instructions, sometimes a number in parentheses follows a preset. This second number is for 32-preset mode.

HOW TO ACCESS THE MAIN MENU (PRESET 95)

You can call up the main menu on your monitor by programming (setting or creating) preset 95 (preset 28 if in AD32-preset mode).

Programming preset 95 for Pelco's controllers varies according to the type of controller you are using. Instructions for programming preset 95 are given below for various Pelco controllers.

CM6700/CM6800

1. Enter the number of the Esprit system and press the CAM key.
2. Enter 95 and hold the PRESET key for two seconds.
3. In the Edit Preset menu, arrow to SET and press the ACK key. The main menu appears.

KBD200A/KBD300A (DIRECT MODE ONLY)

1. Enter 95.
2. Hold the PRESET key (approximately two seconds) until the main menu appears on the screen.

CM9500

1. Enter the number of the Esprit system and press the CAM key. The Main menu appears.
2. Highlight SETUP in the Main menu and press the SELECT key.
3. Highlight CAM in the Setup menu and press the SELECT key.
4. Highlight PRESET in the Camera menu and press the SELECT key.
5. Enter 95 and press the F1 key. The main menu appears.

CM9740/CM9760

1. Press the ESCAPE key to open the Main menu. Select DEF. The Define Submenu appears.
2. Enter your four-digit PIN if this is your first time entering this mode.
3. Enter 95 and select PRST. The main menu appears on the monitor.
4. Select the Quit icon to return to the default menu.

KBD4000/KBD4002 (GENEX® MULTIPLEXER)

1. Press the SPOT MONITOR key.
2. Enter 95, then hold the PRESET key (approximately two seconds) until the main menu appears on the screen.

MPT9500

Standard Coaxitron Mode

1. Enter 95 and press the PRESET SET key.
2. Position the asterisk in the YES row and press the F1 key. The main menu appears.

EXTENDED COAXITRON OR RS-485 MODE

1. Enter 95 and press the PRESET SET key.
2. Press the F2 key. The main menu appears.

PELCONET™

1. Check the Set box.
2. Click the preset 95 button. The main menu appears.

CAMERA

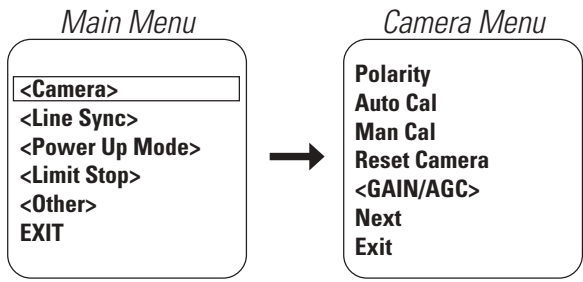

For information on camera operation, refer to the manual supplied with the POD 100 thermal imager or contact Industrial Security Alliance Partners, Inc. at (619) 232-7041.

LIMIT STOPS

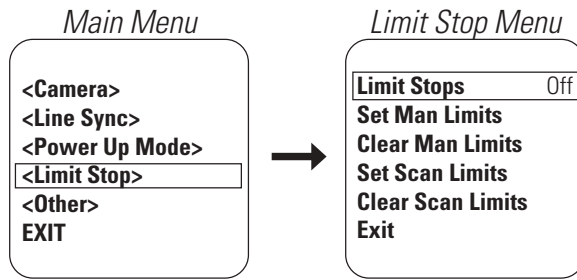

TURNING LIMIT STOPS ON OR OFF

To change the limit stop mode:

1. Program preset 95 (28). The main menu appears.
2. Position the cursor (>) beside Limit Stop.
3. Press the Iris Open button to enter the Limit Stop menu.
4. Position the cursor (>) beside Limit Stops.
5. Press the Iris Open button. The cursor moves to the right, beside the word On or Off.
6. Move the joystick up or down to toggle between On and Off.
7. SELECT – Press the Iris Open button on your keyboard to select your choice.
CANCEL – Press the Iris Close button if you do not want to change the setting.

PROGRAMMING LIMIT STOPS

Manual Limit Stops

When manual limit stops are set, a (joystick/pan and tilt keys) pan operation stops when a limit stop is reached. The manual limit stops can be set in one of two ways:

At the controller by programming presets 90 (23) and 91 (24)

or

At the controller by programming the Limit Stop menu

Presets

Refer to the documentation for your control system for programming presets, then do the following:

1. Make sure limit stops are turned ON, and then exit the menu.
2. Push the joystick left until you reach the limit you want the camera to go to on the left.
3. Program preset 90 (23).
4. Push the joystick right to the limit you want the camera to go to on the right.
5. Program preset 91 (24).

Setting presets 90 (23) and 91 (24) to the same point disables manual limit stops.

Limit Stops Menu

The manual pan limit stops can be set at the controller using the Limit Stop menu:

1. Program preset 95 (28). The main menu appears.
2. Position the cursor (>) beside Limit Stop.
3. Press the Iris Open button to enter the Limit Stop menu.
4. Move the cursor to Set Man Limits, and press the Iris Open button. PRESS IRIS OPEN TO SET LEFT LIMIT appears.
5. Move the pan and tilt to the desired left limit position, and press the Iris Open button to set the left manual limit. PRESS IRIS OPEN TO SET RIGHT LIMIT appears.
6. Move the pan and tilt to the desired right limit position, and press the Iris Open button to set the right manual limit.
7. Exit the Limit Stop menu.

Clear Manual Stops

To clear the manual limit stops:

1. Program preset 95 (28). The main menu appears.
2. Position the cursor (>) beside Limit Stop.
3. Press the Iris Open button to enter the Limit Stop menu.
4. Move the cursor to Clear Man Limits, and press the Iris Open button. The cursor will flash to an asterisk (*) briefly to indicate the limits have been disabled.

SCAN LIMIT STOPS

When scan limit stops are set, the pan and tilt reverses direction during random, frame, or auto scanning when a limit stop is reached. The manual scan limit stops can be set in one of two ways:

At the controller by programming presets 92 and 93

or

At the controller by programming the Limit Stop menu:

Presets

Refer to the documentation for your control system for programming presets, then do the following:

1. Make sure limit stops are turned ON, and then exit the menu.
2. Push the joystick left until you reach the limit you want the camera to go to on the left.
3. Program preset 92 (25).
4. Push the joystick right to the limit you want the camera to go to on the right.
5. Program preset 93 (26).

Setting presets 92 (25) and 93 (26) to the same point disables manual limit stops.

NOTE: Programming preset 92 (25) disables the scan limit stops until preset 93 (26) is set. Preset 92 is the left scan limit and preset 93 is the right scan limit.

Limit Stops Menu

The manual pan limit stops can be set at the controller using the Limit Stop menu:

1. Program preset 95 (28). The main menu appears.
2. Position the cursor (>) beside Limit Stop.
3. Press the Iris Open button to enter the Limit Stop menu.
4. Move the cursor to Set Scan Limits, and press the Iris Open button. PRESS IRIS OPEN TO SET LEFT LIMIT appears.
5. Move the pan and tilt to the desired left limit position, and press the Iris Open button to set the left manual limit. PRESS IRIS OPEN TO SET RIGHT LIMIT appears.
6. Move the pan and tilt to the desired right limit position, and press the Iris Open button to set the right scan limit.
7. Exit the Limit Stop menu.

Clear Scan Limit Stops

To clear the scan limit stops, move the cursor to Clear Scan Limits and press the Iris Open button. The cursor will flash to an asterisk (*) briefly to indicate the limits have been disabled.

LINE SYNCHRONIZATION

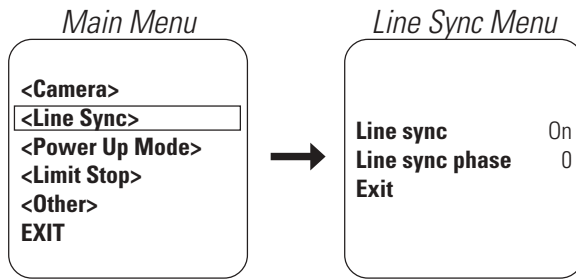

If cameras are out of phase with each other, they may produce what appears to be vertical roll when switching between cameras.

There are two settings for line synchronization:

ON – Adjust the synchronization of the power line voltage so that it is in phase with other cameras.

OFF – The system synchronizes to an internal clock.

To change the line synchronization settings:

1. Program preset 95 (28). The main menu appears.
2. Position the cursor (>) beside Line Sync.
3. Press the Iris Open button. The Line Sync menu appears.
4. Position the cursor (>) beside one of the choices. Press the Iris Open button.

LINE SYNC – The cursor moves to one of two choices: ON or OFF. Move the joystick up or down to toggle between them. Press the Iris Open button to select the choice. If you changed to OFF, the camera may reset itself as it adjusts to the new synchronization. If the camera resets, it will only affect the line synchronization. It will not change any other camera parameters, such as auto focus or auto iris. Press the Iris Close button if you do not want to change the setting.

LINE SYNC PHASE – The cursor moves to a numeric value. Move the joystick up or down to change the value. The value represents the phase angle in tenths of a degree between 0 and 359 degrees. For example, 900 is 90 degrees, 1200 is 120 degrees, and 2400 is 240 degrees. Press the Iris Open button on your keyboard to select your choice. The Line Sync setting changes to ON. The camera may reset or the picture on your monitor may wiggle when you change the phase angle. If the camera resets, it will only affect the line synchronization. It will not change any other camera parameters, such as auto focus or auto iris. Press the Iris Close button if you do not want to change the setting.

PARK TIME MINUTES

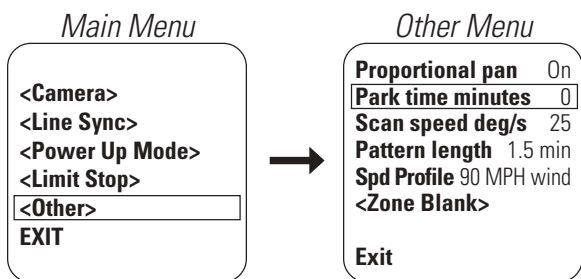

This feature causes the system to park at preset 1 after a programmed number of minutes of control inactivity. The time can be set from 1 minute to 720 minutes (12 hours), or it can be set to zero, which disables this feature.

To change the park time:

1. Program preset 95 (28). The main menu appears.
2. Position the cursor (>) beside Other.
3. Press the Iris Open button to enter the Other menu.
4. Position the cursor (>) beside Park Time Minutes.
5. Press the Iris Open button. The cursor moves to the right, beside the current park time.
6. Move the joystick up or down to change the park time.
7. SELECT – Press the Iris Open button on your keyboard to select your choice.
CANCEL – Press the Iris Close button if you do not want to change the setting.

NOTE: Preset 1 must be programmed for the system to park.

PATTERN LENGTH

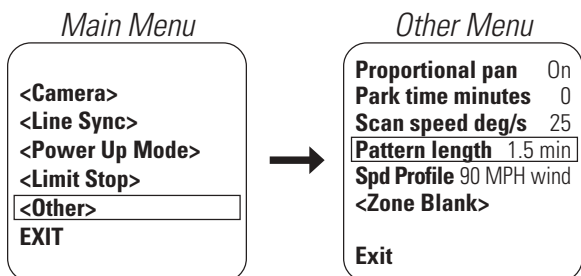

The ESPRIT can do the following:

One full pattern – 1.5, 3, or 6 minutes long

or

Two half patterns – .75, 1.5, or 3 minutes long

This pattern can consist of any standard pan and tilt command. Presets, flip, and turbo are not allowed in a pattern. Zone scan can be enabled while running a pattern.

To set the pattern length:

1. Program preset 95 (28). The main menu appears.
2. Position the cursor (>) beside Other.
3. Press the Iris Open button to enter the menu entitled Other.
4. Position the cursor (>) beside Pattern Length.
5. Press the Iris Open button. The cursor moves to the right, beside the number of minutes (1.5, 3, or 6).
6. Move the joystick up or down to toggle through the number of minutes (1.5, 3, or 6).
7. SELECT – Press the Iris Open button on your keyboard to select your choice.
CANCEL – Press the Iris Close button if you do not want to change the setting.

CAUTION: If the length is changed, all patterns that were stored are erased.

POWER-UP MODE

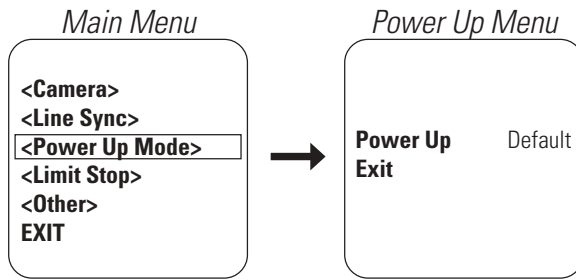

This feature lets the system resume a desired condition following power-up. The menu includes the following choices.

- Default – On power-up, the system goes through a configuration cycle and stops at zero reference, showing “Configuration Done,” address, and mode settings on the screen.
- Park – The system moves to preset 1 when the power-up sequence finishes. The only text on the screen is the preset label (if any is programmed).
- Scan Auto – The system initiates scan mode when the power-up sequence finishes. Again, there is no text.
- Scan Frame – The system initiates a frame scan when the power-up sequence finishes.
- Scan Rand – The system initiates a random scan when the power-up sequence finishes.
- Full Pat – The system initiates its programmed pattern when the power-up sequence finishes. The length can be set to 1.5, 3, or 6 minutes.
- Half Pat 1 – The system initiates the first half-pattern when the power-up sequence finishes. The length can be set to .75, 1.5, or 3 minutes.
- Half Pat 2 – The system initiates the second half-pattern when the power-up sequence finishes. The length can be set to .75, 1.5, or 3 minutes.

The default setting is Default.

To select the power-up mode:

1. Program preset 95 (28). The main menu appears.
2. Position the cursor (>) beside Power Up.
3. Press the Iris Open button to enter the Power Up menu.
4. Press the Iris Open button to move the cursor to the right.
5. Move the joystick up or down to cycle through the selections. Stop on the item you want to select.
6. SELECT – Press the Iris Open button on your keyboard to select your choice.
CANCEL – Press the Iris Close button if you do not want to change the setting.

PROPORTIONAL PAN

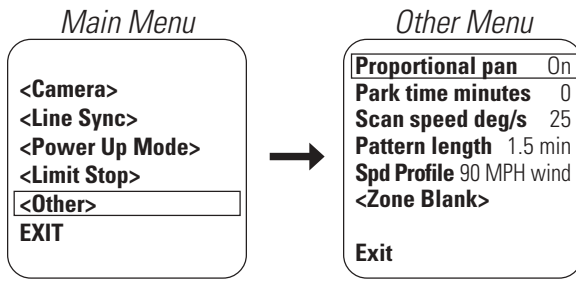

Proportional pan does not function with this version of Esprit.

SCAN SPEED

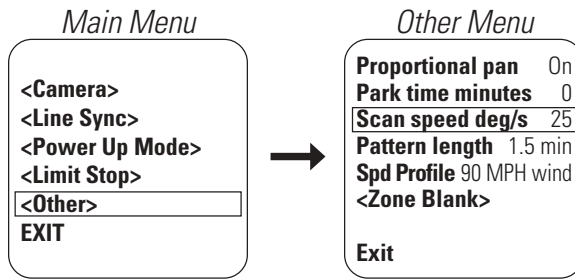

The scan speed is adjustable from 1-40 degrees per second. This occurs in three scan modes: auto, random, and frame scan.

To change the scan speed:

1. Program preset 95 (28). The main menu appears.
2. Position the cursor (>) beside Other.
3. Press the Iris Open button to enter the menu entitled Other.
4. Position the cursor (>) beside Scan Speed deg/s.
5. Press the Iris Open button. The cursor moves to the right, beside the number of degrees.
6. Move the joystick up or down to toggle through the number of degrees (1-40) until you reach the number you want. (If set on a low number, the scan will appear to barely move but is still functioning.)
7. SELECT – Press the Iris Open button on your keyboard to select your choice.
CANCEL – Press the Iris Close button if you do not want to change the setting.

SPEED PROFILE

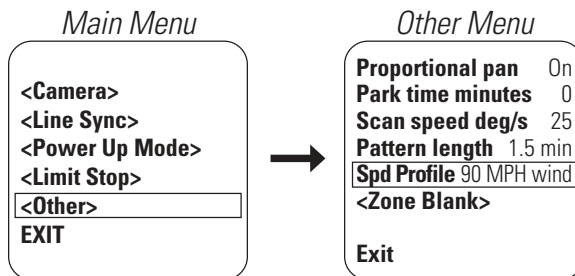

This feature allows the operator to set the wind speed conditions for the location of the Esprit system. You can set two wind speed profiles of 50 mph or 90 mph in which the system will remain operational. In both settings, the pan speed will be a maximum of 40 degrees per second. The difference will be in the turbo and preset pan speeds. The turbo and preset pan speeds are 100 degrees per second in the 50 mph wind profile setting and 50 degrees per second in the 90 mph profile.

To set the speed profile:

1. Program preset 95 (28). The main menu appears.
2. Position the cursor (>) beside Other.
3. Press the Iris Open button to enter the menu entitled Other.
4. Position the cursor (>) beside Spd Profile.
5. Press the Iris Open button. The cursor moves to the right, beside the wind speed (50 mph wind or 90 mph wind).
6. Move the joystick up or down to toggle between the wind speeds (50 mph wind or 90 mph wind).
7. SELECT – Press the Iris Open button on your keyboard to select your choice.
CANCEL – Press the Iris Close button if you do not want to change the setting.

ZONES

Basic rules for setting zones:

1. Refer to the documentation for your control system to program zones.
2. Establish zones using the controller, prior to programming ZONE BLANK with the Esprit on-screen menu.
3. To accurately set zone areas, zoom wide to the maximum field of view.
4. Set zones moving the joystick left to right. The left position is always the start position.

ZONE BLANK

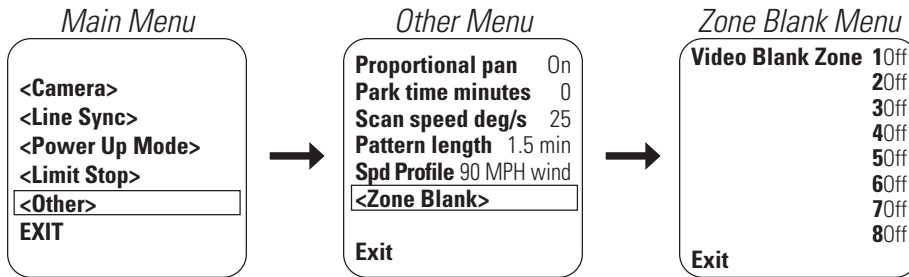

The Esprit system features on-screen programmable zone blanking. This feature lets you define any zone as blanked for video (viewing/recording).

Zones can be programmed to overlap each other, although this is not recommended. If you program two zones to overlap, the title of the zone with the highest priority (zone 8 is the highest, zone 1 is the lowest) will be displayed on the monitor. This rule also applies to blanked zones that overlap. The blanking status of the zone with the highest priority will determine if the area is blanked or not. Example: Zone 1 is blanked but a portion of the zone overlaps zone 8 which is not blanked. The overlapped portion of zone 1 will be displayed on the monitor with the zone 8 label.

There are two video zone blank settings:

On – Enables video blanking.

Off – Disables video blanking.

To change the video blank zone setting:

1. Program preset 95 (28). The main menu appears.
2. Position the cursor (>) beside Other.
3. Press the Iris Open button to enter the Other menu.
4. Position the cursor (>) beside Zone Blank.
5. Press the Iris Open button to enter the Zone Blank menu.
6. Position the cursor (>) beside the number of the zone for which you want to set the blank option.
7. Press the Iris Open button. The cursor moves to the right, beside the word On or Off.
8. Move the joystick up or down to toggle between the words On and Off.
9. SELECT – Press the Iris Open button on your keyboard to select your choice.
CANCEL – Press the Iris Close button if you do not want to change the setting.

PRODUCT SUPPORT

ES30-ISAP PAN AND TILT SYSTEM CONTACT:

Pelco
3500 Pelco Way
Clovis, CA 93612 USA
Tel: 800/289-9100 (USA & Canada)
1-559/292-1981 (International)
www.pelco.com

POD 100 THERMAL IMAGER (CAMERA) CONTACT:

Industrial Security Alliance Partners, Inc.
1495 Pacifica Highway, Suite 350
San Diego, CA 92101
Tel: 619-232-7041
www.isapusa.com

APPENDIX

NOTE: Esprit will sense and automatically select input from Coaxitron control signals in either the standard or extended mode. Therefore, the DIP switch settings have no effect on Coaxitron control signals.

Table A. Switch Settings for SW1

Baud Rate	Switch Setting		
	SW1-1	SW1-2	SW1-3
2400	OFF	OFF	OFF*
4800	ON	OFF	OFF*
9600	OFF	ON	OFF*

*SW1-3 is not used; set it in the OFF position.

Switch Setting				
SW1-4	SW1-5	SW1-6	SW1-7	SW1-8
OFF*	Note (1)	Note (2)	Note (3)	Note (4)
NOTES:				
(1) SW1-5	OFF	- For controllers that have more than 32 presets.		
	ON	- For American Dynamics controllers (32 presets).		
(2) SW1-6	OFF	- For all control systems except CM9502 with variable speed keyboards. For CM9502 with fixed speed keyboards, set switch OFF.		
	ON	- For CM9502 with variable speed keyboards to get smoother joystick control.		
(3) SW1-7	OFF	- RS-422 transmitter is not terminated.		
	ON	- RS-422 transmitter is terminated.		
(4) SW1-8	OFF	- RS-422 receiver is not terminated.		
	ON	- RS-422 receiver is terminated.		

*SW1-4 is not used; set it in the OFF position.

Table B. Switch Settings for SW2

Receiver Address		Switch Setting							
P-Type	D-Type	SW2-1	SW2-2	SW2-3	SW2-4	SW2-5	SW2-6	SW2-7	SW2-8
Control	Control								
1	-	OFF	OFF	OFF	OFF	OFF	OFF	OFF	OFF
2	1	ON	OFF	OFF	OFF	OFF	OFF	OFF	OFF
3	2	OFF	ON	OFF	OFF	OFF	OFF	OFF	OFF
4	3	ON	ON	OFF	OFF	OFF	OFF	OFF	OFF
5	4	OFF	OFF	ON	OFF	OFF	OFF	OFF	OFF
6	5	ON	OFF	ON	OFF	OFF	OFF	OFF	OFF
7	6	OFF	ON	ON	OFF	OFF	OFF	OFF	OFF
8	7	ON	ON	ON	OFF	OFF	OFF	OFF	OFF
9	8	OFF	OFF	OFF	ON	OFF	OFF	OFF	OFF
10	9	ON	OFF	OFF	ON	OFF	OFF	OFF	OFF
11	10	OFF	ON	OFF	ON	OFF	OFF	OFF	OFF
12	11	ON	ON	OFF	ON	OFF	OFF	OFF	OFF
13	12	OFF	OFF	ON	ON	OFF	OFF	OFF	OFF
14	13	ON	OFF	ON	ON	OFF	OFF	OFF	OFF
15	14	OFF	ON	ON	ON	OFF	OFF	OFF	OFF
16	15	ON	ON	ON	ON	OFF	OFF	OFF	OFF
17	16	OFF	OFF	OFF	OFF	ON	OFF	OFF	OFF
18	17	ON	OFF	OFF	OFF	ON	OFF	OFF	OFF
19	18	OFF	ON	OFF	OFF	ON	OFF	OFF	OFF
20	19	ON	ON	OFF	OFF	ON	OFF	OFF	OFF
21	20	OFF	OFF	ON	OFF	ON	OFF	OFF	OFF
22	21	ON	OFF	ON	OFF	ON	OFF	OFF	OFF
23	22	OFF	ON	ON	OFF	ON	OFF	OFF	OFF
24	23	ON	ON	ON	OFF	ON	OFF	OFF	OFF
25	24	OFF	OFF	OFF	ON	ON	OFF	OFF	OFF
26	25	ON	OFF	OFF	ON	ON	OFF	OFF	OFF
27	26	OFF	ON	OFF	ON	ON	OFF	OFF	OFF
28	27	ON	ON	OFF	ON	ON	OFF	OFF	OFF
29	28	OFF	OFF	ON	ON	ON	OFF	OFF	OFF
30	29	ON	OFF	ON	ON	ON	OFF	OFF	OFF
31	30	OFF	ON	ON	ON	ON	OFF	OFF	OFF
32	31	ON	ON	ON	ON	ON	OFF	OFF	OFF
-	32	OFF	OFF	OFF	OFF	OFF	ON	OFF	OFF
-	33	ON	OFF	OFF	OFF	OFF	ON	OFF	OFF
-	34	OFF	ON	OFF	OFF	OFF	ON	OFF	OFF
-	35	ON	ON	OFF	OFF	OFF	ON	OFF	OFF
-	36	OFF	OFF	ON	OFF	OFF	ON	OFF	OFF
-	37	ON	OFF	ON	OFF	OFF	ON	OFF	OFF
-	38	OFF	ON	ON	OFF	OFF	ON	OFF	OFF
-	39	ON	ON	ON	OFF	OFF	ON	OFF	OFF
-	40	OFF	OFF	OFF	ON	OFF	ON	OFF	OFF
-	41	ON	OFF	OFF	ON	OFF	ON	OFF	OFF
-	42	OFF	ON	OFF	ON	OFF	ON	OFF	OFF
-	43	ON	ON	OFF	ON	OFF	ON	OFF	OFF
-	44	OFF	OFF	ON	ON	OFF	ON	OFF	OFF
-	45	ON	OFF	ON	ON	OFF	ON	OFF	OFF
-	46	OFF	ON	ON	ON	OFF	ON	OFF	OFF
-	47	ON	ON	ON	ON	OFF	ON	OFF	OFF
-	48	OFF	OFF	OFF	OFF	ON	ON	OFF	OFF
-	49	ON	OFF	OFF	OFF	ON	ON	OFF	OFF
-	50	OFF	ON	OFF	OFF	ON	ON	OFF	OFF
-	51	ON	ON	OFF	OFF	ON	ON	OFF	OFF
-	52	OFF	OFF	ON	OFF	ON	ON	OFF	OFF
-	53	ON	OFF	ON	OFF	ON	ON	OFF	OFF
-	54	OFF	ON	ON	OFF	ON	ON	OFF	OFF
-	55	ON	ON	ON	OFF	ON	ON	OFF	OFF

Receiver Address		Switch Setting							
P-Type	D-Type	SW2-1	SW2-2	SW2-3	SW2-4	SW2-5	SW2-6	SW2-7	SW2-8
Control	Control								
-	56	OFF	OFF	OFF	ON	ON	ON	OFF	OFF
-	57	ON	OFF	OFF	ON	ON	ON	OFF	OFF
-	58	OFF	ON	OFF	ON	ON	ON	OFF	OFF
-	59	ON	ON	OFF	ON	ON	ON	OFF	OFF
-	60	OFF	OFF	ON	ON	ON	ON	OFF	OFF
-	61	ON	OFF	ON	ON	ON	ON	OFF	OFF
-	62	OFF	ON	ON	ON	ON	ON	OFF	OFF
-	63	ON	ON	ON	ON	ON	ON	OFF	OFF
-	64	OFF	OFF	OFF	OFF	OFF	OFF	ON	OFF
-	65	ON	OFF	OFF	OFF	OFF	OFF	ON	OFF
-	66	OFF	ON	OFF	OFF	OFF	OFF	ON	OFF
-	67	ON	ON	OFF	OFF	OFF	OFF	ON	OFF
-	68	OFF	OFF	ON	OFF	OFF	OFF	ON	OFF
-	69	ON	OFF	ON	OFF	OFF	OFF	ON	OFF
-	70	OFF	ON	ON	OFF	OFF	OFF	ON	OFF
-	71	ON	ON	ON	OFF	OFF	OFF	ON	OFF
-	72	OFF	OFF	OFF	ON	OFF	OFF	ON	OFF
-	73	ON	OFF	OFF	ON	OFF	OFF	ON	OFF
-	74	OFF	ON	OFF	ON	OFF	OFF	ON	OFF
-	75	ON	ON	OFF	ON	OFF	OFF	ON	OFF
-	76	OFF	OFF	ON	ON	OFF	OFF	ON	OFF
-	77	ON	OFF	ON	ON	OFF	OFF	ON	OFF
-	78	OFF	ON	ON	ON	OFF	OFF	ON	OFF
-	79	ON	ON	ON	ON	OFF	OFF	ON	OFF
-	80	OFF	OFF	OFF	OFF	ON	OFF	ON	OFF
-	81	ON	OFF	OFF	OFF	ON	OFF	ON	OFF
-	82	OFF	ON	OFF	OFF	ON	OFF	ON	OFF
-	83	ON	ON	OFF	OFF	ON	OFF	ON	OFF
-	84	OFF	OFF	ON	OFF	ON	OFF	ON	OFF
-	85	ON	OFF	ON	OFF	ON	OFF	ON	OFF
-	86	OFF	ON	ON	OFF	ON	OFF	ON	OFF
-	87	ON	ON	ON	OFF	ON	OFF	ON	OFF
-	88	OFF	OFF	OFF	ON	ON	OFF	ON	OFF
-	89	ON	OFF	OFF	ON	ON	OFF	ON	OFF
-	90	OFF	ON	OFF	ON	ON	OFF	ON	OFF
-	91	ON	ON	OFF	ON	ON	OFF	ON	OFF
-	92	OFF	OFF	ON	ON	ON	OFF	ON	OFF
-	93	ON	OFF	ON	ON	ON	OFF	ON	OFF
-	94	OFF	ON	ON	ON	ON	OFF	ON	OFF
-	95	ON	ON	ON	ON	ON	OFF	ON	OFF
-	96	OFF	OFF	OFF	OFF	OFF	ON	ON	OFF
-	97	ON	OFF	OFF	OFF	OFF	ON	ON	OFF
-	98	OFF	ON	OFF	OFF	OFF	ON	ON	OFF
-	99	ON	ON	OFF	OFF	OFF	ON	ON	OFF
-	100	OFF	OFF	ON	OFF	OFF	ON	ON	OFF
-	101	ON	OFF	ON	OFF	OFF	ON	ON	OFF
-	102	OFF	ON	ON	OFF	OFF	ON	ON	OFF
-	103	ON	ON	ON	OFF	OFF	ON	ON	OFF
-	104	OFF	OFF	OFF	ON	OFF	ON	ON	OFF
-	105	ON	OFF	OFF	ON	OFF	ON	ON	OFF
-	106	OFF	ON	OFF	ON	OFF	ON	ON	OFF
-	107	ON	ON	OFF	ON	OFF	ON	ON	OFF
-	108	OFF	OFF	ON	ON	OFF	ON	ON	OFF
-	109	ON	OFF	ON	ON	OFF	ON	ON	OFF
-	110	OFF	ON	ON	ON	OFF	ON	ON	OFF
-	111	ON	ON	ON	ON	OFF	ON	ON	OFF

(Continued on next page)

Table B. Switch Settings for SW2 (Continued)

Receiver Address		Switch Setting							
P-Type	D-Type	SW2-1	SW2-2	SW2-3	SW2-4	SW2-5	SW2-6	SW2-7	SW2-8
Control	Control								
-	112	OFF	OFF	OFF	OFF	ON	ON	ON	OFF
-	113	ON	OFF	OFF	OFF	ON	ON	ON	OFF
-	114	OFF	ON	OFF	OFF	ON	ON	ON	OFF
-	115	ON	ON	OFF	OFF	ON	ON	ON	OFF
-	116	OFF	OFF	ON	OFF	ON	ON	ON	OFF
-	117	ON	OFF	ON	OFF	ON	ON	ON	OFF
-	118	OFF	ON	ON	OFF	ON	ON	ON	OFF
-	119	ON	ON	ON	OFF	ON	ON	ON	OFF
-	120	OFF	OFF	OFF	ON	ON	ON	ON	OFF
-	121	ON	OFF	OFF	ON	ON	ON	ON	OFF
-	122	OFF	ON	OFF	ON	ON	ON	ON	OFF
-	123	ON	ON	OFF	ON	ON	ON	ON	OFF
-	124	OFF	OFF	ON	ON	ON	ON	ON	OFF
-	125	ON	OFF	ON	ON	ON	ON	ON	OFF
-	126	OFF	ON	ON	ON	ON	ON	ON	OFF
-	127	ON	ON	ON	ON	ON	ON	ON	OFF
-	128	OFF	OFF	OFF	OFF	OFF	OFF	OFF	ON
-	129	ON	OFF	OFF	OFF	OFF	OFF	OFF	ON
-	130	OFF	ON	OFF	OFF	OFF	OFF	OFF	ON
-	131	ON	ON	OFF	OFF	OFF	OFF	OFF	ON
-	132	OFF	OFF	ON	OFF	OFF	OFF	OFF	ON
-	133	ON	OFF	ON	OFF	OFF	OFF	OFF	ON
-	134	OFF	ON	ON	OFF	OFF	OFF	OFF	ON
-	135	ON	ON	ON	OFF	OFF	OFF	OFF	ON
-	136	OFF	OFF	OFF	ON	OFF	OFF	OFF	ON
-	137	ON	OFF	OFF	ON	OFF	OFF	OFF	ON
-	138	OFF	ON	OFF	ON	OFF	OFF	OFF	ON
-	139	ON	ON	OFF	ON	OFF	OFF	OFF	ON
-	140	OFF	OFF	ON	ON	OFF	OFF	OFF	ON
-	141	ON	OFF	ON	ON	OFF	OFF	OFF	ON
-	142	OFF	ON	ON	ON	OFF	OFF	OFF	ON
-	143	ON	ON	ON	ON	OFF	OFF	OFF	ON
-	144	OFF	OFF	OFF	OFF	ON	OFF	OFF	ON
-	145	ON	OFF	OFF	OFF	ON	OFF	OFF	ON
-	146	OFF	ON	OFF	OFF	ON	OFF	OFF	ON
-	147	ON	ON	OFF	OFF	ON	OFF	OFF	ON
-	148	OFF	OFF	ON	OFF	ON	OFF	OFF	ON
-	149	ON	OFF	ON	OFF	ON	OFF	OFF	ON
-	150	OFF	ON	ON	OFF	ON	OFF	OFF	ON
-	151	ON	ON	ON	OFF	ON	OFF	OFF	ON
-	152	OFF	OFF	OFF	ON	ON	OFF	OFF	ON
-	153	ON	OFF	OFF	ON	ON	OFF	OFF	ON
-	154	OFF	ON	OFF	ON	ON	OFF	OFF	ON
-	155	ON	ON	OFF	ON	ON	OFF	OFF	ON
-	156	OFF	OFF	ON	ON	ON	OFF	OFF	ON
-	157	ON	OFF	ON	ON	ON	OFF	OFF	ON
-	158	OFF	ON	ON	ON	ON	OFF	OFF	ON
-	159	ON	ON	ON	ON	ON	OFF	OFF	ON
-	160	OFF	OFF	OFF	OFF	OFF	ON	OFF	ON
-	161	ON	OFF	OFF	OFF	OFF	ON	OFF	ON
-	162	OFF	ON	OFF	OFF	OFF	ON	OFF	ON
-	163	ON	ON	OFF	OFF	OFF	ON	OFF	ON
-	164	OFF	OFF	ON	OFF	OFF	ON	OFF	ON
-	165	ON	OFF	ON	OFF	OFF	ON	OFF	ON
-	166	OFF	ON	ON	OFF	OFF	ON	OFF	ON
-	167	ON	ON	ON	OFF	OFF	ON	OFF	ON
-	168	OFF	OFF	OFF	ON	OFF	ON	OFF	ON
-	169	ON	OFF	OFF	ON	OFF	ON	OFF	ON
-	170	OFF	ON	OFF	ON	OFF	ON	OFF	ON
-	171	ON	ON	OFF	ON	OFF	ON	OFF	ON

Receiver Address		Switch Setting							
P-Type	D-Type	SW2-1	SW2-2	SW2-3	SW2-4	SW2-5	SW2-6	SW2-7	SW2-8
Control	Control								
-	172	OFF	OFF	ON	ON	OFF	ON	OFF	ON
-	173	ON	OFF	ON	ON	OFF	ON	OFF	ON
-	174	OFF	ON	ON	ON	OFF	ON	OFF	ON
-	175	ON	ON	ON	ON	OFF	ON	OFF	ON
-	176	OFF	OFF	OFF	OFF	ON	ON	OFF	ON
-	177	ON	OFF	OFF	OFF	ON	ON	OFF	ON
-	178	OFF	ON	OFF	OFF	ON	ON	OFF	ON
-	179	ON	ON	OFF	OFF	ON	ON	OFF	ON
-	180	OFF	OFF	ON	OFF	ON	ON	OFF	ON
-	181	ON	OFF	ON	OFF	ON	ON	OFF	ON
-	182	OFF	ON	ON	OFF	ON	ON	OFF	ON
-	183	ON	ON	ON	OFF	ON	ON	OFF	ON
-	184	OFF	OFF	OFF	ON	ON	ON	OFF	ON
-	185	ON	OFF	OFF	ON	ON	ON	OFF	ON
-	186	OFF	ON	OFF	ON	ON	ON	OFF	ON
-	187	ON	ON	OFF	ON	ON	ON	OFF	ON
-	188	OFF	OFF	ON	ON	ON	ON	OFF	ON
-	189	ON	OFF	ON	ON	ON	ON	OFF	ON
-	190	OFF	ON	ON	ON	ON	ON	OFF	ON
-	191	ON	ON	ON	ON	ON	ON	OFF	ON
-	192	OFF	OFF	OFF	OFF	OFF	OFF	ON	ON
-	193	ON	OFF	OFF	OFF	OFF	OFF	ON	ON
-	194	OFF	ON	OFF	OFF	OFF	OFF	ON	ON
-	195	ON	ON	OFF	OFF	OFF	OFF	ON	ON
-	196	OFF	OFF	ON	OFF	OFF	OFF	ON	ON
-	197	ON	OFF	ON	OFF	OFF	OFF	ON	ON
-	198	OFF	ON	ON	OFF	OFF	OFF	ON	ON
-	199	ON	ON	ON	OFF	OFF	OFF	ON	ON
-	200	OFF	OFF	OFF	ON	OFF	OFF	ON	ON
-	201	ON	OFF	OFF	ON	OFF	OFF	ON	ON
-	202	OFF	ON	OFF	ON	OFF	OFF	ON	ON
-	203	ON	ON	OFF	ON	OFF	OFF	ON	ON
-	204	OFF	OFF	ON	ON	OFF	OFF	ON	ON
-	205	ON	OFF	ON	ON	OFF	OFF	ON	ON
-	206	OFF	ON	ON	ON	OFF	OFF	ON	ON
-	207	ON	ON	ON	ON	OFF	OFF	ON	ON
-	208	OFF	OFF	OFF	OFF	ON	OFF	ON	ON
-	209	ON	OFF	OFF	OFF	ON	OFF	ON	ON
-	210	OFF	ON	OFF	OFF	ON	OFF	ON	ON
-	211	ON	ON	OFF	OFF	ON	OFF	ON	ON
-	212	OFF	OFF	ON	OFF	ON	OFF	ON	ON
-	213	ON	OFF	ON	OFF	ON	OFF	ON	ON
-	214	OFF	ON	ON	OFF	ON	OFF	ON	ON
-	215	ON	ON	ON	OFF	ON	OFF	ON	ON
-	216	OFF	OFF	OFF	ON	ON	OFF	ON	ON
-	217	ON	OFF	OFF	ON	ON	OFF	ON	ON
-	218	OFF	ON	OFF	ON	ON	OFF	ON	ON
-	219	ON	ON	OFF	ON	ON	OFF	ON	ON
-	220	OFF	OFF	ON	ON	ON	OFF	ON	ON
-	221	ON	OFF	ON	ON	ON	OFF	ON	ON
-	222	OFF	ON	ON	ON	ON	OFF	ON	ON
-	223	ON	ON	ON	ON	ON	OFF	ON	ON
-	224	OFF	OFF	OFF	OFF	OFF	ON	ON	ON
-	225	ON	OFF	OFF	OFF	OFF	ON	ON	ON
-	226	OFF	ON	OFF	OFF	OFF	ON	ON	ON
-	227	ON	ON	OFF	OFF	OFF	ON	ON	ON
-	228	OFF	OFF	ON	OFF	OFF	ON	ON	ON
-	229	ON	OFF	ON	OFF	OFF	ON	ON	ON
-	230	OFF	ON	ON	OFF	OFF	ON	ON	ON
-	231	ON	ON	ON	OFF	OFF	ON	ON	ON

(Continued on next page)

Table B. Switch Settings for SW2 (Continued)

Receiver Address		Switch Setting							
P-Type	D-Type	SW2-1	SW2-2	SW2-3	SW2-4	SW2-5	SW2-6	SW2-7	SW2-8
Control	Control								
-	232	OFF	OFF	OFF	ON	OFF	ON	ON	ON
-	233	ON	OFF	OFF	ON	OFF	ON	ON	ON
-	234	OFF	ON	OFF	ON	OFF	ON	ON	ON
-	235	ON	ON	OFF	ON	OFF	ON	ON	ON
-	236	OFF	OFF	ON	ON	OFF	ON	ON	ON
-	237	ON	OFF	ON	ON	OFF	ON	ON	ON
-	238	OFF	ON	ON	ON	OFF	ON	ON	ON
-	239	ON	ON	ON	ON	OFF	ON	ON	ON
-	240	OFF	OFF	OFF	OFF	ON	ON	ON	ON
-	241	ON	OFF	OFF	OFF	ON	ON	ON	ON
-	242	OFF	ON	OFF	OFF	ON	ON	ON	ON
-	243	ON	ON	OFF	OFF	ON	ON	ON	ON

Receiver Address		Switch Setting							
P-Type	D-Type	SW2-1	SW2-2	SW2-3	SW2-4	SW2-5	SW2-6	SW2-7	SW2-8
Control	Control								
-	244	OFF	OFF	ON	OFF	ON	ON	ON	ON
-	245	ON	OFF	ON	OFF	ON	ON	ON	ON
-	246	OFF	ON	ON	OFF	ON	ON	ON	ON
-	247	ON	ON	ON	OFF	ON	ON	ON	ON
-	248	OFF	OFF	OFF	ON	ON	ON	ON	ON
-	249	ON	OFF	OFF	ON	ON	ON	ON	ON
-	250	OFF	ON	OFF	ON	ON	ON	ON	ON
-	251	ON	ON	OFF	ON	ON	ON	ON	ON
-	252	OFF	OFF	ON	ON	ON	ON	ON	ON
-	253	ON	OFF	ON	ON	ON	ON	ON	ON
-	254	OFF	ON	ON	ON	ON	ON	ON	ON

SPECIFICATIONS (PAN AND TILT SYSTEM ONLY)

ELECTRICAL

Input Voltage:	24, 120, or 230 VAC, 50/60 Hz; switch selectable for 120/230 VAC inputs
Output Voltage for POD100:	12 VDC ($\pm 10\%$), with POD100 installed
Power Consumption:	Maximum 50 VA per system
Electrical Connections:	Two power source connections made at mount location with wire splices and one ground wire splice; one BNC receptacle and four wire splices at mount location for output of RS-422 D and P protocols

Video Coaxial Cable

Max. Wiring Distances:	Cable Type*	Maximum Distance
	RG59/U	750 ft (229 m)
	RG6/U	1,000 ft (305 m)
	RG11/U	1,500 ft (457 m)

* Minimum cable requirements:

- 75 ohms impedance
- All-copper center conductor
- All-copper braided shield with 95% braid coverage.

MECHANICAL

Pan Movement:	360° continuous pan rotation
Vertical Tilt:	Unobstructed +33° to -83°
Variable Pan/Tilt Speed	
	Pan: 0.5° to 40°/sec variable-speed operation, 100°/sec turbo
	Tilt: 0.5° to 20°/sec variable-speed operation
Preset Speeds	
	Pan: 100°/sec
	Tilt: 30°/sec

GENERAL

Construction:	Die-cast, extruded and sheet aluminum; stainless steel hardware
Finish:	Gray polyester powder coat
Operating Temperature:	-50° to 122°F (-45° to 50°C) for sustained pan and tilt system operation or 140°F (60°C) absolute maximum
Operating Environment:	Will remain operational in 90 mph wind conditions; withstands 130 mph
Weight (approx.)	
	With Pedestal Adapter 14 lb (6.35 kg)
	With Wall Mount 16 lb (7.26 kg)

REGULATORY NOTICES

This equipment has been tested and found to comply with the limits of a Class B digital device, pursuant to part 15 of the FCC rules. These limits are designed to provide reasonable protection against harmful interference in a residential installation. This equipment generates, uses, and can radiate radio frequency energy and, if not installed and used in accordance with the instructions, may cause harmful interference to radio communications. However there is no guarantee that the interference will not occur in a particular installation. If this equipment does cause harmful interference to radio or television reception, which can be determined by turning the equipment off and on, the user is encouraged to try and correct the interference by one or more of the following measures:

- Reorient or relocate the receiving antenna.
- Increase the separation between the equipment and the receiver.
- Connect the equipment into an outlet on a circuit different from that to which the receiver is connected.
- Consult the dealer or an experienced radio/TV technician for help.

WARRANTY AND RETURN INFORMATION

WARRANTY

Pelco will repair or replace, without charge, any merchandise proved defective in material or workmanship for a period of one year after the date of shipment. Exceptions to this warranty are as noted below.

- Five years on Pelco manufactured cameras (CC3500/CC3600/CC3700 and MC3500/MC3600 Series); two years on all other cameras.
- Three years on Genex® Series (multiplexers, server, and keyboard) and 090 Series Camclosure® Camera System.
- Two years on 100/150, 200 and 300 Series Camclosure® Camera Systems.
- Two years on cameras and all standard motorized or fixed focal length lenses.
- Two years on Legacy®, CM6700/CM6800/CM8500/CM9500/CM9740/CM9760 Matrix, DF5 and DF8 Series Fixed Dome products.
- Two years on Spectra®, Esprit®, and PS20 Scanners, including when used in continuous motion applications.
- Two years on Esprit and WW5700 series window wiper (excluding wiper blades).
- Eighteen months on DX Series digital video recorders.
- One year (except video heads) on video cassette recorders (VCRs). Video heads will be covered for a period of six months.
- Six months on all pan and tilts, scanners or preset lenses used in continuous motion applications (that is, preset scan, tour and auto scan modes).

Pelco will warrant all replacement parts and repairs for 90 days from the date of Pelco shipment. All goods requiring warranty repair shall be sent freight prepaid to Pelco, Clovis, California. Repairs made necessary by reason of misuse, alteration, normal wear, or accident are not covered under this warranty.

Pelco assumes no risk and shall be subject to no liability for damages or loss resulting from the specific use or application made of the Products. Pelco's liability for any claim, whether based on breach of contract, negligence, infringement of any rights of any party or product liability, relating to the Products shall not exceed the price paid by the Dealer to Pelco for such Products. In no event will Pelco be liable for any special, incidental or consequential damages (including loss of use, loss of profit and claims of third parties) however caused, whether by the negligence of Pelco or otherwise.

The above warranty provides the Dealer with specific legal rights. The Dealer may also have additional rights, which are subject to variation from state to state.

If a warranty repair is required, the Dealer must contact Pelco at (800) 289-9100 or (559) 292-1981 to obtain a Repair Authorization number (RA), and provide the following information:

1. Model and serial number
2. Date of shipment, P.O. number, Sales Order number, or Pelco invoice number
3. Details of the defect or problem

If there is a dispute regarding the warranty of a product which does not fall under the warranty conditions stated above, please include a written explanation with the product when returned.

Method of return shipment shall be the same or equal to the method by which the item was received by Pelco.

RETURNS

In order to expedite parts returned to the factory for repair or credit, please call the factory at (800) 289-9100 or (559) 292-1981 to obtain an authorization number (CA number if returned for credit, and RA number if returned for repair).

All merchandise returned for credit may be subject to a 20% restocking and refurbishing charge.

Goods returned for repair or credit should be clearly identified with the assigned CA or RA number and freight should be prepaid. Ship to the appropriate address below.

If you are located within the continental U.S., Alaska, Hawaii or Puerto Rico:

Service Department
Pelco
3500 Pelco Way
Clovis, CA 93612-5699

If you are located outside the continental U.S., Alaska, Hawaii or Puerto Rico:

Intermediate Consignee
American Overseas Air Freight
320 Beach Road
Burlingame, CA 94010
USA

Ultimate Consignee
Pelco
3500 Pelco Way
Clovis, CA 93612-5699
USA

REVISION HISTORY

Manual #	Date	Comments
C312M	11/02	Original version.
C312M-A	12/02	Added FCC Class B information.



World Headquarters
3500 Pelco Way
Clovis, California 93612 USA

USA & Canada
Tel: 800/289-9100
Fax: 800/289-9150

International
Tel: 1-559/292-1981
Fax: 1-559/348-1120

www.pelco.com

ISO9001

Orangeburg, New York | Las Vegas, Nevada | Eindhoven, The Netherlands | Wokingham, United Kingdom | Montreal, Canada