



LAN9131



High-Performance Network Multimedia Processing Engine, Featuring RipStream™ Technology

Industry's first high-performance, wired 10/100 network multimedia processing engine employing RipStream technology, which combines support for multiple high-definition (HD) streams, a software protocol stack management and security.

Highlights

- RipStream technology supporting DLNA guidelines
 - Supports multiple HD video streams
 - Built-in UPnP, HTTP, TCP/IP protocol stack
 - Integrated 128-bit AES encryption/decryption for Digital Rights Management (DRM)
 - Supports Windows® Media DRM10 (WMDRM 10)
 - Supports Digital Transmission Content Protection over Internet Protocol (DTCP-IP)
 - Fast DTCP-IP AKE key exchange time (0.6 sec.)
- Two Transport Stream Interfaces (TSIs) to MPEG encoder/decoder SoCs
 - Either interface can be used in server or rendering applications
- Video codec agnostic
 - Supports MPEG2, MPEG4, WMV9/VC-1, H.264/AVC
- Integrated ARM926™ core
- Integrated 10/100 MAC/PHY with HP Auto-MDIX support and multiple power management modes
- TCP/UDP checksum offload

Target Applications

- Ethernet-based Video/Media Distribution Systems
- Digital Video Recorders
- High-definition Televisions
- Video Servers
- NAS (Network Attached Storage)
- Thin Client Set-top Boxes
- Digital Media Clients/Servers
- Home Gateways

Features and Benefits

FEATURES	BENEFITS
RipStream technology combines support of multiple HD streams, software protocol stack management and security	High throughput; two HD MPEG2 or multiple MPEG4 streams
Two bidirectional TSI ports which directly interface to video processing functions	Handles multiple HD streams concurrently
Integrated 10/100 MAC/PHY with HP Auto-MDIX	Complete networking solution that eliminates the need for special "crossover" cables when connecting LAN devices together
Crypto block supports both DTCP-IP and WMDRM 10	Provides DRM copyright protection. Flexible support for major industry standards; eliminates need for separate crypto device
Video codec agnostic	Handles any video codec (MPEG2, MPEG4, WMV9/VC-1, H.264/AVC)
Can boot from Flash memory or host processor	Reduces need for additional components
Integrated DLNA, UPnP and TCP/IP stacks	Consumer Electronics interoperability; ability to recognize other UPnP devices and offload host TCP/IP implementation
Highly flexible software architecture; customer can decide whether LAN9131 or host runs UPnP stack	Allows ease of integration to various architectures; allows system designer to optimize the architecture to application needs

Network Multimedia Processing Engine Applications

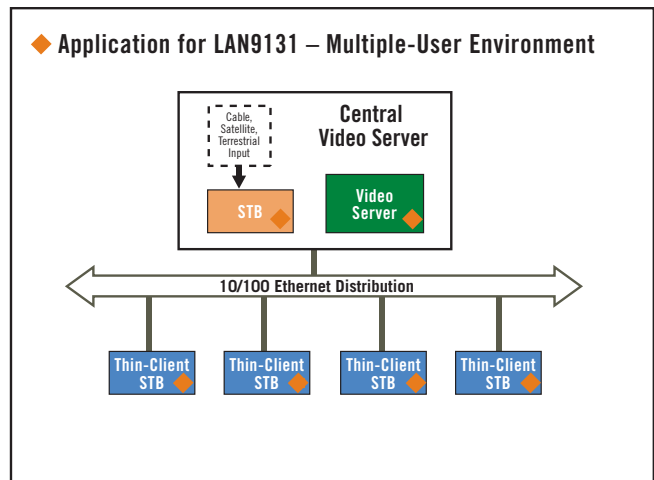
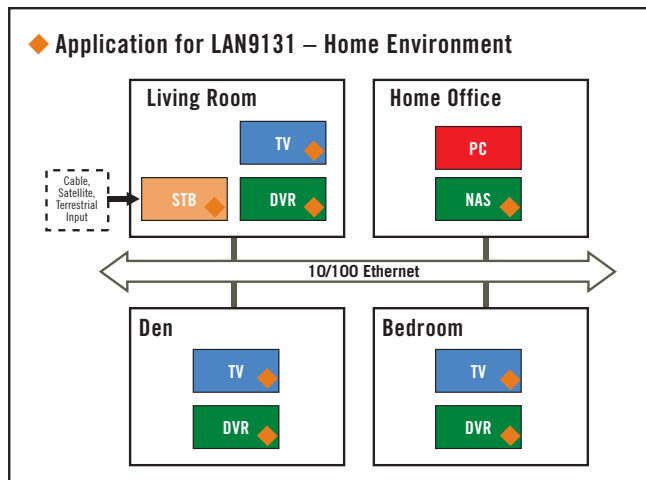

Feature and Performance-Rich

- 128-bit AES encryption/decryption
- RipStream technology provides the high-performance Ethernet data rates required to enable multiple HD streams
- TSI port can be used in server and rendering applications
- Interoperability with other UPnP-based and DLNA-compliant devices

Ease of Integration/Minimized Design Time and Risk

- Interfaces to any video coder/decoder via TSI
- Minimal host/SoC overhead
- Integrated TCP/IP stack
- Minimal software development required
- Integrated DLNA stack

Specifications*

- ARM926 integrated CPU with separate 16kbyte I- and D-caches
- 16MB SDRAM required, 32MB suggested, up to 256MB SDRAM optional
- 16/32-bit generic host bus interface connects to multiple host processors
- TSI interfaces – Serial and 8-bit Parallel modes supported
- 128-bit AES encryption/decryption
- Integrated 802.3 (10/100) Ethernet MAC/PHY with HP Auto-MDIX support
- Programmable timers, UART, I2C and SPI interfaces
- 324-pin LFBGA package
- Commercial temperature range applications (0°C to 70°C)

*please visit www.smc.com for product updates



Hardware Block Diagram

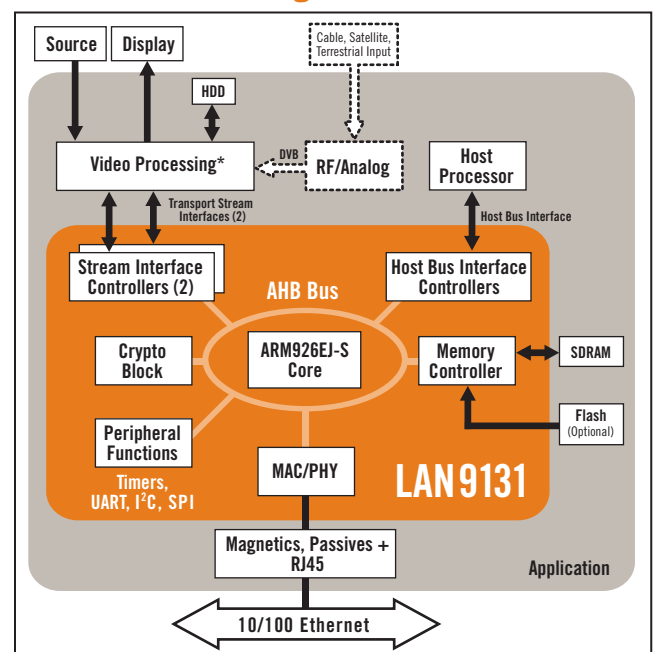

* Depending on the application, video processing can include a video decoder or encoder, MPEG PID filter or other conversion functions

Copyright ©2008 SMSC or its subsidiaries. All rights reserved. Although the information in this document has been checked and is believed to be accurate, no responsibility is assumed for inaccuracies. SMSC reserves the right to make changes to product descriptions and specifications at any time without notice. Contact your local SMSC sales office to obtain the latest specifications before placing your product order. The provision of this information does not convey any licenses under any patent rights or other intellectual property rights of SMSC or others. All sales are expressly conditional on your agreement to the terms and conditions of the most recently dated version of SMSC's standard Terms of Sale Agreement dated before the date of your order. Products may contain design defects or errors known as anomalies which may cause a product's functions to deviate from published specifications. Anomaly sheets are available upon request. SMSC products are not designed, intended, authorized or warranted for use in any life support or other application where product failure could cause or contribute to personal injury or severe property damage. Any and all such uses without prior written approval of an Officer of SMSC and further testing and/or modification will be fully at the risk of the customer. Copies of this document or other SMSC literature, as well as the Terms of Sale Agreement, may be obtained by visiting SMSC's website at <http://www.smc.com>. SMSC and the SMSC logo are registered trademarks and RipStream is a trademark of Standard Microsystems Corporation ("SMSC"). Other names mentioned may be trademarks of their respective holders. All claims made herein speak as of the date of this material. The company does not undertake to update such statements. (05/08)