



Makita

アメリカ

Condless Jig Saw

MODEL 4307D
MODEL 4307DW
With Fast Charger

INSTRUCTION MANUAL

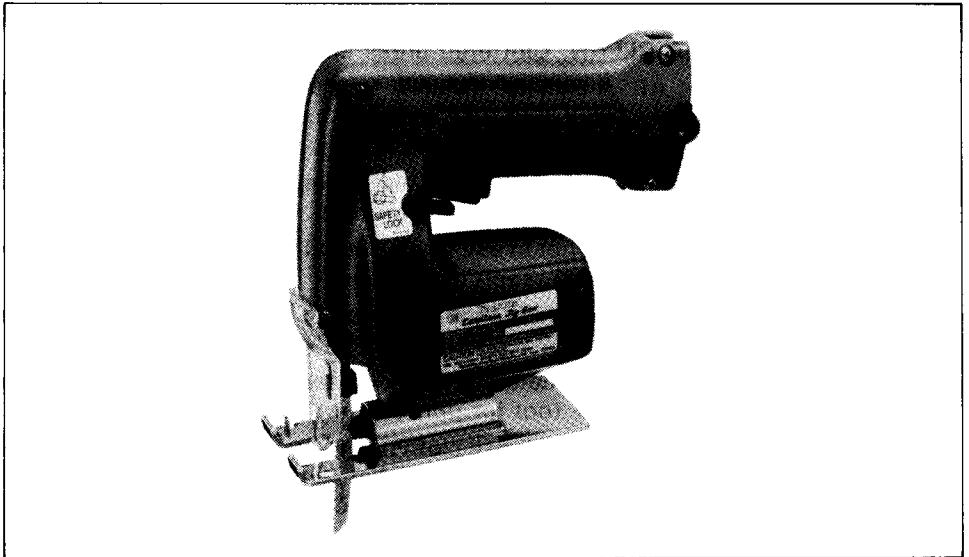

SPECIFICATIONS

• Model 4307D

Length of stroke	Max. cutting capacities			Strokes per minute	Overall length	Net weight
	Soft wood	Hard wood	Mild steel			
15 mm (9/16")	24 mm (15/16")	12 mm (1/2")	1.2 mm (3/64")	2,200	190 mm (7 15/32")	1.4 kg (3.1 lbs)

• Battery Cartridge 7000

• Model DC7100 Fast Charger

Voltage	Charging time	Input	Output	Dimensions (L x W x H)	Net weight
7.2 V	1 Hr.	A.C. only 50 Hz 60 Hz	D.C. 7.2 V	145 mm x 80 mm x 61 mm (5-3/4" x 3-1/8" x 2-3/8")	0.7 kg (1.5 lbs)

* Manufacturer reserves the right to change specifications without notice.

* Note: Specifications may differ from country to country.

IMPORTANT SAFETY INSTRUCTIONS

(For All Tools)

WARNING: WHEN USING ELECTRIC TOOLS, BASIC SAFETY PRECAUTIONS SHOULD ALWAYS BE FOLLOWED TO REDUCE THE RISK OF FIRE, ELECTRIC SHOCK, AND PERSONAL INJURY, INCLUDING THE FOLLOWING:

READ ALL INSTRUCTIONS.

- 1. KEEP WORK AREA CLEAN.** Cluttered areas and benches invite injuries.
- 2. CONSIDER WORK AREA ENVIRONMENT.** Don't use power tools in damp or wet locations. Keep work area well lit. Don't expose power tools to rain. Don't use tool in presence of flammable liquids or gases.
- 3. KEEP CHILDREN AWAY.** All visitors should be kept away from work area. Don't let visitors contact tool or extension cord.
- 4. STORE IDLE TOOLS.** When not in use, tools should be stored in dry, and high or locked-up place — out of reach of children.
- 5. DON'T FORCE TOOL.** It will do the job better and safer at the rate for which it was intended.
- 6. USE RIGHT TOOL.** Don't force small tool or attachment to do the job of a heavy-duty tool. Don't use tool for purpose not intended.
- 7. DRESS PROPERLY.** Don't wear loose clothing or jewelry. They can be caught in moving parts. Rubber gloves and non-skid footwear are recommended when working outdoors. Wear protective hair covering to contain long hair.
- 8. USE SAFETY GLASSES.** Also use face or dust mask if cutting operation is dusty.
- 9. DON'T ABUSE CORD.** Never carry tool by cord or yank it to disconnect from receptacle. Keep cord from heat, oil, and sharp edges.
- 10. SECURE WORK.** Use clamps or a vise to hold work. It's safer than using your hand and it frees both hands to operate tool.
- 11. DON'T OVERREACH.** Keep proper footing and balance at all times.
- 12. MAINTAIN TOOLS WITH CARE.** Keep tools sharp and clean for better and safer performance. Follow instructions for lubricating and changing accessories. Inspect tool cords periodically and if damaged, have repaired by authorized service facility. Inspect extension cords periodically and replace if damaged. Keep handles dry, clean, and free from oil and grease.
- 13. DISCONNECT TOOLS.** When not in use, before servicing, and when changing accessories, such as blades, bits, cutters.

14. **REMOVE ADJUSTING KEYS AND WRENCHES.** Form habit of checking to see that keys and adjusting wrenches are removed from tool before turning it on.
15. **AVOID UNINTENTIONAL STARTING.** Don't carry plugged-in tool with finger on switch. Be sure switch is OFF when plugging in.
16. **OUTDOOR USE EXTENSION CORDS.** When tool is used outdoors, use only extension cords intended for use outdoors and so marked.
17. **STAY ALERT.** Watch what you are doing, use common sense. Don't operate tool when you are tired.
18. **CHECK DAMAGED PARTS.** Before further use of the tool, a guard or other part that is damaged should be carefully checked to determine that it will operate properly and perform its intended function. Check for alignment of moving parts, binding of moving parts, breakage of parts, mounting, and any other conditions that may affect its operation. A guard or other part that is damaged should be properly repaired or replaced by an authorized service center unless otherwise indicated elsewhere in this instruction manual. Have defective switches replaced by authorized service center. Don't use tool if switch does not turn it on and off.
19. **GUARD AGAINST ELECTRIC SHOCK.** Prevent body contact with grounded surfaces. For example; pipes, radiators, ranges, refrigerator enclosures.
20. **REPLACEMENT PARTS.** When servicing, use only identical replacement parts.

VOLTAGE WARNING: Before connecting the tool to a power source (receptacle, outlet, etc.) be sure the voltage supplied is the same as that specified on the nameplate of the tool. A power source with voltage greater than that specified for the tool can result in **SERIOUS INJURY** to the user — as well as damage to the tool. If in doubt, **DO NOT PLUG IN THE TOOL.** Using a power source with voltage less than the nameplate rating is harmful to the motor.

IMPORTANT SAFETY INSTRUCTIONS

- 1. SAVE THESE INSTRUCTIONS** – This manual contains important safety and operating instructions for battery charger.
2. Before using battery charger, read all instructions and cautionary markings on (1) battery charger, (2) battery, and (3) product using battery.
3. **CAUTION** – To reduce risk of injury, charge only MAKITA Battery 7000. Other types of batteries may burst causing personal injury and damage.
4. Do not expose charger to rain or snow.
5. Use of an attachment not recommended or sold by the battery charger manufacturer may result in a risk of fire, electric shock, or injury to persons.
6. To reduce risk of damage to electric plug and cord, pull by plug rather than cord when disconnecting charger.
7. Make sure cord is located so that it will not be stepped on, tripped over, or otherwise subjected to damage or stress.
8. An extension cord should not be used unless absolutely necessary. Use of improper extension cord could result in a risk of fire and electric shock. If extension cord must be used, make sure:
 - a. That pins on plug of extension cord are the same number, size, and shape as those of plug on charger;
 - b. That extension cord is properly wired and in good electrical condition; and
 - c. That wire size is at least as large as the one specified in the table below.

TABLE 1
RECOMMENDED MINIMUM AWG SIZE FOR
EXTENSION CORDS FOR BATTERY CHARGERS

Length of Cord (Feet)	25	50	100	150
AWG Size of Cord	18	18	18	16

9. Do not operate charger with damaged cord or plug – replace them immediately.
10. Do not operate charger if it has received a sharp blow, been dropped, or otherwise damaged in any way; take it to a qualified serviceman.
11. Do not disassemble charger or battery cartridge; take it to a qualified serviceman when service or repair is required. Incorrect reassembly may result in a risk of electric shock or fire.
12. To reduce risk of electric shock, unplug charger from outlet before attempting any maintenance or cleaning. Turning off controls will not reduce this risk.

ADDITIONAL SAFETY RULES FOR CHARGER & BATTERY CARTRIDGE

1. Do not charge Battery Cartridge when temperature is BELOW 10°C (50°F) or ABOVE 40°C (104°F).
2. Do not attempt to use a step-up transformer, an engine generator or DC power receptacle.
3. Do not allow anything to cover or clog the charger vents.
4. Do not short the battery cartridge. A battery short can cause a large current flow, overheating, possible burns and even a breakdown.
5. Do not store the tool and Battery Cartridge in locations where the temperature may reach or exceed 50°C (122°F).
6. Do not incinerate the Battery Cartridge even if it is severely damaged or is completely worn out. The battery cartridge can explode in a fire.

ADDITIONAL SAFETY RULES FOR CORDLESS JIG SAW

1. Avoid cutting nails. Inspect for and remove all nails from the workpiece before operation.
2. Do not cut hollow pipe.
3. Do not cut oversize workpiece.
4. Check for the proper clearance beneath the workpiece before cutting so that the blade will not strike the floor, workbench, etc.
5. Hold the tool firmly.
6. Check the blade is not contacting the workpiece before the switch is turned on.
7. Keep hands away from moving parts.
8. When cutting through walls, floors or wherever "live" electrical wires may be encountered, **DO NOT TOUCH ANY METAL PARTS OF THE TOOL!** Hold the tool only by the plastic handle to prevent electric shock if you cutting through a "live" wire.
9. Do not leave the tool running. Operate the tool only when hand-held.
10. Always switch off and wait for the blade to come to a complete stop before removing the blade from the workpiece.
11. Do not touch the blade or the workpiece immediately after operation; they may be extremely hot and could burn your skin.

SAVE THESE INSTRUCTIONS.

Installing or removing battery cartridge

- Always switch off the tool before insertion or removal of the battery cartridge.
- To remove the battery cartridge, pull out the set plate on the tool and grasp both sides of the cartridge while withdrawing it from the barrel.
- To insert the battery cartridge, align the tongue on the battery cartridge with the groove in the housing and slip it into place. Snap the set plate back into place. Be sure to close the set plate fully before using the tool.

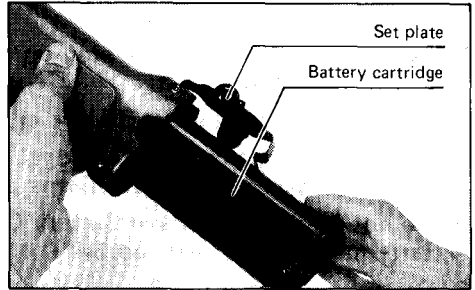

- Do not use force when inserting the battery cartridge. If the cartridge does not slide in easily, it is not being inserted correctly.

Charging

Plug the fast charger into your power source. Insert the battery cartridge so that the plus and minus terminals on the battery cartridge are on the same sides as their respective markings on the fast charger. Insert the cartridge fully into the port so that it rests on the charger port floor.

The charging light will come on and charging will begin. If the charging light does not come on, press the reset button. If the charging light goes out within 10 seconds even after pressing the reset button a couple of times, the battery cartridge is dead.

(CAUTION: Wait for more than 5 seconds after the charging light goes out to press the reset button again.) Replace it with a new one. When the charging light goes out after about one hour, you may remove the fully charged battery cartridge. After charging, unplug the charger from the power source.

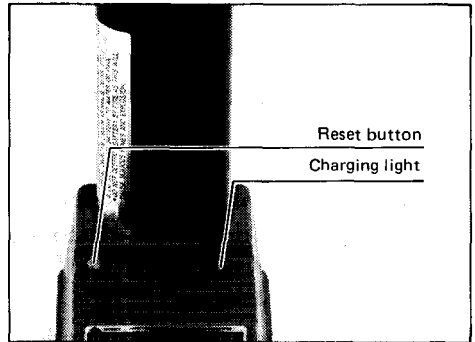

CAUTION :

- Your new battery cartridge is not charged. You will need to charge it before use.
- If you try to charge a cartridge from a just-operated tool, sometimes the charging light will not come on. If this occurs, let the cartridge cool off for a while. Then re-insert it and try to charge it once more.
- When you charge a new battery cartridge or a battery cartridge which has not been used for a long period, it may not accept a full charge. This is a normal condition and does not indicate a problem. You can recharge the battery cartridge fully after discharging it completely a couple of times.
- If you wish to charge two battery cartridges, allow 15 minutes between chargings on the fast charger.

Mounting blade

First, use the hex wrench to remove the bolt which secures the blade clamp to the blade holder shaft. With the blade teeth facing forward, place the shank of the blade over the flat side of the blade holder shaft. Then place the blade clamp over the other side of the blade shank. Secure this assembly together with bolt. Make sure that the bolt passes through the larger hole in the blade shank.

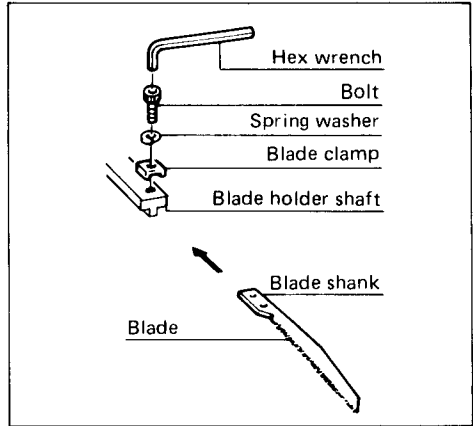

Using roller

With the hex wrench loosen the bolt which holds the base and retainer. Slide the retainer so that the roller contacts the blade, then tighten the bolt.

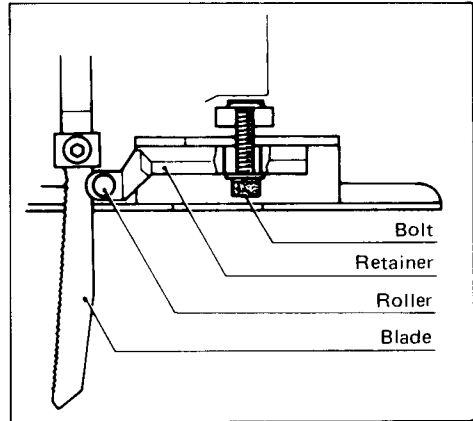

Use a lubricant or cutting oil between the blade and roller when cutting metals. Failure to do so will shorten the service life of your blade and roller.

Switch action

To prevent the trigger from being accidentally pulled a lock-off lever is provided as a safety feature.

To start the tool, set the lock-off lever as shown in the figure and pull the trigger. Release the trigger to stop.

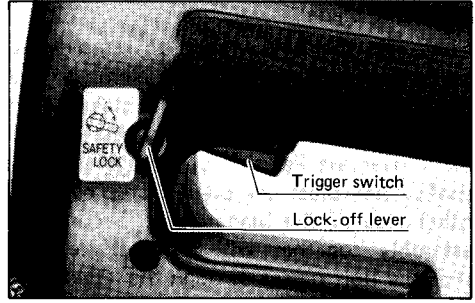

CAUTION:

- Before inserting the battery cartridge into the tool, always check to see that the trigger switch actuates properly and returns to the "OFF" position when released.
- When not operating the tool, keep the lock-off lever in the SAFETY LOCK position.
- Pulling the trigger hard when the lock-off lever is set to the SAFETY LOCK position can cause switch breakage.

Operation

Turn the tool on before contacting the workpiece. Then rest the base flat on the workpiece and gently move the tool forward along the previously marked cutting line.

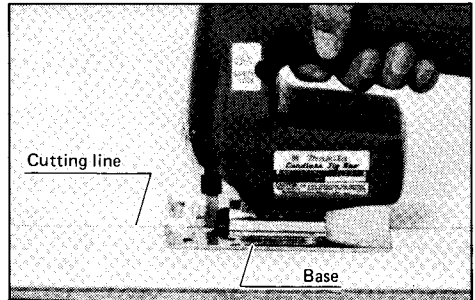

Plunge cutting

Starting a cut at other than the edge of the workpiece without first drilling a starting hole requires a "plunge cut." This can be accomplished by tipping the tool forward until the front end of the base rests against the workpiece. Switch the tool on and lower the back end of the tool slowly, gradually allowing the blade to saw through the wood until the base is able to sit flat on the workpiece. You may then proceed forward with the cut in a normal manner.

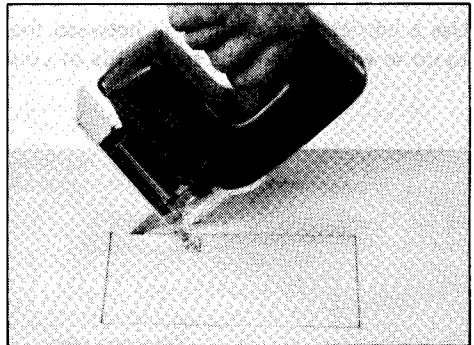

If using a drill for a starting hole, bore a hole over 12 mm (1/2") in diameter. Then insert the blade in it and proceed.

Front flush cuts

Loosen the bolt on the back of the base with the hex wrench, then slide the base backwards. Check the contact between the back edge of the blade and support roller, then secure the bolt.

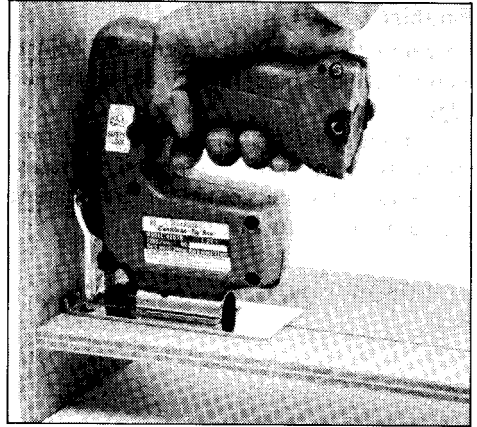

Bevel cutting

1. With the base tilted, you can make bevel cuts at any angle between 0° and 45° (left or right).

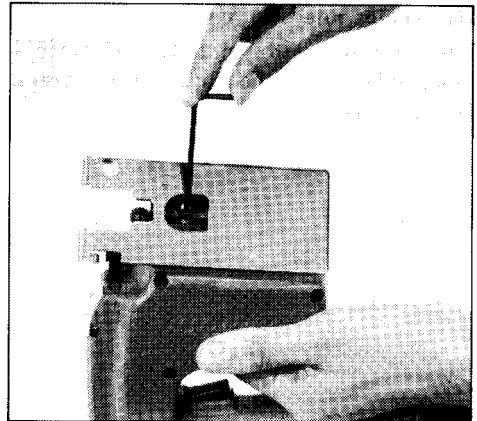

2. Loosen the bolt on the back of the base with the hex wrench. Tilt the base to the desired angle. The edge of the housing indicates the bevel angle. Then check for contact between the back edge of the blade and the roller. Now tighten the bolt securely on the back of the base.

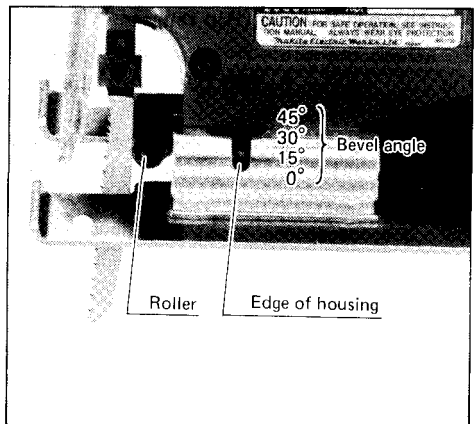

Finishing edges

To trim edges or make dimensional adjustments, run the blade lightly along the cut edges.

For smoother cutting of plywoods or other materials with easily splintered surfaces, the wood may be coated or transparent tape used over your cutting line.

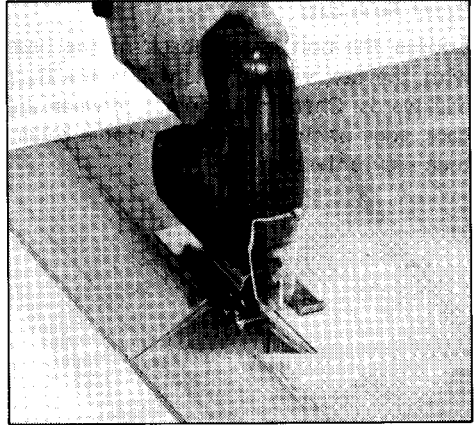

Using guide rule (Rip fence)

When cutting widths of under 150mm (6") repeatedly, use of the guide rule will assure fast, clean cuts.

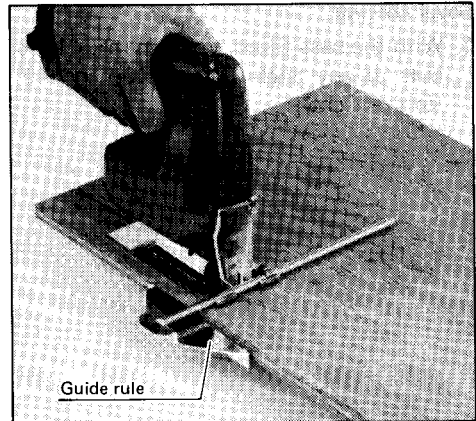

Attaching guide rule (Rip fence)

To attach the guide rule (rip fence), secure the rule holder to the base with the hex screw (do not tighten).

Insert the guide rule between the base and the rule holder. Now tighten the hex screw with the hex wrench.

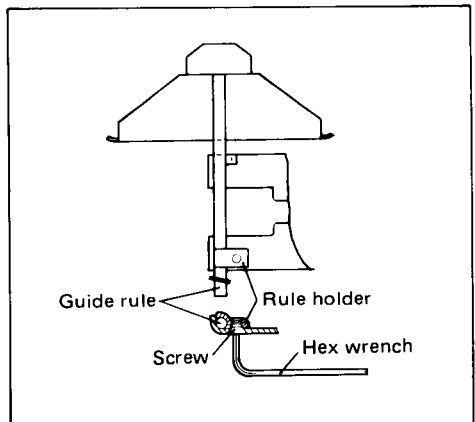

Using circular guide

1. Use of the circular guide insures clean, smooth cutting of circles (radius; under 200 mm ; 7-7/8'') and arcs.

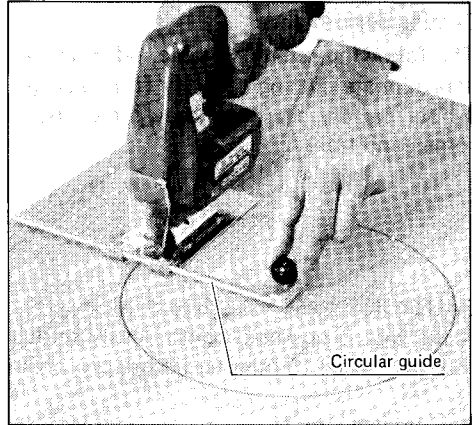

2. When attaching the circular guide, use the pin, inserting it in the center hole (arrow) and secure it with the threaded knob. The circular guide attaches to the base of the tool in the same manner as the guide rule (rip fence).

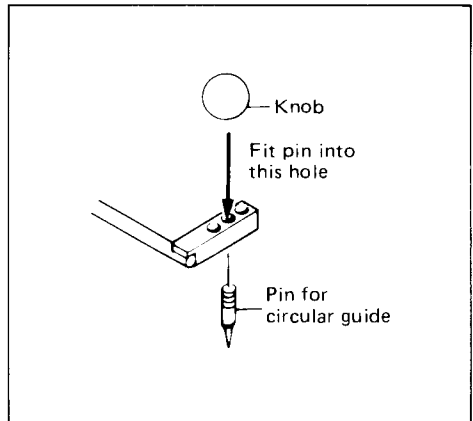

Metal cutting

Always use a suitable coolant (cutting oil) when cutting metal. Failure to do so will cause significant blade wear.

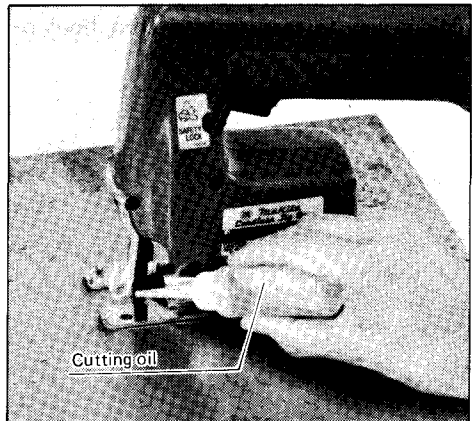

Cutting performance

The following reference table indicates the approximate cutting capacity from a single 1-hour battery charge. It may differ under some conditions.

Material	Thickness	Cutting length
Soft wood	12 mm (1/2")	11 m (36 ft)
	24 mm (15/16")	2.5 m (8.2 ft)
Hard wood	12 mm (1/2")	4 m (13 ft)
Mild steel	1.2 mm (3/64")	3 m (9.8 ft)

CAUTION:

If the tool is operated continuously until the battery cartridge has discharged, allow the tool to rest for 15 minutes before proceeding with a fresh battery.

Hex wrench storage

When not in use, the hex wrench can be conveniently stored.

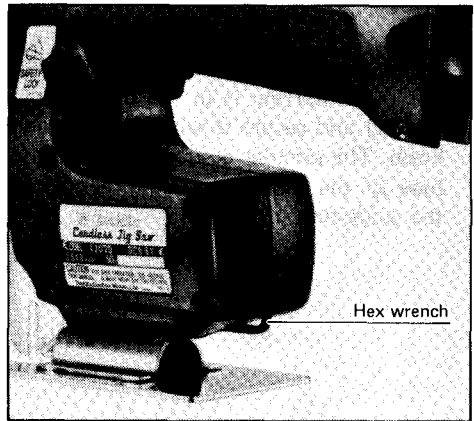

Hole

The hole on the heel of the tool is a convenient way to carry it by a cord, hook or other means.

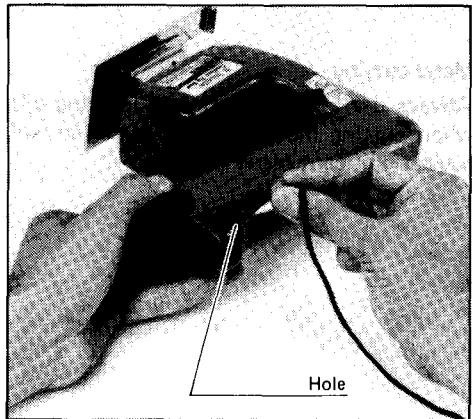

MAINTENANCE

CAUTION:

Always be sure that the tool is switched off and the battery cartridge is removed before attempting to perform inspection or maintenance.



To maintain product **SAFETY** and **RELIABILITY**, repairs, maintenance and adjustment should be performed by Makita Authorized or Factory Service Centers, always using Makita replacement parts.

ACCESSORIES

CAUTION :

These accessories or attachments are recommended for use with your Makita tool specified in this manual. The use of any other accessories or attachments might present a risk of injury to persons. The accessories or attachments should be used only in the proper and intended manner.

- **Jig saw blade** (packed 5 each in handy vinyl pouch)

Blade type	Part No.	Teeth per inch	Overall length	Applications
No. 31 	792221-5	24	80 mm (3-5/32")	Extra-fine blade for mild steel, plys, masonite, plastics, formica, etc.
No. 39 	792222-3	12	80 mm (3-5/32")	Ideal for wood cutting.

- **Guide rule (Rip fence)**

Part No. 164113-2



- **Circular guide assembly**

Part No. 123030-5



- **Hex wrench 3**

Part No. 783201-2



- **Rule holder assembly**

Part No. 191602-4



- **Fast charger**

Model DC7100



- **12 V Fast charger**

Model DC7012



- **Battery cartridge 7000**

1-hour fast charge nickel cadmium battery
Part No. 632003-2



- **Battery holster**

Holster holds extra battery
Part No. 823033-3C

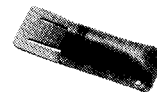

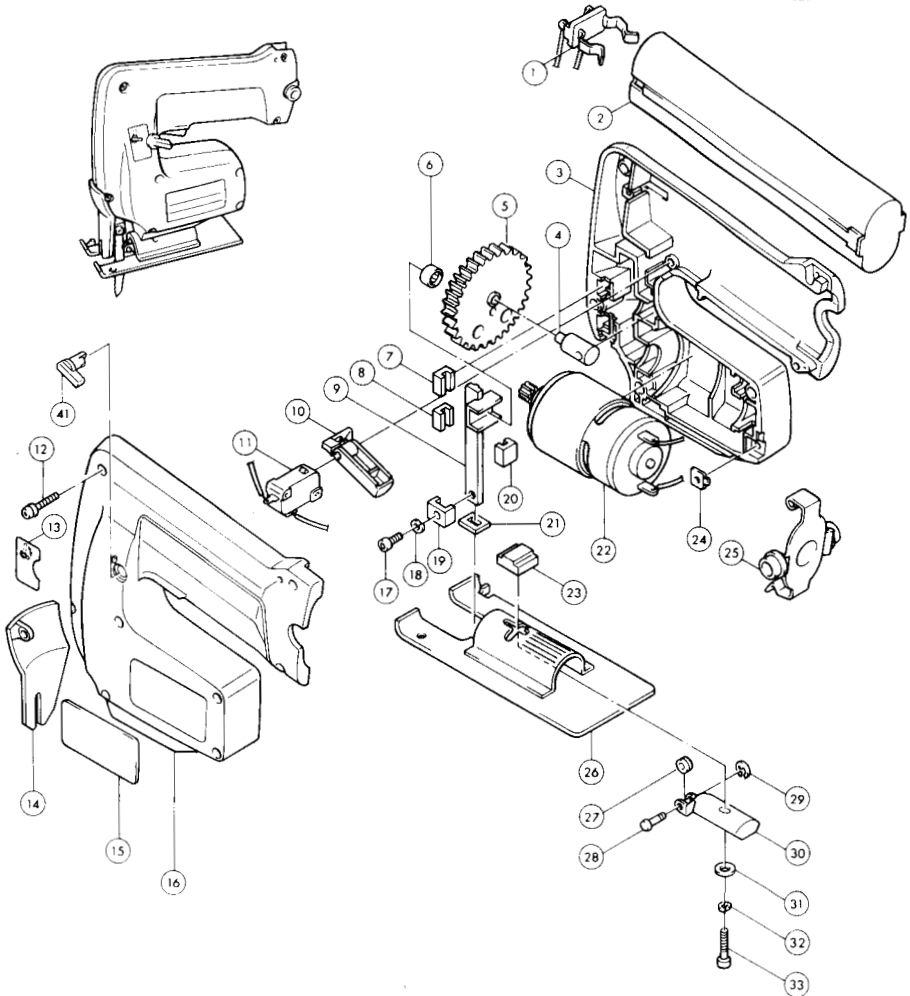

CORDLESS JIG SAW Model 4307D

Type1

Note: The switch and other part configurations may differ from country to country.

ITEM NO.	NO. USED	DESCRIPTION	ITEM NO.	NO. USED	DESCRIPTION
MACHINE			MACHINE		
1	1	Battery Holder	18	1	Spring Washer 4
2	1	Battery 7000	19	1	Blade Set
3	1	Housing Set (With Item 16)	20	1	Plane Bearing 3
4	1	Supporter	21	1	Felt
5	1	Gear	22	1	Motor
6	1	Needle Bearing 407	23	1	Holder
7	1	Plane Bearing 3	24	1	Leaf Spring
8	1	Plane Bearing 3	25	1	Set Plate
9	1	Slider	26	1	Base
10	1	Trigger	27	1	Roller
11	1	Switch	28	1	Pin 3
12	8	Pan Head Screw M4x22 (With Washer)	29	1	Stop Ring E - 2.3
13	1	Indication Label	30	1	Retainer
14	1	Protector	31	1	Flat Washer 4
15	1	Name Plate	32	1	Spring Washer 4
16	1	Housing Set (With Item 3)	33	1	Hex. Socket Head Bolt M4x18
17	1	Hex. Socket Head Bolt M4x8	41	1	Lock Off Lever

Note: The switch and other part specifications may differ from country to country.

MAKITA LIMITED ONE YEAR WARRANTY

Warranty Policy

Every Makita tool is thoroughly inspected and tested before leaving the factory. It is warranted to be free of defects from workmanship and materials for the period of ONE YEAR from the date of original purchase. Should any trouble develop during this one-year period, return the COMPLETE tool, freight prepaid, to one of Makita's Factory or Authorized Service Centers. If inspection shows the trouble is caused by defective workmanship or material, Makita will repair (or at our option, replace) without charge.

This Warranty does not apply where:

- repairs have been made or attempted by others;
- repairs are required because of normal wear and tear;
- The tool has been abused, misused or improperly maintained;
- alterations have been made to the tool.

IN NO EVENT SHALL MAKITA BE LIABLE FOR ANY INDIRECT, INCIDENTAL OR CONSEQUENTIAL DAMAGES FROM THE SALE OR USE OF THE PRODUCT. THIS DISCLAIMER APPLIES BOTH DURING AND AFTER THE TERM OF THIS WARRANTY.

MAKITA DISCLAIMS LIABILITY FOR ANY IMPLIED WARRANTIES, INCLUDING IMPLIED WARRANTIES OF "MERCHANTABILITY" AND "FITNESS FOR A SPECIFIC PURPOSE," AFTER THE ONE-YEAR TERM OF THIS WARRANTY.

This Warranty gives you specific legal rights, and you may also have other rights which vary from state to state. Some states do not allow the exclusion or limitation of incidental or consequential damages, so the above limitation or exclusion may not apply to you. Some states do not allow limitation on how long an implied warranty lasts, so the above limitation may not apply to you.



Makita Electric Works, Ltd.

11-8, 3-chome, Sumiyoshi-cho, Anjo, Aichi 446, Japan

883561A065

PRINTED IN JAPAN
1989-8-N