

Doodle Pro™ Glow

Instructions
Model Number H5791



Please keep this instruction sheet for future reference,
as it contains important information.

Requires four "AA" (LR6) **alkaline** batteries (not included).

Adult assembly is required for battery installation.

Tool required for battery installation:
Phillips screwdriver (not included).

Fisher-Price®

www.fisher-price.com

Battery Installation

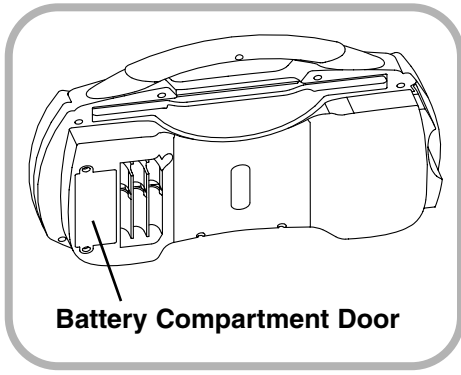

- Locate the battery compartment on the back of the toy.
 - Loosen the screws in the battery compartment door with a Phillips screwdriver. Remove the battery compartment door.
 - Insert four "AA" (LR6) **alkaline** batteries, as indicated inside the battery compartment.
- Hint:** We recommend using **alkaline** batteries for longer life.
- Replace the battery compartment door and tighten the screws with a Phillips screwdriver. Do not over-tighten.
 - When lights become faint or stop, it's time for an adult to change the batteries!

Battery Safety Information

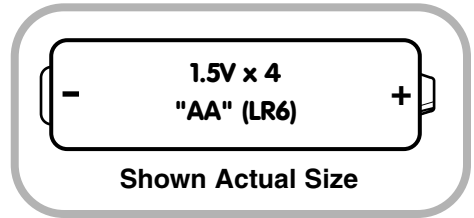

Batteries may leak fluids that can cause a chemical burn injury or ruin your toy. To avoid battery leakage:

- Do not mix old and new batteries or batteries of different types: alkaline, standard (carbon-zinc) or rechargeable (nickel-cadmium).
- Insert batteries as indicated inside the battery compartment.
- Remove batteries during long periods of non-use. Always remove exhausted batteries from the toy. Dispose of batteries safely. Do not dispose of batteries in a fire. The batteries may explode or leak.
- Never short-circuit the battery terminals.
- Use only batteries of the same or equivalent type, as recommended.
- Do not charge non-rechargeable batteries.
- Remove rechargeable batteries from the toy before charging.
- If removable, rechargeable batteries are used, they are only to be charged under adult supervision.

Let's Draw!

1

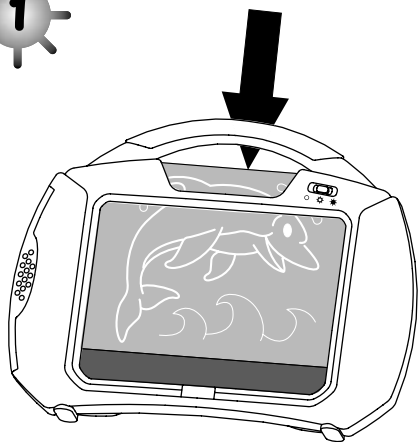

2

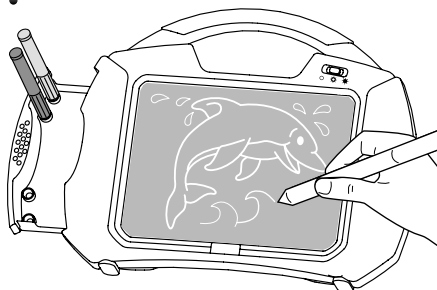

- Use one of the glow makers included to trace the design or create a design of your own without the template!

Hints:

- Draw thin lines to create a "neon" effect.
- Be sure to let markings dry at least 15 seconds before touching.
- As you work, store extra markers upright in the holes in the drawer.

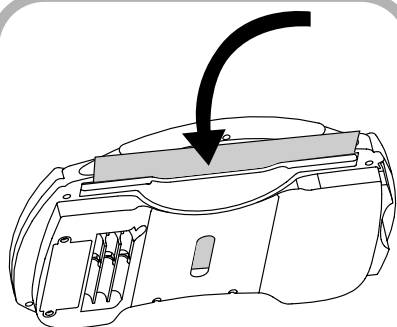

BACK VIEW

- Slide a tracing template or any image you wish to trace, into the slot in the back of the toy.

Light it Up!

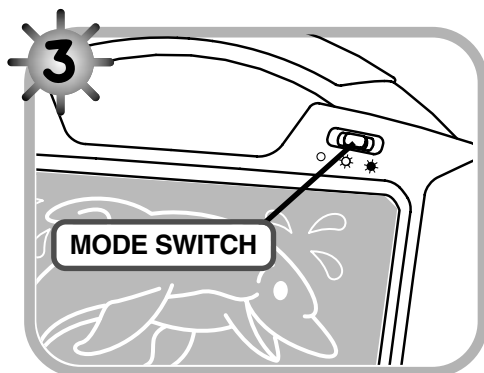

- Locate the mode switch near the top of the toy.
- The switch has three positions: off ○; blink ⚙ and glow ✨.
- Set the switch to glow ✨ to light up your creation!
- Set the switch to blink ⚙ to create an attention grabbing sign! Your image flashes on and off!

Erasing

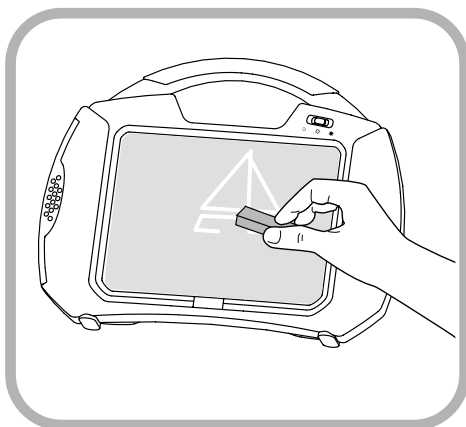

- Dampen the eraser with water. Wipe the drawing surface with the eraser.

IMPORTANT!

- To completely remove glow marker residue from the drawing surface, wipe it with a damp cloth after each use.
- Use only Doodle Pro™ Glow markers. Not all markers are made especially for children. Fisher-Price® markers are safe and non-toxic but may stain some porous surfaces such as clothing, carpet and furniture. Do not use permanent markers on the drawing surface. Adult supervision is recommended.
- To remove marker from the skin, simply use soap and water.

Storage

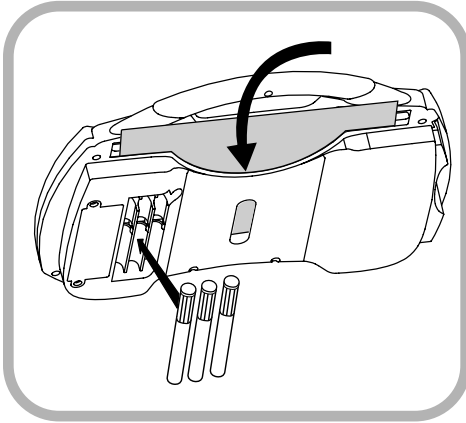

- Slide the mode switch to the off \circ position.
- Snap the markers into the storage slots on the back of the toy.

Hint: Be sure to replace the caps tightly on the markers to prevent them from drying out.

- Store your tracing templates in the slot on the back of the toy.

Care

- Wipe this toy with a clean, damp cloth.
- This toy has no consumer serviceable parts. Do not take this toy apart.
- Do not apply heavy pressure or force to the drawing screen.

FCC Note (United States Only)

Note: This equipment has been tested and found to comply with the limits for a Class B digital device, pursuant to Part 15 of the FCC Rules. These limits are designed to provide reasonable protection against harmful interference in a residential installation. This equipment generates, uses and can radiate radio frequency energy and, if not installed and used in accordance with the instructions, may cause harmful interference to radio communications. However, there is no guarantee that interference will not occur in a particular installation. If this equipment does cause harmful interference to radio or television reception, which can be determined by turning the equipment off and on, the user is encouraged to try to correct the interference by one or more of the following measures:

- Reorient or relocate the receiving antenna.
- Increase the separation between the equipment and receiver.
- Consult the dealer or an experienced radio/TV technician for help.

Note: Changes or modifications not expressly approved by the manufacturer responsible for compliance could void the user's authority to operate the equipment.

Look for Doodle Pro™ Glow Accessory Packs

Consumer Information

**More glow markers in more glow
colors, plus fun tracing templates!**

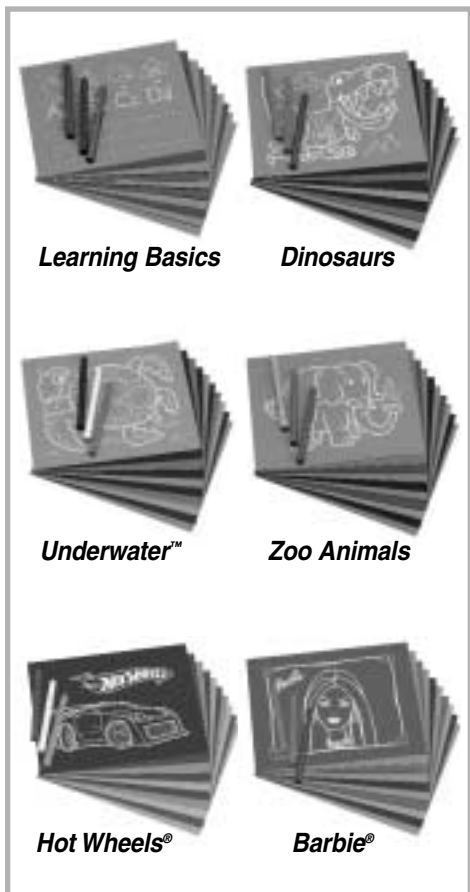

Questions? We'd like to hear from you!

Call Fisher-Price® Consumer Relations, toll-free at **1-800-432-5437**, 8 AM - 6 PM EST Monday through Friday. Hearing-impaired consumers using TTY/TDD equipment, please call 1-800-382-7470. Or, visit us on line at **www.service.mattel.com**.

Write to us at: Fisher-Price® Consumer Relations, 636 Girard Avenue, East Aurora, New York 14052.

For countries outside the United States:

CANADA: Questions? **1-800-432-5437**. Mattel Canada Inc., 6155 Freemont Blvd., Mississauga, Ontario L5R 3W2; www.service.mattel.com.

GREAT BRITAIN: Mattel UK Ltd, Vanwall Business Park, Maidenhead SL6 4UB. Helpline: 01628 500302.

AUSTRALIA: Mattel Australia Pty. Ltd., 658 Church Street, Locked Bag #870, Richmond, Victoria 3121 Australia. Consumer Advisory Service 1300 135 312.

NEW ZEALAND: 16-18 William Pickering Drive, Albany 1331, Auckland.

ASIA: Mattel East Asia Ltd, Room 1106, South Tower, World Finance Centre, Harbour City, Tsimshatsui, HK, China.