

PULSAFEEDER[®]

A Unit of IDEX Corporation



Installation, Operation, & Maintenance Instruction

Models DC2, 3, 4, 5, and 6

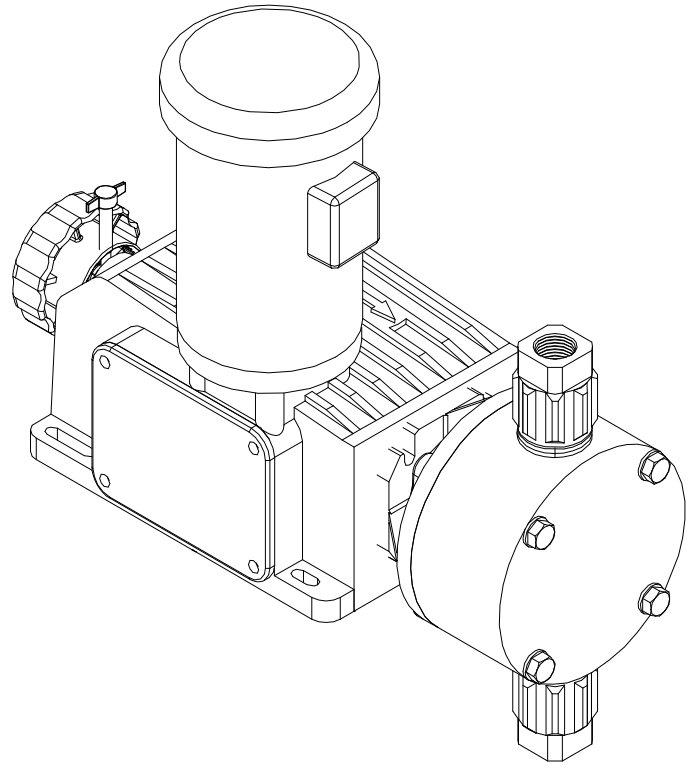

Bulletin #: IOM-OM-1104- E

 **PULSAFEEDER**
A Unit of IDEX Corporation

Manufacturers of Quality Pumps,
Controls, and Systems

STANDARD PUMP OPERATIONS
27101 Airport Road
Punta Gorda, FL 33982
(941) 575-3800 Fax (941) 575-4085
www.pulsatron.com

Pulsafeeder Factory Service Policy

Should you experience a problem with your Pulsafeeder pump, first consult the troubleshooting guide in your operation and maintenance manual. If the problem is not covered or cannot be solved, please contact your local Pulsafeeder Sales Representative or Distributor, or our Technical Services Department for further assistance.

Trained technicians are available to diagnose your problem and arrange a solution. Solutions may include purchase of replacement parts or returning the unit to the factory for inspection and repair. All returns require a Return Authorization number to be issued by Pulsafeeder. Parts purchased to correct a warranty issue may be credited after an examination of original parts by Pulsafeeder. Warranty parts returned as defective which test good will be sent back freight collect. No credit will be issued on any replacement electronic parts.

Any modifications or out-of-warranty repairs will be subject to bench fees and costs associated with replacement parts.

Safety Considerations:

1. Read and understand all related instructions and documentation before attempting to install or maintain this equipment
2. Observe all special instructions, notes, and cautions.
3. Act with care and exercise good common sense and judgment during all installation, adjustment, and maintenance procedures.
4. Ensure that all safety and work procedures and standards that are applicable to your company and facility are followed during the installation, maintenance, and operation of this equipment.

Revision History:

Rev B (3-1-05)

- Update diagram fig. 10
- Revise text step 11b page 11 diaphragm removal and replacement
- Update all parts diagrams and lists, Section 12

Rev C (9-1-06)

- Update for Kynar (PVDF) heads
- Add model string ID page
- Update KOPkit list with PVDF kits
- Update parts lists with PVDF parts

Rev E (2-2007)

- Update all for introduction of model DC6, SPO address only
- Update materials references to "PTFE"

Copyright ©2004, 2006, 2007 Pulsafeeder, Inc. All rights reserved.

Information in this document is subject to change without notice. No part of this publication may be reproduced, stored in a retrieval system or transmitted in any form or any means electronic or mechanical, including photocopying and recording for any purpose other than the purchaser's personal use without the written permission of Pulsafeeder, Inc.

Table of Contents

| | |
|---|----|
| 1. INTRODUCTION | 1 |
| 2. PRINCIPLES OF OPERATION | 1 |
| 2.1 Reagent Head Assembly | 2 |
| 2.2 Control Assembly | 2 |
| 2.3 Gear Ratio Assembly | 2 |
| 3. EQUIPMENT INSPECTION | 3 |
| 4. STORAGE | 3 |
| 5. INSTALLATION | 3 |
| 5.1 Location | 3 |
| 5.2 Piping System | 4 |
| 5.3 Suction Pressure Requirements | 5 |
| 5.4 Discharge Pressure Requirements | 5 |
| 6. EQUIPMENT STARTUP | 6 |
| 6.1 Fastener Inspection | 6 |
| 6.2 Output Adjustment | 6 |
| 6.3 Priming the Reagent Head | 7 |
| 6.4 Calibration | 8 |
| 7. MAINTENANCE | 9 |
| 7.1 Lubrication | 9 |
| 7.2 Wet End Removal, Inspection, & Reinstallation | 10 |
| 7.3 Check Valves | 12 |
| 7.4 Motor Removal & Reinstallation | 16 |
| 7.5 Gearset Removal | 16 |
| 7.6 Gearset Replacement | 18 |
| 8. REPLACEMENT PARTS | 19 |
| 8.1 KOPkit Program | 19 |
| 8.2 Ordering KOPkits or Parts | 19 |

| | | |
|------|-------------------------------------|----|
| 8.3 | KOPkit numbers by model: | 20 |
| 9. | MODEL NUMBER IDENTIFICATION..... | 21 |
| 10. | WET END MATERIALS REFERENCE..... | 22 |
| 11. | TROUBLESHOOTING | 23 |
| 12. | PIPING ACCESSORIES | 25 |
| 13. | DIMENSIONAL DRAWING..... | 26 |
| 14. | PARTS DIAGRAMS AND PARTS LISTS..... | 28 |
| 14.1 | Parts diagram, DC2 and 3..... | 28 |
| 14.2 | Bill of Materials, DC2..... | 29 |
| 14.3 | Bill of Materials, DC3..... | 31 |
| 14.4 | Parts Diagram, DC4, 5, and 6..... | 34 |
| 14.5 | Bill of Materials, DC4..... | 35 |
| 14.6 | Bill of Materials, DC5..... | 37 |
| 14.7 | Bill of Materials, DC6..... | 39 |

1. Introduction

The OMNI[®] metering pump is positive displacement, mechanically operated reciprocating diaphragm pump. Each pump consists of a power end and a process end separated by a PTFE faced diaphragm. Individual pumps will vary in appearance due to various liquid ends and accessories; however, the basic principles of operation remain the same.

2. Principles Of Operation

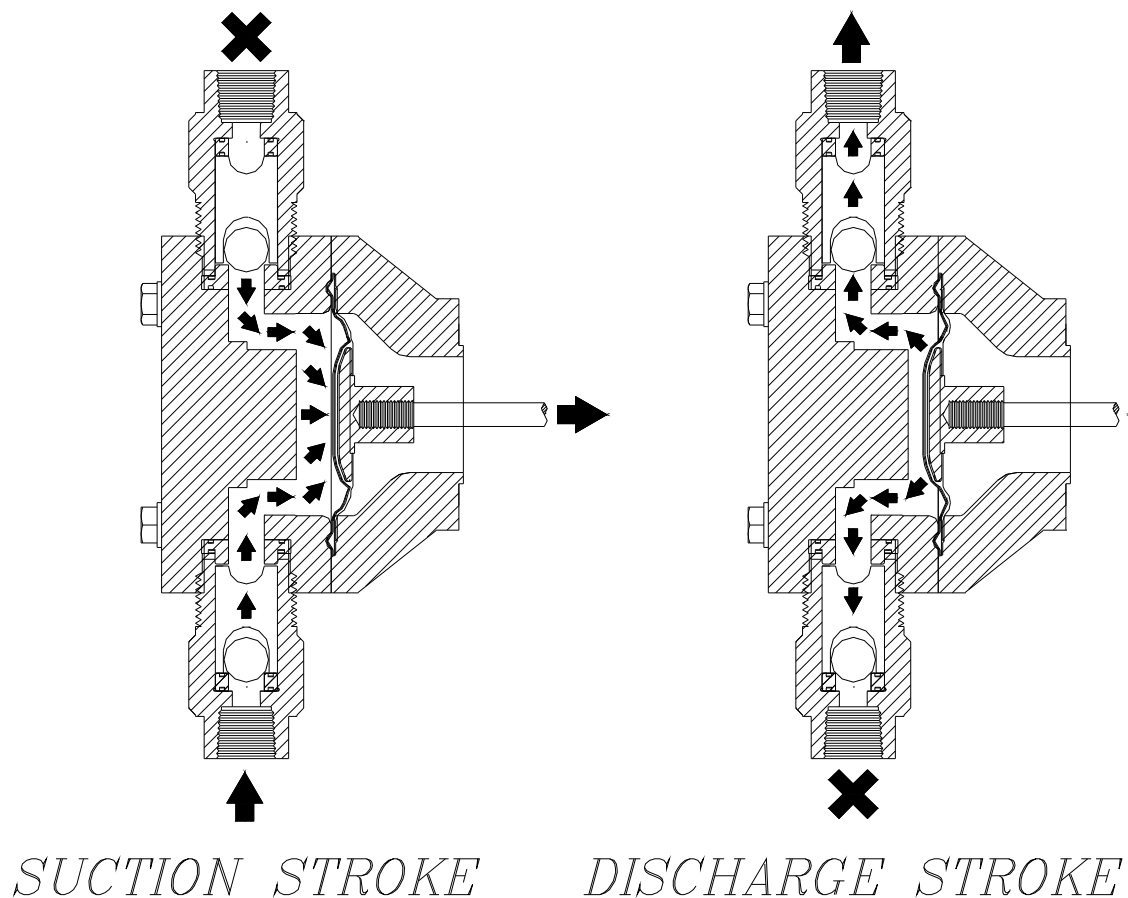

Figure 1, reagent head operation

A diaphragm reciprocates at a preset stroke length, displacing an exact volume of process fluid. Diaphragm retraction causes the product to enter through the suction check valve. Diaphragm advance causes the discharge of an equal amount of the product through the discharge check valve.

2.1 Reagent Head Assembly

The typical reagent head assembly consists of reagent head, diaphragm, and suction and discharge cartridge check valves. This assembly is the only part of the pump to contact the process liquid; consequently, maintenance is critical to pump performance.

2.2 Control Assembly

The OMNI[®] pump incorporates a lost motion style of stroke length adjustment to limit diaphragm travel during the suction portion of each stroke. The stroke length setting is indicated by a (0% – 100%) scale located on the stroke adjustment assembly.

Stroke length is changed by loosening the locking screw and turning the hand knob. This turns a mechanism, which limits rearward travel of the diaphragm. Refer to **Section 6.2** for further information.

For automatic flow rate control, users can consider the Pulsafeeder MPC speed based control system, please contact your local Pulsafeeder dealer or representative for more information.

2.3 Gear Ratio Assembly

OMNI[®] pumps are driven by an electric motor mounted on the motor adaptor input flange. The motor drives a set of worm gears that convert rotational speed into torque. They, in turn, power the eccentric shaft assembly that converts rotary motion into reciprocating motion.

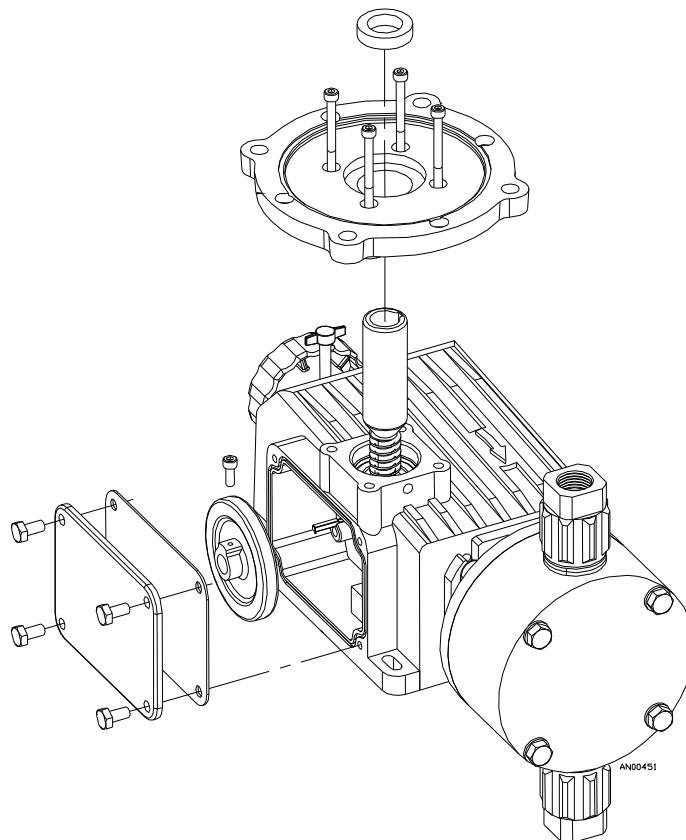

Figure 2, isometric view

3. Equipment Inspection

Check all equipment for completeness against the order and for any evidence of shipping damage. Shortages or damage must be reported immediately to the carrier and your authorized representative or distributor of OMNI® pumps.

4. Storage

4.1.1 Short Term

Storage of your OMNI® pump for up to 12 months is considered short-term. The recommended short-term storage procedures are:

- a) Store the pump indoors at room temperature in a dry environment.
- b) If required by the operating environment, take precautions to prevent entry of water or humid air into the eccentric enclosure.
- c) Prior to startup, perform a complete inspection and then start up in accordance with instructions in this manual.

4.1.2 Long Term

Every twelve months, in addition to the above short-term procedures, power up the motor and operate the pump for a minimum of one hour. It is not necessary to have liquid in the reagent head during this operation, but the suction and discharge ports must be open to atmosphere.

After twelve months of storage, Pulsafeeder's warranty cannot cover items that are subject to deterioration with age, such as seals, gaskets, and diaphragms. If the pump has been in storage longer than 12 months it is recommended that these items be inspected and replaced as necessary prior to startup. Materials and labor to replace this class of item under this circumstance are the purchaser's responsibility. Consult your local Pulsafeeder representative for assistance in obtaining parts and service for your pump.

5. Installation

5.1 Location

When selecting an installation site or designing a chemical feed system, consideration should be given to access for routine maintenance.

OMNI® pumps are designed to operate indoors and outdoors, but it is desirable to provide a hood or covering for outdoor service. External heating is required if ambient temperatures below 0° C (32° F) are anticipated, especially if pumps are not in continuous duty. Check with the factory if concerned with the suitability of the operating environment.

The pump must be rigidly bolted to a solid and flat foundation to minimize vibration, which can loosen connections. When the pump is bolted down, care must be taken to avoid distorting the base and affecting alignments. The pump must be level within 5°. This will assure that the check valves can operate properly.

5.2 Piping System

1. All systems should include a pressure relief valve on the discharge side, to protect piping and process equipment, including the pump, from excess process pressures. **An external relief valve is required!** There should be no devices capable of restricting flow (such as a valve) located between the pump and the relief device.
2. Shutoff valves and unions (or flanges) on suction and discharge piping are recommended. This permits check valve inspection without draining long runs of piping, making periodic maintenance and inspection easier.

Shutoff valves should be of the same size as connecting pipe. Ball valves are preferred since they offer minimum flow restriction.

3. Suction systems should include an inlet strainer, if appropriate for the product being pumped. Pump check valves are susceptible to dirt and other solid contaminants, and any accumulation can cause malfunction. The strainer should be located between the suction shutoff valve and the pump suction valve. It must be sized to accommodate the flow rate and the anticipated level of contamination. A 100 mesh screen size is generally recommended.
4. Vacuum/pressure gauges in the suction and discharge lines are helpful in order to check system operation. Gauges should be fitted with protective shutoff valves for isolation while not in use.
5. Piping weight must not be supported by valve housings or other portions of the reagent head, as the resulting stresses can cause leaks. If appropriate, provide for thermal expansion and contraction so that no excess force or moments are applied to the pump.
6. When making process connections, ensure that the check valve assemblies do not rotate as the threaded connections are secured. It is critical, especially with plastic construction, that the check valves not be too tight into the reagent head. The threaded connection between the check valve assembly and the reagent head uses an o-ring seal and does not require sealing tape or any other sealant.
7. In piping assembly, use a sealing compound chemically compatible with the process material. Users of sealing tape are cautioned to ensure that the entering pipe thread ends are not taped, and that tape is removed from previously-used threads to the maximum practical extent prior to re-use. Both new and existing piping should be cleaned, preferably by flushing with a clean liquid (compatible with process material) and blown out with air, prior to connection to the pump. Debris from the piping system that prevents proper check valve operation is a common startup issue.
8. Note that for pumps which utilize cartridge-type check valve assemblies, no thread tape or sealant is required on the threads which secure the cartridge assembly to the pump reagent head. This area is sealed with o-rings integral to the cartridge. Sealant on these threads can actually degrade sealing capability.

5.3 Suction Pressure Requirements

Although OMNI® metering pumps have some suction lift capability, a flooded suction (i.e., suction pressure higher than atmospheric pressure) is preferable whenever possible. The pump should be located as close as possible to the suction side reservoir or fluid supply source.

For fluid with a vapor pressure of 5 psia or less (at operating temperature) the wet suction lift capability is approximately ten (10) feet. If this requirement is not met, the pump will not provide reliable, accurate flow. In suction lift conditions, the use of a foot valve is recommended at the lowest point of the pickup tube or pipe. Pumps under suction lift conditions may require some liquid priming before they will operate reliably.

5.4 Discharge Pressure Requirements

All OMNI® metering pumps are designed for continuous service at the rated discharge pressure. If system suction pressure exceeds discharge pressure (a condition sometimes described as “pumping downhill”), flow would be generated (siphoning) in addition to that caused by the pump. This results in a reduction in accuracy and loss of control over the metering process. To prevent this flow-through condition, the discharge pressure must exceed suction pressure by at least 0.35 Bar (5 psi). This can be achieved where necessary by the installation of a backpressure valve in the discharge line. Conditions where the actual discharge pressure exceeds the pump’s rating are to be avoided as they will cause damage to the pump components.

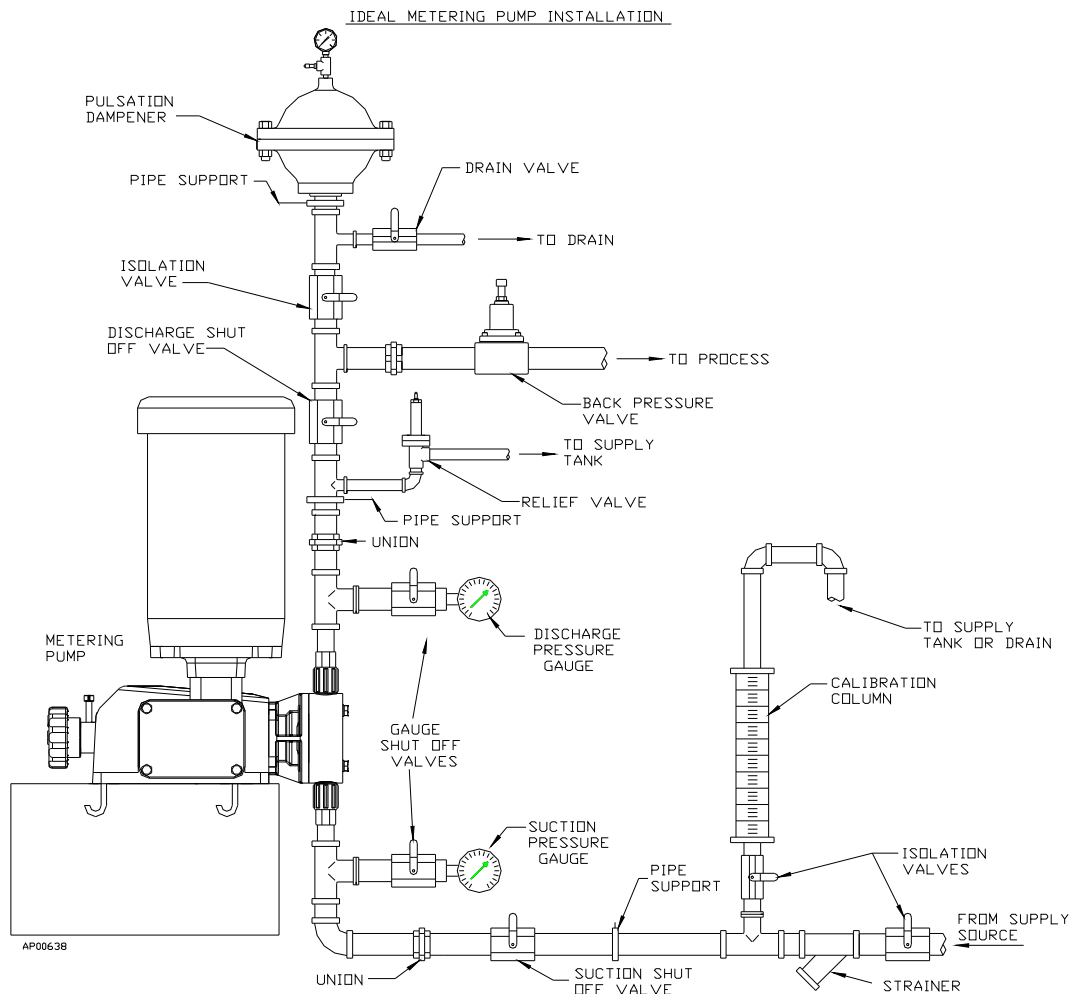

Figure 3, sample system configuration

6. Equipment Startup

6.1 Fastener Inspection

All pump fasteners should be checked prior to pump operation, and occasionally during use. This would include reagent head mounting bolts, motor mounting bolts, and the hardware that secures the pump to its foundation. Most hardware can be checked simply to ensure it is not loose. However, utilize the following values when checking reagent head bolt torque:

| Model | Material | Reagent Head Bolt Torque | | |
|-----------|----------|--------------------------|------|-----------|
| | | # Bolts and size | N-m | In. - Lbs |
| DC2 | Plastic | (4) M6 * 1.0 | 3.39 | 30 |
| | Metal | (4) M6 * 1.0 | 3.39 | 30 |
| DC3 and 4 | Plastic | (4) M8 * 1.25 | 6.77 | 60 |
| | Metal | (4) M8 * 1.25 | 6.77 | 60 |
| DC5 | Plastic | (6) M8 * 1.25 | 8.46 | 75 |
| | Metal | (6) M8 * 1.25 | 8.46 | 75 |
| DC6 | Plastic | (6) M8 * 1.25 | 8.46 | 75 |
| | Metal | (6) M8 * 1.25 | 8.46 | 75 |

6.2 Output Adjustment

All OMNI[®] pumps have a hand wheel for manual stroke adjustment. The hand wheel can be adjusted to any point from 0 to 100%. This value represents the stroke length setting and therefore the flow rate of the pump relative to its maximum output.

1. Turn the red lock screw counterclockwise to release the stroke lock. **Making adjustments without releasing the lock may damage the mechanism.**
2. Adjust the hand wheel to the desired output.
 - a) The stroke barrel indicates stroke length in 20% increments.
 - b) The hand wheel indicates stroke length in 1% increments.

For example, to set the pump to 75% stroke length, (starting from the factory default setting of 0%) turn the hand wheel counter clockwise until the 60% indicator is visible on the stroke barrel.

Continue the counter clockwise rotation until the hand wheel indicator is at 15. Refer to *Figure 4*.

3. Turn the lock screw clockwise to lock the stroke adjustment into position.

Adjustments can be made while the pump is at rest or operating, although adjustments are easier to make while the pump is in operation.

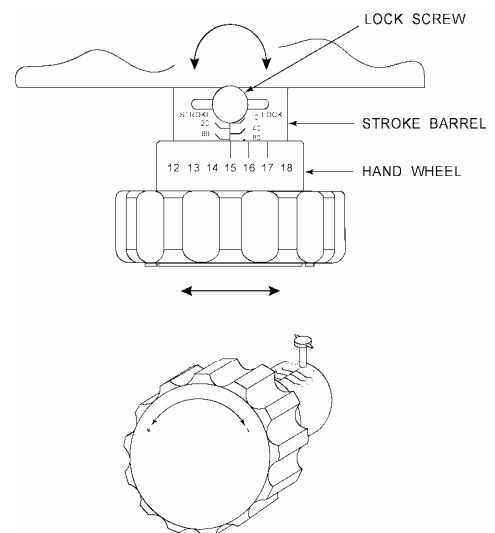

Figure 4, stroke adjustment

6.3 Priming the Reagent Head

1. When handling process liquids, follow all applicable personal and facility safety guidelines.
2. Ensure that the pump is ready for operation and that all process connections are secure.
3. Open the suction and discharge line shutoff valves.
4. If the piping system design and the storage tank are such that the product flows due to gravity through the pump, reduce the discharge pressure and the system will self prime when the pump is started. In the event the discharge line contains a significant amount of pressurized air or other gas, it may be necessary to lower the discharge pressure to enable the pump to self-prime.
5. If the installation involves a suction lift, it may be necessary to prime the reagent head and suction line. Operate the pump as in step 4 above, many times the pump will be capable of self priming. If it does not begin to pump, remove the discharge valve assembly. Carefully fill the reagent head through the discharge valve port with process (or compatible) liquid, and then reinstall the check valve.
6. Start the pump at the zero stroke length setting and slowly increase the setting to 100 to prime the pump. If this does not work, it will be necessary to fill the suction line.
7. Filling of the suction line will necessitate the use of a foot valve or similar device at the end of the suction line so that liquid can be maintained above the reservoir level. Remove the suction valve assembly, fill the line, replace the suction valve, then remove the discharge valve assembly and fill the reagent head as described in Step (3) above. The pump will now self-prime when started up per step (4) above. Use appropriate precautions if handling process fluid. Ensure that any other fluid used for priming is compatible with the product that will be pumped.

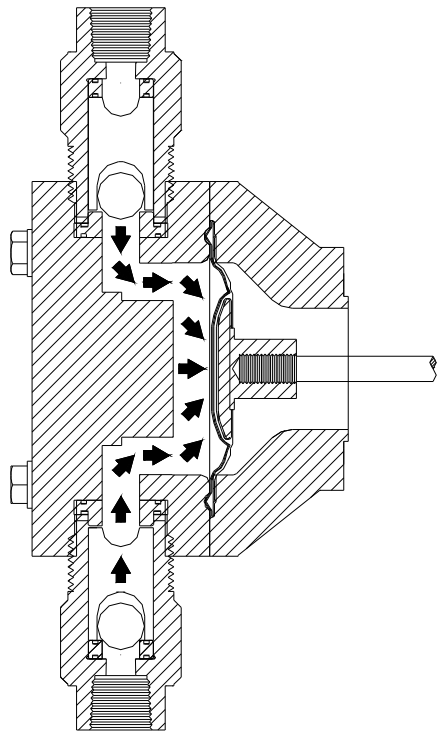

Figure 5, process flow

6.4 Calibration

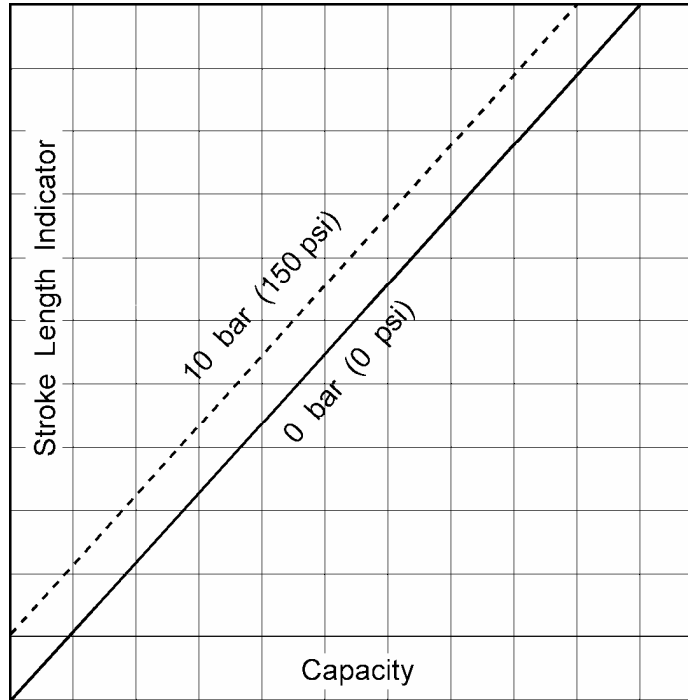

Figure 6, sample flow calibration curve

All metering pumps must be calibrated to accurately specify stroke length settings for required flow rates.

A typical calibration chart is shown above. Although output is linear with respect to stroke length setting, an increase in discharge pressure decreases output uniformly, describing a series of parallel lines, one for each pressure (only two are shown).

The theoretical output flow rate at atmospheric discharge pressure is based on the displacement of the diaphragm, stroke length and the stroking rate of the pump. With increasing discharge pressure there is a corresponding decrease in output flow. Pumps are rated for a certain flow at a rated pressure (check nameplate). Whenever possible, calibration should be performed under actual process conditions (i.e., the same or a similar process liquid at system operating pressure).

To construct a calibration chart, measure the flow rate several times at three or more stroke settings (i.e., 25, 50, 75, and 100), plot these values on linear graph paper, and draw a best-fit line through the points. For stable conditions, this line should predict settings to attain required outputs.

All users are encouraged to test the flow rate of their pump once installed in their system, to ensure best accuracy and reliable operation.

7. Maintenance



BEFORE PERFORMING ANY MAINTENANCE REQUIRING REAGENT HEAD OR VALVE (WET END) DISASSEMBLY, BE SURE TO RELIEVE PRESSURE FROM THE PIPING SYSTEM AND, WHERE HAZARDOUS PROCESS MATERIALS ARE INVOLVED, RENDER THE PUMP SAFE TO PERSONNEL AND THE ENVIRONMENT BY CLEANING AND CHEMICALLY NEUTRALIZING AS APPROPRIATE. WEAR PROTECTIVE CLOTHING AND EQUIPMENT AS APPROPRIATE.

Accurate records from the early stages of pump operation will indicate the type and levels of required maintenance. A preventative maintenance program based on such records will minimize operational problems. It is not possible to forecast the lives of wetted parts such as diaphragms and check valves. Since corrosion rates and operational conditions affect functional material life, each metering pump must be considered according to its particular service conditions.

The OMNI® KOPkit will contain all replacement parts normally used in a preventative maintenance program. It is recommended that KOPkits and PULSAube grease be kept available at all times.

7.1 Lubrication

OMNI® pumps are supplied completely lubricated from the factory. For optimum pump performance under normal conditions, gear grease should be redistributed every 1500 hours. For severe service in extreme temperatures or very dirty environments, this interval may be shorter.

1. Disconnect the power source to the drive motor, and relieve all pressure from the piping system.
2. Remove the side cover from the pump. Refer to *Figure 7*.
3. Redistribute grease onto gear and worm teeth. On DC2 and 3 pumps, force grease into the hole in the end of the gear shaft using a screwdriver or putty knife. Primary lubrication points are called out in *Figure 7*, below.
4. Replace the side gasket and cover.

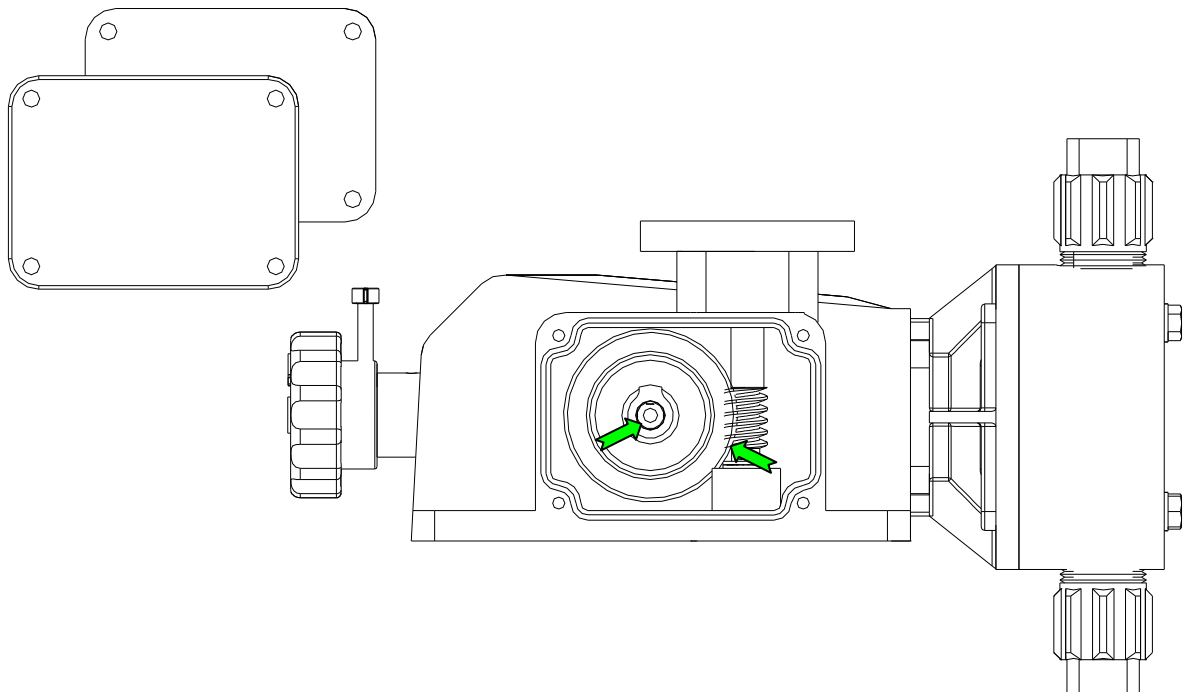
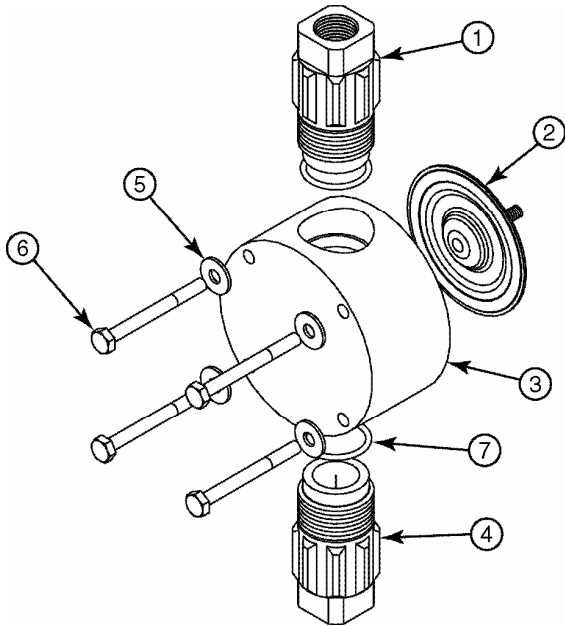

Figure 7, gearset lubrication points

7.2 Wet End Removal, Inspection, & Reinstallation



IF THE DIAPHRAGM HAS FAILED, PROCESS FLUID MAY HAVE CONTAMINATED THE PUMP ECCENTRIC HOUSING (ALTHOUGH NORMALLY, ANY PROCESS FLUID BEHIND A FAILED DIAPHRAGM WOULD PASS THROUGH THE BOTTOM DRAIN HOLE). HANDLE WITH APPROPRIATE CARE.



| Item | Description | Qty. |
|------|--------------------------------|------|
| 1 | Discharge Check Valve Assembly | 1 |
| 2 | Diaphragm | 1 |
| 3 | Reagent Head | 1 |
| 4 | Suction Check Valve Assembly | 1 |
| 5 | Flat Washer | 4 |
| 6 | Hex Head Bolt | 4 |
| 7 | O-Ring | 2 |

Figure 8, wet end components

OMNI[®] diaphragms do not have a specific cycle life; however, the accumulation of foreign material or debris sufficient to deform the diaphragm can eventually cause failure. Failure can also occur as a result of system over pressure or chemical attack. Periodic diaphragm inspection and replacement are recommended. Each user should perform regular inspections to determine the replacement interval that is appropriate to their system conditions.

7.2.1 Diaphragm Removal & Reinstallation

1. Adjust the stroke setting to 50% and disconnect the power source to the drive motor.
2. Relieve all pressure from the piping system.

Take all precautions described under the **WARNING** on page 9, *Section 7* to prevent environmental damage and exposure of personnel to hazardous materials.

3. Close the inlet and outlet shutoff valves.
4. Place a pan underneath the pump head adaptor to catch any liquid leakage.
5. Disconnect piping to the reagent head and drain any process liquid, following material safety precautions described.
6. Remove all but one top reagent head bolt. Product will leak out between the pump head adaptor and reagent head as the bolts are loosened.
7. Tilt the head and pour out any liquids retained by the check valves into a suitable container, continuing to follow safety precautions as appropriate.
8. Remove the final bolt and rinse or clean the reagent head with an appropriate material.
9. Remove the diaphragm by turning it counter-clockwise.
10. Inspect the diaphragm. The diaphragm must be replaced if it is cracked, separated, or obviously damaged.
11. Install the diaphragm.
 - a) Ensure that the critical sealing areas of diaphragm, reagent head, and pump head are clean and free of debris.
 - b) Lubricate the elastomer side of the diaphragm liberally, where it is in contact against the pump head and deflection plate. Use a silicone grease or silicone-based o-ring lubricant.
12. Thread the diaphragm (clockwise) fully onto the shaft.

When reinstalling a used diaphragm it is not necessary to maintain the previous orientation relative to the reagent head or pump head hole pattern.
13. Install the reagent head bolts and tighten in an alternating pattern to ensure an even seating force. Torque to the values recommended in *Section 6.1*.
14. Re-prime the pump following the procedure outlined in *Section 6.3*.

7.3 Check Valves

7.3.1 General Description

Most fluid metering problems are related to check valves. Problems usually stem from solids accumulation between valve and seat, corrosion of seating surfaces, erosion, or physical damage due to wear or the presence of foreign objects.

The valve incorporates a ball, guide, and seat. Flow in the unchecked direction lifts the ball off the seat, allowing liquid to pass through the guide. Reverse flow forces the ball down, sealing it against the sharp edge of the seat. The guide permits the ball to rotate but restricts vertical and lateral movement in order to minimize “slip” or reverse flow. Ball rotation prolongs life by distributing wear over the entire surface of the ball. Since ball return is by gravity, the valve must be in the vertical position in order to function properly. Parts are sealed by “O”-rings.

All OMNI models with the exception of the DC5 and 6 in metal construction utilize a convenient cartridge-type check valve. All check components are pre-assembled and the cartridge should be replaced as a unit. When replacing, note that valves are marked with the flow direction, as the suction and discharge configurations are different.

OMNI DC5 and 6 models supplied with metal (316ss) reagent head construction utilize a multi-part check valve assembly, secured to the reagent head with a tie-bar clamping arrangement. These utilize the same components (seat, ball, and guide) and operate in the same manner as the cartridge type.

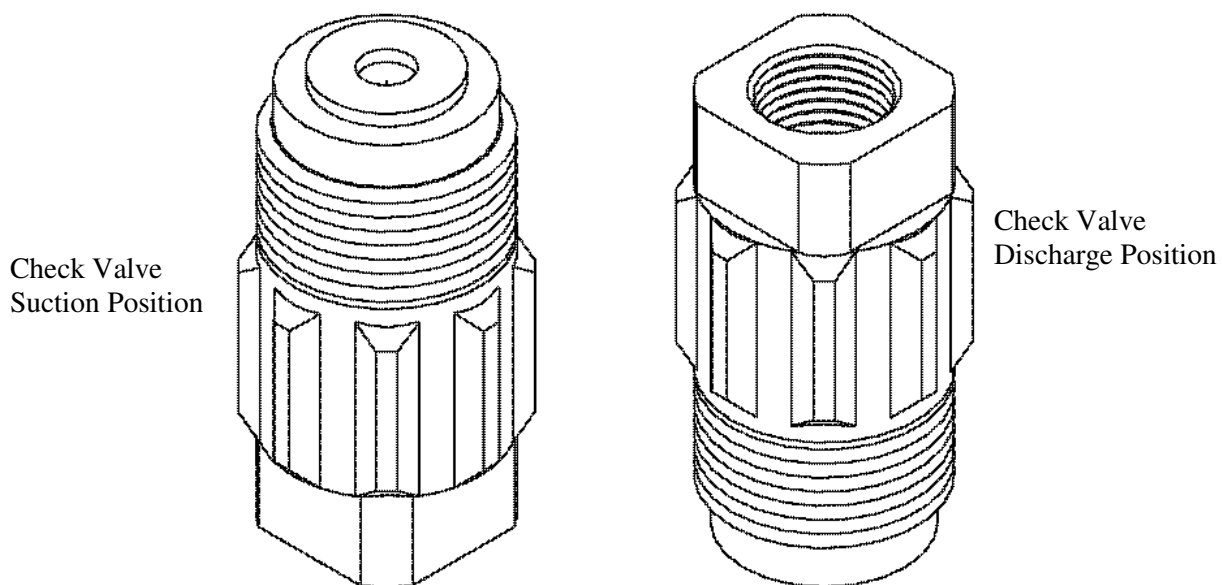

Figure 9, check valves DC2

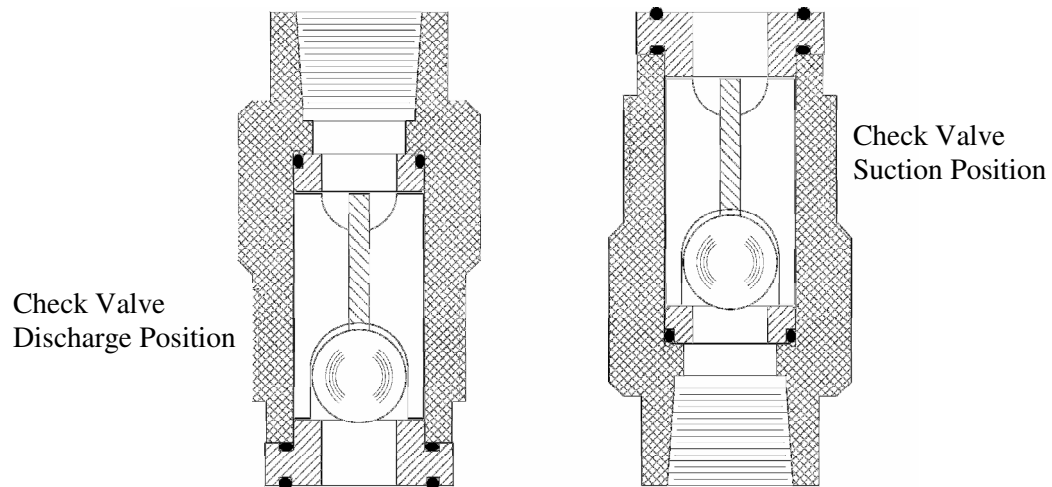

Figure 10, check valves, DC3 and DC 4

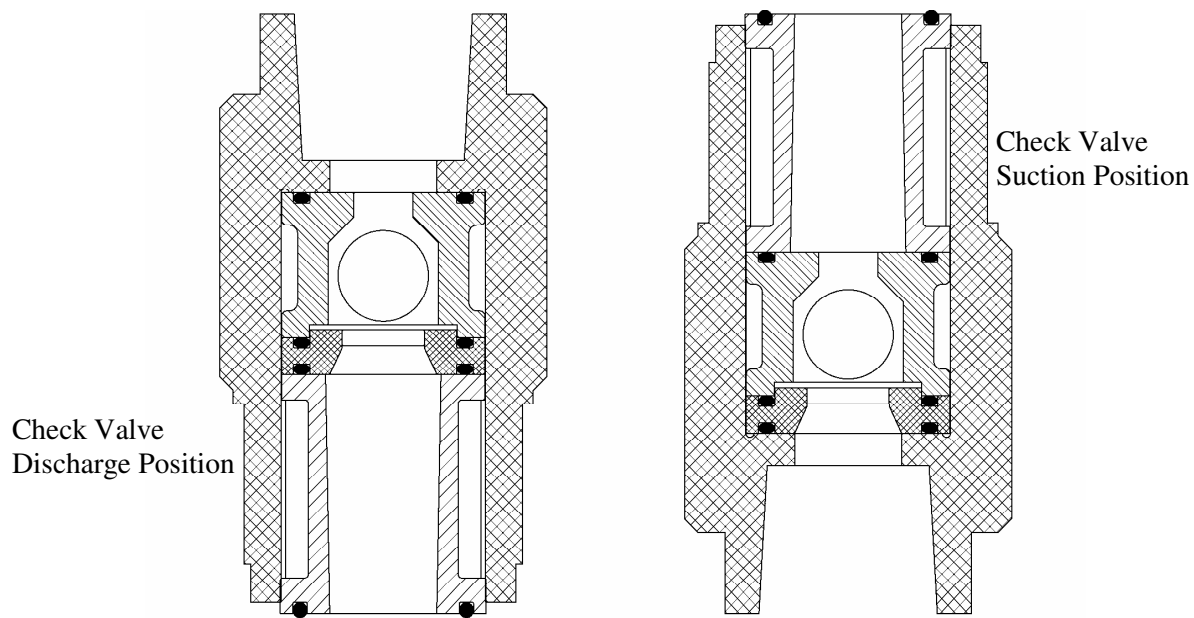

Figure 11, check valves, DC5 and DC6 plastic construction

7.3.2 Check Valve Removal & Reinstallation, Cartridge type



Valving that is of the cartridge design is intended to be replaced as an assembly.

15. Disconnect the power source to the drive motor.
16. Relieve all pressure from the piping system.
17. Take all precautions necessary to prevent contamination to the environment and personnel exposure to hazardous materials.
18. Close the inlet and outlet shutoff valves.
19. Disconnect the suction piping at the installed union near the suction port.
20. Loosen and remove the suction valve cartridge slowly to drain any liquid from the reagent head.
21. Disconnect the discharge piping at the installed union near the discharge port.
22. Loosen and remove the discharge valve cartridge slowly to drain any trapped liquid.
23. Reinstall both new valve assemblies, taking care to ensure that they are in the correct ports.



Lettering on the side of each valve should be right side up when assembled to the pump. Each valve assembly should also have an arrow, which should indicate direction of flow (upwards). Do not coat the threads of the cartridge valve with a pipe sealant. Each valve cartridge should be tightened only until the o-ring seal makes good contact with the reagent head surface. Over-tightening will cause damage and lead to leaks

24. Reinstall both suction and discharge piping. Secure the cartridge while making your external connections to prevent rotating the cartridge and over-tightening it into the pump.

7.3.3 Check Valve Removal & Reinstallation, Tie-bar type

1. Disconnect the power source to the drive motor.
2. Relieve all pressure from the piping system.
3. Take all precautions necessary to prevent contamination to the environment and personnel exposure to hazardous materials.
4. Close the inlet and outlet shutoff valves.
5. Loosen the suction valve tie-bar bolts (4) and spring the suction piping slightly away from the head, allowing liquid to drain. It may be necessary to loosen a union or flange.
6. Remove the suction check valve assembly by sliding it towards you, holding it together as a unit. Note carefully the position of the component parts, to assist in re-assembly.
7. Loosen the discharge valve tie-bar bolts (4) and spring the discharge piping slightly away from the head, allowing liquid to drain. It may be necessary to loosen a union or flange.
8. Remove the discharge check valve assembly by sliding it towards you, holding it together as a unit. Note carefully the position of the component parts, to assist in re-assembly.
9. Disassemble both valves and check components for wear or damage. The seats should have a sharp edge and be free from dents or nicks. Hold a ball firmly against the seat in front of a bright light and inspect for fit, observation of light between the ball and seat is cause for replacement.
10. Reassemble both valves using new parts as required. Sealing o-rings should always be replaced.
11. Replace both valve assemblies onto the pump, taking care to ensure they are oriented correctly, with the balls above the seats, and the seats oriented with the sharp edge up and the chamfered edge down.



Inserting the check valve assembly into the pump in the wrong direction, or having the check seat upside down, will prevent proper seals at the o-rings, decrease pump performance, and can cause damage to the diaphragm.

- Carefully make sure that the check assemblies are in proper position, and tighten the four tie-bar bolts, using a star pattern, to a torque of 6 Ft-lbs (8 N-m).
- Retighten any unions, flanges, or other process connections that may have been loosened previously.

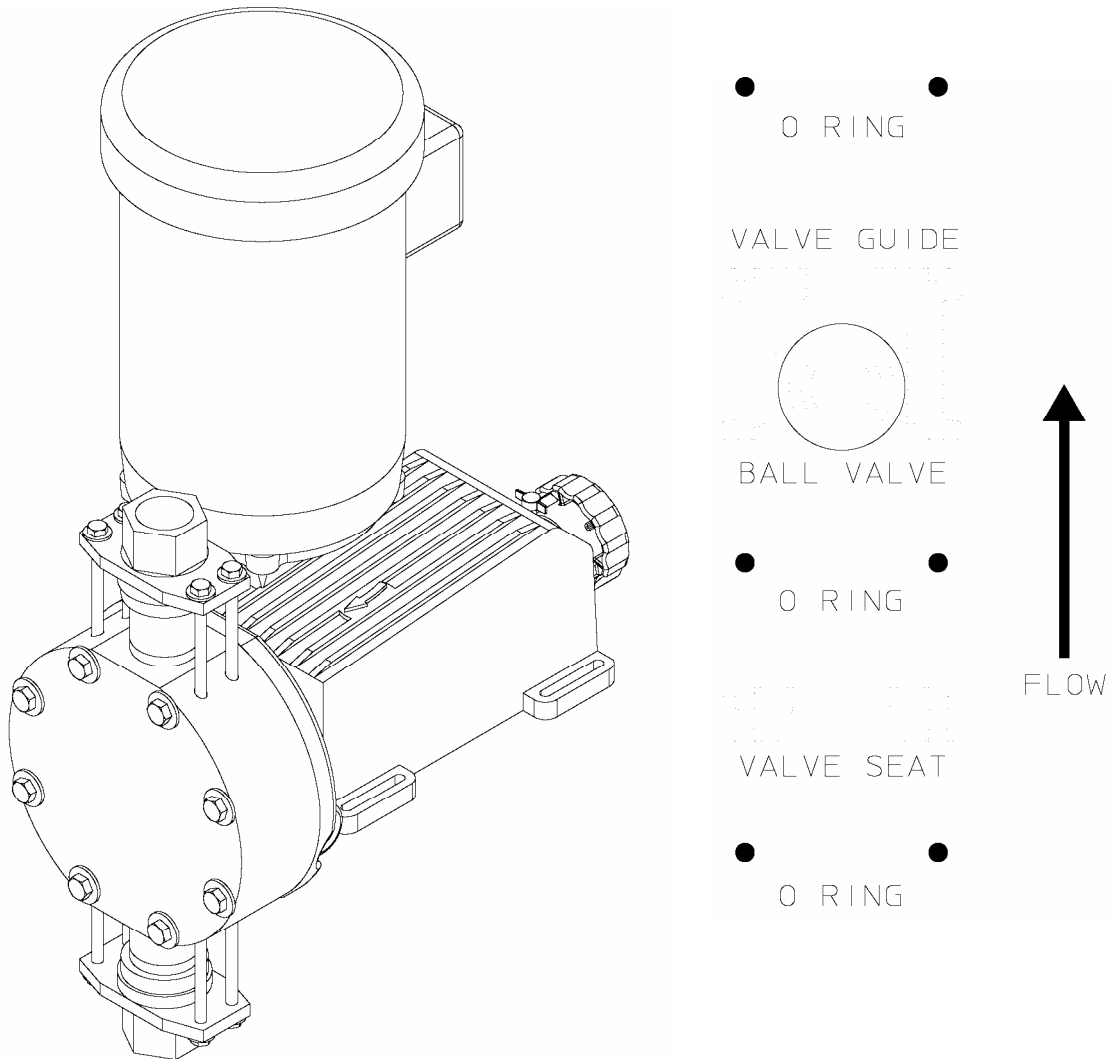

Figure 12, DC5 and 6 check valves, metal construction

7.4 Motor Removal & Reinstallation

1. Disconnect the power source to the drive motor.
2. Disconnect the motor wiring from the motor.
3. Remove the four bolts retaining the motor to the motor adaptor.
The motor shaft fits into a bore on the pump input shaft.
4. Slide the motor shaft out of the pump input shaft.
Be careful not to lift the pump input shaft up out of the pump.
5. Apply a lubricant such as Loctite™ Silver Grade® Anti-seize paste (or similar) to the motor shaft and key before reassembling..
6. Reinstall the motor by sliding the motor shaft into the pump input shaft.
7. Insert and tighten the four bolts removed in step 3.
8. Reconnect the motor wiring to the motor.
9. Connect power to the drive motor.

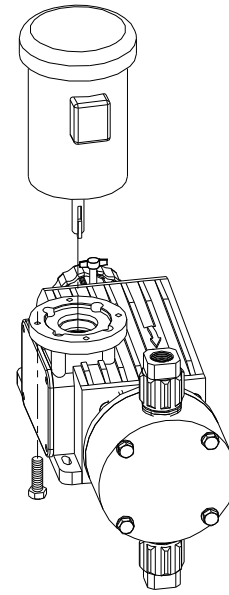

Figure 13, motor mounting



Motor rotation must be wired for CW rotation, as viewed from the top of the motor, as noted by the arrow on the top of the pump housing.

7.5 Gearset Removal

Gearset diagram is on following page

1. Disconnect power source and wiring from the motor.
2. Set stroke adjustment to zero.
3. Remove motor from the pump (refer to **Section 7.4**).
4. Remove the four socket head screws (Item 1) that attach the motor adaptor (Item 2) to the pump housing and remove the adaptor.
5. Loosen and remove the Hex Head Bolts (Item 5), and remove the pump side cover (Item 6) and gasket (Item 7).
6. Remove the Worm Shaft Assembly (item 4) by carefully pulling it straight up out of the pump housing. On DC2 and DC3 models, be careful not to lose the lower thrust bearing and washers (items 11 and 12).

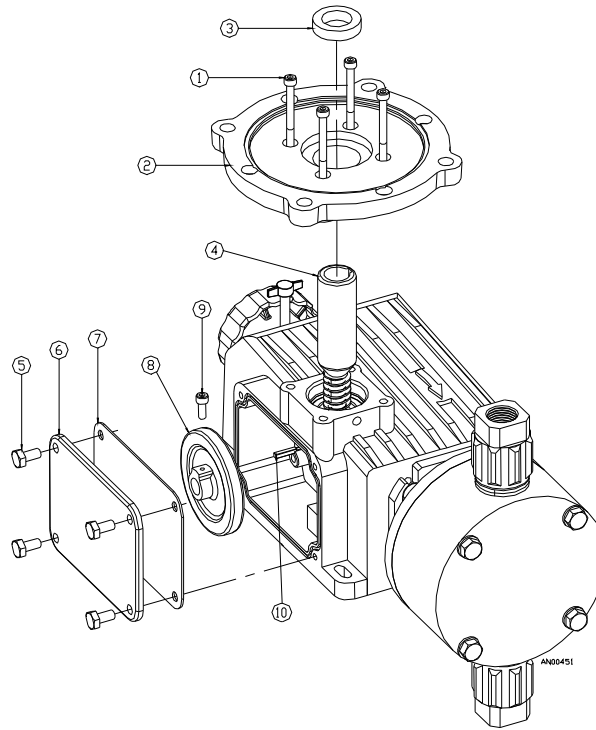
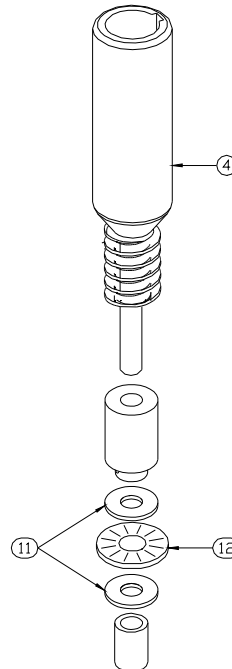

Figure 14, gearset components

7. Loosen the set screw (Item 9) on the worm gear (Item 8) and remove it along with its shaft key (Item 10).

If you have the **DC2 or 3 models** go to step 8. If you have the **DC4, 5, or 6 models** go to step 9.

8. Remove the Thrust Washers and Bearing (Item 11 & 12) from the housing.
If the Thrust Washers show signs of excessive wear or scoring, replace them during re-assembly.
9. Clean grease from the gear cavity.
10. Examine the Worm Shaft Grease Seal (Item 3) in the pump housing on the DC 2 and 3 model or in the motor adaptor on the DC 4, 5, and 6 models.
If the Grease Seal shows excessive wear or damage, replace it during re-assembly.



| ITEM | DESCRIPTION | QTY. |
|------|------------------|------|
| 4 | WORM SHAFT ASS'Y | 1 |
| 11 | THRUST WASHER | 2 |
| 12 | THRUST BEARING | 1 |

Figure 15, worm shaft

7.6 Gearset Replacement

1. Apply *PULSA*lube grease # NP980006-000 to both sides of the thrust washer and install onto the eccentric shaft.
On the DC4, 5, and 6 models, the washer fits into a shallow counter-bore.
2. Assemble Worm Gear (Item 8) and key (Item 10) to the eccentric shaft. Do not tighten the setscrew yet.
3. Thread the M6-1.0 screw into the threaded hole in the end of the eccentric shaft. Tighten the Worm Gear set screw while simultaneously pulling on the screw in the end of the shaft in order to eliminate any endplay in the eccentric shaft.
4. Rotate the Worm Gear
It should turn easily with no perceptible endplay.
5. Remove the screw that was inserted in the shaft in step 3.
6. Assemble and install the worm shaft assembly
 - a) If you have a DC2 or 3 model:
Apply *PULSA*lube grease # NP980006-000 to the two lips of the worm shaft seal.
Apply *PULSA*lube grease # NP980006-000 to the small end of the worm shaft.
Carefully insert the worm shaft into the pump housing.
Assemble the lower thrust bearing (with a washer on each side) into the shallow counter bore in the bottom of the housing cavity.
Fit the shaft into the bearing in the housing.
 - b) If you have a DC4, 5, or 6 model:
Apply *PULSA*lube grease # NP980006-000 to the small end of the worm shaft.
Insert the worm shaft into the pump housing, fitting the end of the shaft into the bearing in the housing.
Apply *PULSA*lube grease # NP980006-000 to the two lips of the seal.
Assemble the adapter to the pump housing while carefully slipping the seal over the worm shaft.
7. Fill the gear cavity completely with *PULSA*lube grease # NP980006-000 and reassemble the pump side cover and gasket.
8. Reassemble the motor to the pump. Verify that motor rotation is clockwise when viewed from the top.
9. Reinstall the pump in the system and restart the pump (refer to **Section 6 – Startup**).

8. Replacement Parts

8.1 KOPkit Program

OMNI® KOPkits contain all replacement parts normally used in a preventative maintenance program. (*PULSAlube* grease is also available separately for preventative maintenance programs. Refer to *Section 6 – Equipment Startup*). There is a specific KOPkit for every OMNI® pump model. Each KOPkit is vacuum-packed for extended storage. All OMNI® pumps have the KOPkit number identified on the pump nameplate and Pulsafeeder order documents. KOPkits can also be selected from the technical data sheet shipped with the pump or by a Pulsafeeder representative. A list of the OMNI KOPkit numbers can also be found on the next page. The kit is identified by the model number of the pump, the wetted end material, and the process connection thread type. For models with tie-bar type check valves, the appropriate components (check valve balls, seats, and o-rings) are supplied instead of the cartridges pictured.

Kit Contains:

- 1 Diaphragm Assembly
- 1 Suction Valve Cartridge
- 1 Discharge Valve Cartridge

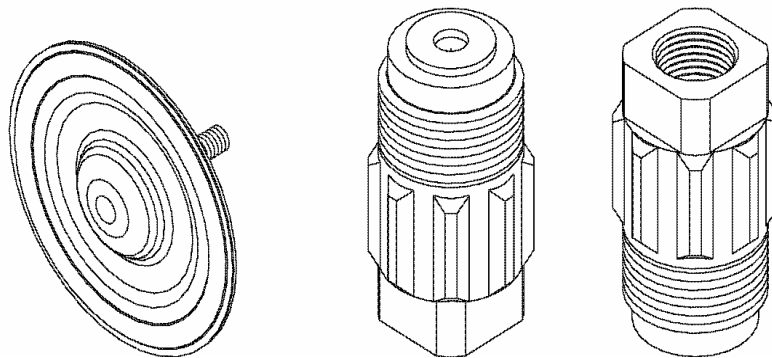

Figure 16, KOPkit parts

8.2 Ordering KOPkits or Parts

When ordering replacement parts always specify:

- Pump model and serial number (from pump nameplate), e.g., Model No. (DC-2) with Serial No. F406365-3.
- Part number and description from the OMNI® parts list. Include the three-character suffix. (Note: OMNI part numbers begin either with the letters **NP**, or the letter **W**, e.g., NP170001-THY or W210221-001.)

8.3 KOPkit numbers by model:

| Pump Model | Wetted Material | Connection Type | KOPkit number |
|------------|--------------------|-----------------|-------------------------|
| DC2 | PVDF | NPT | NLK020FP |
| DC3 or DC4 | PVDF | NPT | NLK040FP |
| DC3 or DC4 | PVDF | ISO 7-1 | NLK040FB |
| DC5 or DC6 | PVDF | NPT | NLK050FP |
| DC5 or DC6 | PVDF | ISO 7-1 | NLK050FB |
| DC7 | PVDF | n/a | NLK070FX |
| DC5 or DC6 | Polypropylene | NPT | NLK050PP |
| DC5 or DC6 | Polypropylene | ISO 7-1 | NLK050PB |
| DC7 | Polypropylene | n/a | NLK070PX |
| DC2 | 316 | NPT | NLK020AP |
| DC3 or DC4 | 316 | NPT | NLK040AP |
| DC3 or DC4 | 316 | ISO 7-1 | NLK040AB |
| DC5 or DC6 | 316 | NPT | NLK050AP |
| DC5 or DC6 | 316 | ISO 7-1 | NLK050AB |
| DC6 | HSO ⁽²⁾ | NPT | NLK060HX ⁽¹⁾ |
| DC6 | HSO ⁽²⁾ | ISO 7-1 | NLK060HX ⁽¹⁾ |

NOTES:

(1) “HSO” construction refers to the recommended materials for handling Sulfuric Acid at high concentrations (above 95%). This configuration consists of 316ss for the reagent head, the valve guide, and the process connection. Alloy-20 is supplied for the check valve seats, and Hastelloy-C is supplied for the check valve balls. ***HSO configuration is supplied only as a KOPkit and not as an original pump configuration.***

(2) PVC wet end material has been discontinued, use PVDF (Kynar[®]) parts as a direct replacement for these pumps.

(3) DC7 model is covered in a separate publication

9. Model Number Identification

| Position | Sample | Specifies | Options |
|----------|----------|----------------------|---|
| 1 and 2 | DC | | DC = OMNI model pump |
| 3 and 4 | 3B | Size/Flow | 2 / 3 / 4 / 5 / 6 – diaphragm diameter A / B / C / D – stroking rate See sales literature for flow/pressure ratings |
| 5 | X | Motor frame and size | 1 – ½ Hp, 1 pH 115/230V, 71 frame 2 – ½ Hp, 1 pH, 115/230V, 56 frame 3 – ½ Hp, 3 pH, 230/380V, 71 frame 4 – ½ Hp, 3 pH, 230/380/460V, 56 frame 5 – MPC control with 56 frame motor 6 – MPC control, NO motor, 56 frame 7 – MPC control with 71 frame motor 8 – MPC control, NO motor, 71 frame X – no motor, set up for 56 frame Y – no motor, set up for 71 frame |
| 6 | F | Wetted materials | F – PVDF, PTFE o-rings, ceramic ball E – PVC (note - obsolete) A – 316ss, PTFE o-rings P - Polypropylene, DC 5 and 6 only |
| 7 | P | Connections | P – NPT B – ISO 7-1 (not available on DC2) |
| 8 | - * | | position 8 is a dash |
| 9 | Option * | MPC control | M – indicates supplied with MPC controller |
| 10 | Option * | Input voltage | 1 – 115V 60 Hz 2 – 230V 60 Hz 3 – 110V 50 Hz 4 – 220V 50 Hz |
| 11 | Option * | Remote cable | X – standard length remote at pump C – extended cable length |
| 12 | Option * | Language | E – English F - French S - Spanish G - German |

* - If no MPC controller is ordered, the model string ends at position 7. Positions 8 through 12 are not entered for a pump without the MPC.

10. Wet End Materials Reference

| Wet End Configuration | Model | Connection | Head | Guide | Sealing O-rings | Balls | Seats | Seat O-ring | | |
|-------------------------------|-------|--|------|-------|-----------------|---------|--------------------|-----------------------|--|-------|
| PVDF (Kynar®) | DC2 | 1/4" NPT | PVDF | PVDF | PTFE | Ceramic | PVDF | n/a | | |
| | DC3 | 1/2" NPT or ISO 7-1 | | | | | | | | |
| | DC4 | | | | | | | | | |
| | DC5 | | | | | | | | | |
| | DC6 | 1" NPT or ISO 7-1 | | | | | | | | |
| | DC7 | 1 1/2" NPT & ANSI Flange and 1 1/2" DIN40 Flange | | | Viton® | | PVDF (o-ring seat) | Viton® ⁽¹⁾ | | |
| PP (Polypropylene) | DC2 | n/a | n/a | | | | | | | |
| | DC3 | | | | | | | | | |
| | DC4 | | | | | | | | | |
| | DC5 | 1" NPT or ISO 7-1 | PP | PP | PTFE | Ceramic | PP | n/a | | |
| | DC6 | | | | | | | | | |
| | DC7 | | | | | | | | 1 1/2" NPT & ANSI Flange and 1 1/2" DIN40 Flange | Viton |
| SS (316) | DC2 | 1/4" NPT | | | SS | SS | PTFE | Ceramic | PTFE | n/a |
| | DC3 | 1/2" NPT or ISO 7-1 | | | | | | SS | SS | |
| | DC4 | | | | | | | | | |
| | DC5 | | | | | | | | | |
| | DC6 | 1" NPT or ISO 7-1 | | | | | | | | |
| | DC7 | n/a | n/a | | | | | | | |

(1) DC7 check valve seats incorporate an o-ring seal

DC7 model is covered in a separate publication

n/a = materials not available in this pump size or component not used on this model

11. Troubleshooting

| Difficulty | Probable Cause | Remedy |
|------------------------------------|--|--|
| Pump does not start | Faulty power source. | Check power source. |
| | Blown fuse, circuit breaker. | Replace - eliminate overload. |
| | Broken wire. | Locate and repair. |
| | Wired improperly. | Check diagram. |
| | Process piping blockage. | Open valves, clear other obstructions. |
| No delivery | Motor not running. | Check power source. Check wiring diagram (see above). |
| | Supply tank empty. | Fill tank. |
| | Lines clogged. | Clean and flush. |
| | Closed line valves. | Open valves. |
| | Ball check valves held open with solids. | Clean – inspect, flush with clear fluid. |
| | Vapor lock, cavitation. | Increase suction pressure. |
| | Prime lost. | Re-prime, check for leak. |
| | Strainer clogged. | Remove and clean. Replace screen if necessary. |
| Low delivery | Stroke adjustment set at zero. | Increase stroke length setting. |
| | Motor speed too low | Check voltages, frequency, wiring, and terminal connections. Check nameplate vs. Specifications. |
| | Check valves worn or dirty | Clean, replace if damaged |
| | Calibration system error | Evaluate and correct |
| | Product viscosity too high | Lower viscosity by increasing product temperature or dilution. Increase pump and/or piping size |
| Delivery gradually drops. | Product cavitating | Increase suction pressure. |
| | Check valve leakage. | Clean, replace if damaged. |
| | Leak in suction line. | Locate and correct. |
| | Strainer fouled. | Clean or replace screen. |
| | Product change. | Check viscosity and other variables. |
| Delivery erratic. | Supply tank vent plugged. | Unplug vent. |
| | Leak in suction line. | Locate and correct. |
| | Product cavitating. | Increase suction pressure. |
| | Entrained air or gas in product. | Consult factory for suggested venting. |
| | Motor speed erratic. | Check voltage and frequency. |
| | Fouled check valves. | Clean, replace if necessary. |
| | Inadequate backpressure | Increase discharge pressure to obtain a minimum pressure difference of 5 pis from suction to discharge |
| Delivery higher than rated. | Suction pressure higher than discharge pressure. | Install backpressure valve or consult factory for piping recommendations. |
| | Back pressure valve set too low. | Increase setting. |
| | Back pressure valve leaks. | Repair, clean, or replace. |

| Difficulty | Probable Cause | Remedy |
|--------------------------------|--|---|
| Noisy gearing, knocking | Discharge pressure too high. | Reduce pressure. |
| | Water hammer. | Install pulsation dampener. |
| | Stroke length at partial setting. | Some operating noise is characteristic of lost motion pumps. |
| | Low grease level. | Add or replace grease. |
| Piping noisy. | Pipe size too small. | Increase size of piping - install pulsation dampener. |
| | Pipe runs too long. | Install pulsation dampener in line. |
| | Pulsation dampener inoperative or flooded. | Refill with air or inert gas. Inspect and replace diaphragm and recharge. |
| | No surge chamber or dampener used. | Install pulsation dampeners. |
| Motor overheats. | Pump overloaded. | Check operating conditions against pump design. Verify discharge pressure |
| | High or low voltage. | Check power source. |
| | Loose wire. | Trace and correct. |
| | Incorrect motor wiring | Verify and correct |

12. Piping Accessories

Pressure Relief Valves

Pressure relief valves are designed to protect chemical feed systems from damage that may be caused by defective equipment or a blockage in the discharge line. These valves function to limit the pressure downstream of the pump. Field adjust the pressure relief valve to operate when the discharge pressure exceeds operating pressure by 10-15%. Pressure relief valve should always be adjusted to a setting below the maximum rated pressure of the pump. No potentially restrictive components, such as a valve, should be installed between the pump discharge and the PRV.

Diaphragm Backpressure Valve

A diaphragm backpressure valve creates constant back pressure. A PTFE or PTFE-faced diaphragm offers maximum chemical protection and service life, and seals spring and bonnet from product.

Be sure to install with fluid flow in direction of arrow on valve body.

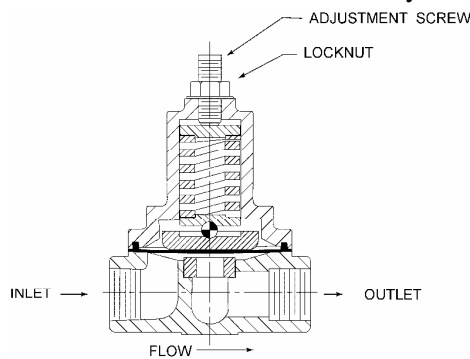

Pulsation Dampener

A pulsation dampener is a pneumatically charged diaphragm-type chamber that intermittently stores hydraulic energy. Used on the inlet, it can improve NPSHA (Net Positive Suction Head available) characteristics of the suction piping system. On the discharge line it will reduce discharge pressure and pulsating flow variations.

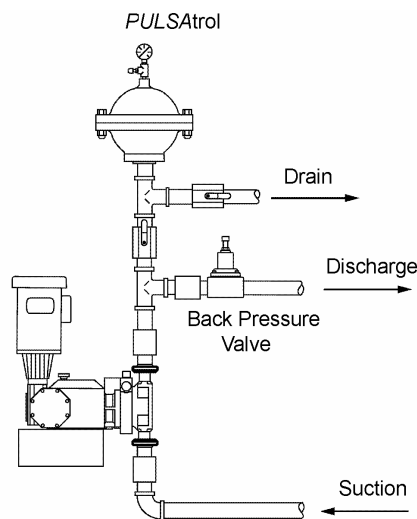

DISCHARGE INSTALLATION

13. Dimensional Drawing

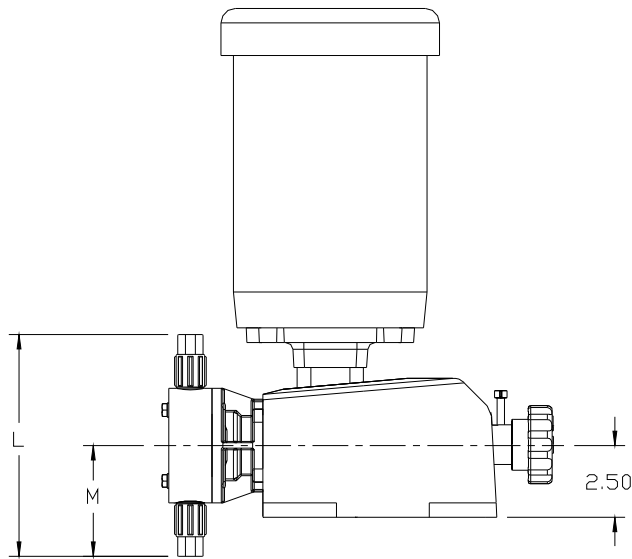
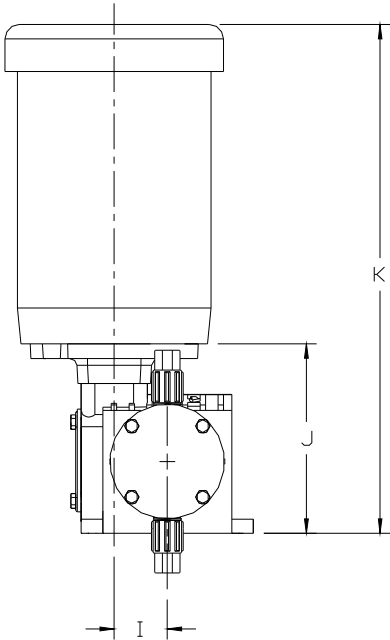
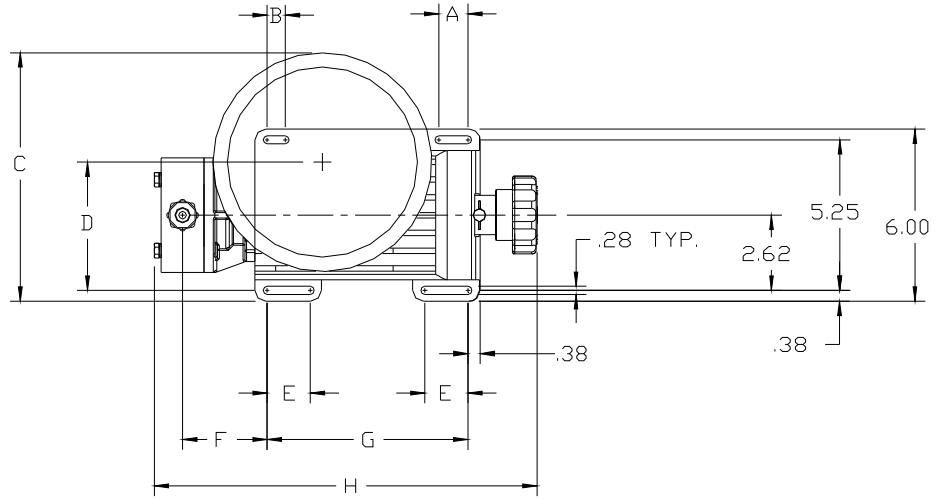

Letters reference dimensional table on next page

Dimension table in inches / mm

Letter references to diagram, previous page

“PP” = Polypropylene wetted material

“SS” = Stainless steel wetted material

Dimensions are with standard IEC 71 B14 frame motor

| Model | Dimension | | | | |
|---------------|------------|------------|-------------|-------------|------------|
| | A | B | C | D | E |
| DC2 | 1.0 / 25.4 | 0.7 / 18.0 | 6.9 / 175.3 | 4.5 / 113.5 | 1.5 / 38.1 |
| DC3 | 1.0 / 25.4 | 0.7 / 18.0 | 6.9 / 175.3 | 4.5 / 113.5 | 1.5 / 38.1 |
| DC4 | 2.0 / 50.8 | 0.9 / 22.4 | 7.6 / 193.0 | 5.1 / 130.2 | 1.8 / 44.5 |
| DC5 – PP/PVDF | 2.0 / 50.8 | 0.9 / 22.4 | 7.6 / 193.0 | 5.1 / 130.2 | 1.8 / 44.5 |
| DC5 – SS | 2.0 / 50.8 | 0.9 / 22.4 | 7.6 / 193.0 | 5.1 / 130.2 | 1.8 / 44.5 |
| DC6 – PP/PVDF | 2.0 / 50.8 | 0.9 / 22.4 | 7.6 / 193.0 | 5.1 / 130.2 | 1.8 / 44.5 |
| DC6 - SS | 2.0 / 50.8 | 0.9 / 22.4 | 7.6 / 193.0 | 5.1 / 130.2 | 1.8 / 44.5 |

| Model | Dimension | | | | |
|---------------|------------|-------------|--------------|------------|-------------|
| | F | G | H | I | J |
| DC2 | 2.9 / 72.4 | 7.4 / 188.7 | 13.6 / 347.6 | 1.8 / 46.7 | 5.7 / 145.3 |
| DC3 | 3.3 / 83.6 | 7.4 / 188.7 | 14.6 / 370.2 | 1.8 / 46.7 | 5.7 / 145.3 |
| DC4 | 3.4 / 85.5 | 8.4 / 213.9 | 15.4 / 392.4 | 2.5 / 63.5 | 6.9 / 175.5 |
| DC5 – PP/PVDF | 3.6 / 90.4 | 8.4 / 213.9 | 15.8 / 402.0 | 2.5 / 63.5 | 6.9 / 175.5 |
| DC5 – SS | 3.6 / 90.4 | 8.4 / 213.9 | 15.8 / 402.0 | 2.5 / 63.5 | 6.9 / 175.5 |
| DC6 – PP/PVDF | 3.6 / 90.4 | 8.4 / 213.9 | 15.8 / 402.0 | 2.5 / 63.5 | 6.9 / 175.5 |
| DC6 - SS | 3.6 / 90.4 | 8.4 / 213.9 | 15.8 / 402.0 | 2.5 / 63.5 | 6.9 / 175.5 |

| Model | Dimension | | |
|---------------|--------------|--------------|-------------|
| | K | L | M |
| DC2 | 14.5 / 367.5 | 7.7 / 196.3 | 3.9 / 98.2 |
| DC3 | 14.5 / 367.5 | 8.9 / 226.1 | 4.5 / 113.0 |
| DC4 | 15.7 / 397.8 | 8.9 / 226.1 | 4.5 / 113.0 |
| DC5 – PP/PVDF | 15.7 / 397.8 | 13.8 / 350.5 | 6.9 / 175.3 |
| DC5 – SS | 15.7 / 397.8 | 12.6 / 320.0 | 6.3 / 160.0 |
| DC6 – PP/PVDF | 15.7 / 397.8 | 15.3 / 387.3 | 7.6 / 193.7 |
| DC6 – SS | 15.7 / 397.8 | 14.1 / 356.9 | 7.1 / 178.5 |

14. Parts Diagrams and Parts Lists

14.1 Parts diagram, DC2 and 3

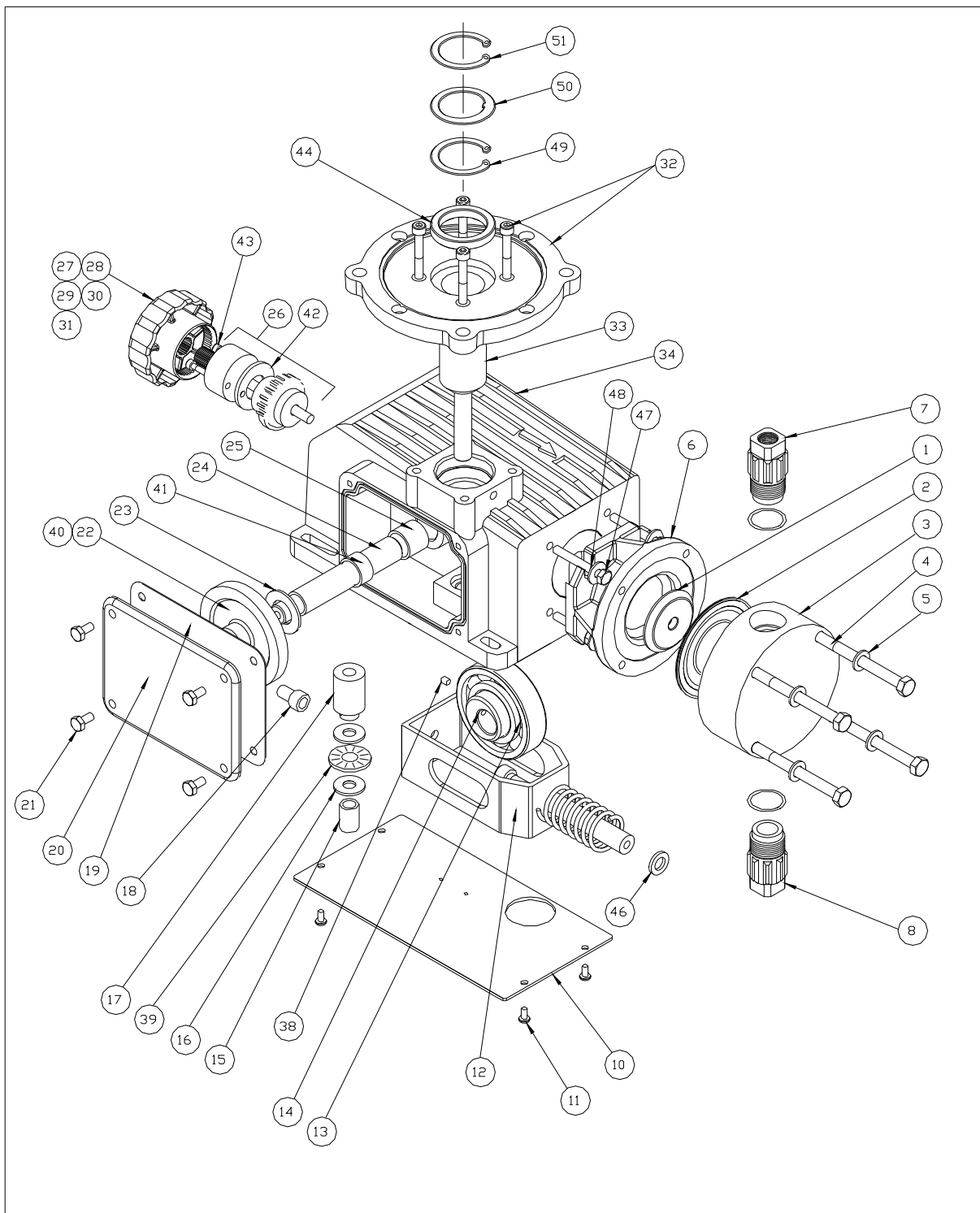

ALL DIMENSIONS ARE IN INCHES



DC2/3 MECHANICAL
PUMP ISOMETRIC

| | | | | | |
|--------------|--------------------------|----------|--|----------------|--|
| SECTION/PAGE | | DMNI/100 | | DWN BY: JRY | |
| EFFECTIVE | | 02/15/05 | | DATE: 09/24/04 | |
| SUPERSEDES | | 11/17/04 | | AN00452-000 | |
| △ | ECN# A300 REV'D ITEM 7/8 | 02/15/05 | | | |
| REF | REVISION UPDATE | DATE | | | |

14.2 Bill of Materials, DC2

| ITEM | DESCRIPTION | QTY | PART NUMBER |
|------|----------------------------------|-----|--------------|
| 1 | SUPPORT PLATE | 1 | NP140054-BRS |
| 2 | DIAPHRAGM | 1 | NP170030-THY |
| 3 | REAGENT HEAD PVDF | 1 | NP160076-PVD |
| 3 | REAGENT HEAD PVC (obsolete) | 1 | NP160054-PVC |
| 3 | REAGENT HEAD 316 | 1 | NP160054-316 |
| 4 | BOLT | 4 | NP990420-188 |
| 5 | FLT WASHER | 4 | NP991017-188 |
| 6 | DC2 SPOOL ADAPTOR | 1 | NP140067-ALU |
| 7 | VLV ASSY PVDF NPT DISCHARGE | 1 | L3200TC4-PVD |
| 7 | VLV ASSY PVC NPT DISCHARGE (obs) | 1 | L3200TC4-PVC |
| 7 | VLV ASSY 316 NPT DISCHARGE | 1 | L3200TC4-316 |
| 8 | VLV ASSY PVDF NPT SUCTION | 1 | L3100TC4-PVD |
| 8 | VLV ASSY PVC NPT SUCTION (obs) | 1 | L3100TC4-PVC |
| 8 | VLV ASSY 316 NPT SUCTION | 1 | L3100TC4-316 |
| 9 | RETURN SPRING | 1 | NP430033-000 |
| 10 | BOTTOM COVER | 1 | NP250084-000 |
| 11 | BOTTOM COVER SCREW | 4 | NP992216-STL |
| 12 | STRADDLE ASSEMBLY | 1 | NP410066-000 |
| 13 | BEARING | 1 | NP400037-000 |
| 14 | ECCENTRIC | 1 | NP070022-000 |
| 15 | BEARING | 1 | NP400041-000 |
| 16 | THRUST WASHER | 2 | NP470033-000 |
| 17 | WORM 11:1 | 1 | W206961-000 |
| 17 | WORM 20:1 | 1 | W056965-000 |
| 17 | WORM 40:1 | 1 | W047022-000 |
| 18 | SCREW | 1 | W770013-000 |
| 19 | GASKET | 1 | NP460045-000 |
| 20 | SIDE COVER | 1 | NP250060-STL |
| 21 | BOLT | 4 | NP990414-188 |
| 22 | GEAR 11:1 | 1 | W206446-011 |
| 22 | GEAR 20:1 | 1 | W206446-020 |
| 22 | GEAR 40:1 | 1 | W206446-040 |
| 23 | THRUST WASHER | 1 | NP470029-000 |
| 24 | ECCENTRIC SHAFT | 1 | NP410054-000 |
| 25 | BEARING | 2 | NP400039-000 |
| 26 | STRK ADJ ASSEMBLY | 1 | NP260013-000 |
| 27 | KNOB | 1 | NP260001-GPC |
| 28 | KNOB COVER | 1 | NP250061-000 |
| 29 | SCREW | 1 | W771001-010 |
| 30 | LABEL | 1 | NP550084-000 |
| 31 | WASHER | 1 | W771006-STL |
| 32 | MOTOR ADAPT ASSY 56C | 1 | NP490030-000 |
| 32 | MOTOR ADAPT ASSY 71 | 1 | NP490029-000 |
| 33 | WORM SHAFT ASSY 56C | 1 | NP060031-A00 |
| 33 | WORM SHAFT ASSY IEC71 | 1 | NP060031-D00 |
| 34 | DC2/3 GEARBOX | 1 | NP010024-ALU |

| | | | |
|----|--------------------------|---|--------------|
| 35 | NAME TAG | 1 | NP550130-000 |
| 36 | NAME TAG SCREW | 4 | W771000-188 |
| 38 | SET SCREW | 2 | W771004-022 |
| 39 | NEEDLE BEARING | 1 | NP400046-000 |
| 40 | KEY-WORM GEAR | 1 | W773097-004 |
| 41 | ECCENTRIC SPACER | 1 | NP470031-000 |
| 42 | GASKET | 1 | NP460047-000 |
| 43 | SCREW | 2 | NP990008-STA |
| 44 | OIL SEAL | 1 | NP450029-000 |
| 45 | PIPE PLUG | 1 | W772565-STL |
| 46 | WASHER | 1 | W774034-STL |
| 47 | SPOOL ADAPTOR BOLT | 4 | W770534-STL |
| 48 | SPOOL ADAPTOR WASHER | 4 | NP991018-188 |
| 49 | RETAINING RING 71 FRAME | 1 | NP999041-000 |
| 50 | RETAINER 71 FRAME | 1 | NP470041-STL |
| 50 | RETAINER 56C FRAME | 1 | NP410075-000 |
| 51 | RETAINING RING 71 FRAME | 1 | NP999042-000 |
| 51 | RETAINING RING 56C FRAME | 1 | NP999032-000 |

14.3 Bill of Materials, DC3

| ITEM | DESCRIPTION | QTY | PART NUMBER |
|------|--------------------------------------|-----|-------------------------|
| 1 | SUPPORT PLATE | 1 | NP140055-BRS |
| 2 | DIAPHRAGM | 1 | NP170031-THY |
| 3 | REAGENT HEAD PVDF | 1 | NP160077-PVD |
| 3 | REAGENT HEAD PVC (obsolete) | 1 | NP160055-PVC |
| 3 | REAGENT HEAD 316 | 1 | NP160055-316 |
| 4 | BOLT | 4 | NP990436-188 |
| 5 | FLT WASHER | 4 | NP991018-188 |
| 6 | DC3 SPOOL ADAPTOR | 1 | NP140068-ALU |
| 7 | VALVE DISCHARGE PVDF ISO 7-1 | 1 | NP32BVC8-PVD |
| 7 | VALVE, DISCHARGE, 316, ISO 7-1 | 1 | NP32BAA8-316 |
| 7 | VALVE, DISCHARGE, PVC, ISO 7-1 (obs) | 1 | NP32BVC8-PVC |
| 7 | VALVE DISCHARGE PVDF NPT | 1 | NP32PVD8-PVD |
| 7 | VALVE, DISCHARGE, 316, NPT | 1 | NP32PAA8-316 |
| 7 | VALVE, DISCHARGE, PVC, NPT (obs) | 1 | NP32PVC8-PVC |
| 8 | VALVE, SUCTION, PVDF ISO 7-1 | 1 | NP31BVC8-PVD |
| 8 | VALVE, SUCTION, 316, ISO 7-1 | 1 | NP31BAA8-316 |
| 8 | VALVE, SUCTION, PVC, ISO 7-1 (obs) | 1 | NP31BVC8-PVC |
| 8 | VALVE , SUCTION, PVDF NPT | 1 | NP31PVD8-PVD |
| 8 | VALVE, SUCTION, 316, NPT | 1 | NP31PAA8-316 |
| 8 | VALVE, SUCTION, PVC, NPT (obs) | 1 | NP31PVC8-PVC |
| 9 | RETURN SPRING | 1 | NP430033-000 |
| 10 | BOTTOM COVER | 1 | NP250084-000 |
| 11 | BOTTOM COVER SCREW | 4 | NP992216-STL |
| 12 | STRADDLE ASSEMBLY | 1 | NP410066-000 |
| 13 | BEARING | 1 | NP400037-000 |
| 14 | ECCENTRIC | 1 | NP070022-000 |
| 15 | BEARING | 1 | NP400041-000 |
| 16 | THRUST WASHER | 2 | NP470033-000 |
| 17 | WORM 11:1 | 1 | W206961-000 |
| 17 | WORM 20:1 | 1 | W056965-000 |
| 17 | WORM 40:1 (obsolete) | 1 | W047022-000 |
| 18 | SCREW | 1 | W770013-000 |
| 19 | GASKET | 1 | NP460045-000 |
| 20 | SIDE COVER | 1 | NP250060-STL |
| 21 | BOLT | 4 | NP990414-188 |
| 22 | GEAR 11:1 | 1 | W206446-011 |
| 22 | GEAR 20:1 | 1 | W206446-020 |
| 22 | GEAR 40:1 (obsolete) | 1 | W206446-040 |
| 23 | THRUST WASHER | 1 | NP470029-000 |
| 24 | ECCENTRIC SHAFT | 1 | NP410054-000 |
| 25 | BEARING | 2 | NP400039-000 |
| 26 | STRK ADJ ASSEMBLY | 1 | NP260013-000 |
| 27 | KNOB | 1 | NP260001-GPC |
| 28 | KNOB COVER | 1 | NP250061-000 |
| 29 | SCREW | 1 | W771001-010 |
| 30 | LABEL | 1 | NP550084-000 |

| | | | |
|----|--------------------------|---|--------------|
| 31 | WASHER | 1 | W771006-STL |
| 32 | MOTOR ADAPT ASSY 56C | 1 | NP490030-000 |
| 32 | MOTOR ADAPT ASSY 71 | 1 | NP490029-000 |
| 33 | WORM SHAFT ASSY 56C | 1 | NP060031-A00 |
| 33 | WORM SHAFT ASSY IEC71 | 1 | NP060031-D00 |
| 34 | DC2/3 GEARBOX | 1 | NP010024-ALU |
| 35 | NAME TAG | 1 | NP550130-000 |
| 36 | NAME TAG SCREW | 4 | W771000-188 |
| 38 | SET SCREW | 2 | W771004-022 |
| 39 | NEEDLE BEARING | 1 | NP400046-000 |
| 40 | KEY-WORM GEAR | 1 | W773097-004 |
| 41 | ECCENTRIC SPACER | 1 | NP470031-000 |
| 42 | GASKET | 1 | NP460047-000 |
| 43 | SCREW | 2 | NP990008-STA |
| 44 | OIL SEAL | 1 | NP450029-000 |
| 45 | PIPE PLUG | 1 | W772565-STL |
| 46 | WASHER | 1 | W774034-STL |
| 47 | SPOOL ADAPTOR BOLT | 4 | W770534-STL |
| 48 | SPOOL ADAPTOR WASHER | 4 | NP991018-188 |
| 49 | RETAINING RING 71 FRAME | 1 | NP999041-000 |
| 50 | RETAINER 71 FRAME | 1 | NP470041-STL |
| 50 | RETAINER 56C FRAME | 1 | NP410075-000 |
| 51 | RETAINING RING 71 FRAME | 1 | NP999042-000 |
| 51 | RETAINING RING 56C FRAME | 1 | NP999032-000 |

This page intentionally left BLANK

14.4 Parts Diagram, DC4, 5, and 6

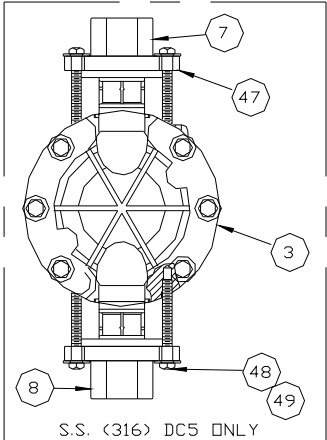
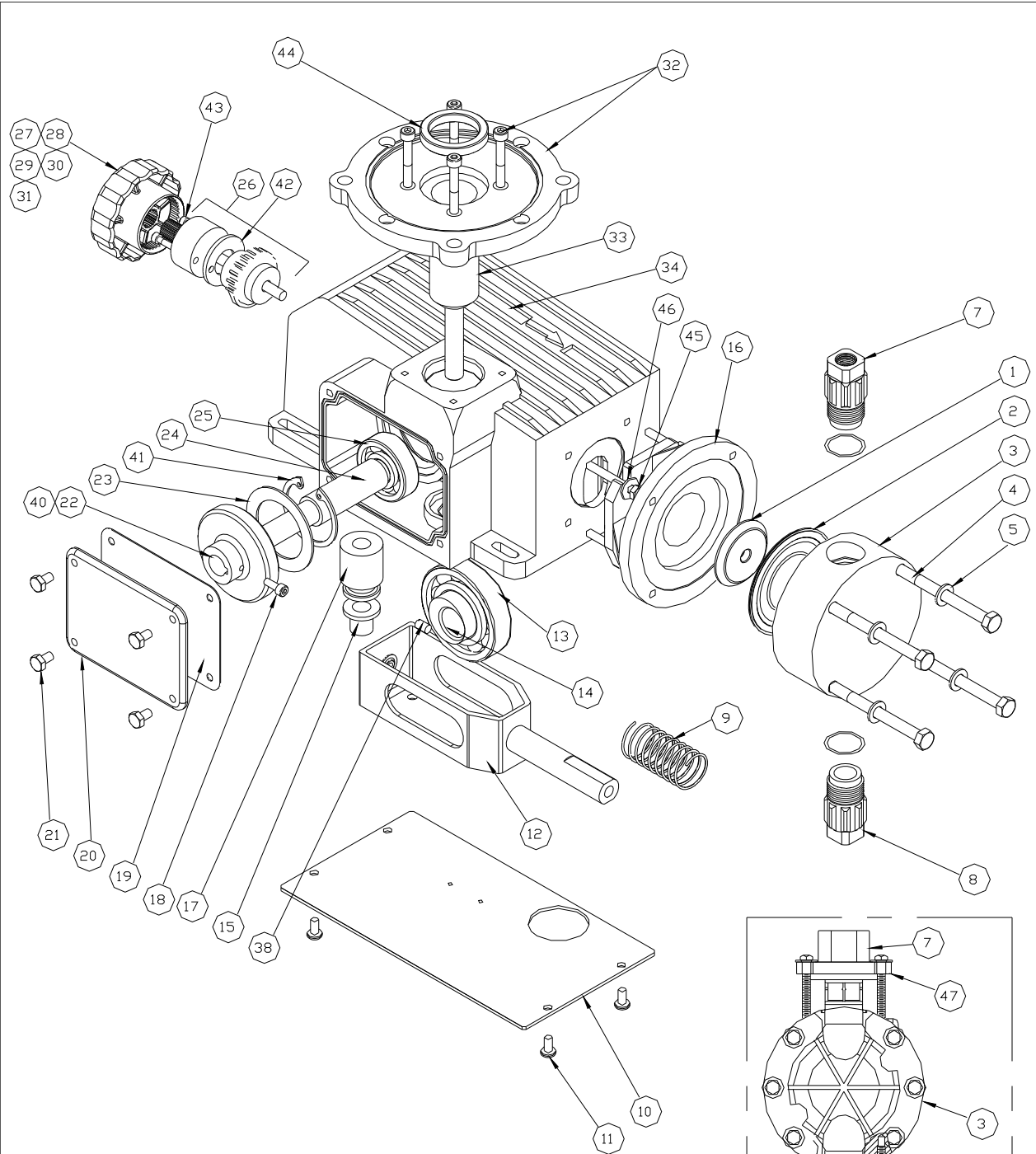

ALL DIMENSIONS ARE IN INCHES



DC4/5 MECHANICAL PUMP ISOMETRIC

| | | | | | | | |
|-----|-------------------------------|----------|--------------|----------|-------------|----------------|-------------|
| REF | ADDED DC5 316 HEAD/VALVE VIEW | 05/17/05 | SECTION/PAGE | OMNI/200 | DWN BY: JRY | DATE: 09/24/04 | AN00453-000 |
| | REVISION UPDATE | DATE | EFFECTIVE | 05/17/05 | | | |
| | | | SUPERSEDES | 02/11/05 | | | |

14.5 Bill of Materials, DC4

| ITEM | DESCRIPTION | QTY | PART NUMBER |
|------|--------------------------------------|-----|-------------------------|
| 1 | SUPPORT PLATE | 1 | NP140055-BRS |
| 2 | DIAPHRAGM | 1 | NP170031-THY |
| 3 | REAGENT HEAD PVDF | 1 | NP160077-PVD |
| 3 | REAGENT HEAD PVC (obsolete) | 1 | NP160055-PVC |
| 3 | REAGENT HEAD 316 | 1 | NP160055-316 |
| 4 | BOLT | 4 | NP990436-188 |
| 5 | FLT WASHER | 4 | NP991018-188 |
| 7 | VLV/CONN ISO 7-1 PVDF DISCHARGE | 1 | NP32BVC8-PVD |
| 7 | VLV/CONN ISO 7-1 316 DISCHARGE | 1 | NP32BAA8-316 |
| 7 | VLV/CONN ISO 7-1 PVC DISCHARGE (obs) | 1 | NP32BVC8-PVC |
| 7 | VLV/CONN NPT PVDF DISCHARGE | 1 | NP32PVD8-PVD |
| 7 | VLV/CONN NPT 316 DISCHARGE | 1 | NP32PAA8-316 |
| 7 | VLV/CONN NPT PVC DISCHARGE (obs) | 1 | NP32PVC8-PVC |
| 8 | VLV/CONN ISO 7-1 PVDF SUCTION | 1 | NP31BVC8-PVD |
| 8 | VLV/CONN ISO 7-1 316 SUCTION | 1 | NP31BAA8-316 |
| 8 | VLV/CONN ISO 7-1 PVC SUCTION (obs) | 1 | NP31BVC8-PVC |
| 8 | VLV/CONN NPT PVDF SUCTION | 1 | NP31PVD8-PVD |
| 8 | VLV/CONN NPT 316 SUCT | 1 | NP31PAA8-316 |
| 8 | VLV/CONN NPT PVC SUCT (obs) | 1 | NP31PVC8-PVC |
| 9 | RETURN SPRING | 1 | NP430034-000 |
| 10 | BOTTOM COVER | 1 | NP250085-000 |
| 11 | BOTTOM COVER SCREW | 4 | NP992216-STL |
| 12 | STRADLE ASSEMBLY | 1 | NP410067-000 |
| 13 | BEARING | 1 | NP400038-000 |
| 14 | ECCENTRIC | 1 | NP070023-000 |
| 15 | BEARING | 1 | NP400042-000 |
| 16 | DC4 SPOOL ADAPTOR | 1 | NP140068-ALU |
| 17 | WORM 8:1 | 1 | W208764-008 |
| 17 | WORM 10:1 | 1 | W208764-010 |
| 17 | WORM 15:1 | 1 | W208764-015 |
| 17 | WORM 30:1 (obsolete) | 1 | W208764-030 |
| 18 | SCREW | 1 | W770010-000 |
| 19 | GASKET | 1 | NP460045-000 |
| 20 | SIDE COVER | 1 | NP250060-STL |
| 21 | BOLT | 4 | NP990414-188 |
| 22 | GEAR 8:1 | 1 | W208765-008 |
| 22 | GEAR 10:1 | 1 | W208765-010 |
| 22 | GEAR 15:1 | 1 | W208765-015 |
| 22 | GEAR 30:1 (obsolete) | 1 | W208765-030 |
| 23 | THRUST WASHER | 1 | NP470030-000 |
| 24 | ECCENTRIC SHAFT | 1 | NP410055-000 |
| 25 | BEARING | 2 | NP400040-000 |
| 26 | STRK ADJ ASSEMBLY | 1 | NP260013-000 |
| 27 | KNOB | 1 | NP260001-GPC |
| 28 | KNOB COVER | 1 | NP250061-000 |
| 29 | SCREW | 1 | W771001-010 |

| | | | |
|----|-----------------------|---|--------------|
| 30 | LABEL | 1 | NP550084-000 |
| 31 | WASHER | 1 | W771006-STL |
| 32 | MOTOR ADAPT ASSY 56C | 1 | NP490030-000 |
| 32 | MOTOR ADAPT ASSY 71 | 1 | NP490029-000 |
| 33 | WORM SHAFT ASSY 56C | 1 | NP060032-A00 |
| 33 | WORM SHAFT ASSY IEC71 | 1 | NP060032-B00 |
| 34 | DC4/5 GEARBOX | 1 | NP010023-ALU |
| 35 | NAME TAG | 1 | NP550130-000 |
| 36 | NAME TAG SCREW | 4 | W771000-188 |
| 38 | SET SCREW | 2 | W771004-032 |
| 40 | KEY-WORM GEAR | 1 | W773098-004 |
| 41 | RETAINING RING | 1 | NP999032-STL |
| 42 | GASKET | 1 | NP460047-000 |
| 43 | SCREW | 2 | NP990008-STA |
| 44 | OIL SEAL | 1 | NP450029-000 |
| 45 | SPOOL ADAPTOR BOLT | 4 | W770534-STL |
| 46 | SPOOL ADAPTOR WASHER | 4 | NP991018-188 |

14.6 Bill of Materials, DC5

| ITEM | DESCRIPTION | QTY | PART NUMBER |
|------|--------------------------------------|-----|-----------------|
| 1 | SUPPORT PLATE | 1 | NP140071-BRS |
| 2 | DIAPHRAGM | 1 | NP170037-THY |
| 3 | REAGENT HEAD PVDF | 1 | NP160022-PVD |
| 3 | REAGENT HEAD PP | 1 | NP160022-PPL |
| 3 | REAGENT HEAD PVC | 1 | NP160017-PVC |
| 3 | REAGENT HEAD 316 | 1 | NP160004-316 |
| 4 | BOLT | 6 | NP990436-188 |
| 5 | FLT WASHER | 6 | NP991018-188 |
| 7 | VLV ASSY DISCHARGE PVDF NPT | 1 | NP87NLFUCJ-DISC |
| 7 | VLV ASSY DISCHARGE PVDF ISO 7-1 | 1 | NP87NLFUCJ-BDIS |
| 7 | VLV ASSY DISCHARGE 316 NPT | 1 | NP87AAAUCJ-DISC |
| 7 | VLV ASSY DISCHARGE 316 ISO 7-1 | 1 | NP87AAAUCJ-BDIS |
| 7 | VLV ASSY DISCHARGE PVC NPT (obs) | 1 | NP87SLVUCJ-DISC |
| 7 | VLV ASSY DISCHARGE PVC ISO 7-1 (obs) | 1 | NP87SLVUCJ-BDIS |
| 8 | VLV ASSY SUCTION PVDF NPT | 1 | NP87NLFUCJ-SUCT |
| 8 | VLV ASSY SUCTION PVDF ISO 7-1 | 1 | NP87NLFUCJ-BSUC |
| 8 | VLV ASSY SUCTION 316 NPT | 1 | NP87AAAUCJ-SUCT |
| 8 | VLV ASSY SUCTION 316 ISO 7-1 | 1 | NP87AAAUCJ-BSUC |
| 8 | VLV ASSY SUCTION PVC NPT (obs) | 1 | NP87SLVUCJ-SUCT |
| 8 | VLV ASSY SUCTION PVC ISO 7-1 (obs) | 1 | NP87SLVUCJ-BSUC |
| 9 | RETURN SPRING | 1 | NP430034-000 |
| 10 | BOTTOM COVER | 1 | NP250085-000 |
| 11 | BOTTOM COVER BOLT | 4 | NP992216-STL |
| 12 | STRADLE ASSEMBLY | 1 | NP410067-000 |
| 13 | BEARING | 1 | NP400038-000 |
| 14 | ECCENTRIC | 1 | NP070023-000 |
| 15 | BEARING | 1 | NP400042-000 |
| 16 | DC5 SPOOL ADAPTOR | 1 | NP140069-ALU |
| 17 | WORM 8:1 | 1 | W208764-008 |
| 17 | WORM 10:1 | 1 | W208764-010 |
| 17 | WORM 15:1 (obsolete) | 1 | W208764-015 |
| 17 | WORM 30:1 (obsolete) | 1 | W208764-030 |
| 18 | SCREW | 1 | W770010-000 |
| 19 | GASKET | 1 | NP460045-000 |
| 20 | SIDE COVER | 1 | NP250060-STL |
| 21 | BOLT | 4 | NP990414-188 |
| 22 | GEAR 8:1 | 1 | W208765-008 |
| 22 | GEAR 10:1 | 1 | W208765-010 |
| 22 | GEAR 15:1 (obsolete) | 1 | W208765-015 |
| 22 | GEAR 30:1 (obsolete) | 1 | W208765-030 |
| 23 | THRUST WASHER | 1 | NP470030-000 |
| 24 | ECCENTRIC SHAFT | 1 | NP410055-000 |
| 25 | BEARING | 2 | NP400040-000 |
| 26 | STRK ADJ ASSEMBLY | 1 | NP260013-000 |
| 27 | KNOB | 1 | NP260001-GPC |
| 28 | KNOB COVER | 1 | NP250061-000 |

| | | | |
|----|-----------------------|---|--------------|
| 29 | SCREW | 1 | W771001-010 |
| 30 | LABEL | 1 | NP550084-000 |
| 31 | WASHER | 1 | W771006-STL |
| 32 | MOTOR ADAPT ASSY 56C | 1 | NP490030-000 |
| 32 | MOTOR ADAPT ASSY 71 | 1 | NP490029-000 |
| 33 | WORM SHAFT ASSY 56C | 1 | NP060032-A00 |
| 33 | WORM SHAFT ASSY IEC71 | 1 | NP060032-B00 |
| 34 | DC4/5 GEARBOX | 1 | NP010023-ALU |
| 35 | NAME TAG | 1 | NP550130-000 |
| 36 | NAME TAG SCREW | 4 | W771000-188 |
| 38 | SET SCREW | 2 | W771004-032 |
| 40 | KEY-WORM GEAR | 1 | W773098-004 |
| 41 | RETAINING RING | 1 | NP999032-STL |
| 42 | GASKET | 1 | NP460047-000 |
| 43 | SCREW | 2 | NP990008-STA |
| 44 | OIL SEAL | 1 | NP450029-000 |
| 45 | SPOOL ADAPTOR BOLT | 4 | W770534-STL |
| 46 | SPOOL ADAPTOR WASHER | 4 | NP991018-188 |
| 47 | TIEBAR | 2 | NP360004-000 |
| 48 | TIEBAR BOLT | 8 | NP990435-188 |
| 49 | TIEBAR WASHER | 8 | NP991018-188 |

14.7 Bill of Materials, DC6

| ITEM | DESCRIPTION | QTY | PART NUMBER |
|------|---------------------------------|-----|-----------------|
| 1 | SUPPORT PLATE | 1 | NP140081-STL |
| 2 | DIAPHRAGM | 1 | NP170039-THY |
| 3 | REAGENT HEAD FPP | 1 | NP160023-FPP |
| 3 | REAGENT HEAD PVDF | 1 | NP160023-PVD |
| 3 | REAGENT HEAD 316 | 1 | NP160031-316 |
| 4 | BOLT | 6 | NP990477-188 |
| 5 | FLT WASHER | 6 | NP991018-188 |
| 7 | VLV ASSY DISCHARGE PVDF NPT | 1 | NP87NLFUCJ-DISC |
| 7 | VLV ASSY DISCHARGE PVDF ISO 7-1 | 1 | NP87NLFUCJ-BDIS |
| 7 | VLV ASSY DISCHARGE 316 NPT | 1 | NP87AAAUCJ-DISC |
| 7 | VLV ASSY DISCHARGE 316 ISO 7-1 | 1 | NP87AAAUCJ-BDIS |
| 8 | VLV ASSY SUCTION PVDF NPT | 1 | NP87NLFUCJ-SUCT |
| 8 | VLV ASSY SUCTION PVDF ISO 7-1 | 1 | NP87NLFUCJ-BSUC |
| 8 | VLV ASSY SUCTION 316 NPT | 1 | NP87AAAUCJ-SUCT |
| 8 | VLV ASSY SUCTION 316 ISO 7-1 | 1 | NP87AAAUCJ-BSUC |
| 9 | RETURN SPRING | 1 | NP430034-000 |
| 10 | BOTTOM COVER | 1 | NP250085-000 |
| 11 | BOTTOM COVER BOLT | 4 | NP992216-STL |
| 12 | STRADLE ASSEMBLY | 1 | NP410067-000 |
| 13 | BEARING | 1 | NP400038-000 |
| 14 | ECCENTRIC | 1 | NP070023-000 |
| 15 | BEARING | 1 | NP400042-000 |
| 16 | DC5 SPOOL ADAPTOR | 1 | NP140080-ALU |
| 17 | WORM 8:1 | 1 | W208764-008 |
| 17 | WORM 10:1 | 1 | W208764-010 |
| 18 | SCREW | 1 | W770010-000 |
| 19 | GASKET | 1 | NP460045-000 |
| 20 | SIDE COVER | 1 | NP250060-STL |
| 21 | BOLT | 4 | NP990414-188 |
| 22 | GEAR 8:1 | 1 | W208765-008 |
| 22 | GEAR 10:1 | 1 | W208765-010 |
| 23 | THRUST WASHER | 1 | NP470030-000 |
| 24 | ECCENTRIC SHAFT | 1 | NP410055-000 |
| 25 | BEARING | 2 | NP400040-000 |
| 26 | STRK ADJ ASSEMBLY | 1 | NP260013-000 |
| 27 | KNOB | 1 | NP260001-GPC |
| 28 | KNOB COVER | 1 | NP250061-000 |
| 29 | SCREW | 1 | W771001-010 |
| 30 | LABEL | 1 | NP550084-000 |
| 31 | WASHER | 1 | W771006-STL |
| 32 | MOTOR ADAPT ASSY 56C | 1 | NP490030-000 |
| 32 | MOTOR ADAPT ASSY 71 | 1 | NP490029-000 |
| 33 | WORM SHAFT ASSY 56C | 1 | NP060032-A00 |
| 33 | WORM SHAFT ASSY IEC71 | 1 | NP060032-B00 |

| | | | |
|----|----------------------|---|--------------|
| 34 | DC4/5/6 GEARBOX | 1 | NP010023-ALU |
| 35 | NAME TAG | 1 | NP550130-000 |
| 36 | NAME TAG SCREW | 4 | W771000-188 |
| 38 | SET SCREW | 2 | W771004-032 |
| 40 | KEY-WORM GEAR | 1 | W773098-004 |
| 41 | RETAINING RING | 1 | NP999032-STL |
| 42 | GASKET | 1 | NP460047-000 |
| 43 | SCREW | 2 | NP990008-STA |
| 44 | OIL SEAL | 1 | NP450029-000 |
| 45 | SPOOL ADAPTOR BOLT | 4 | W770534-STL |
| 46 | SPOOL ADAPTOR WASHER | 4 | NP991018-188 |
| 47 | TIEBAR | 2 | NP360004-000 |
| 48 | TIEBAR BOLT | 8 | NP990435-188 |
| 49 | TIEBAR WASHER | 8 | NP991018-188 |



STANDARD PUMP OPERATIONS
27101 Airport Road
Punta Gorda, FL 33982
(941) 575-3800 Fax (941) 575-4085
www.pulsatron.com

Bulletin #: IOM-OM-1104- E
Rev E