



Electrolux

air-o-convect air-o-convect Manual Boilerless Combi Oven 61 (gas)

ITEM # _____

MODEL # _____

NAME # _____

SIS # _____

AIA # _____



Electrolux



air-o-convect

air-o-convect Manual Boilerless Combi Oven 61 (gas)

269750 (AOS061GCP1)

air-o-convect Boilerless Combi Oven 61
120V/1ph/60Hz

Short Form Specification

Item No.

Unit to be Electrolux air-o-convect Boilerless Combi Oven (gas).

air-o-convect performs all of the functions of a convection oven and has a boilerless steaming capabilities to add and retain moisture for high quality, consistent cooking cycles. Cooking modes include a convection (hot air) cycle 77 °F-572 °F (25°C-300°C) with an automatic moisture control function with 11 settings from zero to high moisture, double step cooking process, automatic pre-heating, a hold function and automatic rapid cooling. All 304 stainless steel construction, seamless hygienic cooking chamber with all rounded corners. Double thermo-glazed door with open frame construction for cool outside door panel. IPX5 (NEMA 4) spray water protection certification.

air-o-clean™ automatic and built-in self cleaning system.

Covered by Electrolux Platinum Star® Service Program, two-year parts and one-year labor warranty, installation start-up and performance checkup after one year from installation.

Main Features

- Dry hot convection cycle 77 °F-572 °F (25°C to 300°C) ideal for low humidity baking.
- Automatic moisture settings (11 settings) for boilerless steam generation.
 - 0 = no additional moisture (air frying, dehydrating, baking, browning)
 - 1-2 = low moisture (roasting, grilling, searing, baking, cookies, cakes, grill cheese)
 - 3-4 = medium low moisture (au gratin vegetables, roasted meat and fish)
 - 5-6 = medium moisture (roasting small portions poultry, meet and fish, casserole, pizza)
 - 7-8 = medium-high moisture (Roasting and backing, large portions of meat, whole: chicken, turkey, ham)
 - 9-10 = high moisture (proofing, low temperature steaming, steam vegetables, rice, pasta, fish, shell fish, bagged product, sous vide, re-thermalization, baking)
- Double step cooking (first phase with moisture, second phase dry for browning).
- Core temperature probe.
- Variable fan speed (radial fan): full speed or pulse ventilation (Hold) for baking and slow cooking.
- Hold function for keeping food warm at the end of a cycle.
- Exhaust valve electronically controlled to extract excess humidity.
- Automatic and manual rapid cooling activation when going from a higher to a lower temperature.
- air-o-clean™ automatic and built-in self cleaning system (4 automatic and 1 semi-automatic cycles).
- Electrolux Platinum Star® Service package included:
 - 2-year parts, 1-year labor warranty.
 - Start-up installation check.
 - Equipment check-up after 12 months from installation.
- IPX5 (NEMA 4) – Water Jets protected (Water projected by a nozzle (6.3 mm) against enclosure from any direction shall have no harmful effects.).
- ETL safety approved, complies with UL 197 and GSA 22.2 listings.
- ETL sanitation approved, complies with NSF/ANSI 2 listing.

Construction

- All 304 stainless steel construction.
- Seamless hygienic cooking chamber with all rounded corners for easy cleaning.
- Double thermo-glazed door with open frame construction, for cool outside door panel. Swing hinged easy-release inner glass on door for easy cleaning.
- Swing hinged front panel for easy service access to main components.

*Electrolux recommends a certified service agent perform equipment install and start-up, and an Electrolux certified chef be hired to train kitchen staff on equipment operation and maintenance.



APPROVAL: _____

Electrolux Professional, Inc.

www.electroluxusa.com/professional

10200 David Taylor Drive, Charlotte, NC 28262 • Telephone Number: 866-449-4200 • Fax Number: 704-547-7401

air-o-convect
Manual Boilerless Combi Oven 61 (gas)



Electrolux

air-o-convect air-o-convect Manual Boilerless Combi Oven 61 (gas)

Included Accessories

- 3 of Single 304 stainless steel grid (12"x20") PNC 922062

Optional Accessories

- Wheel kit for base for 61, 62, 101 and 102 oven bases PNC 922003
- Trolley for rack cassette for 61 and 101 oven PNC 922004
- 6 rack cassette for 61 oven (standard pitch) PNC 922005
- 5 rack cassette for 61 oven (increased pitch) PNC 922008
- Pair of half size oven racks, type 304 stainless steel PNC 922017
- Tray support, for 61 and 101 oven bases PNC 922021
- Chicken Racks, pair (2) (fits 8 chickens per rack) PNC 922036
- GN 1/1 (12" x 20") tray made of aluminium alloy with no-stick coating, 3/4" (20 mm) deep PNC 922090
- GN 1/1 (12" x 20") tray made of aluminium alloy with no-stick coating, 1 1/2" (40 mm) deep PNC 922091
- GN 1/1 (12" x 20") tray made of aluminium alloy with no-stick coating, 2 1/2" (65 mm) deep PNC 922092
- Fat filter for 61 and 62 oven PNC 922177
- Open base with rack guides for 61 and 101 oven PNC 922195
- GN 1/1 (12" x 20") frying griddle, made of aluminium alloy with no-stick coating PNC 922215
- Pair of Frying Baskets PNC 922239
- Heat shield for 61 on top of 61 oven stacking kit PNC 922244
- Heat shield for 61 on top of 101 oven stacking kit PNC 922245
- Control Panel filter for 61 and 101 oven PNC 922246
- Heat shield for 61 oven PNC 922250
- Kit Bakery Rack for 61 oven PNC 922282
- Oven grill made of aluminium alloy with no-stick coating PNC 922289
- GN 1/1 (12" x 20") egg fryer grid, made of aluminium alloy with no-stick coating. Fits 8 eggs PNC 922290
- GN 1/1 (12" x 20") baking sheet, made of aluminium alloy with no-stick coating. PNC 922299



Electrolux

air-o-convect air-o-convect Manual Boilerless Combi Oven 61 (gas)

Front

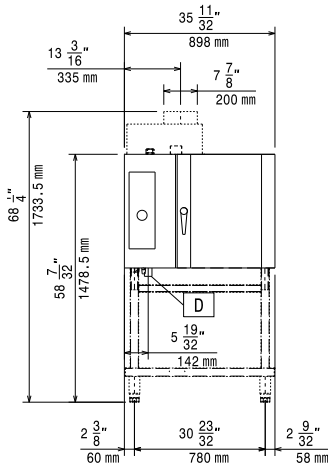

Top

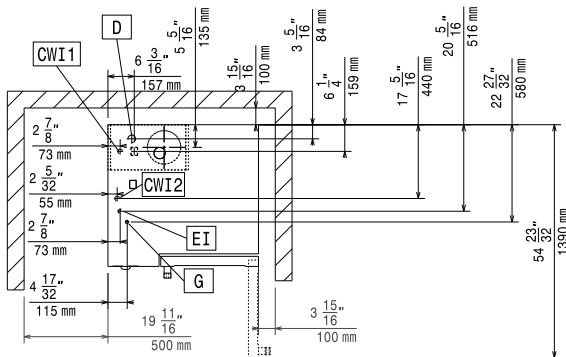

- CWI = Cold Water inlet
- D = Drain
- EI = Electrical connection
- G = Gas connection

Side

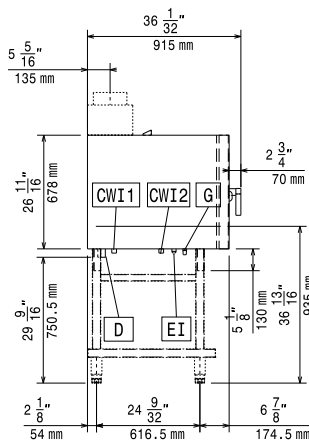

Electric

Supply voltage:	269750(AOS061GCP1)	120 V/1N ph/60 Hz
Amps:		3.8
Connected load:		0.45 kW
Circuit breaker required		

Gas

Gas Power:	40908 Btu/hr (12 kW)
Max rated thermal load:	
Natural gas:	
Steam generator:	12 kW
Heating elements:	40908 BTU (12 kW)
Total thermal load:	40908 BTU (12 kW)
LPG:	
Steam generator:	40908 BTU (12 kW)
Heating elements:	40908 BTU (12 kW)
Total thermal load:	40908 BTU (12 kW)

Water:

Water inlet "CW" connection:	3/4"
Total hardness:	5-50 ppm
Water consumption (gal./hr.):	Min: 0.09 Max: 2.77
Pressure:	1.5-4.5 bar
Drain "D":	1"1/4

Electrolux recommends the use of treated water, based on testing of specific water conditions.

Please refer to user manual for detailed water quality information

Installation:

Clearance:	2" (5 cm) rear and right hand sides
Suggested clearance for service access:	20" (50 cm) left hand side

Capacity:

Sheet pans:	6 - 12" x 20"
GN:	6 - 1/1 containers
Max load capacity:	106 lbs. (480 kg)

Key Information:

Net weight:	331 lbs (150 kg)
Shipping width:	37 5/8" (955 mm)
Shipping depth:	38 3/4" (985 mm)
Shipping height:	41 15/16" (1065 mm)
Shipping weight:	373 lbs (169 kg)
Shipping volume:	35.37 ft³ (1 m³)

air-o-convect
air-o-convect Manual Boilerless Combi Oven 61 (gas)

The company reserves the right to make modifications to the products without prior notice. All information correct at time of printing.