



SMC-050 to SMC-150 Series

0.5 to 1.5 hp Portable Chillers

Operation and Installation Manual

Sterling, Inc./Sterlco
P. O. Box 245018
5200 West Clinton Avenue
Milwaukee, WI 53224-9518
Tel (414) 354-0970
Fax (414) 354-6421

Sterling/Sterlco is committed to a continuing program of product improvement.
Specifications, appearance, and dimensions described in this manual
are subject to change without notice.

© Copyright Sterling/Sterlco and Sterling, Inc. 2003 All rights reserved. Part No. A0544325	Effective 7/30/2003 Bulletin No. SC2-615.1
---	---

Safety Considerations

SMC Series Chillers are designed to provide safe and reliable operation when installed and operated within design specifications, following national and local safety codes.

To avoid possible personnel injury or equipment damage when installing, operating or maintaining this equipment, use good judgment and follow these safe practices:

- ☑ Follow all **SAFETY CODES**.
- ☑ Wear **SAFETY GLASSES** and **WORK GLOVES**.
- ☑ Use care when **LOADING, UNLOADING, RIGGING, or MOVING** this equipment.
- ☑ Operate this equipment within design specifications.
- ☑ **OPEN, TAG, and LOCK ALL DISCONNECTS** before working on equipment. It is a good idea to remove the fuses and carry them with you.
- ☑ Make sure the chiller is properly **GROUNDING** before switching power on.
- ☑ When welding or brazing in or around this equipment, be sure **VENTILATION** is **ADEQUATE. PROTECT** adjacent materials from flame or sparks by shielding with sheet metal. An approved **FIRE EXTINGUISHER** should be close at hand and ready for use if needed.
- ☑ The refrigeration system can develop refrigerant pressures in excess of **500 psi (3,450 kPa)**. **DO NOT CUT** into the system without first relieving pressure.
- ☑ Do not jump or bypass any electrical safety control.
- ☑ Do not restore power until all tools, test equipment etc. have been removed and the panels replaced.
- ☑ Only **PROPERLY TRAINED** personnel familiar with the information within this manual should work on this equipment.

Table of Contents

1 General Information 7

- 1-1 Introduction
- 1-2 Necessary Documents
- 1-3 Models Covered
- 1-4 Available Options
- 1-5 Uncrating Your New Chiller
- 1-6 In the Event of Shipping Damages
- 1-7 If the Shipment is Not Complete
- 1-8 If the Shipment is Incorrect
- 1-9 Returns

2 Chiller Installation 13

- 2-1 Electrical Connections
- 2-2 Process Water Connections
- 2-3 SMC Condenser Air Supply
- 2-4 Water Reservoir
- 2-5 Overhead Process Considerations

3 Sequence of Operation 17

- 3-1 Chilled Water Circuit
- 3-2 Refrigeration Circuit
- 3-3 High Pressure Cutout
- 3-4 Low Pressure Cutout
- 3-5 Remote Start/Stop Interlock

Table of Contents

4	Startup Checklists.....	23
4-1	Introduction	
4-2	SMC Pre-Startup Checklist	
4-3	SMC Startup Checklist	
5	Microprocessor Control	25
5-1	Introduction	
5-2	Setting the Process Water Temperature	
5-3	Setting the Alarm Value	
6	Optional Graphic Panel	27
6-1	Indicator Lights	
6-2	Switches	
7	Routine Maintenance	29
7-1	Lubrication	
7-2	Condenser Maintenance	
8	Troubleshooting Guide.....	33

Charts and Figures

1	<i>SMC050A Process Pump Curves</i>	10
2	<i>SMC100A Process Pump Curves</i>	10
3	<i>SMC150A Process Pump Curves</i>	11
4	<i>SMC Series Chiller Specifications</i>	12
5	<i>Ethylene Glycol Curve</i>	15
6	<i>Overhead Piping</i>	16
7	<i>SMC Component Identification</i>	19
8	<i>Piping Schematic — 1 Pump with Reservoir</i>	20
9	<i>Piping Schematic — 1 Pump without Reservoir</i>	21
10	<i>Piping Schematic — No Pump, No Reservoir</i>	22
11	<i>SMC Water Circuit Pressure Drop Table</i>	24
12	<i>SMC Control</i>	26
13	<i>Optional Graphic Panel</i>	28
14	<i>Typical SMC Subpanel</i>	29
15	<i>Typical SMC Wiring Schematic</i>	30
16	<i>SMC Wiring Schematic for Chillers with No Pump or Reservoir</i>	31
17	<i>SMC Spare Parts List</i>	35

1-1 Introduction

SMC Series Water Chillers are reliable, accurate, and easy-to-use air cooled chillers designed for use with water/glycol. Standard range of operation is 30°F (-1°C) to 65°F (18°C). A crankcase pressure regulating valve option is available for processes requiring a leaving water temperature of up to 75°F (24°C). SMC models are available in ½ hp (373 W), 1 hp (746 W), and 1½ hp (1,118 W) models and have an internal six gallon (23 liter) reservoir. All models are self contained, fully assembled, and shipped ready to use.

A properly installed, operated, and maintained SMC Series Chiller will provide many years of reliable operation. To get the most satisfaction from your new chiller, read and follow the instructions in this manual.

1-2 Necessary Documents

The following documents are necessary for the operation, installation and maintenance SMC Series Chillers. Additional copies are available from Sterlco. Familiarize the appropriate personnel with these documents:

- This manual.
- The electrical schematic and connection diagram mounted inside the control enclosure. Typical schematics for general reference are provided in Figures 14 and 15 on Pages 32 and 33.
- The operation and installation manuals for installed accessories and options.
- The Customer Parts List included in the information packet.

1-3 Models Covered

This manual provides operation, installation, and maintenance instructions for SMC Series Chillers. Model numbers are on the serial tag. Please know the model number, serial number and operating voltage of your chiller if you need to contact Sterlco.

SMC Series Chiller models are designated by approximate compressor horsepower. A **SMC050** chiller has a ½ hp (373 W) compressor, a **SMC100** chiller has a 1 hp (746 W) compressor, and a **SMC150** chiller has a 1½ hp (1,118 W) compressor.

1-4 Available Options

SMC Series Chillers are available with options that tailor the unit to your requirements. Some are factory installed, some can be retrofitted in the field. Consult your local Sterlco Sales Representative. Some of these options are:

Special Pumps

Special pump options are available for greater pressure and flow rates. Bronze and stainless steel wetted surface standard flow pumps ranging from 30 psi (207 kPa) to 60 psi (414 kPa) are available.

Reservoirs

SMC Series Chillers are available without a reservoir for processes that use their own reservoir.

Power Cord

A 10 foot (3 meter) power cord is available to speed SMC installation.

Casters

Four 2-inch (5 cm) swivel casters add mobility to the SMC unit.

CPR Valve

A crankcase pressure regulating (CPR) valve is available for leaving water temperatures up to 75°F (24°C).

1-5 Uncrating Your New Chiller

SMC Series Chillers are shipped mounted on a skid, enclosed in a plastic wrapper, and open crated on all four sides and top.

- Pry the crating away from the skid and remove. Use a pry bar to remove the blocks securing the unit to the skid.
- Lift the unit off the skid with a fork truck. Insert forks between skid and chiller from the side until they protrude beyond the opposite side of the unit. The forks must be equidistant from the center line of the unit and the unit must be balanced on the forks.
- Lift slowly and only high enough to clear the skid. Use a pry bar if necessary to remove the skid from the unit.
- Lower slowly. The unit will land on its feet or casters and can be moved into position.

1-6 In the Event of Shipping Damages

Important!

According to the contract terms and conditions of the Carrier, the responsibility of the Shipper ends at the time and place of shipment. The Carrier then assumes full responsibility of the shipment.

- Notify the transportation company's local agent.
- Hold the damaged goods and packing material for the examining agent's inspection. Do not return any goods to Sterlco before the transportation company inspection and authorization.
- File a claim against the transportation company. Substantiate the claim by referring to the agent's report. A certified copy of our invoice is available upon request. The original Bill of Lading is attached to our original invoice. If the shipment was prepaid, write us for a receipted transportation bill.
- Advise Sterlco regarding your wish for replacement.

1-7 If the Shipment is Not Complete

Check the packing list. The apparent shortage may be intentional. Back-ordered items are noted on the packing list. You should have:

- SMC Series Chiller
- Bill of Lading
- Packing List
- Operating and Installation Packet

Re-inspect the container and packing material to see if smaller items have been missed during unpacking. Determine that the item was not taken from the area before the shipment was checked in. Notify Sterlco immediately of the shortage.

1-8 If the Shipment is Incorrect

- If the shipment is not what you ordered, contact Sterlco immediately. Include the order number and item.
- Hold the items until shipping instructions are received.

1-9 Returns

Important!
Do not return any damaged or incorrect items until you receive shipping instructions from STERLCO.

Figure 1
 SMC050A Process Pump Curves

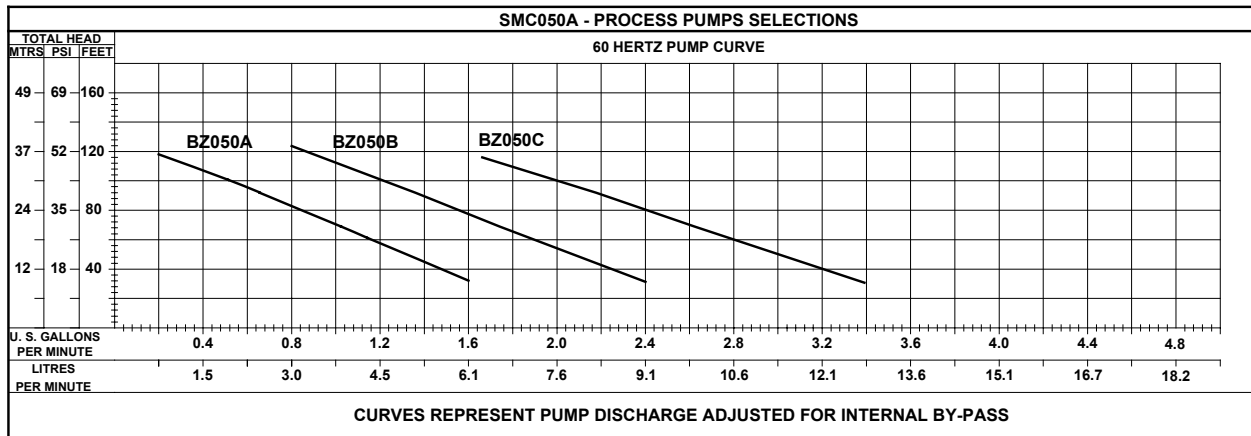

Do not extrapolate pump curves.

Figure 2
 SMC100A Process Pump Curves

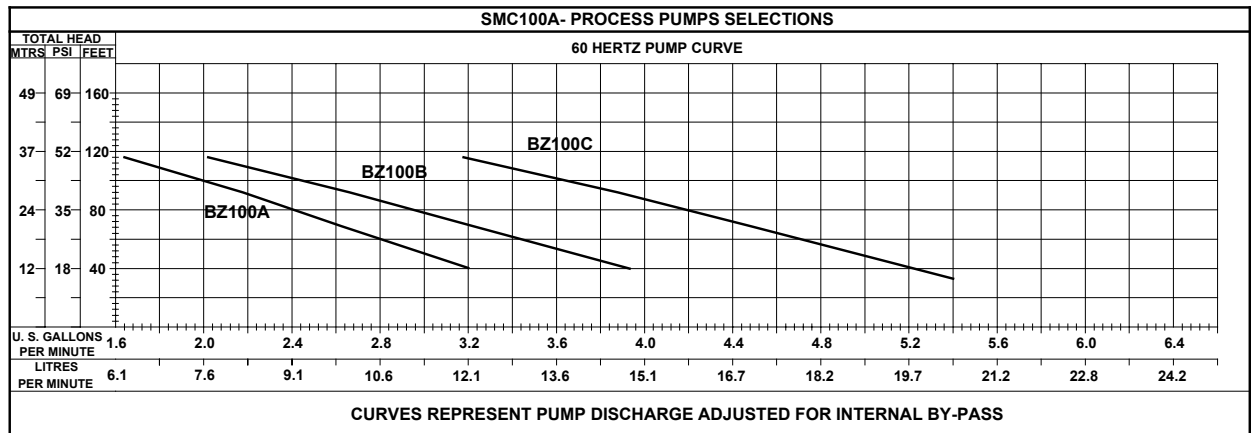

Do not extrapolate pump curves.

Figure 3
SMC150A Process Pump Curves

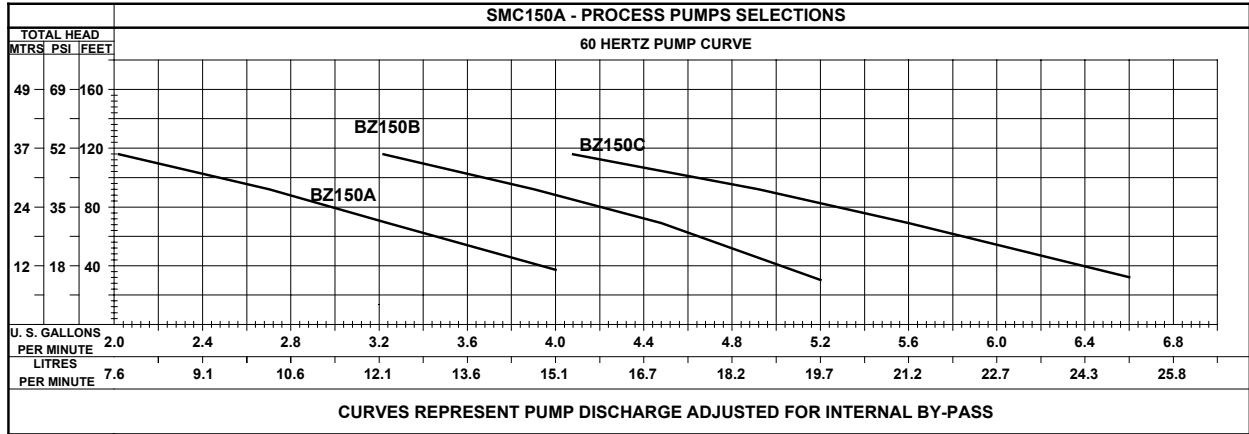

Do not extrapolate pump curves.

Figure 4
SMC Series Chiller Specifications

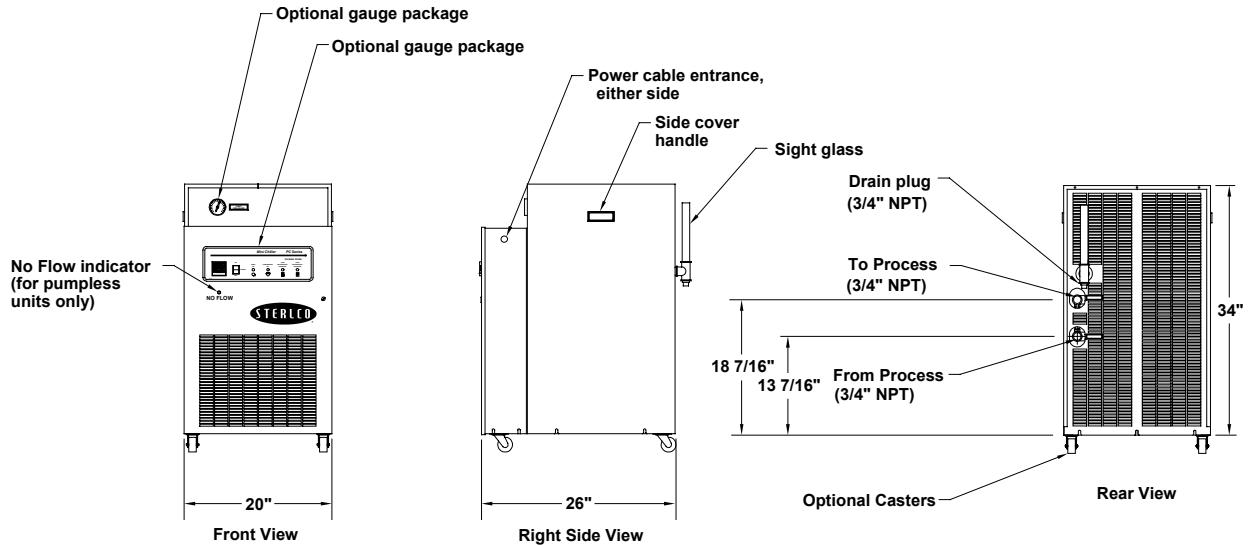

Model Number	Capacity @ 65°F LWT 75°F Ambient (Btuh)	Capacity @ 50°F LWT 90°F Ambient (Btuh)	Nominal Chilled Water (gpm)	Compressor (hp)	Pump	Process Connection (inches NPT)	Amp Draw 230/1/60 Running	Dimensions (inches)			Operating Weight (lbs)	Shipping Weight (lbs)
								L	W	H		
SMC-050	8,100	4,800	1.2	1/2	1/3 hp, 1.2 gpm @ 24 psig	3/4	8A	20	26	34	265	265
SMC-100	14,000	9,550	2.4	1	1/3 hp, 2.4 gpm @ 34 psig	3/4	10A	20	26	34	325	325
SMC-150	25,400	16,000	3.6	1 1/2	1/3 hp, 3.6 gpm @ 24 psig	3/4	12A	20	26	34	345	345

Model Number	Capacity @ 18°C LWT, 24°C Ambient (watts)	Capacity @ 10°C LWT, 32°C Ambient (watts)	Nominal Chilled Water (lpm)	Compressor (watts)	Pump	Process Connection (inches NPT)	Amp Draw 230/1/60 Running	Dimensions (cm)			Operating Weight (kg)	Shipping Weight (kg)
								L	W	H		
SMC-050	2,374	1,407	4.5	373	224 watts, 4.5 lpm @ 207 kPa	3/4	8A	51	66	86	120	120
SMC-100	4,103	2,800	9.0	746	224 watts, 9.0 lpm @ 234 kPa	3/4	10A	51	66	86	147	147
SMC-150	7,444	4,690	13.6	1,118	224 watts, 13.6 lpm @ 207 kPa	3/4	12A	51	66	86	156	156

2-1 Electrical Connections

Check serial tag voltage and amperage requirements and make sure your electrical service conforms. See Figure 4 on Page 12 for total running amps.

Bring properly sized power leads and ground from a fused disconnect (installed by your electrician) to the main power terminal in the chiller's electrical enclosure.

- ☑ Electrical connections must comply with all applicable electrical codes.
- ☑ The chiller must be grounded in accordance with NEC Article 250.
- ☑ Voltage must be within 10% of the chiller's nameplate rating.

2-2 Process Water Connections

- ☑ All external chilled water connections to the process must be of adequate size.
- ☑ See Figure 6 on Page 18 for sizing recommendations.
- ☑ The largest possible openings and passages should be provided for the flow of chilled water through platens, dies, molds or other pieces of equipment.

Important!

Keep any pressure drop in external process piping to an absolute minimum for optimum unit operation.

To Process

Connect the **TO PROCESS** chilled water supply outlet to the process being cooled.

From Process

Connect the **FROM PROCESS** chilled water return inlet to the return from the process back into the chiller for cooling and recirculation.

- ☑ Sterlco recommends a strainer on the **FROM PROCESS** return line.

Process Water Bypass

All SMC chillers have an internal bypass device (patent pending). If the process flow becomes blocked during chiller operation, this component allows water to flow through the chiller. This protects the chiller from freeze-up, excessive pressures, and pump damage, and allows other safety features to remain effective.

2-3 SMC Condenser Air Supply

SMC chillers use the surrounding air to cool the condenser.

- ☑ Condenser air entering the SMC unit should be at least 65°F (18°C). Operation with air below 65°F (18°C) can cause the low pressure cutout to shut down the chiller due to the low refrigerant pressure.
- ☑ Install the chiller in an area where there is free passage of air for condensing.
- ☑ Provide 18" (46 cm) or more clearance for the chiller's air intake.
- ☑ Make provisions to exhaust the heated air discharged from the chiller.
- ☑ Do not put the SMC unit where steam, hot air or fume exhausts will be drawn into the condenser.
- ☑ Air-cooled condensers must be cleaned frequently. Neglect reduces capacity, increases operating costs, and leads to possible chiller failure. See Chapter 7 on Page 31 for cleaning instructions.
- ☑ Normal condensing pressure with 95°F (35°C) air is approximately 180 psi (1,241 kPa) for the SMC050A and SMC100A; 275 psi (1,897 kPa) for the SMC150A.

SMC Ambient Temperature Ranges

Ambient temperature range	Minimum temperature	Maximum temperature
Operation	65°F (18°C)	100°F (38°C)
Storage	40°F (4°C)	120°F (49°C)

2-4 Water Reservoir

During startup and when additional solution is required, see Figure 5 on Page 17 for the recommended ethylene glycol/water solution. This chart shows the proportions needed to provide freeze protection to 20°F/°C below the desired process setpoint.

- ☑ Add a pre-mixed solution to provide freeze protection to a temperature 20°F/°C below the normal operating temperature of the chiller.
- ☑ Use industrial quality (**not** automotive) ethylene glycol.

- ☑ A corrosion inhibitor suitable for the materials in the system should be added to the glycol/water solution.
- ☑ If straight water use is desired, contact the Sterlco Engineering Department.
- ☑ The six gallon (23 liter) reservoir is **not** designed to withstand water pressure above 5 psi (34 kPa).
- ☑ The fill opening and vent line must be vented to the atmosphere for proper operation.

Figure 5
Ethylene Glycol Curve

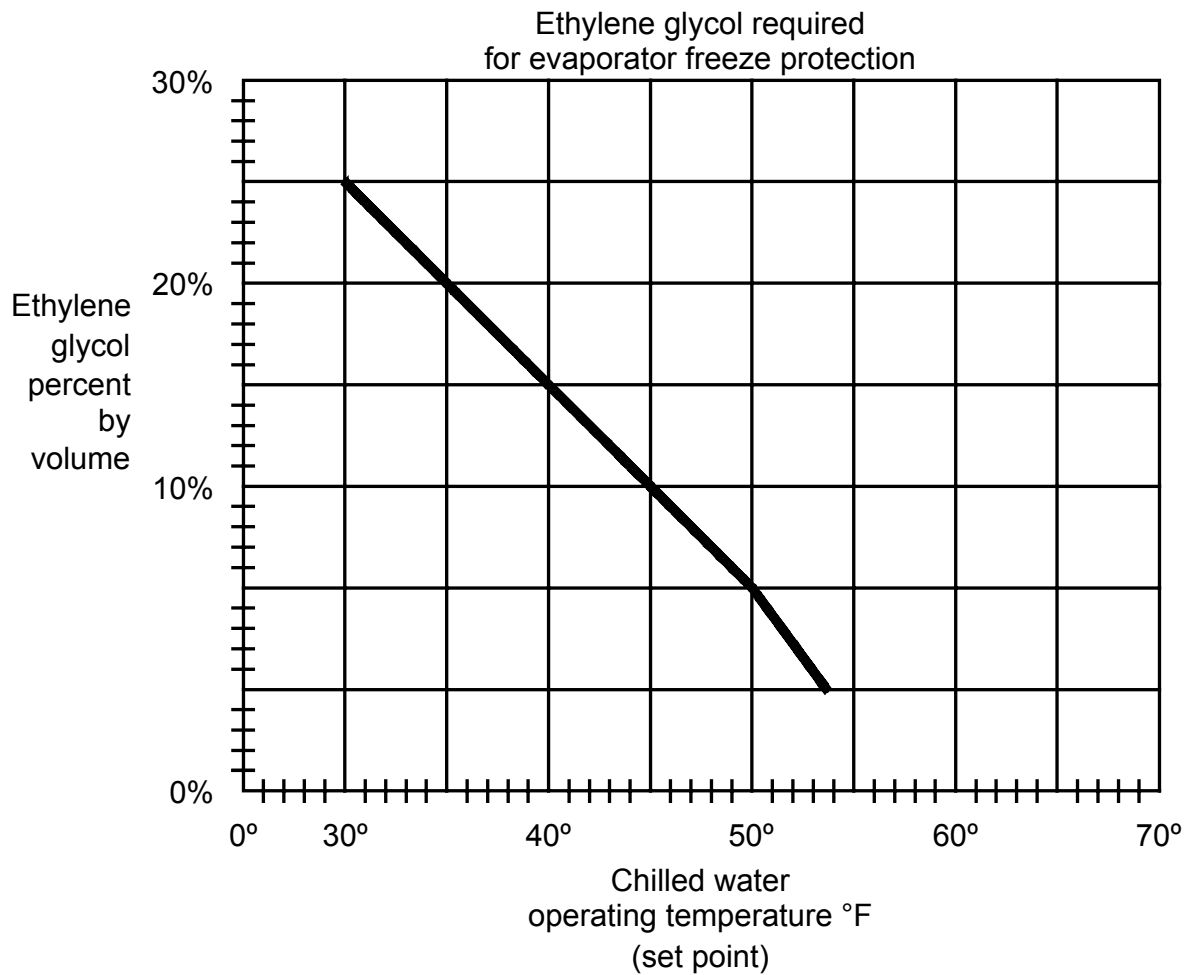

2-5 Overhead Process Considerations

If your application has chilled water or process piping above the reservoir fill and vent level, install a standpipe to a point 1' (30 cm) above the highest point in the system.

In applications where the process or its piping is 15 feet (4.6 m) or more above the reservoir, you must take steps to prevent over-pressurization of the reservoir. This condition can occur on system shutdown when the water in the system drains into the reservoir.

To prevent this, install a check valve in the unit **TO PROCESS** line and a vacuum breaker at the high point of the return **FROM PROCESS** line. See Figure 6 on Page 18 for more information.

Note: The reserve capacity of the reservoir can hold a volume equal to **20 feet (6.1 m) of 1-inch (2.5 cm) pipe.**

Figure 6
Overhead Piping

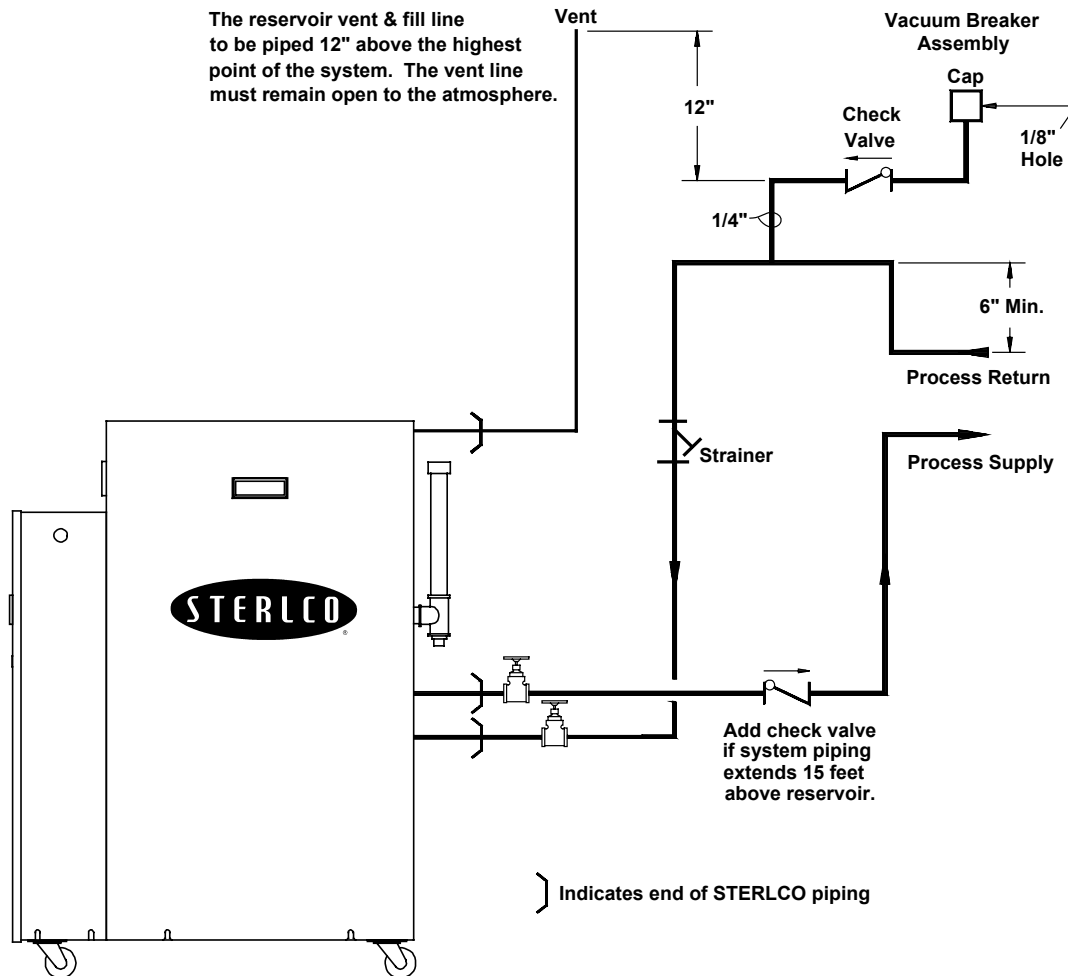

Important!

- The SMC unit has a leaving water temperature range of 30°F (-1°C) to 65°F (18°C). Do not attempt to run the SMC unit outside this temperature range or damage to the unit may occur.
- When operating the SMC unit between 30°F (-1°C) and 40°F (5°C), you must use a solution of 75% water and 25% industrial-grade ethylene glycol with a suitable corrosion inhibitor to protect the SMC unit from freeze-up. See Figure 5 on Page 17 for more information. Such damage is not covered by the Sterlco warranty.

3-1 Chilled Water Circuit

Figures 8, 9, and 10

- ☑ Process cooling water supply and return connections are made at the pipe stubs at the rear of the chiller.
- ☑ Warm water returns from the process and enters the reservoir tank.
- ☑ The process water is pumped through the evaporator where it is cooled.
- ☑ The coolant flows to the process and returns to repeat the cycle.
- ☑ A chilled water bypass assembly (patent pending) between the supply and return lines guarantees a constant flow through the evaporator during intermittent low or no-flow conditions.
- ☑ A flow switch in units without pumps will prevent the compressor from running without adequate flow through the evaporator

3-2 Refrigeration Circuit

- Liquid refrigerant from the condenser passes through a filter/dryer which removes moisture and other contaminants.
- The refrigerant then passes through the thermal expansion valve which allows the refrigerant to expand and cool the inside of the heat exchanger. The refrigerant flows through the suction line to the compressor.
- The refrigerant gives up its heat as it re-condenses to a liquid in the condenser and the cycle starts over again.

3-3 High Pressure Cutout

The high pressure cutout is an electro-mechanical safety feature that opens the control circuit if the system condensing pressure exceeds a safe level. The chiller will automatically restart when the pressure drops back to an acceptable level.

Model	Cuts out if condensing pressure exceeds:
SMC050A	275 psi (1,897 kPa)
SMC100A	275 psi (1,897 kPa)
SMC150A	400 psi (2,759 kPa)

Important!

Call a refrigeration service technician to analyze the problem if high pressure recurs.

3-4 Low Pressure Cutout

The low pressure cutout is an electro-mechanical safety feature that prevents compressor suction pressure from dropping below a preset point.

It is factory set to open the control circuit when pressure drops below a safe level. The chiller will automatically restart when the suction pressure reaches an acceptable level.

Model	Cuts out if suction pressure falls below:
SMC050 A	15 psi (103 kPa)
SMC100 A	15 psi (103 kPa)
SMC150 A	35 psi (241 kPa)

3-5 Remote Start/Stop Interlock

A contact is provided to allow interlocking of the SMC Series Chiller with process controls. To use this feature, remove the jumper between Terminals X1 and 1 on Terminal Block 1. Supply a switch or dry contact interlock connected in series between these two terminals. See Figures 14 and 15 on Pages 32 and 33 for more information.

Figure 7
SMC Component Identification

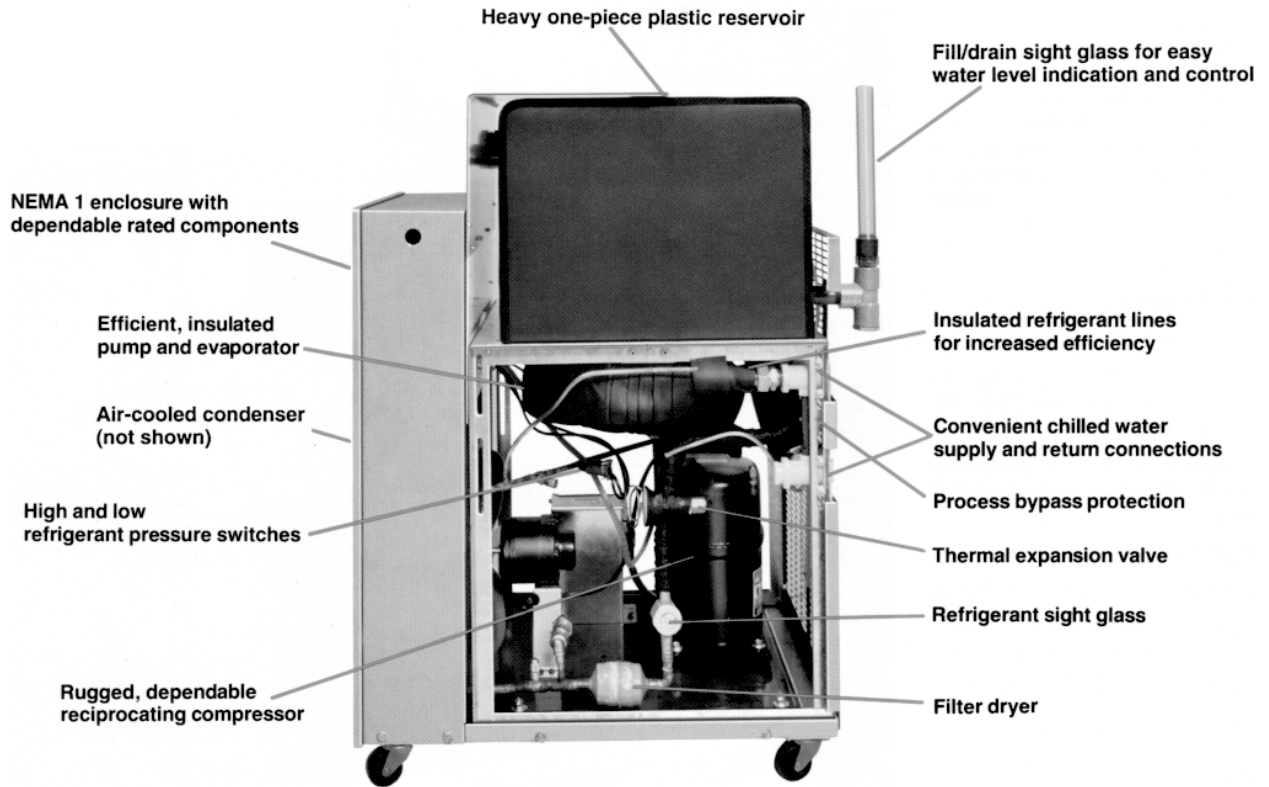

Figure 8
Piping Schematic — 1 Pump with Reservoir

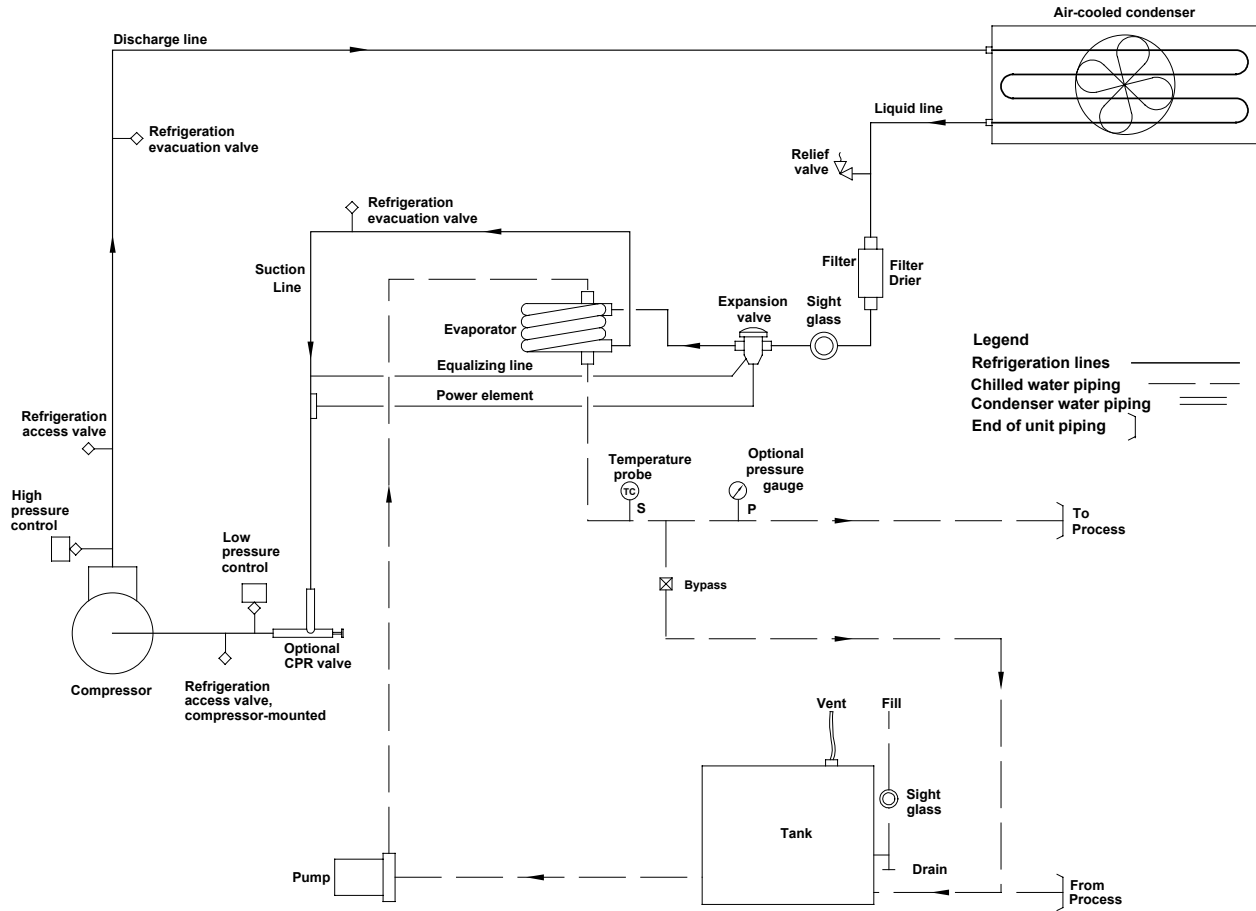

Figure 9
Piping Schematic — 1 Pump without Reservoir

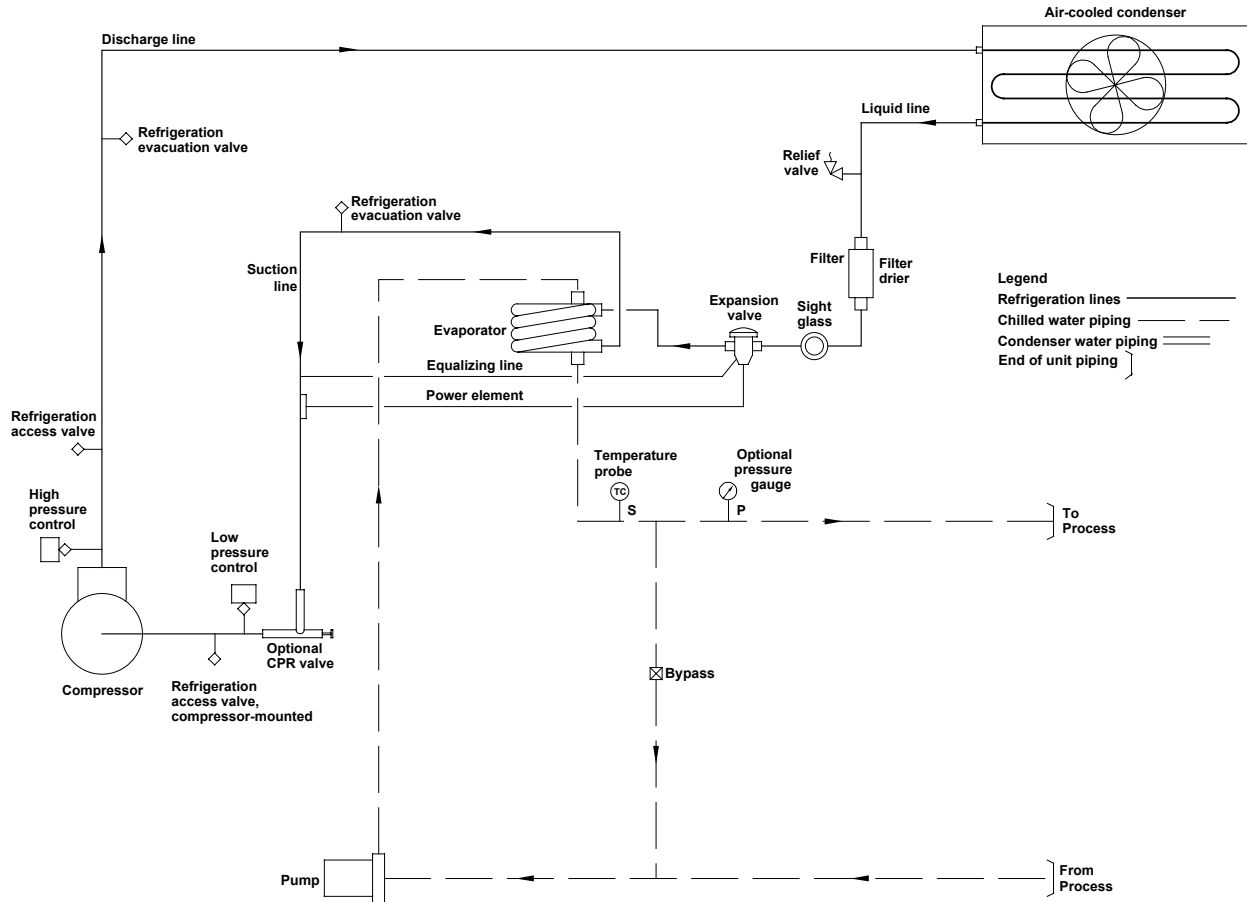
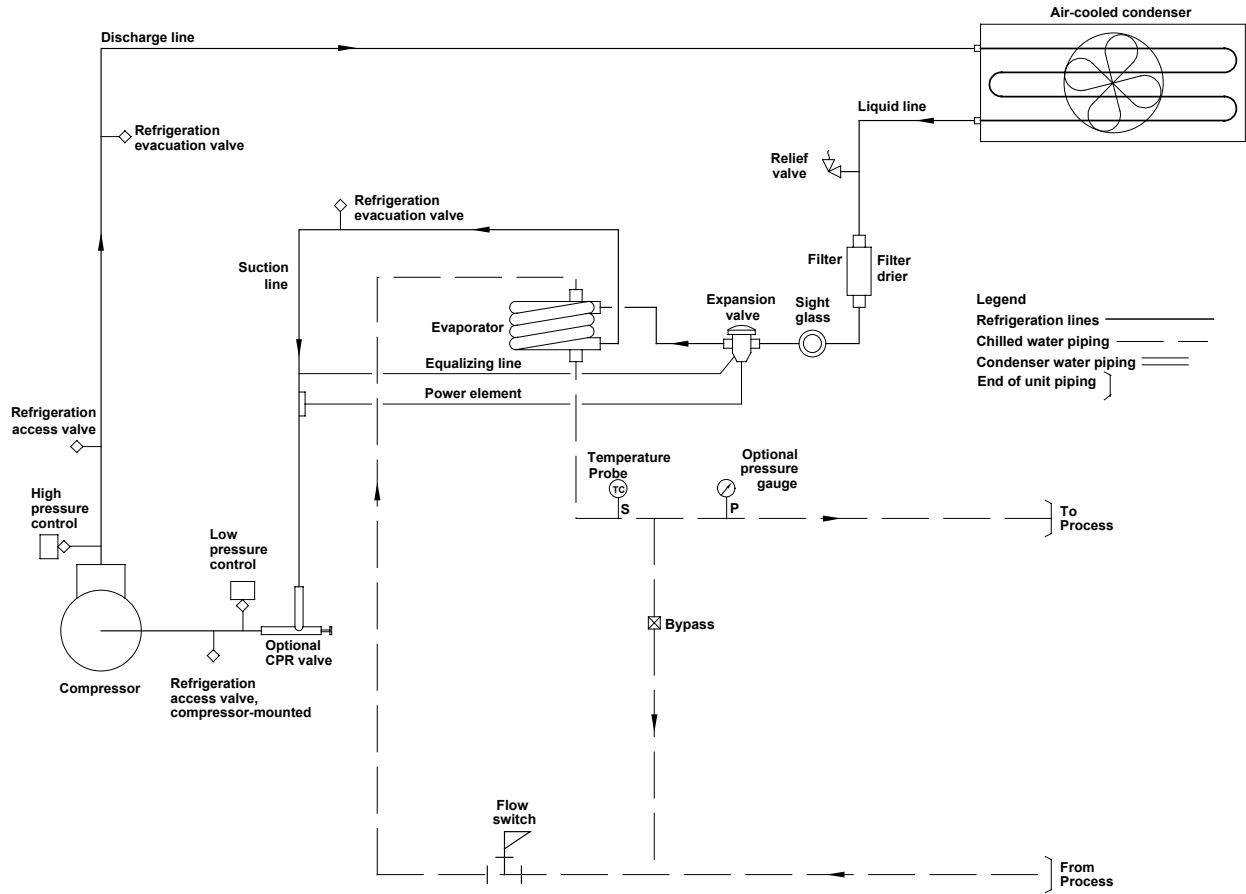

Figure 10
Piping Schematic — No Pump, No Reservoir



4-1 Introduction

Follow the check lists below for the startup of your new chiller. These lists assume the installation information elsewhere in this manual has been read and followed. New chillers should be started up and checked by a qualified refrigeration service technician.

4-2 SMC Pre-Startup Checklist

1. Check the shipping papers against the serial tag to be sure chiller size, type and voltage is correct for the process that will be controlled.
2. Check the transformer primary voltage connections to be sure they are configured for the electrical power you are using. The voltage at the main power connection must read within +/-10% of the voltage listed on the serial tag. Electrical connections must conform to all applicable codes.
3. The chilled water **TO PROCESS** and **FROM PROCESS** connections should be completed.
4. Be sure the reservoir tank and chilled water circuit piping are filled with water.
5. The air-cooled condenser should have an adequate supply of air for proper operation.
6. Connect main power to the chiller and run the chiller just long enough to see if the pump is generating normal pressure.
7. Check your work and proceed to the **SMC Startup Checklist** section below.

4-3 SMC Startup Checklist

1. Turn **ON** the chiller. The SMC chiller should continue to run until the switch is turned **OFF**.
2. Put the SMC chiller under a process load.
3. Set the microprocessor control to the desired process temperature setpoint using the  buttons. See Chapter 5 on Page 27 for more information.
4. Check the pump amp draw and pump pressure. The amp draw reading must be within the running load and service factor amps.
5. Operate the chiller, looking for leaks and listening for unusual noises or vibrations that could indicate improper operation.



Figure 11
SMC Water Circuit Pressure Drop Table

Model	Gallons per minute	ΔP (psig)
SMC050A	2.0	2.5
	2.4	4.0
	3.6	7.5
	4.8	12.5
SMC100A	2.0	2.5
	2.4	2.5
	3.6	3.0
	4.8	5.0
SMC150A	2.0	2.5
	2.4	2.5
	3.6	3.0
	4.8	3.5

5-1 Introduction

Standard SMC Series chillers use a microprocessor based controller. The controller is a modular, self-contained unit that can slide from its mounting housing. It is factory set and adjusted; no field adjustment to the internal controls is necessary.

5-2 Setting the Process Water Temperature

- Press  until the **SP** indicator lights.
- Press  or  to raise or lower the setpoint to the desired leaving water temperature.

Note: SMC leaving water temperature range of operation is 30°F (-1°C) to 65°F (18°C).

- Press  to display the current process temperature (**SP** and **AL** are off).

5-3 Setting the Alarm Value





- Press  until **AL** lights.
- Press  or  to raise or lower the alarm value. The factory setting is **10**, and should be correct for most processes. Setting the alarm value to **10** creates an alarm if the process temperature rises or falls 10°F/°C or more from the chiller process setpoint.
- Press  to display the current process temperature (**SP** and **AL** are off).

Figure 12
SMC Control



6-1 Indicator Lights

PUMP ON (green)

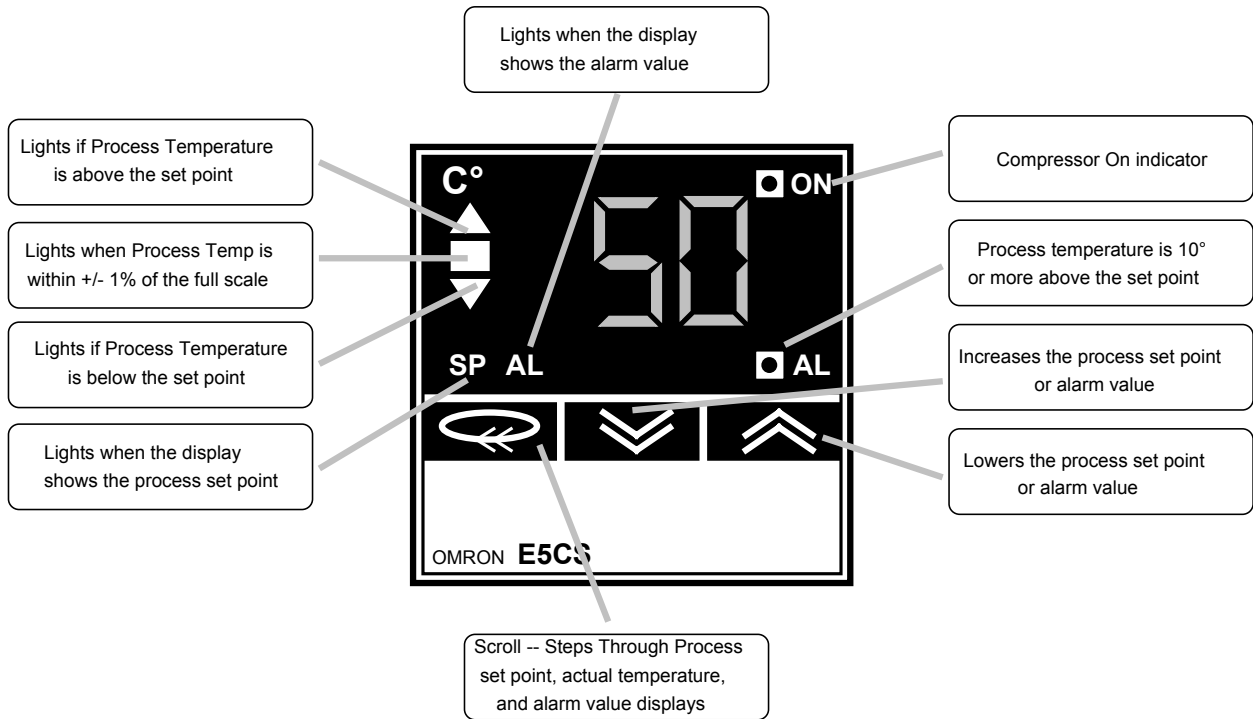
This indicator is lit when the pump runs.

COMPRESSOR ON (green)

This indicator is lit when the compressor operates.

HIGH REFRIGERANT PRESSURE (red)

This indicator lights if the condensing pressure exceeds a safe level. The chiller goes to Idle mode until the high refrigerant pressure cutout resets. The light then goes out and the chiller automatically restarts. Call a qualified refrigeration service technician for service.

LOW REFRIGERANT PRESSURE (red)

This indicator lights if the refrigerant pressure drops below a safe level. The compressor will stop and remain off until the pressure reaches a safe level. The light will go out and the chiller will then resume operation automatically.

LOW WATER FLOW (red), SMC units without pump only

This indicator lights if the flow switch senses chilled water/glycol flow through the evaporator dropping to an unacceptable level. The compressor will stop until the flow switch senses adequate flow and restarts the chiller.

6-2 Switches

POWER

This switch energizes the control circuit; it also turns off the chiller.

Figure 13
Optional Graphic Panel

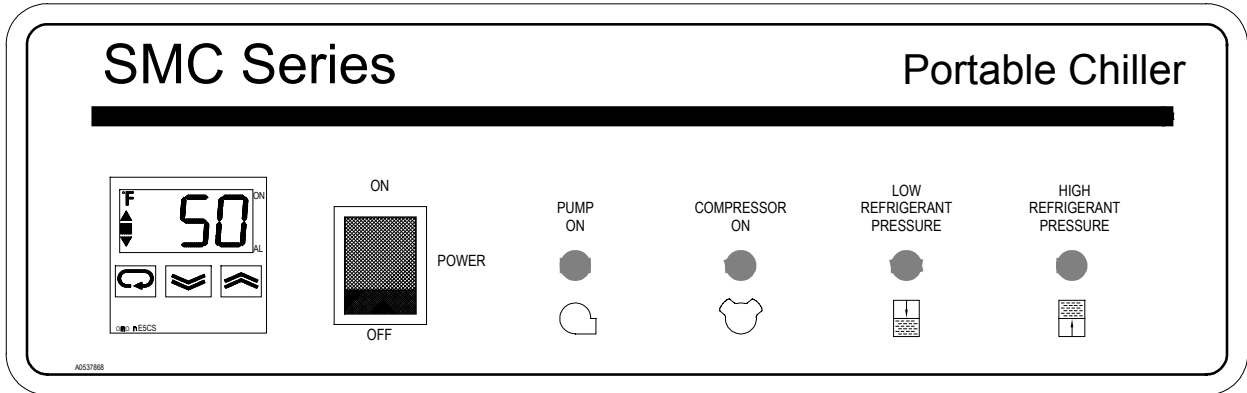

7

Routine Maintenance

7-1 Lubrication

Every three months, grease all fan motors and pump motors that do not have permanently sealed bearings. Remove grease relief plug (motors only) before adding grease. Failure to do so may result in dislodging the bearing grease retainer, eventually causing bearing failure.

Compressors are hermetically sealed; no oiling is required.

7-2 Condenser Maintenance

Dirty condenser heat exchange surfaces reduce system capacity.

Brush or vacuum light dirt accumulations. Avoid bending or damaging the fins. Heavy soil accumulations on the coil require professional steam cleaning; washing from the outside only makes matters worse.

Figure 14
Typical SMC Subpanel

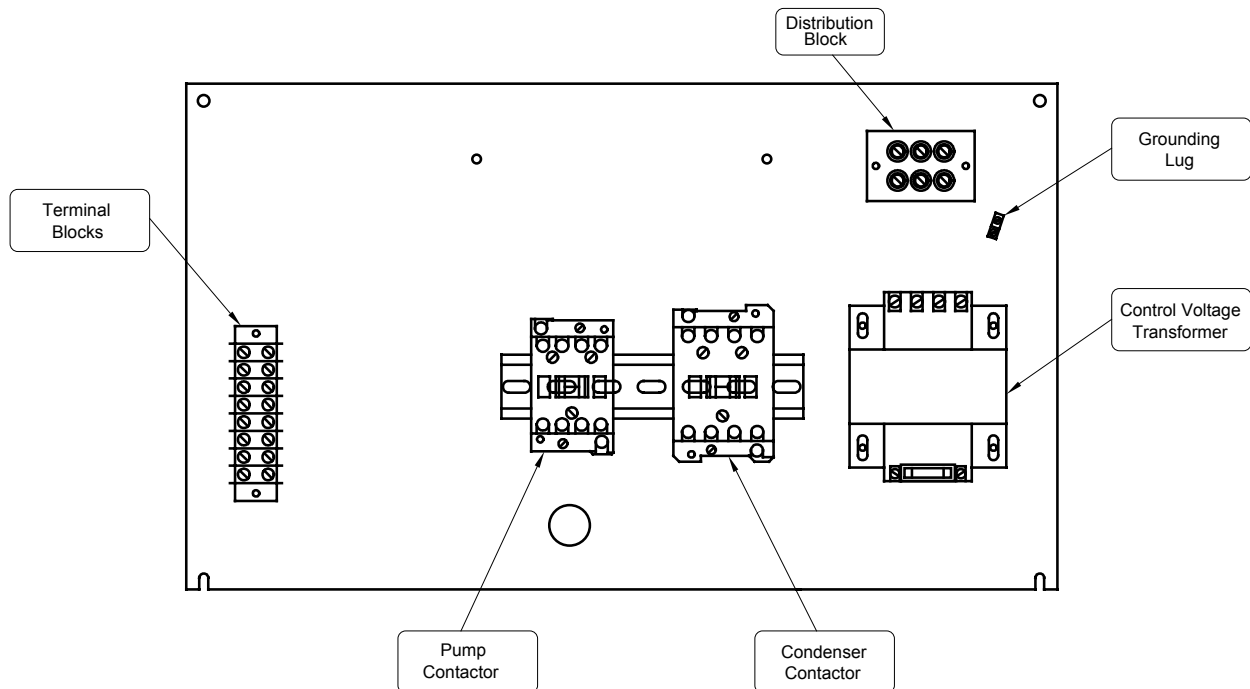

Figure 15
Typical SMC Wiring Schematic

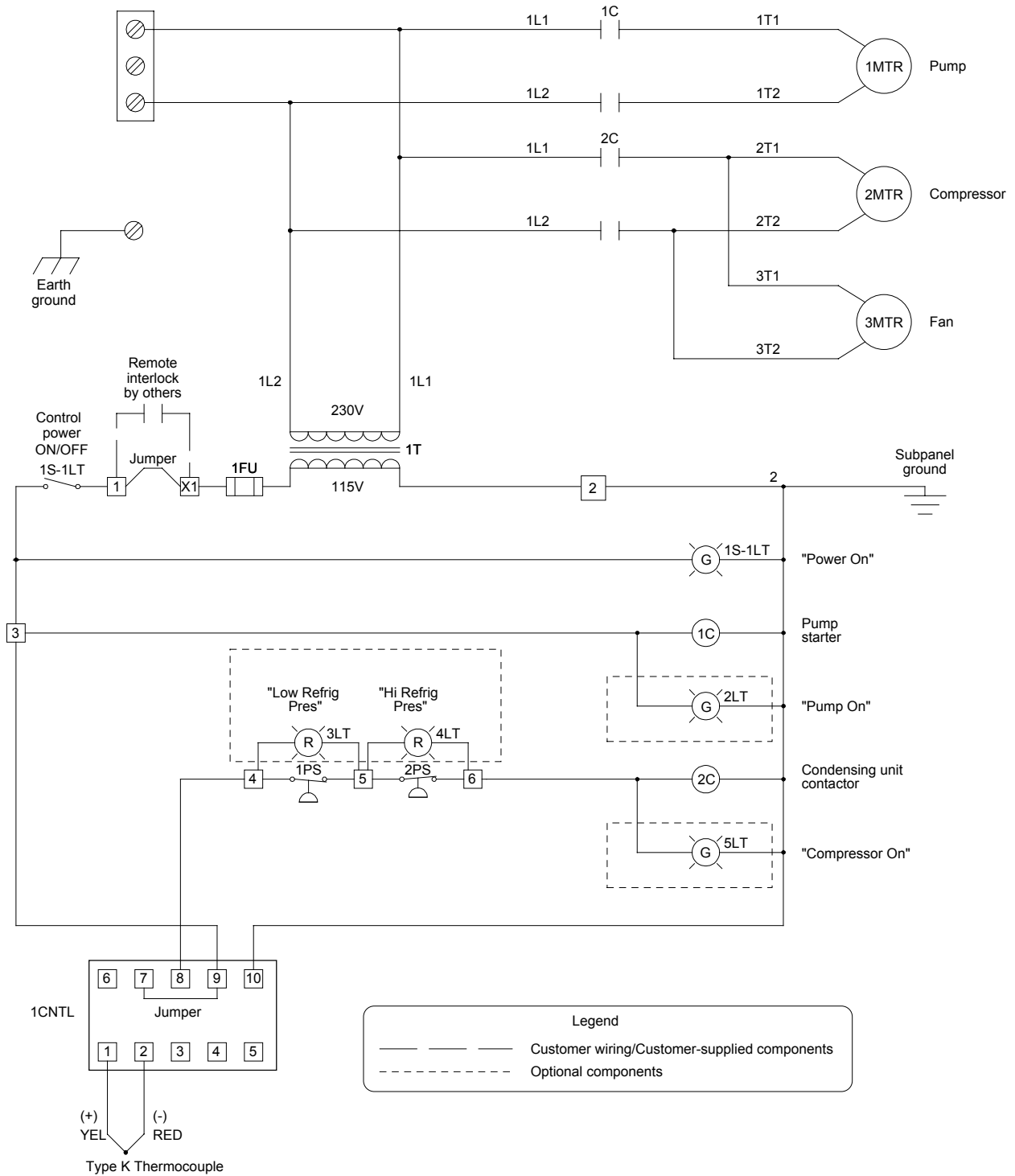
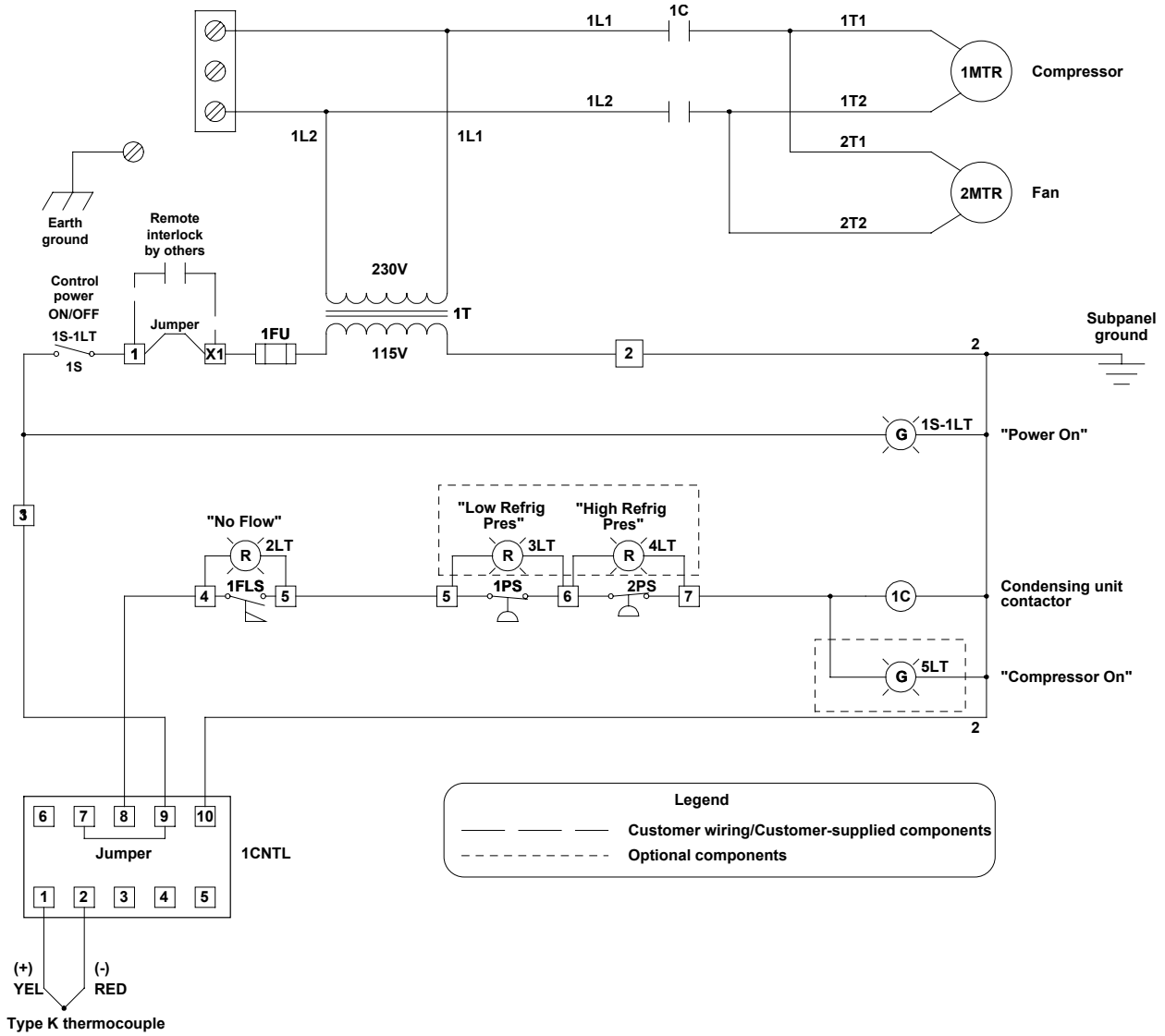

Figure 16
 SMC Wiring Schematic for Chillers with No Pump or Reservoir



- Notes -

Problem	Possible cause	Solution
Chiller will not run.	No power.	Check main disconnect fuses, wiring, and power lead to the unit.
	Wrong voltage supplied to the chiller.	Voltage must be within plus or minus 10% of the nameplate rating.
	Defective on/off switch.	Replace.
	Control circuit fuse blown.	Replace, check the transformer.
	Defective control transformer.	Replace.
Pump runs, compressor cycles at short intervals.	No process load on the chiller.	Increase the process load.
	Refrigerant is low.	Check the refrigerant charge.
The leaving water temperature is too high.	Refrigerant is low.	Check the refrigerant charge.
	Improper water/glycol solution.	Make sure that the coolant solution is right for the process — must be 75% water and 25% glycol. See Figure 5 on Page 17 for more information.
Pump pressure is low (see pump curves).	Check for foreign matter.	Clean the system.
Pump pressure is too high.	Restricted water flow.	Check for partially closed valves, etc. Be sure all lines are properly sized.

Problem	Possible cause	Solution
Pump runs, compressor will not.	Refrigerant is low.	Check the refrigerant charge.
	Pressure switch contacts are open.	Sight glass should be clear while compressor runs. Call for service if bubbling or foaming.
	Refrigerant high pressure cutout switch contacts are open.	Check for dirty condenser. Check for condenser air obstruction.
	Defective fan motor.	Repair or replace.
	Compressor internal overload is open. Allow time to cool and reset.	Check for high/low voltage. Must be within plus or minus 10% of the nameplate rating. Check for poor compressor electrical connections.
	Broken wire in the compressor control circuit.	Locate and repair.
Unit runs continuously, but not enough cooling power.	Restricted condenser airflow.	Clean the condenser.
	Unit low on refrigerant.	Call Service.
	Inefficient compressor.	Call Service.
	Unit undersized for application.	Call Sales Representative.

Figure 17
SMC Spare Parts List

Part number	Description
A0537868	SMC graphic
A0537899	BZ pressure gauge
A0534584	Red neon graphic light *
A0534586	Green neon graphic light *
A0500857	2" swivel casters
A0534269	1/16 DIN digital temperature controller
A0537955	Process water flow switch
A0533873	Thermocouple, 8'
A0539409	150 VA transformer
A0103778	Rubber feet
A0537900	Tank sight glass assembly
A0537908	Handles
A0537915	SMC050A-SMC100A low refrigerant pressure switch
A0543063	SMC150A low refrigerant pressure switch
A0537916	SMC050A-SMC100A high refrigerant pressure switch
A0537917	SMC150A high refrigerant pressure switch
A0501642	SMC050A-SMC100A high refrigerant pressure safety relief valve
A0104093	SMC150A high refrigerant pressure safety relief valve
A0537974	Bronze Y strainer

* Units with the optional SMC graphic panel.

Service Notes

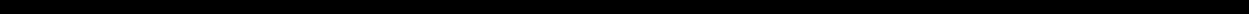

A series of 25 thin, horizontal black lines spaced evenly down the page, providing a ruled area for writing service notes.

Service Notes



Lined area for service notes, consisting of multiple horizontal lines.



Parts Department

Call toll-free 7am–6pm CST [800] 783-7835 or call [414] 354-0970

The Sterling/Sterlco Parts Department at Sterling, Inc. is ready to provide the parts to keep your systems up and running. Sterling/Sterlco replacement parts ensure operation at design specifications. Please have the model and serial number of your equipment when you call. Consult the Customer Parts List included in your information packet for replacement part numbers.



Service Department

Call toll-free 8am–5pm CST [800] 783-7835 or call [414] 354-0970

Emergencies after 5pm CST, call [847] 439-5655

Sterling/Sterlco has a qualified service department ready to help. Service contracts are available for most Sterling/Sterlco products.



Sales Department

Call [414] 354-0970 Monday–Friday, 8am–5pm CST

Sterling/Sterlco products are sold by a world-wide network of independent sales representatives. Contact our Sales Department for the name of the sales representative nearest you.

Sterling

Sterling/Sterlco
5200 West Clinton Avenue
Milwaukee, WI 53224-9518
[414] 354-0970 • Fax [414] 354-6421