

BOSCH

Use and Care Manual

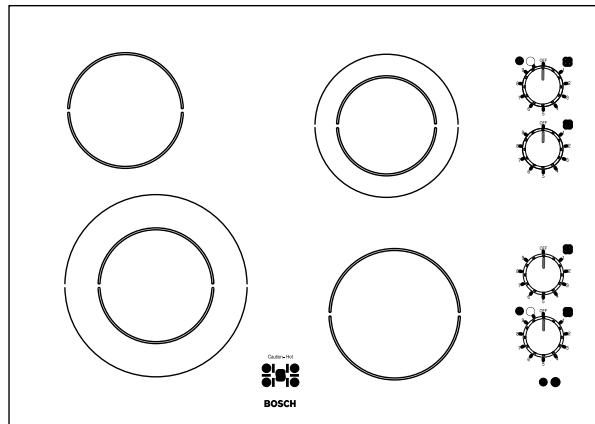

NEM73UC

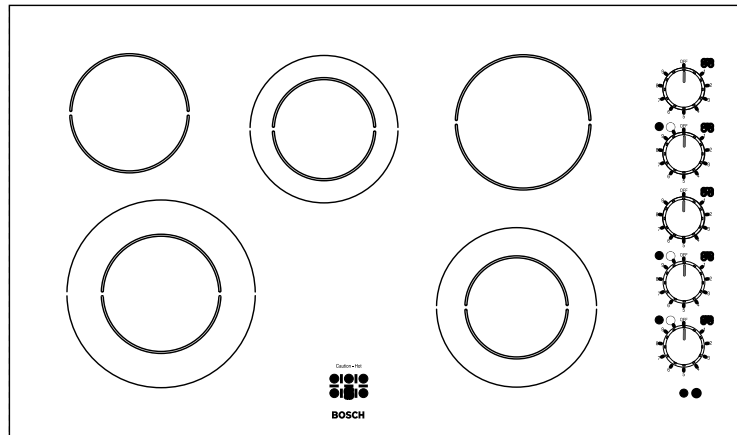

NEM93UC

Bosch Glass Ceramic Cooktops

Models: NEM73UC, NEM93UC

Dear Bosch Cooktop Owner

Thank you for selecting the Bosch Glass Ceramic Cooktop. We recommend that you take time to read this manual prior to using your cooktop for the first time.

This booklet contains suggestions that will be helpful as well as directions for using all the features on your cooktop. Keep it handy as it has answers to the questions that may come to mind when you start to cook.

The information in this manual will help you easily operate and care for your cooktop for years of satisfaction.

If you have any questions, please contact us at 1-800-944-2904. For additional information, visit our website at www.boschappliances.com or write to us at:

BSH Home Appliances Corp.
BOSCH
5551 McFadden Avenue
Huntington Beach, CA 92649

Sincerely,
Test Kitchen Consumer Scientists

Table of Contents

Important Safety Instructions	1-2	Heat Settings for Radiant Elements	7
Cooktop Models	3	Cleaning Guide	8
Operating Instructions	4	Before Use Care	8
Before Using Cooktop for First Time	4	Knobs	8
Precautions for Long Life and		Recommended Cleaners	8
Good Appearance of the Surface	4	Avoid These Cleaners	8
Indicator Lights	4	Daily Cleaning Techniques	8
Retained Heat	4	How to use a Razor Blade Scraper	8
White Cooktops	4	Special Care Chart	9
The Elements/Setting the Controls	5	Troubleshooting	10
Radiant Elements	5	Bosch Cooktop Warranty	11
Single Element	5		
Dual Element	5	Packaged with Cooktop	
Temperature Limiters	5	Use and Care Manual	
Using Proper Cookware	6	Installation Instructions	
Cookware Characteristics	6	Cooktop Cleaning Creme®	
Testing the flatness of your pans:	6	Razor Blade Scraper	
Specialty pans	6	Mounting Brackets	
Cookware Tips	6	Registration Card	
		Foam Tape Seal	

Note: The Bosch cooktop referred to throughout this manual is manufactured by BSH Home Appliance Corp.



IMPORTANT SAFETY INSTRUCTIONS



READ ALL INSTRUCTIONS BEFORE USING YOUR COOKTOP

If the information in this manual is not followed exactly, a fire or explosion may result causing property damage, personal injury or death.

PERSONAL SAFETY



WARNING — TO REDUCE THE RISK OF INJURY TO PERSONS, IN THE EVENT OF A GREASE FIRE, OBSERVE THE FOLLOWING:

- In the event of a grease fire **SMOTHER FLAMES** with a close-fitting lid, cookie sheet, or other metal tray, then turn off the gas burner. **BE CAREFUL TO PREVENT BURNS.** If the flames do not go out immediately, **EVACUATE AND CALL THE FIRE DEPARTMENT.**
- Do not use water, including wet dishclothes or towels on grease fires. A violent steam explosion may result.
- **NEVER PICK UP A FLAMING PAN.** You may be burned.
 - **ALWAYS** have a working **SMOKE DETECTOR** near the kitchen.
 - **LEAVE THE HOOD VENTILATOR ON** when flambéing food.
- Use an extinguisher **ONLY IF:**
 - You know you have a Class ABC extinguisher, and you already know how to operate it.
 - The fire is small and contained in the area where it started.
 - The fire department is being called.
 - You can fight the fire with your back to an exit.
 - **SMOTHER FLAMES** from other types of food fires with baking soda. **NEVER** use water on cooking fires.



WARNING

TO REDUCE THE RISK OF FIRE, ELECTRIC SHOCK, OR INJURY TO PERSONS, OBSERVE THE FOLLOWING:

- Use this unit only in the manner intended by the manufacturer. If you have any questions, contact the manufacturer.
- Before servicing unit, switch power OFF at service panel and lock service panel to prevent power from being switched on accidentally.
- Do not cook on a cooktop in which the glass top has broken. If the cooktop glass should break, do not use it or attempt to clean or fix it. Cleaning solutions and spill overs may penetrate the broken cooktop and create a risk of electric shock. Turn off electric circuit to the cooktop and call an authorized service agency immediately.
- Do not store items of interest to children above the cooktop or at the back of it. If children climb onto the cooktop to reach these items, they could be seriously injured.
- Children and pets should not be left alone or unattended in an area where appliances are in use. They should never be allowed to sit or stand on any part of appliance.



WARNING

DO NOT STORE FLAMMABLE MATERIALS ON OR NEAR THE COOKTOP.

- When using the cooktop, **DO NOT TOUCH THE HOT COOKING AREA OR THE IMMEDIATE SURROUNDING AREA.** Even though dark in color, these areas may be hot. Areas adjacent to the elements may become hot enough to cause burns. Never let clothing, pot holders, or other flammable materials come in contact with a cooking area until it has cooled.
- For personal safety wear proper apparel. Loose fitting garments or those with long, loose sleeves should never be worn while cooking. Tie long hair so that it doesn't hang loose.

! IMPORTANT SAFETY INSTRUCTIONS !

Read all instructions before using your cooktop

- Use only dry potholders. Moist or damp pot holders on hot surfaces may cause burns from steam. Do not use a towel or other bulky cloth in place of potholders. Do not let potholders touch hot cooking areas.
- This appliance is equipped with one or more surface units of different sizes. Always use utensils that have flat bottoms and that are large enough to cover the whole cooking area. The use of a utensil smaller than the size of the cooking area will expose a portion of the heated area to direct contact with the user which could result in burns. Proper relationship of utensil to burner will also improve efficiency.
- Turn handles of utensils inward so that they do not extend over adjacent work areas, cooking areas, or the edge of the cooktop. This will help prevent hot food spills, risk of burns and ignition of flammable materials, and preventing access by children.
- The cooktop is for cooking. Never use it to warm or heat a room.
Be sure your appliance is properly installed and grounded by a qualified servicer in accordance with the Installation Instructions provided with the cooktop.
Do not repair or replace any part of the appliance unless specifically recommended in this manual. All other servicing should be referred to a qualified servicer.
- Always use cookware and utensils appropriate for the type and amount of food being prepared.
- Do not place any hot cookware on the control panel area.
- Use high heat settings on the cooktop only when necessary. Use low to medium settings to heat oil slowly.
- Never move a pan of hot oil, especially a deep fat fryer. Wait until it is cool.
- Never leave the cooktop unattended when using high heat settings. Boilovers can cause smoke and possibly damage the cooktop.
- Hold the handle of the pan to prevent movement of the utensil when stirring or turning food.
- Other than the use of metal pans, only certain types of glass, heatproof glass ceramic, ceramic, earthenware, or other glazed utensils are suitable for cooktop use. These types of utensils may break with sudden temperature changes. Use only on low or medium heat settings according to the utensil manufacturer's directions.
- Clean the cooktop with caution. If the soil must be removed while the cooktop is hot, clean the hot top with the metal razor blade scraper only. Do not use a wet sponge or cloth while it is hot. Some cleaners produce noxious fumes if applied to a hot surface.
- Clean the ventilation system above or behind the cooktop frequently, so that grease from the cooking vapors does not accumulate on the filters, fan, intake, or hood.

Save These Instructions

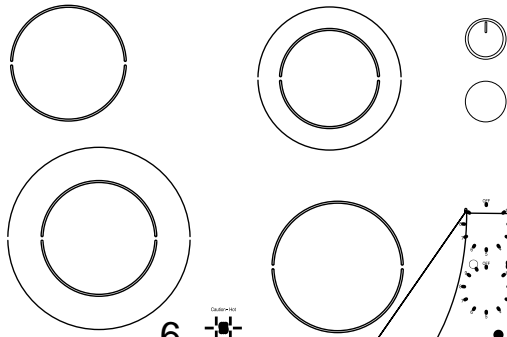

6
GALLENKUPF
BOSCH

NEM73UC

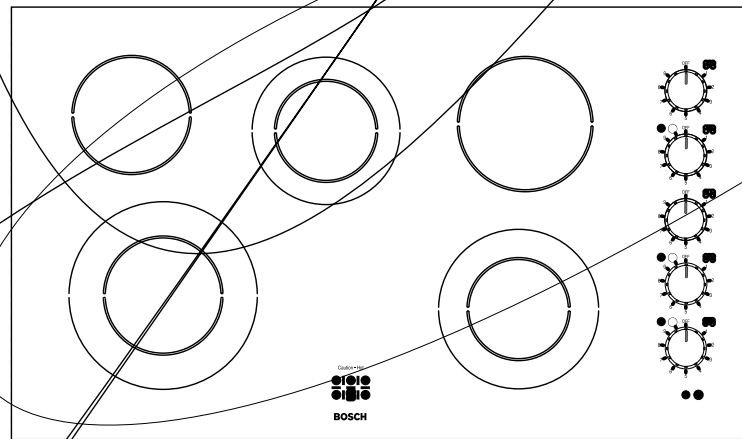

GALLENKUPF
BOSCH

NEM93UC

8

Cooktop Operating Instructions

BEFORE USING THE COOKTOP FOR THE FIRST TIME

- Remove all packing materials and literature from the cooktop surface.
- While cool, wipe with a clean, damp sponge and dry.
- Apply the Cooktop Cleaning Creme® packaged with the cooktop. Buff with a clean cloth. (See Page 8 for daily care instructions.)
- There may be a slight odor during the first several uses; this is normal and will disappear.
- Optimum cooking results depend on the proper cookware being selected and used. (See Page 6.)
- The cooking surface will hold the heat and remain hot up to 25 or 30 minutes after the elements have been turned off.
- Read all safety precautions and Use and Care Manual information prior to operating.

Precautions for Long Life and Good Appearance of the Surface

- Regular, daily care using the Cooktop Cleaning Creme® will protect the surface and make it easier to remove food soil and water spots.
- The glass ceramic cooking surface is a durable material resistant to impact but not unbreakable if a pan or other object is dropped on it.
- Do not use aluminum foil directly on the glass; it will melt and damage the glass surface.
- Do not allow plastic, paper, or cloth to come in contact with the hot glass surface; these items can melt or burn and damage the glass surface.
- Do not allow pans to boil dry. This can damage the pan, element and/or the cooktop.
- Never cook food directly on the glass.
- Avoid placing a wok support ring, trivet or other metal stand on the glass surface.
- Do not use the glass surface as a cutting board.
- Do not slide cookware across the cooking surface; it may scratch the glass.
- Do not place wet pans on the glass surface.

Indicator LIGHTS

Element 'ON' Indicator Light

The element "ON" indicator light glows whenever any element is turned on. The light remains lit until all of the elements are turned off.

The "ON" light is located in front of the control knobs.

For dual elements there is an additional "ON" indicator light located at the top left of the control knob. This light glows when both the inner and outer elements are being used and the element is on. When using a setting other than 9 (High), the light will cycle on and off as the element cycles.



Hot Surface Indicator Light

Each element features a hot indicator light to show when the cooking surface is too hot to touch. The signal light will turn on automatically in the area marked Caution - Hot at the center front. The light remains on until the cooking area has cooled to a safe-to-touch temperature.

If a hot surface light is on, use caution when working or cleaning around the cooktop as the cooktop is still hot.

CAUTION - HOT

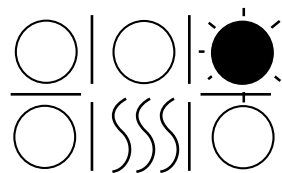

Retained Heat

The glass cooking surface retains heat and stays hot after the element(s) have been turned off. The retained heat may be used to hold foods at serving temperatures for a short time.

Note for Owners of White Cooktops: When an element is hot, there is a light green tint on the cooking surface. This is normal and will disappear after several minutes as the surface cools down.

Control Knobs

The controls on the cooktop are marked to show which element they control. All controls are marked from 1-9, with 1 being the lowest heat setting and 9 the highest setting.

The Elements / Setting the Controls

Radiant Elements

This type of electric element uses a wire ribbon located under the glass-ceramic surface to provide the heat for cooking. Radiant elements will cycle on and off by design (see *Temperature Limiters*, below.) There are an infinite number of heat settings between the 1-9 positions.

Single Element

To turn on a single element, push down on the control knob and turn in either direction to the desired heat setting.

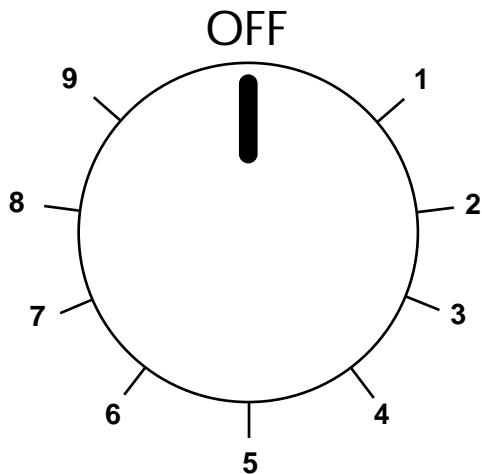

Single Element Control Knob

Dual Element

The dual element consists of two radiant ribbon elements within the same heating area. Either the small inner element or both the inner and outer elements may be selected for use.

To turn ON the small, inner element, push down on the control knob and turn it clockwise. Use the control as if it was a single element.

To turn ON both the inner and outer elements together, push down on the control knob and turn it clockwise past the number 9 setting to the dual element marker. The dual ON indicator light will glow indicating that the dual element is on. Turn the knob counterclockwise to the desired setting. To turn off the dual element, turn the knob to the OFF position.

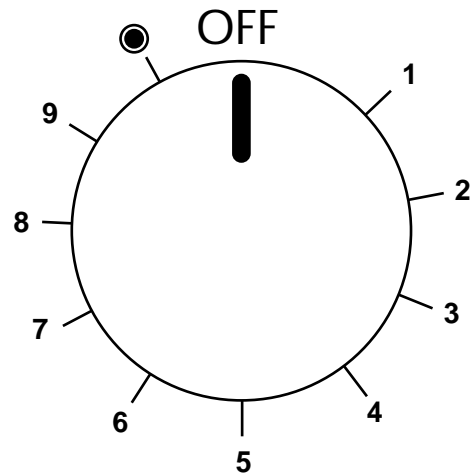

Dual Element Control Knob

Temperature Limiters

Each radiant heating element has its own sensor to protect the glass cooking surface from extreme high temperatures. The limiters will operate automatically by cycling the element off regardless of the cook setting.

Although cycling is normal, any one of the following conditions can activate the limiter and cause it to cycle on and off more than usual:

- The base of the pan is not making full contact with the heating surface (due to a warped or uneven base).
- The pan is too small for the size of the element.
- The pan has boiled dry.
- The material or shape of the pan is slow to transfer the heat.

Using Proper Cookware

Cookware Characteristics

The choice of pans directly affects the cooking speed and uniformity. For best results select pans with the following features:

FLAT BASES - When a pan is hot, the base (pan bottom) should rest evenly on the surface without wobbling (rocking). Flat, medium-to-heavy-weight pans are best.

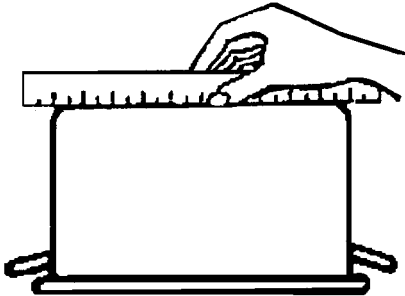

To test the flatness of your pans

Turn the pan upside down on the countertop and place a ruler flat against the bottom of the pan. The bottom of the pan and the straight edge of the ruler should be flush against each other.

Another simple test to determine even heat distribution across the cookware bottom is to place 1" water in the pan. Bring the water to a boil and observe the location of the bubbles as the water starts to boil. Good, flat cookware will have an even distribution of bubbles over the bottom surface area.

DIAMETER – The base of the pan should cover or match the diameter of the element being used. Pans may overhang the element area by 1" all around.

TIGHT FITTING LID – A lid shortens cooking time by holding the heat inside the pan.

Specialty pans

Specialty pans, such as griddles, roasters, pressure cookers, woks, water bath canners and pressure canners must have the same features as described above. (Use only a flat-bottom wok.) Never place a support ring, such as a wok ring or trivet, on the cooking surface.

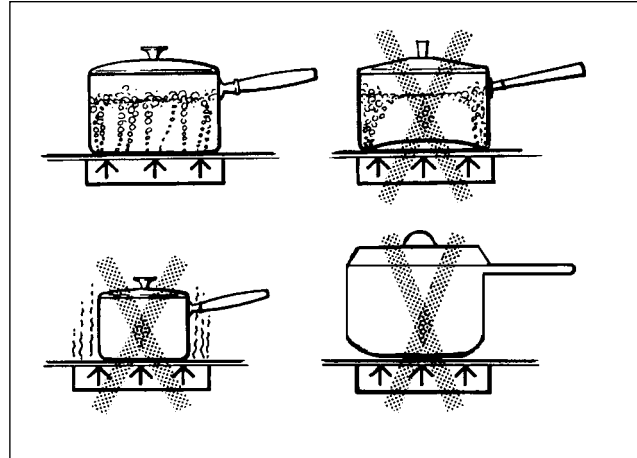

Cookware Tips

- Use of pots and pans with rounded (either concave or convex) warped or dented bottoms should be avoided. See drawings above.
- Make sure the bottom of the pot or pan being used is clean and dry.
- Use pots and pans with thick, smooth metal bottoms.
- Do not slide metal pots across the cooktop. Pans may leave marks. (See Page 9 for cleaning.)
- Do not use glass pans as they may scratch the surface.

CAUTION

- **Foods packaged in aluminum foil** should **not** be placed directly on the glass ceramic surface for cooking; aluminum foil can melt and cause permanent damage.

CAUTION

- **Plastic, paper and cloth can melt or burn** when in contact with a hot surface. Do not let these items come in contact with the hot glass ceramic surface.
- **Do not allow pans to boil dry.** This can permanently damage the pan, the element and the cooktop glass.

Heat Settings for Radiant Elements

All these settings are recommended without the element being preheated. Use this chart as a guide.

Type of Food	HEAT SETTINGS
Melting butter/chocolate	1
Delicate sauces Finishing rice Simmering sauces with butter and egg yolk	1-3
Bacon Cooking vegetables, fish, broths Eggs, fried or scrambled Finishing cereals, pasta Milk Pancakes Pudding Simmering meats Steaming vegetables, fish, broths Pan frying Spaghetti sauces Sautéed vegetables Stewing meat, soups	4-6
Braising meat Pan frying meat, fish, Stir frying Quickly brown or sear meats Hold rapid boil	6-8
Boiling water for vegetables, pasta, rice, etc.	9

A range of heat settings are listed because the actual setting depends on:

- 1) type and quality of pan
- 2) type, quantity and temperature of the food
- 3) element used
- 4) the cook's preference.

208/240 Volt Connection: The Heat Settings recommended on this page are based on a 240 volt power source. If your cooktop is connected to 208 volts, the same heat settings apply but foods may take a little longer to finish cooking.

Cleaning Guide

Before Use Care

Care is easy when preventative steps are taken. For example, apply a small amount of Cooktop Cleaning Crème® (packaged with cooktop) on a daily basis.

This provides a protective film that makes it easy to remove water spots or food spatters. The temperature of the cooking surface reduces the protective qualities of this cleaner. **It must be reapplied** before each use.

Use a clean cloth and apply Cooktop Cleaning Crème® before each use to remove dust or metal marks that can occur on the counterlevel surface between uses.

CONTROL KNOBS

Pull up to remove. Slip a towel under the knob and hold edge of towel together. Using the towel for leverage, pull up. Wipe with hot, soapy cloth, rinse and dry. **Do not soak!**

SIDE TRIM

(Stainless steel models)

Always wipe with the grain when cleaning. For moderate/heavy soil, use BonAmi® or Soft Scrub® (no bleach). Wipe using a damp sponge or cloth, rinse and dry.

RECOMMENDED CLEANERS

- **Cooktop Cleaning Crème®**
Use only a small amount; apply to a clean paper towel or cloth. Wipe on the surface and buff with a clean dry towel.
- **BonAmi®**: rinse and dry.
- **Soft Scrub®** (without bleach): rinse and dry.
- **White Vinegar**: rinse and dry.
- **Razor blade scraper** (packaged with cooktop)
Note: The recommended cleaners indicate a type of cleaner and do not constitute an endorsement.

AVOID THESE CLEANERS

- **Glass cleaners which contain ammonia or chlorine bleach.** These ingredients may permanently etch or stain the cooktop.
- **Caustic Cleaners**
Oven cleaners such as Easy Off® may etch the cooktop surface.
- **Abrasive Cleaners**
Metal scouring pads and scrub sponges such as Scotch Brite® can scratch and / or leave metal marks.
Soap-filled scouring pads such as SOS® can scratch the surface.

Powdery cleaners containing chlorine bleach can permanently stain the cooktop.

Flammable cleaners such as lighter fluid or WD-40.

DAILY CLEANING TECHNIQUES

1. **Clean the surface when it is completely cool** with the following exception.

Remove these soils Dry Sugar, Sugar Syrup, Tomato Products, Milk immediately with the razor blade scraper:

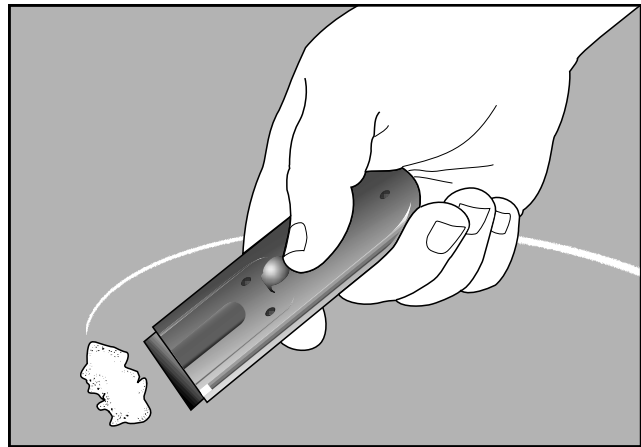

How to use a Razor Blade Scraper

CAUTION

Do not use any kind of cleaner on the glass while the surface is hot; use only the razor blade scraper. The resulting fumes can be hazardous to your health. Heating the cleaner can chemically attack and damage the surface.

2. **Wipe off spatters** with a clean, damp sponge or paper towel. Rinse and dry. Use white vinegar if smudge remains; rinse.

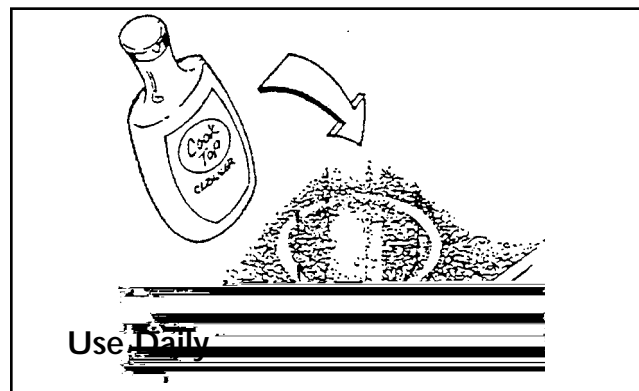

3. **Apply a small amount of the Cooktop Cleaning Crème®.** When dry, buff surface with a clean paper towel or cloth.

Special Care Chart

TYPE OF SOIL	POSSIBLE SOLUTION
<p>Dry sugar, sugar syrup, milk or tomato spills. Melted plastic film or foil. All these items REQUIRE IMMEDIATE REMOVAL.</p> <p>Remove only these types of spills while the surface is hot using the razor blade scraper. See illustration on Page 8.</p> <p>Be sure to use a new, sharp razor in your scraper.</p>	<p>Failure to remove these soils immediately can permanently damage the surface.</p> <ul style="list-style-type: none"> • Remove pan and turn off the element. • Wearing an oven mitt, hold scraper at 30° angle, using care not to gouge or scratch the glass. Push soil off the heated area. • After the surface has cooled, remove the residue and apply the Cooktop Cleaning Creme®.
<p>Burned-on food soil, dark streaks, and specks</p>	<ul style="list-style-type: none"> • Soften by laying a damp paper towel or sponge on top of soil for about 30 minutes. • Use a plastic scrubber and Cooktop Cleaning Creme® or use the razor blade scraper. Rinse and dry.
<p>Greasy spatters</p>	<ul style="list-style-type: none"> • Use a soapy sponge or cloth to remove grease; rinse thoroughly and dry. Apply Cooktop Cleaning Creme®.
<p>Metal marks: Iridescent stain</p>	<ul style="list-style-type: none"> • Pans with aluminum, copper or stainless steel bases may leave marks. Treat immediately, after surface has cooled, with the Cooktop Cleaning Creme. If this does not remove the metal marks, try a mild abrasive (Bon Ami®, Soft Scrub® without bleach) with a dampened paper towel; rinse; and reapply creme. <p>Failure to remove metal marks before the next heating makes removal very difficult.</p>
<p>Hard Water Spots Hot cooking liquids dripped on surface</p>	<ul style="list-style-type: none"> • The minerals in some water can be transferred onto the surface and cause stains. Use undiluted white vinegar, rinse and dry. Recondition with Cooktop Cleaning Creme. <p>Remove boilovers and stains, before using the cooktop again.</p>
<p>Surface scratches Small scratches are to be expected on the glass surface, but do not affect cooking. In time, small scratches will become smoother and much less noticeable with daily use of the Cooktop Cleaning Creme.</p>	<ul style="list-style-type: none"> • Apply Cleaning Creme before using to remove sand-like grains and grit such as salt and seasoning. • Can be reduced by using pans with bases that are smooth, clean, and dry before use. Use recommended Cooktop Cleaning Creme daily on the cooktop. <p>Be Careful: Diamond rings will scratch the surface.</p>

Troubleshooting

Before calling for service, check these suggestions to avoid unnecessary service charges.

QUESTION	SUGGESTED SOLUTIONS
Element cycles on the highest setting	<ul style="list-style-type: none"> • This is normal. The temperature limiter operates automatically to protect the glass ceramic surface from extreme high temperature damage.
Element cycles more than usual	<ul style="list-style-type: none"> • Pan base is warped and not making full contact with the heating surface. • Base diameter of pan is too small for the size of the element. • Pan ingredients have boiled dry. • Material of pan is a poor heat conductor; heat transfers too slowly
A slight odor is noticeable when an element is turned on	<ul style="list-style-type: none"> • This is normal with new cooktops and will disappear after several uses.
Cooktop controls will not turn on	<ul style="list-style-type: none"> • Check the power source to see if a fuse has blown or if the circuit breaker tripped. • Check power supply.
Replacement razor blades for the scraper	<ul style="list-style-type: none"> • The scraper is packaged with single-edge, stainless steel blades. Use a standard single-edge blade for replacement.
Cooking results are not what was expected	<ul style="list-style-type: none"> • The cooktop is not level. • Cooking pan does not fit the surface being used. • Cookware is not the type or size recommended.
Green tint on white glass	<ul style="list-style-type: none"> • Normal and will disappear as the surface cools down.

HOW TO OBTAIN SERVICE

Call: For authorized service or parts information, call 800/944-2904. We want you to remain a satisfied customer. If a problem does come up that cannot be resolved to your satisfaction please let us know.

Write: BSH Home Appliances Corp. Customer Support, 5551 McFadden Avenue, Huntington Beach, CA 92649 800/944-2904. Whether you write or call, please provide us with the model number, serial number and date of original purchase or installation.

Statement of Limited Warranty

The warranties provided by BSH Home Appliances Corp. in this Statement of Limited Warranty apply only to the BSH Electric Cooktops ("Cooktop") sold to you, the first using purchaser, provided that the Cooktop was purchased (1) for your use and not for resale and (2) in the United States or Canada and is located in the country of purchase. As used in this Statement of Limited Warranty, the term "Date of Installation" shall refer to the earlier of the date the Cooktop is installed or ten (10) business days after the date the Cooktop is sold to the first using purchaser, the warranties stated herein apply only to the first using purchaser and are not transferable.

Standard Limited Warranty

BSH warrants that its Cooktop is free from defects in materials and workmanship for a period of twelve (12) months from the Date of Installation. During the warranty period, BSH or its authorized service center will repair or replace, at its sole option, any Cooktop that proves to have been defective under conditions of normal use without charge. All removed parts and components shall become the property of BSH, at BSH's option. All replaced and/or repaired parts shall assume the identity of the original part for purposes of this warranty and this warranty shall not be extended with respect to such parts.

Extended Limited Warranty

BSH further warrants that the electric heating elements and controls of the Cooktop and the ceramic glass of the Cooktop shall be free from defects in materials for a period of time beginning on the twelfth (12th) month from the Date of Installation and continuing until the sixtieth (60th) month from the Date of Installation ("extended warranty period"). During the extended warranty period, BSH will replace any electric heating elements, controls, or ceramic glass of the Cooktop that proves to have been defective under normal conditions of use without charge, excluding any labor (including but not limited to labor charges incurred in the removal and reinstallation of any Cooktop), transportation, and/or shipping costs incurred in the performance of this extended warranty. All replaced parts covered under this paragraph shall assume the identity of the original for purposes of this extended warranty and this warranty shall not be extended with respect to such parts.

Other Conditions of the Limited Warranties

The warranties provided in this Statement of Limited Warranty exclude defects or damage resulting from (1) use of the Cooktop in other than its normal and customary manner (commercial use of the Cooktop shall not be deemed normal or customary), (2) misuse, abuse, accidents or neglect, (3) improper operation, maintenance, installation or unauthorized service, (4) adjustment or alteration or modification of any kind, (5) a failure to comply with applicable state, local, city, and county electrical and/or building codes, (6) spills of food or liquid, and (7) external forces such as floods, fires, acts of God or other circumstances beyond BSH's control. Also excluded from this warranty are scratches and damages on external surfaces and exposed parts of Cooktops on which the serial numbers have been altered, defaced or removed.

To the extent allowed by law, this warranty sets out your exclusive remedies with respect to products covered by it, whether the claim arises in contract or tort (including strict liability and negligence) or otherwise. BSH will not be liable for consequential or incidental damages, losses, or expenses. THIS WARRANTY IS IN LIEU OF ALL OTHER EXPRESS WARRANTIES. ANY WARRANTY IMPLIED BY LAW, WHETHER FOR MERCHANTABILITY OR FITNESS FOR A PARTICULAR PURPOSE OR OTHERWISE, SHALL BE EFFECTIVE ONLY FOR THE PERIOD THAT THIS EXPRESS WARRANTY IS EFFECTIVE. No attempt to alter, modify, or amend this warranty shall be effective unless authorized in writing by an officer of BSH.

How to Obtain Warranty Service

To obtain warranty service for the Cooktop, you should contact the nearest BSH authorized service center or the BSH Customer Support Call Center, 5551 McFadden Avenue, Huntington Beach, CA 92649, 800/944-2904.

NOTICE TO CALIFORNIA OWNERS

If your Cooktop needs warranty service and there is no authorized BSH service center reasonably close to you, you may notify the BSH reseller from whom you purchased the Cooktop. If the BSH reseller fails to repair or replace the defective parts, or partially refund your purchase price (where applicable), you may have the Cooktop repaired at any large appliance repair shop or center and you will be reimbursed for all reasonable expenses provided the costs are substantiated in writing and the work performed is covered by this warranty. BSH shall not reimburse any repair costs hereunder which exceed the depreciated value of the Cooktop.

Model Number _____
Serial Number _____

Specifications are for planning purposes only. Refer to installation instructions and consult your countertop supplier prior to making counter opening. Consult with a heating and ventilating engineer for your specific ventilation requirements. For the most detailed information, refer to installation instructions accompanying product or write to BSH Home Appliances Corp. indicating model number.

We reserve the right to change specifications or design without notice. Some models are certified for use in Canada. BSH is not responsible for products which are transported from the United States for use in Canada. Check with your local Canadian distributor or dealer.

For the most up to date critical installation dimensions by fax, use your fax handset and call 702/833-3600. Use code #8317.

BOSCH

5551 McFadden Avenue, Huntington Beach, CA 92649 • 800/944-2904
© 2002 BSH Home Appliances Corp. • Litho in USA • 02/02
50 60 00 34 92 (8201)