

*FourPointSurround™ FPS2000 Digital
Multimedia Speaker System
Installation and Operating Instructions*



Safety & Regulatory Information

The following sections contain notices for various countries:

Notice for the USA

FCC Part 15: This equipment has been tested and found to comply with the limits for a Class B digital device, pursuant to Part 15 of the FCC Rules. These limits are designed to provide reasonable protection against harmful interference in a residential installation. This equipment generates, uses, and can radiate radio frequency energy and, if not installed and used in accordance with the instructions, may cause harmful interference to radio communications. However, this notice is not a guarantee that interference will not occur in a particular installation. If this equipment does cause harmful interference to radio or television reception, which can be determined by turning the equipment off and on, the user is encouraged to try one or more of the following measures:

- Reorient or relocate the receiving antenna.
- Increase the distance between the equipment and receiver.
- Connect the equipment to an outlet on a circuit different from that to which the receiver is connected.
- Consult the dealer or an experienced radio/TV technician.

CAUTION: To comply with the limits for the Class B digital device, pursuant to Part 15 of the FCC Rules, this device must be installed with computer equipment certified to comply with the Class B limits.

All cables used to connect the computer and peripherals must be shielded and grounded. Operation with non-certified computers or non-shielded cables may result in interference to radio or television reception.

Modifications

Any changes or modifications not expressly approved by the grantee of this device could void the user's authority to operate the device.

Notice for Canada

This apparatus complies with the Class B limits for radio interference as specified in the Canadian Department of Communications Radio Interference Regulations.

Cet appareil est conforme aux normes de CLASSE "B" d'interférence radio tel que spe'cifie' par le Ministère Canadien des Communications dans les règlements d'interférence radio.

Declaration of Conformity

According to the FCC96 208 and ET95- 19

Manufacturer/
Importer's Name: **Creative Labs Inc.**
Manufacturer/
Importer's Address: **1901 McCarthy Boulevard
Milpitas, CA. 95035
United States
Tel: (408) 428-6600**

declares under its sole responsibility that the product

Trade Name: **Creative Labs/
Cambridge SoundWorks**

Model Number: **CSW1500**

has been tested according to the FCC / CISPR22/85 requirement for Class B devices and found compliant with the following standards:

EMI/ EMC: ANSI C63.4 1992, FCC Part 15 Subpart B

This device complies with part 15 of the FCC Rules. Operation is subject to the following two conditions:

1. This device may not cause harmful interference, and
2. This device must accept any interference received, including interference that may cause undesirable operation.

Ce matériel est conforme à la section 15 des règles FCC. Son fonctionnement est soumis aux deux conditions suivantes:

1. Le matériel ne peut être source d'interférences et
2. Doit accepter toutes les interférences reçues, Y compris celles pouvant provoquer un fonctionnement indésirable.

**Compliance Manager
Creative Labs, Inc.
January 18, 1999**

Compliance

This product conforms to the following Council Directive:

- Directive 89/ 336/ EEC, 92/ 31/ EEC (EMC), 73/23/EEC (LVD)

Modifications

Any changes or modifications not expressly approved by the grantee of this device could void the user's authority to operate the device.

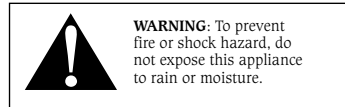

Important Notice

The serial number for the *FPS2000 Digital* is located on the subwoofer. Please write this number down and keep it in a secure area. This is for your security.



CAUTION!
Hot Surface

CAUTION:
This symbol indicates that the marked item may be hot and should not be touched without taking care.

- To minimize the risk of burns or other injuries to children, position the device such that hot surfaces are out of their reach.
- To minimize the risk of fire, keep flammable materials like paper and cloth (for example, curtains) away from the hot surfaces.

IMPORTANT SAFETY INSTRUCTIONS

READ INSTRUCTIONS - All safety and operating instructions should be read before the *FPS2000 Digital* amplified subwoofer/satellite system is operated.

RETAIN INSTRUCTIONS - The safety and operating instructions should be retained for future reference.

HEED WARNINGS - All warnings on the subwoofer and in the operating instructions should be adhered to.

FOLLOW INSTRUCTIONS - All operating and use instructions should be followed.

CLEANING - Unplug the Power Supply Adapter from the wall outlet or other power source before cleaning. Do not use liquid cleaners or aerosol cleaners. Use a damp cloth for cleaning.

ATTACHMENTS - Do not use attachments not recommended by Cambridge SoundWorks as they may cause hazards.

WATER AND MOISTURE - Do not use the subwoofer near water—for example, near a bath tub, wash bowl, kitchen sink, or laundry tub; in a wet basement; or near a swimming pool; and the like.

ACCESSORIES - Do not place the *FPS2000 Digital* system on an unstable cart, stand, tripod, bracket, or table. The subwoofer may fall, causing serious injury to a child or adult, and serious damage to the product. Any mounting of the satellites or subwoofer should follow the manufacturer's instructions, and should use a mounting accessory recommended by Cambridge SoundWorks.

VENTILATION - Slots and openings in the cabinet are provided for ventilation and to ensure reliable operation of the subwoofer and to prevent it from overheating. These openings must not be blocked or covered. The openings should never be blocked by placing the product on a bed, sofa, rug, or other similar surface. The openings should not be placed in a built-in installation such as a bookcase or rack unless proper ventilation is provided or Cambridge SoundWorks' instructions have been adhered to.

HEAT - The subwoofer should be situated away from heat sources such as radiators, heat registers, stoves, and other products (including amplifiers) that produce heat.

POWER SOURCES - The subwoofer should be operated only from the type of power source indicated on the marking label. If you are not sure of the type of power supply to your home, consult your product dealer or local power company. For products intended to operate from battery power, or other sources, refer to the operating instructions.

POLARIZATION - The power supply may be equipped with a polarized alternating-current line plug (a plug having one blade wider than the other). This plug will fit into the power outlet only one way. This is a safety feature. If you are unable to insert the plug fully into the outlet, try reversing the plug. If the plug should still fail to fit,

contact your electrician to replace your obsolete outlet. Do not defeat the safety purpose of the polarized plug.

POWER-CORD PROTECTION - Power supply cords should be routed so that they are not likely to be walked on or pinched by items placed upon or against them, paying particular attention to cords at plugs, convenience receptacles, and the point where they exit from the subwoofer.

LIGHTNING - For added protection for the *FPS2000 Digital* system during a lightning storm, or when it is left unattended and unused for long periods of time, unplug it from the wall outlet. This will prevent damage to the subwoofer due to lightning and power-line surges.

OVERLOADING - Do not overload wall outlets, extension cords, or integral convenience receptacles as this can result in a risk of fire or electric shock.

OBJECT AND LIQUID ENTRY - Never push objects of any kind into the subwoofer through openings as they may touch dangerous voltage points or short out parts that could result in a fire or electric shock. Never spill liquid of any kind on the speakers or the subwoofer.

SERVICING - Do not attempt to service any part of the *FPS2000 Digital* yourself as opening or removing covers may expose you to dangerous voltage or other hazards. Refer all servicing to qualified service personnel.

DAMAGE REQUIRING SERVICE - Unplug the power supply from the wall outlet or other power source and refer servicing to qualified service personnel under the following conditions:

- When the power supply adapter or plug is damaged.
- If liquid has been spilled, or objects have fallen into the subwoofer.
- If the subwoofer or power supply adapter has been exposed to rain or water.
- If the *FPS2000 Digital* does not operate normally by following the operating instructions; or exhibits a distinct change in performance.
- If the product has been dropped or damaged in any way.

REPLACEMENT PARTS - When replacement parts are required, be sure the service technician has used replacement parts specified by Cambridge SoundWorks or have the same characteristics as the original parts. Unauthorized substitutions may result in fire, electric shock, or other hazards.

SAFETY CHECK - Upon completion of any service or repairs to the *FPS2000 Digital* system, ask the service technician to perform safety checks to determine that the *FPS2000 Digital* system is in proper operating condition.

WALL OR CEILING MOUNTING - The *FPS2000 Digital* satellites should be mounted to a wall or ceiling only as recommended by Cambridge SoundWorks.

*FourPointSurround
FPS2000 Digital
Multimedia Speaker System*

Contents

Introduction 1
Inspecting For Damage 2
Overview 2
Installation Sequence 2
Speaker Placement 3
Speaker Wiring Diagram 4
Satellite Connections 5
Attaching The Floor Stands 6
Power Supply Adapter 7
Audio Signal Connections 7
Connection To Sound Blaster Live! Via DIGITAL DIN 8
Volume Control 8
Using The Volume Control 9
Mounting The Volume Control 9
Adjusting Output Level 10
Bass Level Control 10
Optimizing The Sound Of Your System 11
Mounting The Satellites 11
Important 12
Specifications 12
Technical Support 12
1-Year Limited Warranty 13

Introduction



Thank you for purchasing
FourPointSurround
FPS2000 Digital
by Cambridge SoundWorks.

The *FPS2000 Digital* is the first multimedia speaker system to support DirectSound®3D and Environmental Audio in true multichannel, digitally transferred sound. It lets you experience the full potential of the multichannel sound encoded in today's latest computer software. We think you will find it adds an exciting new dimension to computer sound and gaming.

Cambridge SoundWorks

1-877-YES-HIFI

(1-877-937-4434),

8 AM to Midnight,

Eastern time

1 PM to 4 AM

Greenwich Mean Time

Outside US:

Tel: 617-332-5936

Fax: 617-527-3194

www.cambridgesoundworks.com

or e-mail us at

info@cambridgesoundworks.com

Inspecting For Damage

Examine each speaker unit carefully for signs of shipping damage. If there is any damage, do not install the system.

If there is any problem, or if anything is missing, call the store where the system was purchased or refer to the "Technical Support" section on pages 12-13.

Save the carton and its inserts in case you need to transport your *FPS2000 Digital* system later.

Overview

The four small satellite speakers of the *FPS2000 Digital* are magnetically shielded. They can be placed next to a computer monitor. The subwoofer/amplifier is not shielded and should be placed at least 18 inches away from a computer monitor.

The subwoofer is designed to sit on the floor beneath a desk, and sounds best in this position. The satellites used for the front left and right channels should flank the computer monitor. The satellites used for the rear left and right channels can be placed on the desktop, on floor stands, or attached to other sites (using screws).

Installation Sequence

1. Read through the instructions before installing the speakers. The instructions assume you have a 4-channel sound card—one that supports DirectSound®3D and has separate front and rear stereo minijack outputs. If your sound card has a single stereo minijack line output, please read the note under "Audio Signal Connections" on page 7.
2. Place the satellites and the subwoofer at appropriate sites near your computer. Attach the stands, if necessary.
3. To help you identify each satellite's channel, apply the appropriate preprinted label to the rear of each satellite.
4. Connect the four satellites to the back of the subwoofer enclosure. Leave all the wires accessible.
5. Connect your sound card outputs to the subwoofer.



(1) Subwoofer/amplifier

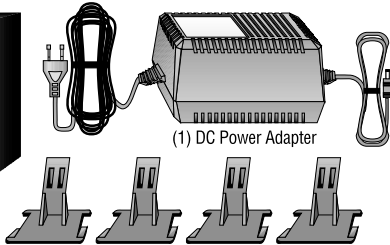

(1) DC Power Adapter
(4) DeskTop Stands for satellites

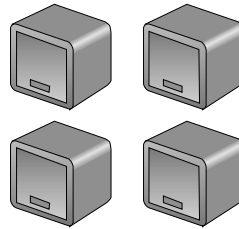

(4) Satellite Speakers



(4) Wall mounting hardware



(1) SPDIF Cable



(1) Audio Connection Cable



(1) Volume Control with 12 ft. audio connecting cable



(2) 3 meter (10 feet) wire lengths



(2) 5 meter (16 feet) wire lengths



Semipermanent mounting strip
(1) for attaching volume control



(6) Rubber foot plugs



(4) Solid Legs



(2) Apex Joints



(2) Slotted Legs



(4) Strips of 4 feet

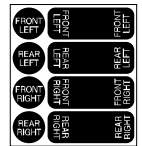

(1) Labels

Speaker Placement

6. Connect the Volume Control to the subwoofer.
7. Connect the power supply adapter.
8. Listen to the system and adjust the Bass Level control for pleasing bass output.
9. You may wish to experiment with satellite placement briefly before concealing the connecting wires and making the installation more permanent.

The Front Satellites

The front left and right satellites should be placed to the sides of the monitor. Install the desktop stands if placing the satellites on the desktop.

The Rear Satellites

If you are lucky enough to have side walls close to your listening position, excellent placement for the rear left and right satellites is behind your listening position, slightly above ear level (use a screw to hang each satellite, see diagram **A**). Do not be concerned if this is not practical, since any rear satellite

placement behind or to the side of the listening position will provide strong directional and surround effects.

The rear satellites may be installed on their convenient floor stands. The stands should be positioned behind your listening position and aimed at the listener. The stands are small enough to be stowed underneath or alongside a desk when not in use (see diagram **B**).

If none of these locations are practical, the rear satellites may be placed in convenient sites alongside the listener, including sites slightly forward of the listening location.

The rear satellites do not have to be at the same height, or at the same height as the front satellites. Try the extreme corners of a desk using the desktop stands (**C**) or attach the rear satellites under a desktop or at the sides of a desk using the hook & loop fasteners (**D**).

The Subwoofer

The subwoofer's optimum position is on the floor against the wall. The closer the subwoofer is to a corner, the stronger the maximum bass output. Position the subwoofer so that its connection panel is facing a wall, shielded from inadvertent contact.

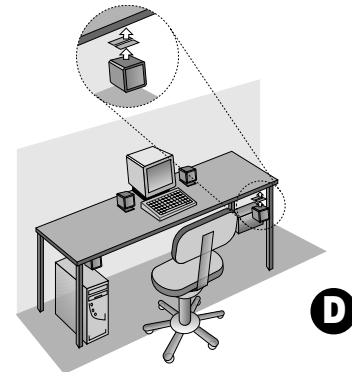
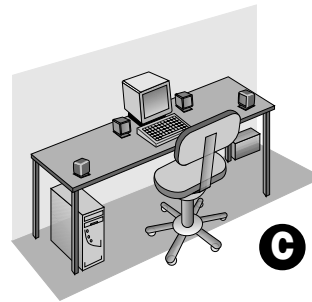
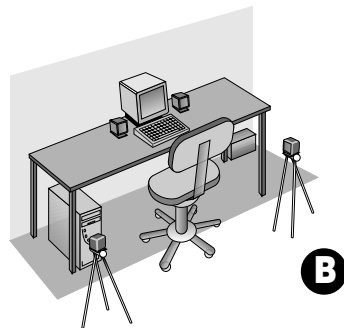
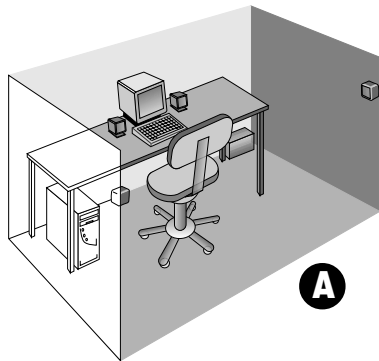

Speaker Wiring Diagram

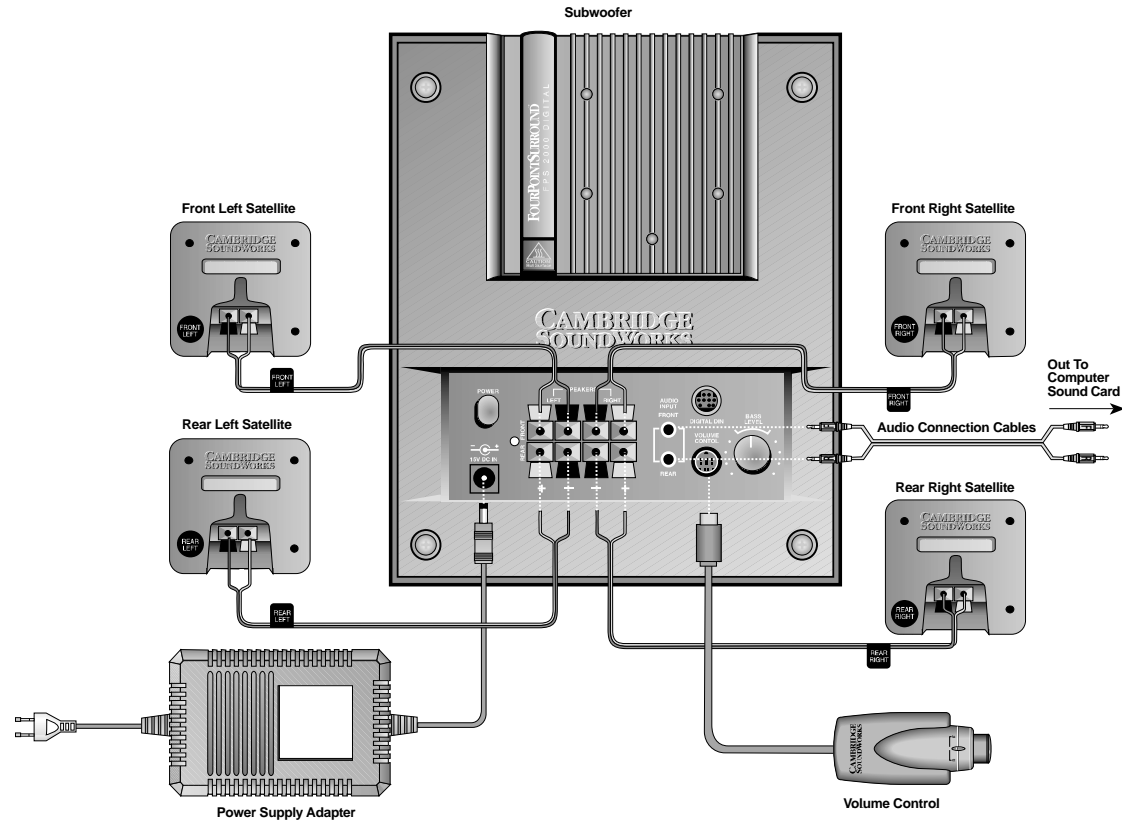

Satellite Connections

Typically, the 3 meter speaker cables will connect the front satellites to the subwoofer and the 5 meter cables will connect the rear satellites to the subwoofer.

A panel of eight self-adhesive labels is provided to identify each satellite and the opposite end of the cable connected to a satellite.

1. Identify the two 3 meter cables. Most satellites will be used with their desktop stands. In this case, thread one end of a 3 meter cable through the hole in the desktop stand. Connect this end to one satellite, (as shown in diagram E). If used, carefully insert the desktop stand's attachment arm into the socket in the back of the satellite, taking up any slack in the cable as required.
2. Remove the backing from the small, round "FRONT LEFT" label and apply it to the back of the satellite (see diagram E).
3. Remove the backing from the remaining, longer "FRONT LEFT" label and wrap it around the opposite end of the speaker cable you just connected.

4. Connect this end of the speaker cable to the red and black "FRONT LEFT" speaker connectors on the subwoofer.
5. Repeat this process for the Front Right, Rear Right and Rear Left satellites. *Be sure to use the remaining 3 meter cable for the other front speaker.*

Diagram E

To connect the speaker wires to the satellite and subwoofer, push back on a spring-loaded tab to expose the connection hole. Insert the bare end of the wire into the exposed hole, then release the tab to lock the wire in place.

Connect wires with red bands to red tab connectors and unmarked wires to black tab connectors.

Notes: Matching red wires to red tabs and unmarked wires to black tabs insures the speakers all play "in-phase". "Out of phase" connections will do no electrical harm, but the positional audio sound quality will be greatly reduced. You can substitute regular 18 gauge speaker wire to create longer cables, if needed.

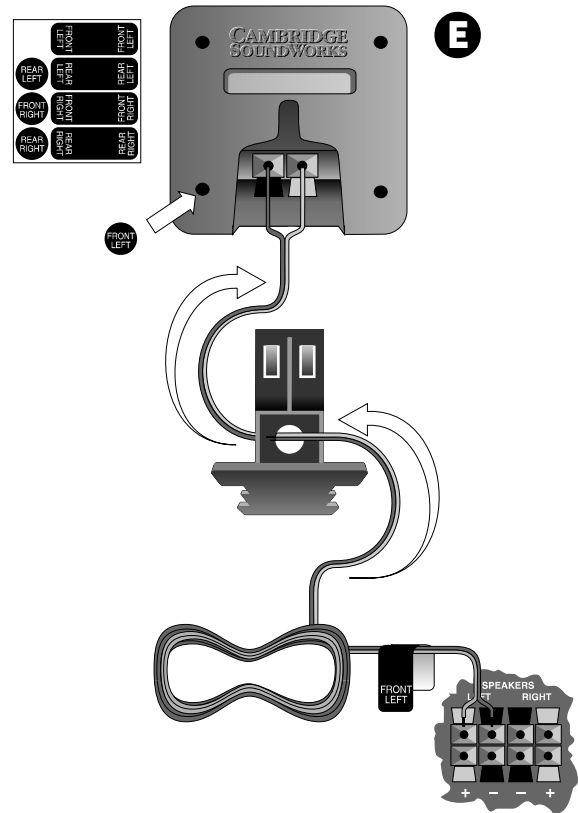

Attaching The Floor Stands

The rear satellites (with their desktop stands attached) may be installed in their floor stands.

1. One leg of each floor stand has a full length slot, with short notches opposite the slot at each end. Insert a satellite cable inside one of these legs

by feeding it down the length of the full length slot. At each end, feed the cable through the short notches (see diagram G).
2. Insert the satellite end of the leg/cable assembly into the middle socket of the apex joint. Make sure the satellite cable exits through the short notch and not the full length slot (see diagram F).

3. Insert the two solid legs into the outside sockets in the apex joint.
4. Position the two "cut-away" sections of the desktop stand over the opening in the top of the apex joint, as shown in diagram F. Be sure to align the face of the stand with the face of the apex joint. Lower the stand straight down into the apex joint.

5. Holding the ends of the apex joint, push on the front of the desktop stand until it slips back into the slot in the apex joint. Confirm a secure fit.
6. At the base of the rear leg, gently pull on the satellite cable to remove any unnecessary slack in the cable.
7. Insert a rubber plug into the base of each leg, taking care to feed the cable out the short notch in the rear leg (see diagram H).

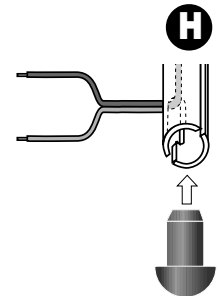
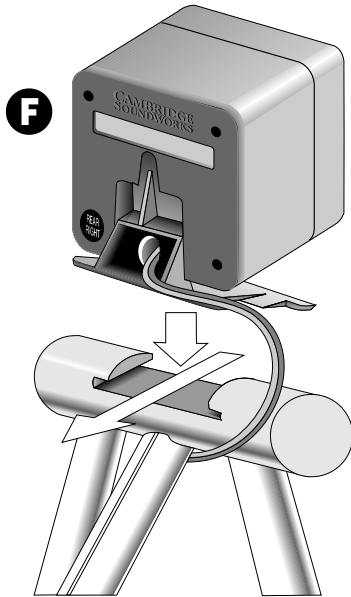

Power Supply Adapter

Confirm that the power switch is in the "OFF" position. Insert the power supply's AC plug into the appropriate receptacle. Insert the small DC connector into the "15V DC IN" receptacle on the back of the subwoofer (see diagram I).

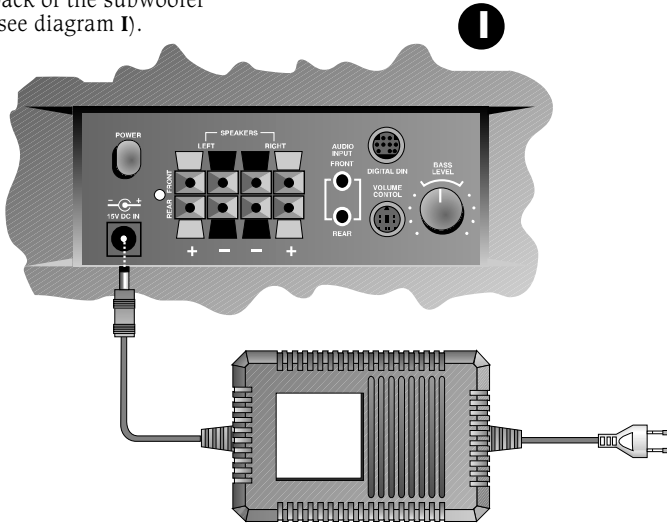

Audio Signal Connections

The *FPS2000 Digital* comes with a front/rear audio signal cable. Connect this cable between your sound card and the subwoofer (see diagram J).

1. Insert one of the green miniplugs into the green minijack (**LINE OUT**) on your sound card.
2. Insert the corresponding black miniplug into the black minijack (**REAR OUT**) on your sound card.
3. Insert the green miniplug at the other end of the cable into the green minijack (**FRONT**) on the subwoofer.
4. Insert the black miniplug into the black minijack (**REAR**) on the subwoofer.

Note: If you have a stereo sound card (one without a rear stereo minijack line output), connect a green miniplug cable to the **LINE OUT** minijack of your sound card and the opposite green miniplug to the **FRONT** minijack on the subwoofer. This will cause both left front and left rear satellites to play the left stereo channel and both right satellites to play the right stereo channel.

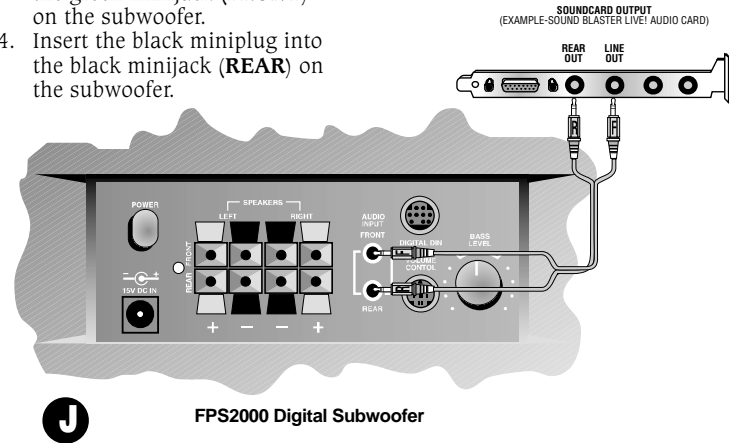

Connection To Sound Blaster Live! Via DIGITAL DIN

If your *Sound Blaster Live!* sound card includes a Digital I/O card, you can take advantage of the clear, distortion-free audio available from its Digital DIN output.

1. Insert one end of the SPDIF cable into the DIGITAL DIN output jack on the *Sound Blaster Live!* Digital I/O card. The position of the Digital DIN connector on the Digital I/O card may be different from this diagram. The Digital DIN connector is the only connector with a 9-pin configuration.



Digital DIN Connector

2. Insert the other end of the SPDIF cable into the DIGITAL DIN input on the subwoofer (see diagram K).
3. Use the following procedure to configure the *Sound Blaster Live!* sound card for four speakers:
 - Bring your mouse pointer to the top of the monitor screen to display the Creative Launcher.
 - Click on AudioHQ.
 - Click on the Speaker tab. The speaker dialog box will appear.

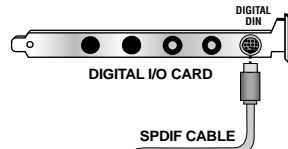

DIGITAL I/O CARD

SPDIF CABLE

K

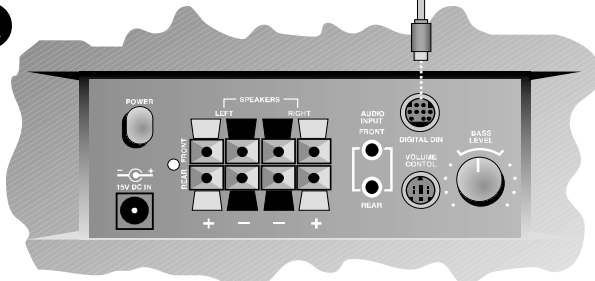

FPS2000 Digital Subwoofer

Volume Control

The *FPS2000 Digital* system comes with a separate wired Volume Control, designed to be positioned close at hand and affixed with the semipermanent mounting strip.

Connect the circular plug at the end of the Volume Control into the circular Volume Control jack on the back of the subwoofer (see diagram L).

- On the Configuration tabbed page, select the "4 Speakers" option.
- A sofa icon (representing you) appears in the center of the Preview box, with four speakers at the corners of the box.

Note: The *FPS2000 Digital* will detect the presence of a plug connected to the DIGITAL DIN input and give the DIGITAL DIN input priority. Any signal present at the AUDIO input will be ignored. Be sure to remove the plug from the DIGITAL DIN input if you wish to listen to a sound source through the analog AUDIO INPUT.

L

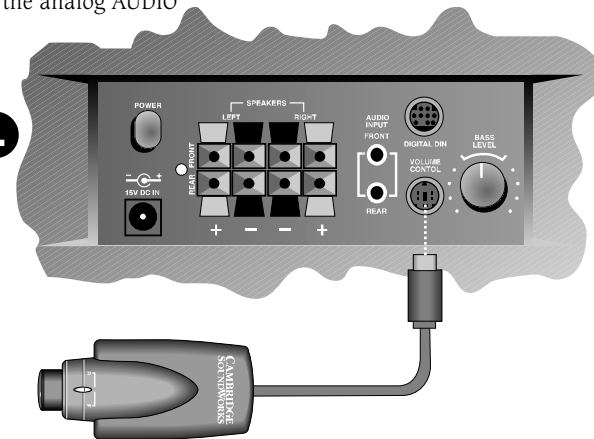

Using The Volume Control

The Volume Control has a Front/Rear Balance Control, a Master Level Control (see diagram **M**), and an On/Off power switch.

Use the Master Level Control whenever you wish to adjust the speaker output level.

Adjust the Front/Rear Balance Control to achieve satisfactory output from all four speakers. It should not be necessary to adjust the control more than once while playing any single game. Different games may benefit from different Front/Rear Balance Control settings.

Software for Creative Labs sound cards allows you to adjust the rear speaker output level. The rear speaker level adjustment is found within the "Creative Configurator" in *Sound Blaster PCI64/128* software. Set this

adjustment to its highest setting. *Sound Blaster Live!* and *Sound Blaster Live! Value* software has rear speaker level adjustment within the mixer application. Set the "FRONT/REAR BALANCE" slider to its mid-way position.

Other sound card software may have similar front to rear balance adjustments. Be sure these controls are set for sufficient output in all four channels, then use the Front/Rear Balance Control from that point forward.

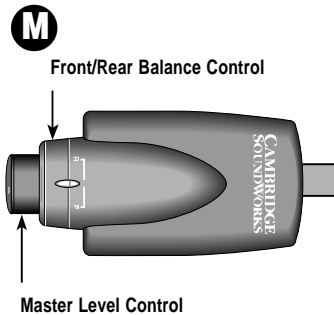

Mounting The Volume Control

The enclosed mounting strip is semipermanent—it holds well but can be peeled off gently. Be sure that the mounting surface, such as the computer monitor or your desktop, is smooth and clean.

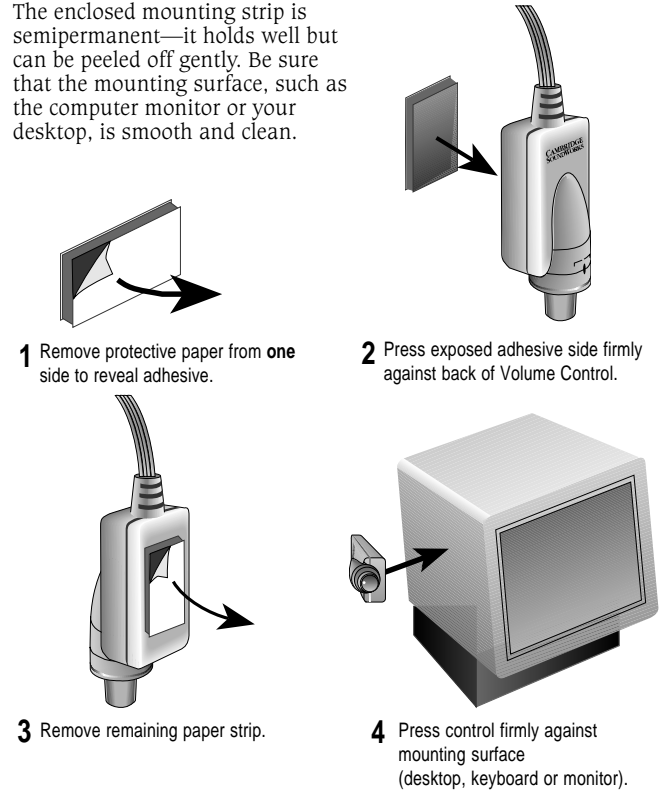

Adjusting Output Level

In most instances, the *FPS2000 Digital* Master Level Control will be the most convenient way to adjust the overall playback level. It responds instantly and doesn't require you to pause games or programs. But there are other output level controls present in software to consider.

Versions of Microsoft® Windows® and most other operating systems offer an on-screen sound level Control, while most game programs provide yet another one. For the *FPS2000 Digital* Master Level Control to perform at its best, these "software" level controls should be set to an "optimum" position and then left alone.

Set any software volume controls to approximately 75% of their maximum output level. This should allow the *FPS2000 Digital* Master Level Control to achieve the highest output level desired when set to its loudest setting.

If the *FPS2000 Digital*'s maximum output is still not sufficient at the extreme setting of its Volume Control, try increasing one, and only one, of the software volume controls to increase overall output.

If you find the optimum output level of the *FPS2000 Digital* system occurs at too low a setting of its Volume Control, reduce the setting of one software volume control (preferably the operating system's output level control) to achieve greater control range.

Note: Some software volume controls may introduce distortion when set to their maximum level. Experiment to achieve the cleanest sound.

Bass Level Control

The output of the subwoofer can be adjusted to suit the listener's taste. Start with the control in the 12 o'clock position (see diagram **N**). After using the system for a couple of hours, adjust the control up or down to fine-tune it.

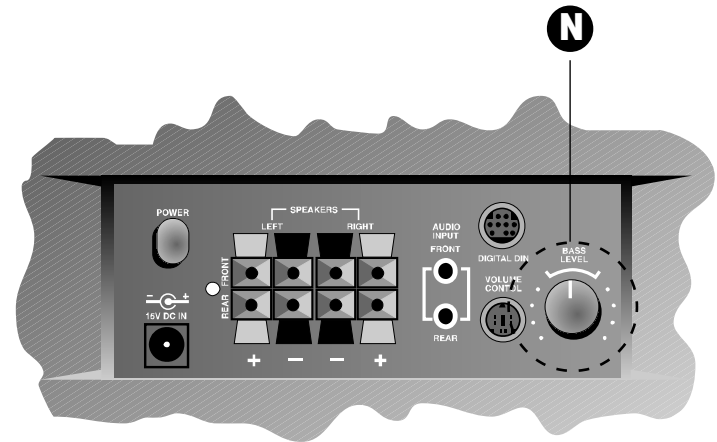

Optimizing The Sound Of Your System

Have a clear line of sight from your listening position to the satellites. This prevents their higher frequencies from being blocked. It is not necessary for each satellite to be aimed directly at the listener.

The relative strength of low-bass depends on how close the subwoofer is to intersecting room surfaces. The

most bass output results from the subwoofer being placed on the floor in a corner. The least bass output results with the unit positioned away from any corners or walls.

Once you have adjusted the Bass Level Control, leave it in that position. It should not be used to compensate for differences in recordings or games.

Mounting The Satellites

To the wall:

To wall-mount the cubes on structurally strong surfaces (a wall stud or wood panelling), screw a M5 x 25mm screw into the material. Allow their heads to protrude about 1/4 inch to fit into the keyhole slots on the back of each cube (see diagram **O**).

The plastic anchors supplied will be needed to secure the screws in most wall surfaces. If so, drill 1/4 inch holes in the wall, then tap the anchors into the holes until they are flush with the wall. Then screw the screws into the anchors until they protrude about 1/4 inch.

Be sure to apply the stick-on rubber feet to the back of the satellite cubes. This assures an acoustically secure installation.

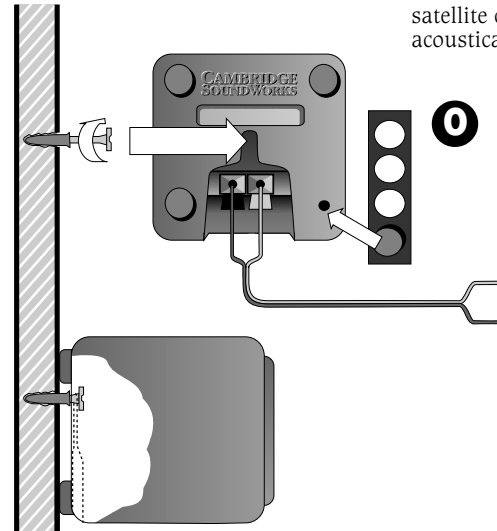

Keyhole slot mounting



Important

Playback Levels

FPS2000 Digital is intended for individual or small group listening and will achieve surprisingly high output levels. However, playing the system continuously at overly loud, distorted levels on heavy bass program material may cause its internal fuse to blow.

The fuse can be replaced *only* by a qualified service representative. To avoid this inconvenience and a possible non-warranty repair charge, reduce the playback volume when the system shows obvious signs of stress, i.e. it sounds “raspy,” “fuzzy,” and/or “muddy.”

Specifications

FPS2000 Digital's
**Four-channel
Amplifier Specifications**

Subwoofer: 25 watts RMS.

Satellite: 7 watts RMS per channel.

These specifications apply to a *FPS2000 Digital* operating from a 15V DC power adapter.

Technical Support

Inside U.S.A., Canada and Latin America

Creative Labs Inc. Technical Support

If you need technical assistance, call **405-742-6622**. Technical support is available seven days a week from 8:00 am to midnight, Central time.

You can get the latest program and driver updates from Creative Labs' bulletin board, 24 hours a day. Call **405-742-6660**; use modem settings:

Baud rate: **300 to 14400**
 (V.32/V.42 bis)
Data bits: **8**
Parity: **none**
Stop bits: **1**

You can also send a FAX at **405-742-6633** or write us at:

Technical Support
Creative Labs, Inc.
1523 Cimarron Plaza
Stillwater, OK 74075

To reach Creative Technical support via the Internet, visit our technical support web site at **<http://www.creativehelp.com>**, for troubleshooting help.

For information about this product and other Creative Labs products, visit Creative Zone at **<http://www.soundblaster.com>**. Or, call Customer Service at **800-998-1000**

Faxback information is available by calling **405-372-5227**

1-Year Limited Warranty

Inside Asia

Creative Technology Ltd. Technical Support

**31 International Business Park,
Creative Resource, Singapore 609921**

Tel: +65 8954100
Fax: +65 5696640

Operating hours (Singapore Time)

Mon-Fri: 9am-6pm
Sat-Sun & Public Holidays: Closed

To the original purchaser, Cambridge SoundWorks, Inc. will warrant the *FPS2000 Digital* system to be free of defects in material and workmanship for a period of one (1) year from date of purchase. With respect to defects, Cambridge SoundWorks will, at its option, replace the product or repair the defect in the product with no charge to the original purchaser for parts or labor.

This warranty does not extend to any defect, malfunction or failure caused by misuse, abuse, accident, faulty hook-up, defective associated equipment or use of the speaker with equipment for which it is not intended.

This warranty is valid only when the speaker is returned to the retailer that sold the *FPS2000 Digital* to the original purchaser.

This is the sole and expressed warranty. This warranty is in lieu of all other warranties, expressed or implied, of merchantability, fitness for purpose or otherwise. In no event shall Cambridge SoundWorks, Inc. be liable for incidental or consequential damages or have any liability with respect to defects other than the obligations set forth as stated.

To ensure warranty coverage, it is incumbent upon the original purchaser of *FPS2000 Digital* to inform the retailer of the defect within the warranty period. The only acceptable method of establishing warranty status is a copy of the original proof of purchase indicating customer's name and purchase date.

For advice about your warranty or any information, call the store where purchased or refer to the "Technical Support" section on pages 12-13.

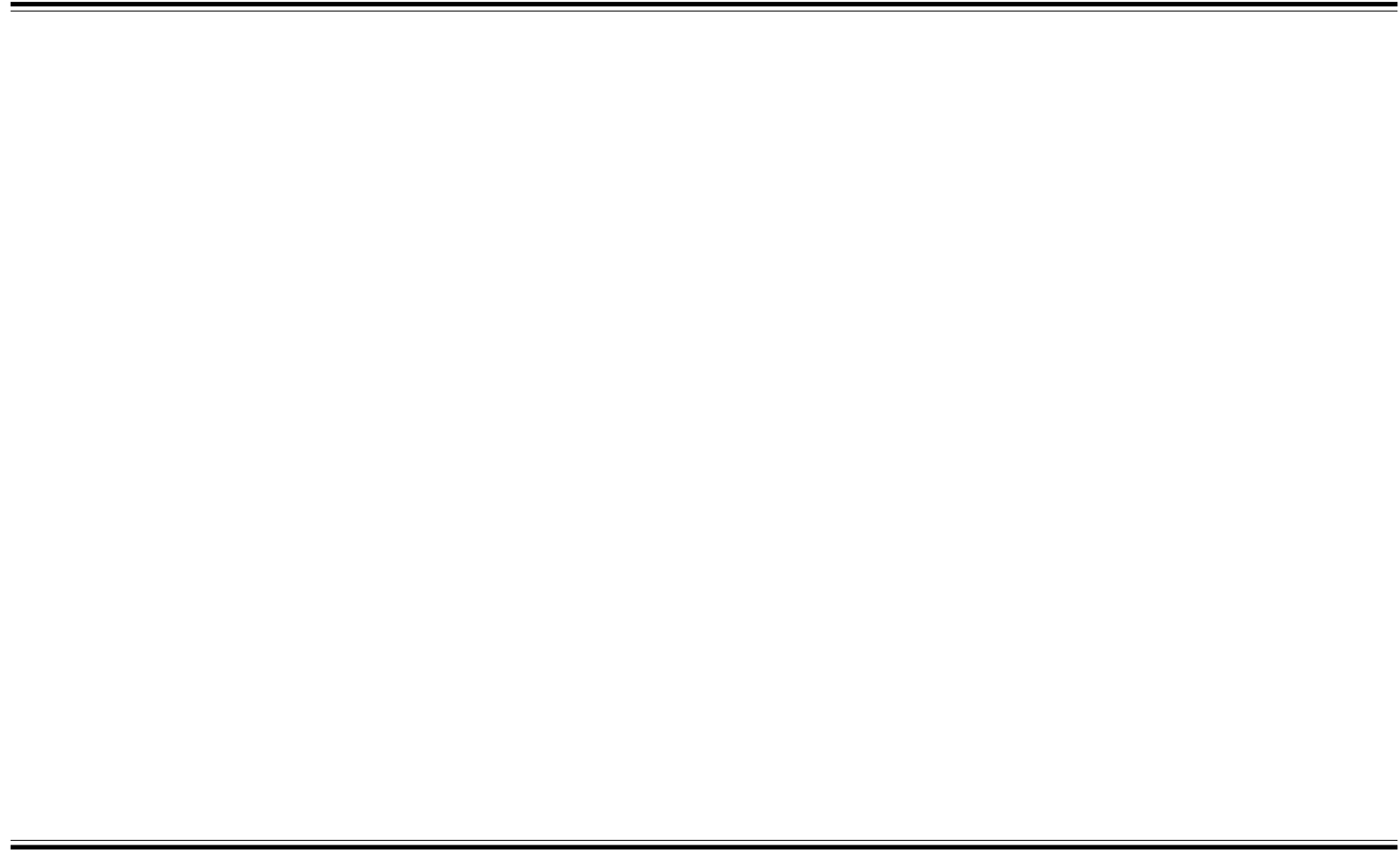



C A M B R I D G E[®]
SOUNDWORKS

311 Needham Street, Newton, MA 02464
1-877-937-4434 Fax: 617-527-3194
www.cambridgesoundworks.com
or e-mail us at info@cambridgesoundworks.com

0420003004 Rev. C