

JVC[®]

The Perfect Experience / —

DLA-F110
D-ILA Projector

An all-new 3D D-ILA projector for professional use
that provides unparalleled picture quality.



*Optional 3D Glasses (PK-AG1) and 3D Synchro Emitter (PK-EM1) are required for viewing images in 3D.

Professional 3D D-ILA projector from JVC delivers remarkable image reproduction and answers any installation requirement.

Ideal for a variety of applications, the DLA-F110 is an all-new professional 3D projector that ensures remarkably bright and high-resolution image reproduction, which is made possible with JVC's exclusive D-ILA technology.



Museum/Gallery

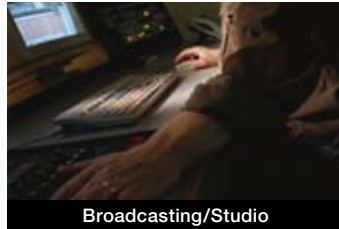

Broadcasting/Studio



Academic/Multi-purpose Hall



Aquarium/Museum



Planetarium



Medical



Design/R&D/Virtual Reality

Dynamic high-quality images

Native contrast of 30,000:1

A native contrast ratio of 30,000:1 is realised by incorporating JVC's original D-ILA device with a new optical engine. Thanks to truer black levels, darker images such as the night sky can be more precisely reproduced to make the DLA-F110 suitable for displaying content with considerable depth such as that shown at museums, laboratories, planetariums, etc.



Conventional projector



DLA-F110

Equipped with JVC's originally developed D-ILA device

The projector is equipped with a 0.7-inch full HD D-ILA device (1920 x 1080 dot) that is originally developed by JVC. Combined with the high aperture ratio of the D-ILA method*, this full HD resolution device ensures smooth video reproduction without the "screen-door" effect even for large screen sizes. This means that text and numerals in subtitles or on the screen are reproduced clearly without any bleed. What's more, the D-ILA device is also known for its long operating life and consistent performance.

*D-ILA is a device originally developed by JVC and is also known as the LCOS (liquid crystal on silicon).



D-ILA device

Comparison of small text and numerals

Gumma	994,315	1,017,836	2,012,151
Saitama	3,563,014	3,504,322	7,067,336
Chiba	3,056,110	3,034,689	6,090,799
Tokyo	6,189,004	6,273,192	12,462,196
Kanagawa	4,441,495	4,356,794	8,798,289
Niigata	1,170,645	1,242,458	2,413,103
Toyama	534,180	572,160	1,106,340

D-ILA method



Simulated pictures

Gumma	994,315	1,017,836	2,012,151
Saitama	3,563,014	3,504,322	7,067,336
Chiba	3,056,110	3,034,689	6,090,799
Tokyo	6,189,004	6,273,192	12,462,196
Kanagawa	4,441,495	4,356,794	8,798,289
Niigata	1,170,645	1,242,458	2,413,103
Toyama	534,180	572,160	1,106,340

Conventional method

1,700-lumen brightness

The optical engine utilises a newly developed 220W ultra-high pressure mercury lamp to achieve a brightness level of 1,700 lumens. And this is complemented by a high-performance 2X motorized zoom lens that realises vivid color reproduction while maintaining excellent brightness and outstanding focusing precision. When combined with the high 30,000:1 native contrast ratio, the lens system is capable of reproducing video content with the kind of brilliant colors that only the D-ILA method can provide. What's more, a 16-step lens aperture function enables brightness adjustment to not only suit user preferences but also operating ambiances, helping to ensure deeper and truer black levels.



Conventional projector



DLA-F110

New Color Management System with 7-axis matrix

In addition to the ordinary 6-axis matrix of red, green, blue, cyan, magenta, and yellow, the new Color Management System features a seventh matrix of orange to ensure the precise adjustment of hue, saturation, and intensity. The addition of the orange axis also helps in enhancing the selection of the color spectrum for skin tones. And for improved operability, only the color being adjusted will be shown on the screen while the others are displayed in black and white.



Displays only the color being adjusted; others are displayed in black and white.



■ D-ILA projection in 3D

The DLA-F110 employs a Frame Sequential 3D method to display left and right images simultaneously, which when viewed with a pair of 3D Active Shutter glasses that darken alternately for each eye, enables 3D images to be viewed. Additionally, the fast response characteristics and picture quality offered by D-ILA technology allow viewers to enjoy vivid and colorful 3D images with far less crosstalk or image ghosting. This means that a special screen is not necessary, making the DLA-F110 ideal for various applications that utilise 3D video content such as amusement centers, museums, and laboratories. This D-ILA projector is also compatible with a number of 3D formats including Frame Packing for Blu-ray 3D, Side-by-Side (used mainly for broadcasting), and Top-and-Bottom.

Note: Keystone, anamorphic mode, and certain other functions cannot be used while projecting in 3D mode.

■ Optional Equipment



3D Glasses
PK-AG1-B



3D Synchro Emitter
PK-EM1

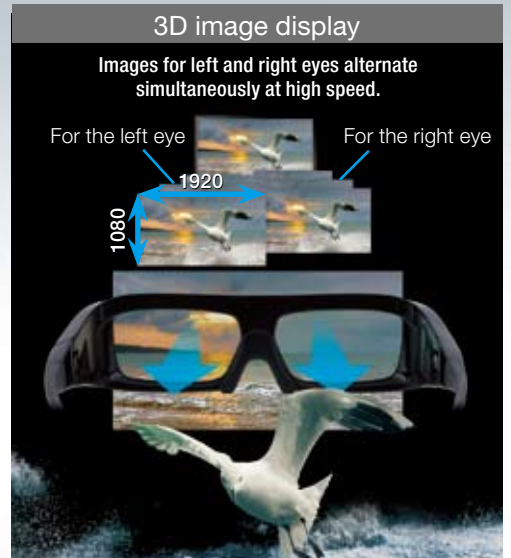

Notes about viewing 3D video content

- The optional 3D Synchro Emitter and 3D glasses are required to view 3D images from the DLA-F110. 3D video software and a 3D-compatible video player are also required.
- Perception of 3D images will vary with individual viewers.
- Stop viewing 3D images immediately if any discomfort such as headaches, dizziness, eye strain, or nausea occurs.
- Viewing of 3D images by children under the age of five is not recommended.
- Read the Safety Precautions in the User Manual carefully before viewing any 3D source.

Flexible installation and easy maintenance

■ Powered lens shift and 2X zoom lens

As standard equipment, the DLA-F110 features a 2X motorised zoom lens with motorized focus that can project images onto a large 100-inch screen at distances of between 3.1 and 6.2 metres. Additionally, flexible installation in a variety of setup environments is assured thanks to the powered lens-shift function, which enables $\pm 80\%$ vertical and $\pm 34\%$ horizontal adjustment via remote control.

NOTE: Shift range values are used to set vertical and horizontal shifts individually. The maximum shift value will differ when vertical and horizontal lens shift are adjusted together.

◆ Horizontal position

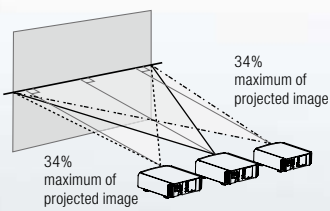

◆ Vertical position

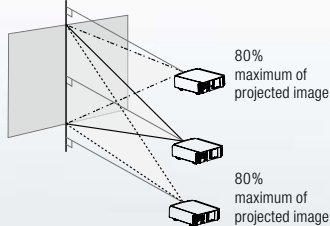

■ Tilted installation 360° vertically

The DLA-F110 projector can be installed vertically at any angle, making it suitable for use in confined spaces or otherwise difficult installation applications.

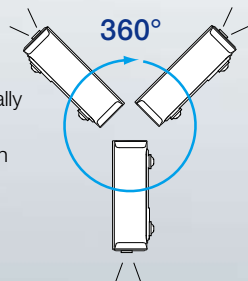

■ Easy-to-use remote controller

The projector comes supplied with a wireless remote controller offering various direct operations such as video input. The buttons on the controller are designed to illuminate automatically to ensure easy operation even in the dark and an optional wired remote controller that is capable of controlling the projector from out-of-reach locations is also available*.

*Availability may vary; consult a local authorised JVC dealer for details.

■ Lamp replacement after 3,000 hours (Normal mode)

A highly efficient 220W ultra-high pressure mercury lamp is used to realise extended operation of up to 3,000 hours in Normal mode to help reduce maintenance costs.



■ Keystone function*

Distorted images that are caused by vertical tilt on the projector can be adjusted via the Keystone function. When the projector is positioned outside of its lens shift coverage area, the Keystone function digitally adjusts distorted images to make them look more natural.

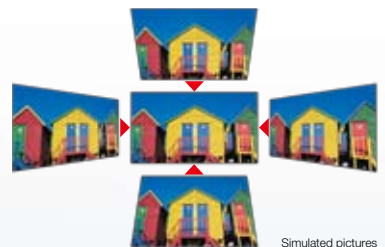

*Cannot be used while projecting in 3D mode.

■ A wide range of input and output terminals

In addition to two HDMI terminals, the DLA-F110 is equipped with two analog RGB inputs and is also compatible with PC analog signals. Other terminals making the projector seamless with various systems and applications include RC-232C, a LAN terminal for projector control, remote terminals for remote operation via connection of an extended IR sensor, and a trigger terminal, making the DLA-F110 applicable for a wide variety of systems.



DLA-F110

D-ILA Projector



Projection Distance Chart*

Screen diagonal (inch)	Display size (16:9)		Projection distance	
	W (mm)	H (mm)	Wide (m)	Tele (m)
60	1,328	747	1.78	3.66
70	1,549	872	2.09	4.28
80	1,771	996	2.40	4.89
90	1,992	1,121	2.70	5.51
100	2,214	1,245	3.01	6.13
110	2,435	1,370	3.31	6.75
120	2,656	1,494	3.62	7.36
130	2,878	1,619	3.92	7.98
140	3,099	1,743	4.23	8.60
150	3,320	1,868	4.53	9.22
160	3,542	1,992	4.84	9.84
170	3,763	2,117	5.14	10.45
180	3,984	2,241	5.45	11.07
190	4,206	2,366	5.75	11.68
200	4,427	2,490	6.06	12.30

*Projection distances are design specifications, so there is $\pm 5\%$ variation.

Specifications

		DLA-F110
Device		0.7-inch D-ILA x3
Resolution		Full HD D-ILA device (1,920 x 1,080)
Lens		2 x motorized zoom / focus f=21.4mm - 42.8mm F=3.2 - 4
Lens shift function		$\pm 80\%$ vertical and $\pm 34\%$ horizontal (motorized)
Projection size		60 - 200 inches (screen diagonal)
Light source lamp		220W ultra-high pressure mercury lamp (lamp life: approx. 3,000 hours with lamp used in Normal mode)
Brightness		1,700lm
Contrast ratio		Native: 30,000:1
Input terminals	Component	1 (RCA)
	HDMI	2 (ver.1.4a, 3D, Deep Color)
	Analog RGB (PC)	1 (D-sub 15-pin)
Output terminals	Trigger	1 (mini jack, DC12V/100mA)
	3D sync	1 (mini DIN 3-pin)
Control terminals	RS232C	1 (D-sub 9-pin)
	Remote	1 (mini jack)
	LAN (RJ-45)	1
Analogue video input signal formats		480i/p, 576i/p, 720p 50/60, 1080i 50/60
Digital video input signal formats		480i/p, 576i/p, 720p 50/60, 1080i 50/60, 1080p 24/50/60
PC input signal	HDMI	VGA, SVGA, XGA, WXGA, WXGA+, SXGA, WSXGA+, WUXGA
	Analog RGB (D-sub 15-pin)	VGA, SVGA, XGA, WXGA, WXGA+, SXGA, SXGA+, WSXGA+, 1920 x 1080, MAC 13", 16", 19"
3D format	Frame packing	1080p 24, 1080i 50/60, 720p 50/60
	Side-by-side	1080p 50/60, 1080i 50/60
	Top and bottom	1080p 24, 720p 50/60
Power consumption current		3.5A
Allowable operating temperature range		5°C to 35°C
Allowable operating humidity range		20% to 80%
Allowable storage temperature range		-10°C to 60°C
Power requirement		AC 110V - 240V, 50/60 Hz
Power consumption		350W (stand-by: 0.9W)
Dimensions: W x H x D, mm		455 x 179 x 472
Weight, kg		15.1

External Dimensions (unit: mm)

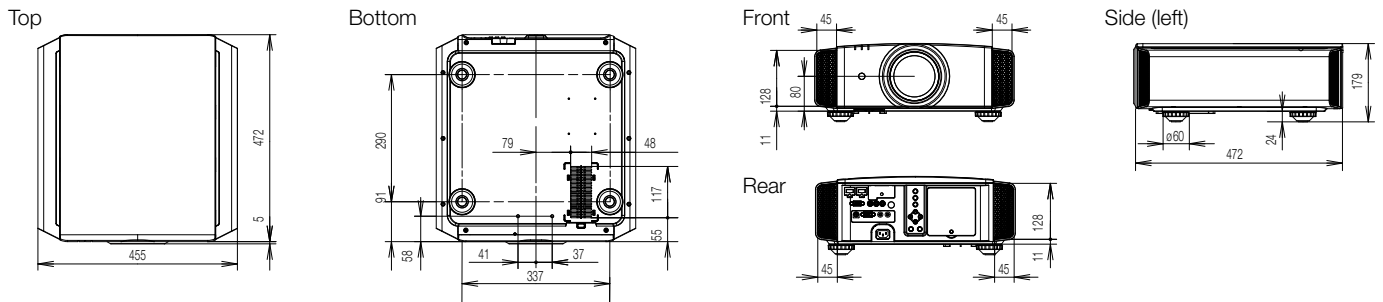

Optional Accessories



User-replaceable Lamp
PK-L2210U



3D Glasses
PK-AG1-B



3D Synchro Emitter
PK-EM1

Design and specifications are subject to change without notice. HDMI, the HDMI logo and High-Definition Multimedia Interface are registered trademarks of HDMI Licensing LLC.

The projector is equipped with a high-pressure mercury lamp, which may break, emitting a loud noise, when it is subjected to shock or after it has been used for some length of time.

Please note that, depending on how the projector is used, there can be considerable difference between individual lamps regarding how many hours they will operate before requiring replacement. The owner of the projector is responsible for all costs related to the replacement of the lamp.

• The projector lamp requires periodic replacement and is not covered by warranty.

• Please note that as the D-ILA device is manufactured using highly advanced technologies, 0.01% or fewer of the pixels may be non-performing (always on or off).

All pictures on this leaflet are simulated.

All brand or product names may be trademarks and/or registered trademarks of their respective owners. Any rights not expressly granted herein are reserved.

Copyright © 2011, Victor Company of Japan, Limited (JVC). All Rights Reserved.

JVC®

DISTRIBUTED BY