



KICKER[®]



SX AMPLIFIERS

WITH DIGITAL SIGNAL PROCESSING

WIN LOUD

OWNER'S MANUAL
SX900.2, SX600.2, SX500.2, SX400.2
STEREO AMPLIFIERS

KICKER®



SX .2 Series Amplifier Owners Manual

Two Channel Models: **SX400.2 / SX500.2 / SX600.2 / SX900.2**

Attention:

Please take a moment and record the information asked for below in the provided area. It is also a good idea to attach the original sales receipt or a copy of it to this page for future reference

If for any reason you require service on this amplifier during the warranty period, you will need to provide this information and a copy of the receipt to Kicker to validate your warranty.

ALWAYS KEEP YOUR RECEIPT!

Congratulations!

You have just purchased the latest in amplifier technology to carry the famous KICKER name. Your KICKER SX series amplifier employs the latest in DSP signal processing to give you total control over your sound. Like all KICKER products it is designed and built to give you years of powerful and trouble-free performance. This installation manual contains valuable information on how to get the most out of your new SX series amplifier.

Thanks for buying KICKER. Enjoy!

Dealer Where Purchased: _____

Purchase Date: _____

Amplifier Model Number: _____

Amplifier Serial Number: _____

FEATURES

Low Impedance Operation Stable into 2 ohm stereo or 4 ohm mono loads.

SHORT Protection Circuitry (short circuit, Over-voltage, Reverse polarity, Thermal) Protects amplifier from accidents and out of spec operation.

MOSFET Power Supply Provides high efficiency operation.

PAST (Pre Amp Signal Transfer) Output RCA jacks to pass the incoming signal to another amplifier or component.

SAMS (Stereo And Mono Simultaneously) Amplifier will operate into a bridged mono load and a stereo load at the same time.

Low Pass Filter Fully adjustable digital crossover with variable slope and crossover frequency. 30 Hz - 20 kHz in 1/12 octave spacing. OFF - 36 dB per octave slope in 6 dB increments.

High Pass Filter Fully adjustable digital crossover with variable slope and crossover frequency. 10 Hz - 16 kHz in 1/12 octave spacing. OFF - 36 dB per octave slope in 6 dB increments.

KickeQ Fully adjustable single band digital parametric equalizer with variable Q (bandwidth), variable center frequency and variable boost or cut. Q range .5 - 10 in .5 steps. Center frequency 20 Hz - 20 kHz in 1/12 octave steps. Boost or cut range +/- 18 dB.

Adjustable Phase The output phase of each channel can be set at 0 Degrees or 180 Degrees. Left and Right channels can be linked or independently adjusted.

UltraMatch Gain Structure Digital input gain control with five selectable gain ranges (1 volt, 2 volt, 4 volt, 8 volt, 16 volt) with 12 dB of adjustment in each range in .5 dB steps. Left and Right channels can be linked or adjusted independently.

SickBay and On Board Diagnostics Various tools to troubleshoot installation issues and check amp status.

Kompressor A 4-setting, user-selectable bass compressor used to fatten up your sub bass. OFF, TIGHT, CONTOUR and ATTACK with +/- 24 dB of adjustment to compensate for speaker size or listening style.

ISIS (pronounced eye-sis) (**I**ndicate **S**tatus & **I**nput **S**ettings) The user interface to view or adjust current settings and check the status of your Kicker SX amplifier.

BLAST Port (Bass Level And Signal Transfer) Provides Remote Bass Level Control and control signal transfer between multiple SX amplifiers.

EndKaps Cast aluminum, custom, removable covers to protect and hide all your wiring connections to the amplifier. Can be prepped and painted any custom color you choose.

SASA (Shake A Stick At) So many more features...it is more than you can Shake A Stick At. (It's an Oklahoma thing!) Read on to find out!

ISIS

Meet the **ISIS** interface (Indicate Status & Input Settings). The **ISIS** (pronounced eye-sis) allows you to view the current conditions and settings of your amplifier as well as change the many user-adjustable settings. The **ISIS** system consists of the VFD (Vacuum Fluorescent Display) and the nine soft touch buttons that make up the **KEYPAD**.

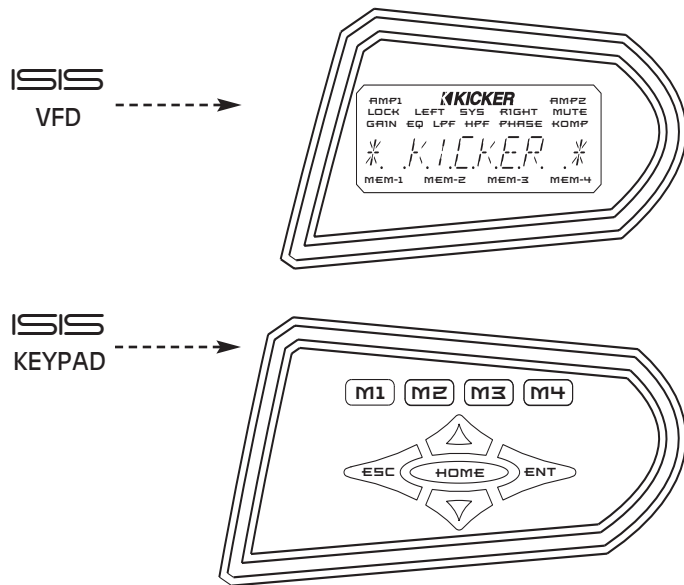

VFD DISPLAY



Here is a brief description of the indicators found on the VFD.

AMP1 - Indicates amplifier 1 is selected for adjustment. Only available in four channel amps.

AMP2 - Indicates amplifier 2 is selected for adjustment. Only available in four channel amps.

LOCK - Indicates the amplifier controls are locked out and not usable.

LEFT - Indicates an action or adjustment of the left channel.

SYS - Indicates you are in the system menu.

RIGHT - Indicates an action or adjustment of the right channel.

MUTE - Indicates you are in the mute menu or the mute function is active.

VFD DISPLAY - cont

GAIN - Indicates you are in the gain menu.

EQ - Indicates you are in the equalizer menu.

LPF - Indicates you are in the low pass filter menu.

HPF - Indicates you are in the high pass filter menu.

PHASE - Indicates you are in the phase menu.

KOMP - Indicates you are in the Kompressor menu.

MEM-1 - Memory preset 1 activated.

MEM-2 - Memory preset 1 activated.

MEM-3 - Memory preset 1 activated.

MEM-4 - Memory preset 1 activated.

KEYPAD

The keypad consists of nine buttons that allow you to adjust your amplifier.

M1 - Used to select memory preset 1 or to store current settings into preset 1.

M2 - Used to select memory preset 2 or to store current settings into preset 2.

M3 - Used to select memory preset 3 or to store current settings into preset 3.

M4 - Used to select memory preset 4 or to store current settings into preset 4.

ESC - Used to exit the current menu.

ENT - Used to enter the selected menu.

HOME - Used to return to the Main menu and other functions explained later.

UP - Used to advance up through menu selections and/or adjust amplifier controls.

DOWN - Used to advance down through menu selections and/or adjust amplifier controls.

These controls and their usage will be explained later with more detail in each menu usage section.

END PANEL VIEWS

The BLAST Port is used to connect the Remote Bass Level Controller and for transferring control signals from one SX amplifier to another SX amplifier. An RJ45 cable is required to connect the BLAST Port (Out) of one amp to the BLAST Port (In) of another. This is only required if you want to control more than one amplifier with the same Bass Level Controller. More details on this further in the manual.

The speaker terminals are custom-machined connectors with full protective shrouds and are designed to accept heavy gauge speaker wire assures maximum power transfer and damping with minimal power loss.

Gold-plated RCA input connectors and **PAST** jacks provide solid input and output connections for your pre-amp signal.

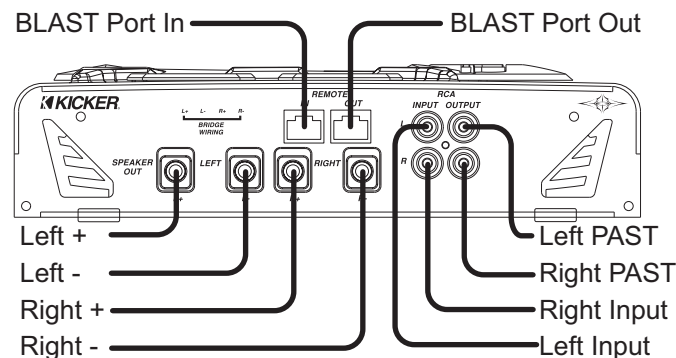

Custom-machined power block accepts up to a 2 Ga wire for both power and ground connections and up to an 8 Ga for remote turn-on assures maximum power transfer with minimal loss.

On-board fusing (number of fuses vary by amp size) to protect amplifier against over current conditions and reverse polarity.

Power LED indicates amplifier is powered up and operating.

Check Fuse LED indicates a fault with the end panel fuses. This could be fuses which are not seated properly, faulty fuses or blown fuses.

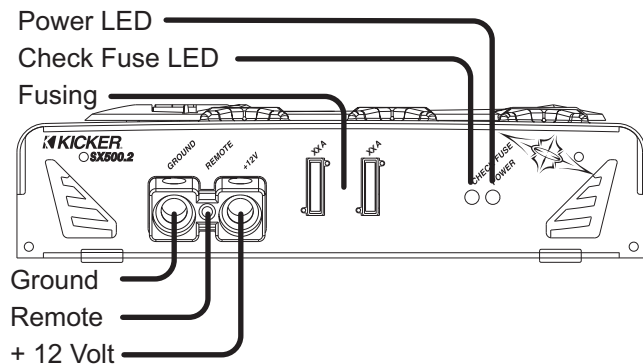

MOUNTING

When selecting a location to mount your Kicker amplifier be sure it is structurally sound and that there are no items behind the area that could be damaged by the screws. Check for wiring, brake lines, fuel lines, gas tanks, etc.

All amplifiers generate heat under normal operation. Be sure to choose a location that allows adequate ventilation for the amplifier. Also consider that the air temperature inside an automobile's trunk can reach upwards of 140 degrees Fahrenheit. An amplifier mounted in the trunk may require additional cooling such as extra fans moving air around the amplifier's chassis or ventilating the trunk to exchange the hot air in the trunk for cooler air outside. If possible, mounting the amp in the passenger compartment will allow cooler operation.

Remember that the controls on top of the amp will need to be accessible for adjustment later. Keep this in mind as you choose your amplifier's mounting location.

Now that you are ready to mount your amplifier, use the supplied 3mm allen wrench to remove the amplifier EndKaps. This will give you access to the mounting holes in the amplifier and all wiring connections.

See Fig. 1

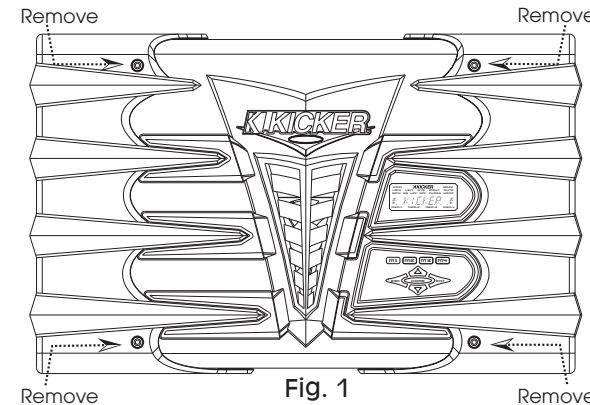

Fig. 1

With the EndKaps removed, you now have access to the four mounting holes in the mounting feet and all wiring connections. Drill 4 holes using a 7/64" drill bit and use the supplied #8 screws to mount the amplifier.

See Fig. 2

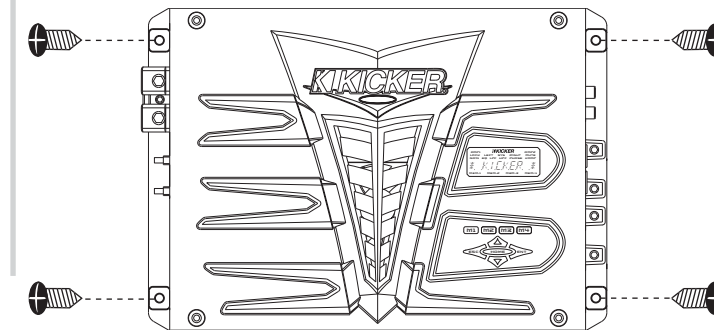
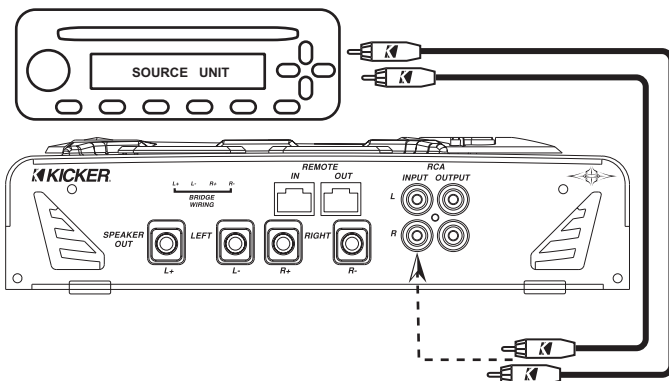

Fig. 2

WIRING

Signal is input into the amplifier using the low level RCA input connections. If your source unit does not have RCA output connectors you will need to use a Hi-Lo level signal adapter. See your Kicker dealer for more details on this.

The output (PAST) RCA jacks provide an unaltered signal output to feed another amplifier or component.



The use of twisted pair interconnects is recommended for all installations to minimize noise. When routing these cables through the automobile, try to keep them away from factory wiring harnesses and other power wiring. If you need to cross any of this wiring do so at a 90 degree angle to reduce the possibility for noise problems.

When working with power connections it is always recommended that you disconnect the battery to prevent accidents.

The ground should be connected to the amplifier first before making any of the other connections. This wire should be as short as possible (24 inches or less) and connected to a paint/corrosion free solid metal area of the car's chassis. Use the same gauge wire as recommended for the amplifier's power connection to the battery. Adding an additional ground wire between the car battery's negative post and the car chassis of this same gauge (or larger) is also recommended.

If you ever need to remove the amp from the vehicle after it has been installed, the ground wire should be the last wire disconnected from the amplifier, just the opposite of when you installed it.

A fuse must be installed within 18 inches of the battery to protect the power wire feeding your amplifier. This fuse should be of at least the same value used in the amplifier but no higher than the capacity of the power wire. See the charts below for wire size and fusing recommendations.

Model	Fuse Size	Wire Size
SX400.2	50A	4 GA
SX500.2	60A	4 GA
SX600.2	80A	4 GA
SX900.2	120A	2 GA

Wire Size	Length	Maximum Fuse
8 Ga	Less than 10 feet in length	70 Amps
4Ga	10 feet in length	175 Amps
2 Ga	20 feet in length	250 Amps
0Ga	40 feet in length	400 Amps
8 Ga	10 feet to 20 feet in length	40 Amps
4 Ga	20 feet in length	90 Amps
2 Ga	40 feet in length	150 Amps
0 Ga	80 feet in length	200 Amps

SYSTEM DIAGRAMS

TWO CHANNEL OPERATION (STEREO)

SX.2 series amplifiers are capable of operating into a minimum impedance of 2 ohms per channel in stereo operation.

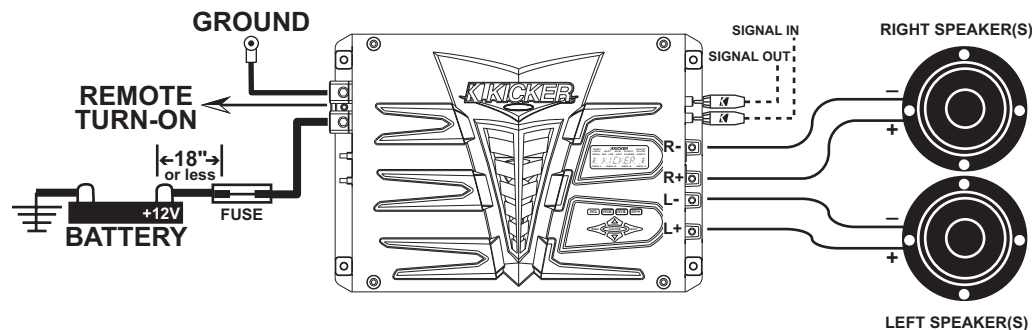

BRIDGED OPERATION (MONO)

SX.2 series amplifiers are capable of operating into a minimum impedance of 4 ohms when in bridged operation.

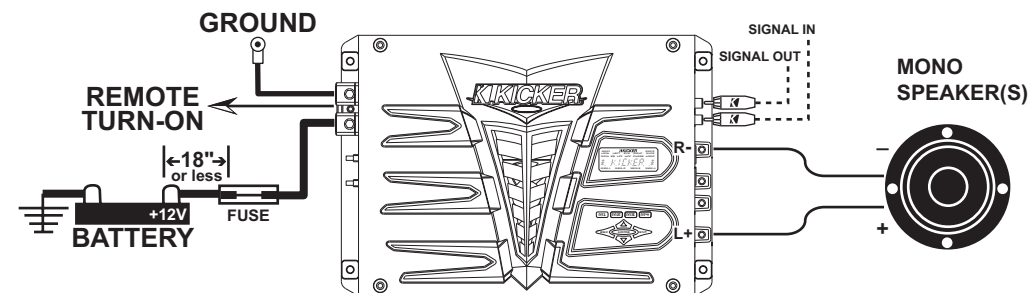

STEREO AND MONO SIMULTANEOUSLY (SAMS)

SX.2 series amplifiers are capable of operating into a minimum impedance of 4 ohms mono and 2 ohms stereo simultaneously with the use of passive crossovers.

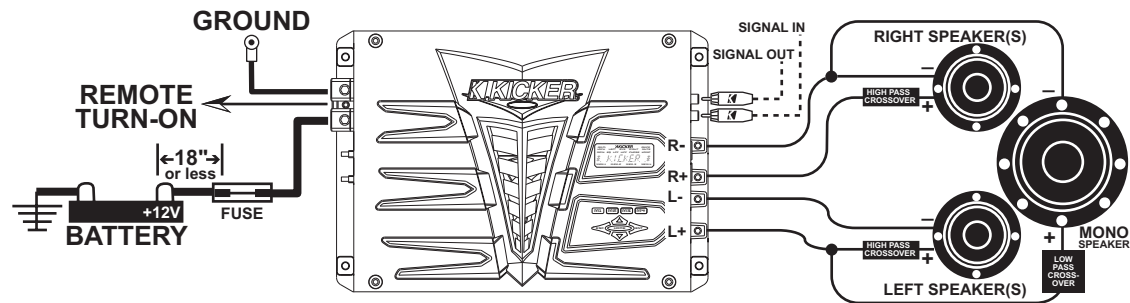

These are just a few of the many ways you can use your SX.2 series Kicker amplifier. These system diagrams are designed to give you a basic understanding of the most common uses for this amplifier. For more complex systems please visit your local authorized Kicker dealer. You can also download the SX Technical Manual from our website at www.kicker.com for more detailed information and complex system diagrams.

USING THE SIGNAL OUTPUT JACKS (PAST)

The Output (Pre Amp Signal Transfer) RCA jacks allow you to send the incoming signal from one Kicker SX series amplifier to another amplifier or processor without the need for Y cables. The signal from the PAST jacks is identical to the signal fed to the amplifier via its RCA input jacks and is not affected by any of the amplifier's built-in digital signal processing.

Most head units with high voltage outputs should be capable of driving up to ten amplifiers in a chain.

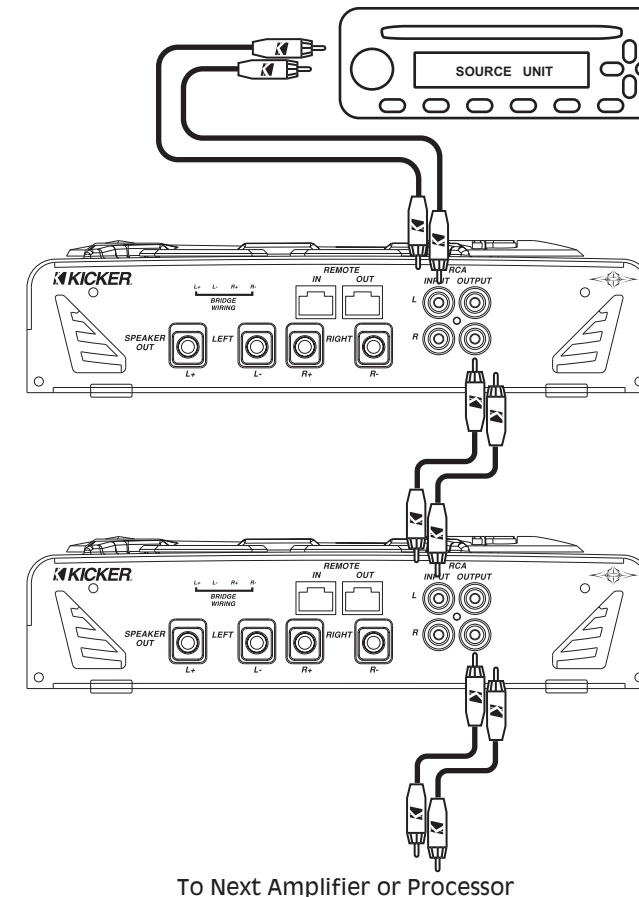

USING THE REMOTE BASS LEVEL CONTROL & BLAST

You can use the Remote Bass Level Control to control the output of your amplifier from the front of the car.

Mount the controller by simply screwing the metal bracket to the chosen location and then slide the housing onto the bracket until it snaps into place.

Route the cable from the controller to the BLAST input jack on the amplifier chassis. That's it.

If you wish to control more than one amplifier with your remote, you will simply need to use a RJ45 cable (not supplied but available at any Radio Shack, computer store or electronics center) to connect the BLAST output jack of the first amp to the BLAST input jack of the next amplifier.

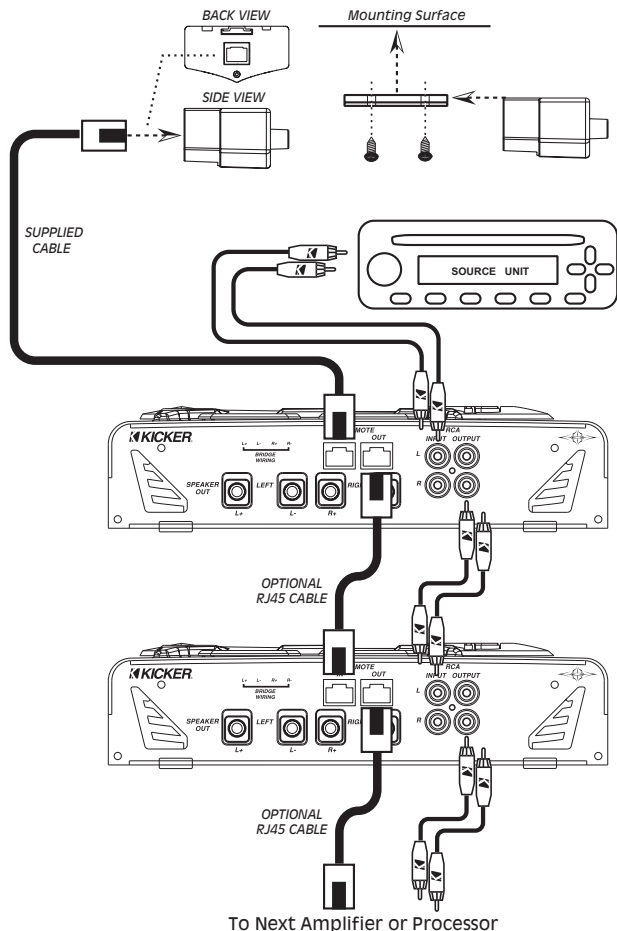

NAVIGATION

Your KICKER SX series amplifier uses the latest in Digital DSP control and provides you with valuable operational information about your amplifier, real-time diagnostics and a full multi-level menu-driven operating system to access and adjust your amplifier.

The menu system is designed in layers. There is a starting point and you keep drilling down until you get to the menu item you want to view or change. This menu tree is an example of how the SX menu structure is set up.

NOTE: Not all the menus and menu items are shown below.

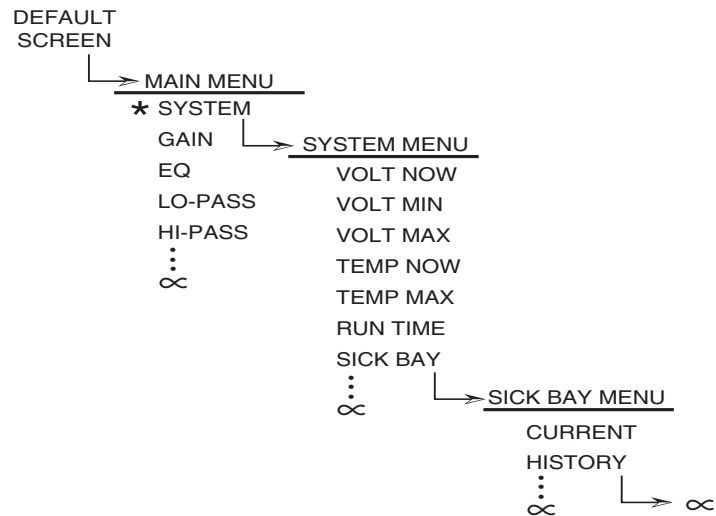

As you can see there can be an infinite number of menu levels and each one of these menu levels can have an infinite number of its own items.

Navigating this simple menu structure is very easy using the 5-way keypad.



You use the **UP** and **DOWN** keys to scroll through the available menu items, and the **ENT** key is used to select that menu item. The **ESC** key backs you up one menu level from where you are, and the **HOME** key can return you all the way to MAIN MENU by pressing and holding it for 1.5 seconds.

For example let's begin at the DEFAULT SCREEN; our goal is to get to the HISTORY menu. Pressing the **ENT** key would get us to MAIN MENU. Now use the **UP** and **DOWN** keys to scroll to SYSTEM, and then press the **ENT** key. Now you are in the SYSTEM MENU. Using the **UP** and **DOWN** keys again you scroll to SICK BAY and press the **ENT** key. You are now in the SICK BAY MENU. Use the **UP** and **DOWN** keys again to scroll to HISTORY and then press the **ENT** key. That's it! You are there.



This is how you view information and change settings in your KICKER SX amplifier.

Continuing our example, we are now in the HISTORY item in the SICK BAY MENU. If we press the **ESC** key we would go back up to the SICK BAY MENU. If we press the **ESC** key again we would go to the SYSTEM MENU. One more press of the **ESC** key and we are in the MAIN MENU.



Let's start at the HISTORY item in the SICK BAY MENU again but instead press and hold the **HOME** key for 1.5 seconds. Doing this will take us all the way back to the MAIN MENU in one key press. Pressing and



PRESS & HOLD

holding the **HOME** key will return you all the way back to the MENU ITEM you started with in the MAIN MENU, no matter how deep in the menu level structure you are. Pretty cool!

This is a very quick way to return to the MAIN MENU after drilling down several menu layers to view or change an item.

When adjusting any amplifier control the **UP** and **DOWN** arrow keys have 2 speeds, normal and accelerated.

Pressing and releasing the key repeatedly will scroll through the menu items at normal speed.



PRESS & RELEASE

Pressing the key and holding it in for longer than 1.5 seconds will activate the accelerated scrolling mode and scroll through the menu items at a much faster rate. Releasing the key will return it to normal speed mode.



PRESS & HOLD

Don't try to scroll through every 1/12 octave step without it!

Menu System

The menu system layout is as follows:

DEFAULT - This menu is displayed when your amp is operating and no adjustments are being made to your amplifier. This information scrolls through the display one after the other and then repeats.

- 1.) *KICKER* - Hey, we needed a brand plug for us since this amp is *soooooo* cool!
- 2.) *XX X VOLTS* - Displays the current voltage at the amplifier's + 12 volt battery input terminal.
- 3.) *XX X DEG F* or *XX X DEG C* - Displays the current temperature of the amplifier in celsius or fahrenheit.
- 4.) *AMP NAME* - Model name of the amplifier or the name you have changed it to.
- 5.) *MEMORY NAME* - Current memory preset in use (if any) or the name you have changed it to.



If you want to freeze the scrolling display simply press the **HOME** key and the scrolling will stop.

Now you can manually select the item you wish to have displayed by using the **UP** or **DOWN** keys.



If you want the display to continue scrolling simply press the **HOME** key again.

MAIN - This menu is the first menu accessed from the DEFAULT menu and is the gateway to all the settings and information on your SX series amplifier.

To enter the MAIN menu simply press the **ENT** key while in the DEFAULT menu.



The available selections in the MAIN menu are:

```
SYSTEM
GAIN
EQ
LO-PASS
HI-PASS
PHASE
MUTE
KOMPRESSOR
SECURITY
```

Use the **UP** and **DOWN** arrow keys to scroll through the available selections in the MAIN menu.

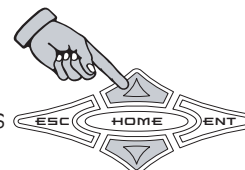

When you have the menu item selected that you want to view or adjust simply press the **ENT** key to select it.



SYSTEM MENU - This menu item contains many diagnostic tools and first time setup options. Use the **UP** and **DOWN** arrow keys to scroll through the options and press **ENT** to select. Press the **ESC** key to return to the SYSTEM menu.

- 1.) VOLT NOW** - Displays the current voltage at the amplifiers +12 volt terminal.
- 2.) VOLT MIN** - Displays the lowest voltage seen at the amplifiers +12 volt terminal since being installed.
- 3.) VOLT MAX** - Displays the highest voltage at the amplifiers +12 volt terminal since being installed.
- 4.) TEMP NOW** - Displays the current temperature of the amplifier.
- 5.) TEMP MAX** - Displays the highest temperature the amplifier has reached since being installed.
- 6.) RUN TIME** - Displays the total time the amplifier has been powered up since installation in 1/10th of an hour increments
- 7.) SICK BAY** - Contains several diagnostic tools. Once in this menu you use the **UP** and **DOWN** keys to scroll through **CURRENT**, **HISTORY** and **PINK NOISE** options. Press the **ENT** key to select.



7a.) CURRENT shows amplifiers current status or fault code. The 6 possible codes are:

NORMAL - No problem, normal operation.
THERMAL - Thermal cutoff protection engaged.
SHORT - Short circuit protection engaged.
HI-VOLT - High voltage protection engaged.
FUSE - Faulty or blown power fuse.
SERVICE - Amp requires service by KICKER.

When you are done viewing the current status press the **ESC** key to return to the SICK BAY menu.



7b.) HISTORY logs the last 5 fault codes and how long ago they happened when compared to the RUN TIME log.

Use the **UP** and **DOWN** keys to select the **HISTORY** log entry you want to view.



Press and hold the **ENT** key to view the time it happened.



When you are done viewing the history press the **ESC** key.



SICK BAY - cont

7c.) PINK NOISE is a built in pink noise generator to test operation of the amplifier

Use the **UP** and **DOWN** keys to select **NOISE ON** or **NOISE OFF**.



When the PINK NOISE is ON the **LEFT** and **RIGHT** indicators in the **ISIS** VFD will blink on and off.



When you are done using the PINK NOISE generator press the **ESC** key to return to the SICK BAY menu.



NOTE...

If you exit the SICK BAY menu with the PINK NOISE generator still on, the **LEFT** and **RIGHT** **ISIS** VFD indicators will remain blinking as a reminder.

8.) AMP NAME - Here you can assign a unique name to your KICKER SX amplifier. This name will replace the model name in the DEFAULT screen. If you change your mind and do not want to change the name, press and hold the **HOME** key for 1.5 seconds BEFORE making any changes.

The **ESC** and **ENT** keys move the cursor left or right to select which character to change.



Use the **UP** and **DOWN** keys to change the character displayed [A, B, C...1, 2, 3...ETC]



When you are finished press and hold the **HOME** key for 1.5 seconds to save your new amplifier name.



9.) **MEM NAME** - Here you can change the names of the memory locations. The factory defaults are

MEMORY--1
MEMORY--2
MEMORY--3
MEMORY--4



Use the **UP** and **DOWN** keys to select the memory location name you want to change and then press the **ENT** key to select it. If you change your mind and do not want to change the name, press and hold the **HOME** key for 1.5 seconds BEFORE making any changes.



The **ESC** and **ENT** keys move the cursor left or right to select which character to change.



Use the **UP** and **DOWN** keys to change the character displayed
(A, B, C... 1, 2, 3... ETC)



PRESS & HOLD

When you are finished press and hold the **HOME** key for 1.5 seconds to save your new memory name.

Repeat the above steps to rename the other presets.

10.) **REMOTE ADR** - This feature is currently not used but is reserved for future expansion.

11.) **GAIN RANGE** - Sets the input voltage window of the UltraMatch gain control. Possible choices are:

1, 2, 4, 8, 16

Select the one closest to the maximum RCA input voltage you expect to send to the amplifier.

Use the **UP** and **DOWN** keys to select your voltage. Press the **ESC** to return to the MAIN menu.



12.) **BYPASS DSP** - Bypasses all DSP processing and sends the input signal directly to the amplifier.

Use the **UP** and **DOWN** keys to select **BYPASS ON** or **BYPASS OFF**. Press the **ESC** key to return to the MAIN menu.



13.) **KOMP ADJ** - This adjusts the KOMPRESSOR activation threshold. Range is +24 dB to -24 dB to allow for different sized speakers or listener tastes. 0 is the default factory setting.



Use the **UP** and **DOWN** keys to select your setting and then press the **ESC** to return to the MAIN menu.

14.) **DISPLAY** - Several options to allow customizing the amplifier's VFD display.

14a.) **BRIGHTNESS** - Adjust the intensity level of the **ISS** VFD display. Five selectable levels.

MINIMUM - dimmest setting.

LOW

MEDIUM

HIGH

MAXIMUM - brightest setting.

14b.) **TEMP C/F** - Selects between Celsius (**CELSIUS**) or Fahrenheit (**FAHRENHEIT**) for temperature readouts.

14c.) **HOLD TIME** - Adjusts the speed of the scroll in the Default Screen display. Determines how long each menu item stays in the display before scrolling to the next item. Adjustable from 1 - 11 seconds.

14d.) **SCREENSAVER** - Option to turn on or off the screensaver. When on (**AUTO**) the display will go to sleep when there is no button activity for 60 seconds. Pressing any button once will wake up the display. The **OFF** selection turns off the screensaver and the display is always on.

15.) **LOCK CODE** - Set your own lock code! The factory default is **123** but you can change it and create your own code with up to 10 characters.

The **ESC** and **ENT** keys move the cursor left or right to select which character to change.



Use the **UP** and **DOWN** keys to change the character displayed
(A, B, C... 1, 2, 3... ETC)

When you are finished press and hold the **HOME** key for 1.5 seconds to save your new amplifier lock code. **IMPORTANT!!!** Be sure to write this code down for future reference.



PRESS & HOLD

16.) **RESET AMP** - This option resets all adjustable settings back to their original factory defaults.

Use the **UP** and **DOWN** keys to select **SKIP RESET** or **DO RESET** and then press the **ENT** key to perform the selected action.



17.) **ABOUT** - This menu item will display information about the DAP (Digital Audio Processor) hardware, software and build date.



Use the **UP** and **DOWN** keys to view the DSP Version, Software Version, Hardware Version and Build Date. Press the **ESC** key to return to the MAIN menu.

GAIN MENU - Here is where you adjust your amplifier's gain control settings.

Press the **ENT** key to enter the GAIN menu.



Use the **UP** and **DOWN** keys to scroll through **LEFT** channel, **RIGHT** channel or **BOTH** options and then press the **ENT** key to select.



Now use the **UP** and **DOWN** keys to increase or decrease the gain of the selected channel(s) in .5 dB increments from 0 dB to +12 dB. (.0 to 12.0)



Press the **ESC** key to return to the **LEFT**, **RIGHT**, **BOTH** options menu. You can now adjust another channel on this amplifier.



When you are done adjusting the gain press the **ESC** key while in the GAIN menu to return to the MAIN menu.



NOTE...

While adjusting the GAIN you will notice the **GAIN** indicator on the **ISIS** VFD display is lit. This indicates you are in the GAIN menu.

The **LEFT** and/or **RIGHT** indicator will light up to indicate which amplifier channel(s) you are currently adjusting.

EQ MENU - Here you can adjust the single band parametric equalizer. Your options are **FREQUENCY**, **BANDWIDTH** and **BOOST/CUT**.

Press the **ENT** key to enter the EQ menu.



Use the **UP** and **DOWN** keys to choose one and press the **ENT** key to select it.



FREQUENCY selects the center frequency of the EQ and can be set at any 1/12th octave frequency from 20 Hz - 20 kHz. (20 Hz to 20325 Hz)

Use the **UP** and **DOWN** keys to select your frequency. Press the **ESC** to return to the EQ menu.



BANDWIDTH (better known as Q) can be set from .5 to 10 in .5 increments. In simple terms, lower Q effects more frequencies around the center frequency while higher Q effects fewer frequencies around the center frequency.

Use the **UP** and **DOWN** keys to select your Q value. Press the **ESC** to return to the EQ menu.



BOOST/CUT is how much you want to boost or cut the equalizer and has a range of -18 dB to +18 dB in .5 dB steps.

Use the **UP** and **DOWN** keys to adjust each setting and the **ESC** key to return to the EQ menu.



When you are done adjusting the EQ press the **ESC** key while in the EQ menu to return to the MAIN menu.



NOTE...

While adjusting the EQ you will notice the **EQ** indicator on the **ISIS** VFD display is lit. This indicates you are in the EQ menu.

LO-PASS MENU - Here is where you adjust the low pass crossover.

Press the **ENT** key to enter the LO-PASS menu.



Use the **UP** and **DOWN** keys to scroll through *FREQUENCY* and *SLOPE*. Press the **ENT** to select the one you want to adjust.



FREQUENCY selects the crossover point and can be set at any 1/12th octave frequency from 30 Hz to 20 kHz. (30 Hz to 20325 Hz)

Use the **UP** and **DOWN** keys to select your frequency. Press the **ESC** to return to the LO-PASS menu.



SLOPE selects the rolloff of the crossover and can be set from OFF to 36 dB in 6 dB steps.

Use the **UP** and **DOWN** keys to select your slope. Press the **ESC** to return to the LO-PASS menu.



When you are done adjusting the EQ press the **ESC** key while in the EQ menu to return to the MAIN menu.



NOTE...

While adjusting the LO-PASS crossover you will notice the *LPF* indicator on the *ISIS* VFD display is lit. This indicates you are in the LO-PASS crossover menu.

The KICKER SX amplifier monitors and prevents any low pass crossover point from being any closer than 1/3 octave from the high pass crossover point. If you cannot set the low pass crossover where you want then check the *HPF* indicator and see if it is flashing. If it is then you need to go to the HI-PASS menu and raise the high pass crossover point.

This is done as a safety precaution to prevent a notch filter condition.

HI-PASS MENU - Here is where you adjust the high pass crossover.

Press the **ENT** key to enter the HI-PASS menu.



Use the **UP** and **DOWN** keys to scroll through *FREQUENCY* and *SLOPE* and press the **ENT** to select the one you want to adjust.



FREQUENCY selects the crossover point and can be set at any 1/12th octave frequency from 10 Hz to 16 kHz. (10 Hz to 16132 Hz)

Use the **UP** and **DOWN** keys to select your frequency. Press the **ESC** key to return to the HI-PASS menu.



SLOPE selects the rolloff of the crossover and can be set from OFF to 36 dB in 6 dB steps.

Use the **UP** and **DOWN** keys to select your slope. Press the **ESC** to return to the HI-PASS menu.



When you are done adjusting the EQ press the **ESC** key while in the EQ menu to return to the MAIN menu.



NOTE...

While adjusting the HI-PASS crossover you will notice the *HPF* indicator on the *ISIS* VFD display is lit. This indicates you are in the HI-PASS crossover menu.

The KICKER SX amplifier monitors and prevents any high pass crossover point from being any closer than 1/3 octave from the low pass crossover point. If you cannot set the high pass crossover where you want then check the *LPF* indicator and see if it is flashing. If it is then you need to go to the LO-PASS menu and lower the low pass crossover point.

This is done as a safety precaution to prevent a notch filter condition.

PHASE MENU - Here you can switch the polarity of each channel(s) output between 0 or 180 degrees.

Press the **ENT** key to enter the PHASE menu.



Use the **UP** and **DOWN** keys to scroll through *BOTH*, *LEFT* and *RIGHT*. Press the **ENT** to select the one you want to adjust.



Use the **UP** and **DOWN** keys to select from *0 DEGREE* or *180 DEGREE*. Press the **ESC** key to make your selection and return to the PHASE menu.

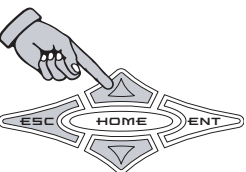

You can now select another channel to adjust or press the **ESC** key to return to the MAIN menu.



NOTE...

While adjusting the PHASE you will notice the *PHASE* indicator on the *ISIS* VFD display is lit. This indicates you are in the PHASE menu.

There is also a *LEFT* and a *RIGHT* indicator that will light up to let you know which channel (Left and/or Right) that you are currently adjusting.

MUTE MENU - Here you can mute each channel(s) output for setup or testing purposes.

Press the **ENT** key to enter the MUTE menu.



Use the **UP** and **DOWN** keys to scroll through *BOTH*, *LEFT* and *RIGHT*. Press the **ENT** to select the one you want to adjust.



Use the **UP** and **DOWN** keys to select from *MUTE ON* or *MUTE OFF*.



Press the **ESC** key to make your selection and return to the MUTE menu.



You can now select another channel to adjust or press the **ESC** key to return to the MAIN menu.



MUTE MENU - cont.

NOTE...

While adjusting the MUTE you will notice the *MUTE* indicator on the *ISIS* VFD display is lit. This indicates you are in the MUTE menu.

There is also a *LEFT* and a *RIGHT* indicator that will light up to let you know which channel (Left and/or Right) that you are currently muting.

If you exit the MUTE menu with any channel(s) muted, the *LEFT* and/or *RIGHT* indicators will flash to indicate this.

KOMPRESSOR MENU - Here you can select which Kompressor setting you wish to use. The SX amplifier utilizes a full digital compressor circuit to tweak the amplifier and the sound to your unique needs.

Press the **ENT** key to enter the KOMPRESSOR menu.



Use the **UP** and **DOWN** keys to scroll through *TIGHT*, *CONTOUR*, *ATTACK* and *OFF*.



Press the **ESC** key to accept your selection and return to the MAIN menu.



NOTE...

While adjusting the Kompressor you will notice the *KOMP* indicator on the *ISIS* VFD display is lit. This indicates you are in the KOMPRESSOR menu.

See the specifications pages for a brief description of each Kompressor setting and some general guidelines for their use.

SECURITY MENU - Here you can lock down your amplifier to prevent any access to the settings. The DEFAULT screen is still active and you can select any of the four presets... but that is it!

Press the **ENT** key to enter the KOMPRESSOR menu.



Use the **UP** and **DOWN** keys to select *LOCK IT UP* or *DON'T LOCK* and then press the **ENT** key to accept your setting.



If you selected *LOCK IT UP* the display will now show *UNLOCK* and the **LOCK** indicator will be on. The menus are now locked. Press the **ESC** key to return to the DEFAULT scrolling screen.



If you selected *DON'T LOCK* then you will return to the MAIN menu and the amplifier will remain unlocked.

NOTE...

While your amplifier is in lock down you will notice the *LOCK* indicator on the *ISIS* VFD display is lit. This indicates your amplifier is locked down and will require a code to unlock it before any adjustments can be made.

UNLOCK AMPLIFIER

You do remember your lock code right? You better because that is now the only way in! If you have not changed it then it is still at the factory default of *123*.

To unlock your amplifier press the **ENT** key. The display will show *UNLOCK*. Press the **ENT** key again. You will now enter your code to unlock the amplifier.



The **ESC** and **ENT** keys move the blinking cursor left or right to select which character to enter.



Use the **UP** and **DOWN** keys to enter the character. (A, B, C... 1, 2, 3...etc)



When you are finished press and hold the **HOME** key for 1.5 seconds to enter your unlock code.



If the code is correct the amp will unlock and drop you back into the security menu. If not, then read on...

UNLOCK AMPLIFIER - cont.

If you enter the wrong code the display will flash the message *BAD CODE* and then return you to *UNLOCK* screen.



Press the **ENT** key to enter your lock your code again.



Enter your code again making sure to place the correct character in the correct position in the display. Blank spaces count as part of the code so be sure you are entering it correctly.

Press the **HOME** key and try again. If you have found your error then the amp will unlock. If not, the flashing *BAD CODE* will greet you and you can try again.

If you have tried several times (several is defined as more than 3...less than 10) and you still can not unlock your amplifier, this more than likely means means you have forgotten your lock code.

You will need to call KICKER directly at (405) 624-8583 to handle this situation. You will need your amplifier's serial number AND your receipt as the guys and gals answering the phone will need this information from you to help you out.

So...before you call, gather this information up and have it ready to save us some time on the phone. Cool? Cool!

Better yet, take the time **RIGHT NOW** to fill out the first page in this manual and **STAPLE** your receipt to it. That way if or when you need service (like forgetting your lock code) you will have all the information you need right there in front of you.

MEMORY PRESETS

There are four memory preset keys each with an indicator above it in the ISIS VFD display. The indicator will illuminate if that memory preset is currently in use.

Each preset stores all the values for each of the following amplifier controls:

- *.) GAIN
- *.) EQ
- *.) LO-PASS
- *.) HI-PASS
- *.) PHASE
- *.) MUTE
- *.) KOMPRESSOR

This gives you the ability to dial in four completely different amplifier settings and store them in presets for instant recall later.

It's like a preset for your favorite radio stations...only better!

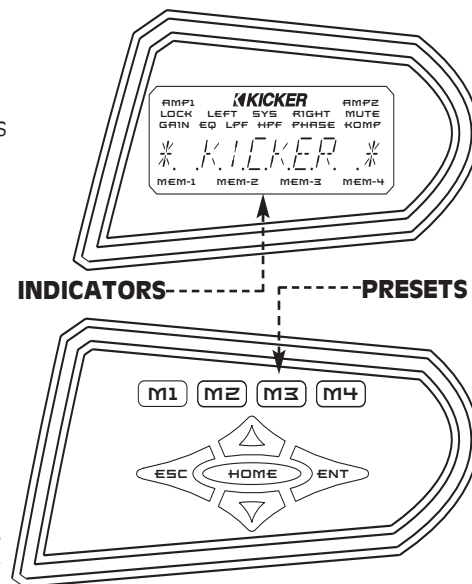

STORING A PRESET

Make all the adjustments you want to have stored in the preset and return to the DEFAULT screen.

To store your settings into a preset simply press and hold the desired memory key until the VFD display flashes *STORED*. Then release the memory key. The indicator which matches the preset you used will illuminate.

RECALLING A PRESET

To recall a memory preset simply press and release the key. The matching indicator will light up and the amplifier will change all the corresponding controls to the values assigned to the memory preset.



PRESET PRESETS

Ok, we know that sounds like a certain pizza commercial, but seriously the four memory presets come with settings already in them.

You can use these as a starting point to do your own tweaking or for quick push-a-button-and-be-done setup.

Any preset you store will replace the ones that come from the factory. You can reset all four preset back to factory defaults anytime simply by doing a reset in the RESET AMP menu.

Here are the settings in each preset from the factory.

	MEMORY-1	MEMORY-2	MEMORY-3	MEMORY-4
GAIN LEVEL	6 DB	6 DB	6 DB	6 DB
EQ FREQUENCY	40 HZ	40 HZ	40 HZ	40 HZ
EQ BOOST/CUT	FLAT	FLAT	FLAT	FLAT
EQ BANDWIDTH	3	3	3	3
LO-PASS SLOPE	OFF	OFF	24 DB	24 DB
LO-PASS FREQ	20325 HZ	20325 HZ	84 HZ	177 HZ
HI-PASS SLOPE	12 DB	24 DB	24 DB	24 DB
HI-PASS FREQ	25 HZ	84 HZ	25 HZ	84 HZ
PHASE L&R CH.	0 DEGREE	0 DEGREE	0 DEGREE	0 DEGREE
MUTE L&R CH.	OFF	OFF	OFF	OFF
KOMPRESSOR	OFF	OFF	OFF	OFF
KOMP ADJ.	0 DB	0 DB	0 DB	0 DB

In more general terms, each preset offers you these options.

Memory-1 sets the amplifier into full-range mode with a infrasonic filter (often called subsonic filter) to protect the speakers from harmful ultra-low frequencies.

Memory-2 sets the amplifier into low-pass operation with a infrasonic filter. For use when the amplifier is driving a subwoofer.

Memory-3 sets the amplifier into high-pass operation. Used for powering up a set of coaxial or component speakers when another amp is driving a subwoofer.

Memory-4 sets the amplifier up for mid-bass duty. Perfect for a set of KICKER mid-bass drivers.

As stated before you can always start with one of these preset, tweak it to fit your installation and then save your settings into a new preset.

TROUBLESHOOTING

If your amplifier does not appear to be working, check obvious things first such as blown fuses, poor or incorrect wiring connections, crossovers set improperly, gain controls improperly set, etc.

There are two LEDs on the end panel of your KICKER SX series amplifier, one green and one red. The green LED indicates the amplifier is turned on. The red LED indicates that there is a fault condition with the end panel fuses and they need checked.

The power indicator on top of the amplifier which illuminates the model badge follows the same function as the green LED.

○Green LED off, no output:

- ↻ With a Volt Ohm Meter (VOM) check:
 - ↻ + 12 volt power terminal (should read +12V to +16V).
 - ↻ Remote turn-on terminal (should read +12V to +16V).
 - ↻ Ground terminal to chassis ground (should read 0).

○Green LED on, no output:

- ↻ Check amp status in SICK BAY.
- ↻ Check GAIN RANGE in SYSTEM menu.
- ↻ Check GAIN LEVEL in GAIN menu.
- ↻ Check if MUTE is activated.
- ↻ Test amp using PINK NOISE in SICK BAY menu.
 - ☑ If amp makes noise using PINK NOISE then:
 - ↻ Check RCA cable and connections.
 - ↻ Check for signal on RCA cable with VOM in AC position.

- ↻ Substitute known good source unit.
- ☑ If amp does not make noise using PINK NOISE then:
 - ↻ Check speaker connections.
 - ↻ Test speaker outputs with known good speaker.

○Other Symptoms:

- ☑ Amp is very hot, no output.
 - ↻ Thermal protection is engaged. Check SICK BAY to verify. Check for proper impedance at speaker terminals. Also check for adequate airflow around amplifier.
- ☑ Amp shuts down while vehicle is running.
 - ↻ Over Voltage protection engaged. Check SICK BAY to verify. Voltage to the amplifier is not within the 9-16 volt operating range. Have automobile charging/electrical system inspected.
- ☑ Amp only plays at low volume levels.
 - ↻ Short circuit protection engaged. Check SICK BAY to verify. Check for speaker wires shorted to each other or the vehicle chassis. Damaged speakers or operating amplifier below minimum recommended impedance will also cause this.
- ☑ Weak bass output.
 - ↻ Change the phase of the LEFT channel in the PHASE menu. If bass improves then one speaker channel is out of phase (polarity). You can leave PHASE changed for this channel to fix the problem or better yet; Check speaker connections to amp and speakers to determine which one is wrong and correct. Be sure to set the PHASE of the LEFT channel back to original setting after correcting wiring connections.

- Alternator noise (whining sound that varies with engine RPM):
 - ↻ Check for damaged RCA cables.
 - ↻ Check routing of RCA cable.
 - ↻ Check source unit for good ground.
 - ↻ Check GAIN RANGE in SYSTEM menu, turn down if set too high.
 - ↻ Check GAIN in MAIN MENU, turn down if set too high.

CAUTION: When jump-starting the vehicle, be sure that connections made with jumper cables are correct. Improper connections (+ to - & - to +) will result in blown amplifier fuses as well as failure to other systems in the vehicle.

If you have more questions about the installation and operation of your new KICKER amplifier, see the Authorized KICKER Dealer in your area. You may also call our Technical Services Line at (405)624-8583 for assistance or visit our website at www.KICKER.com

KOMPRESSOR

Here is a brief explanation of each KOMPRESSOR setting.

CONTOUR - This preset applies expansion below the threshold point to provide a fuller sound at lower volume levels. Effect decreases at higher volume levels. Nice effect for someone wanting a fuller sound at low to moderate listening levels.

ATTACK - This preset applies expansion above the threshold point to provide a nice quick punch or attack to the music. Effect increase with higher volume levels. Like music with a quick and punchy sound? Give this one a try.

RED-LINE - Provides a quick clamp to dynamic peaks while still allowing a full sound to come through. Effect increases at higher volume levels. Like to play it loud but want to protect your speakers? Want low level details to come through over road noise? Want a more even volume level to your music? All can be achieved with this preset.

OFF - Pretty much says it all. This turns the **KOMPRESSOR** off. This is the factory default setting.

After selecting your KOMPRESSOR setting you can adjust its effect using the KOMPRESSOR ADJUSTMENT (*KOMP ADJ*) setting located in the SYSTEM menu. There you can change the threshold point for each of these settings to customize the KOMPRESSOR effect to fit your speakers, car or personal tastes.

A few words on the Kompressor. The effect is most noticeable in the bass area of your music and the descriptions above apply to that area of your music (Bass/Midbass). You can use the Kompressor in any amplifier configuration (Low Pass, High Pass, Band Pass or Full Range) but we feel the best results are obtained when with the amp is in a Low Pass (subwoofer) or Band Pass (midbass) situation.

A few exceptions to this rule are:

The **RED-LINE** setting is good for use in any configuration as it helps control dynamic peaks and limit distortion at higher output levels.

The **CONTOUR** setting is also another good all around use setting and when used in Full Range or High Pass configurations tends to enhance the vocal and top end of the music. Great for helping to cover up interior noise.

The **ATTACK** setting is really geared for bass and midbass duty.

The possibilities are almost endless! *Tweak away!*

PERFORMANCE

Model	SX400.2	SX500.2	SX600.2	SX900.2
RMS Power In Watts, All Channels Driven				
@ 13.8V, 4Ω Stereo, 0.02% THD	88 x 2	113 x 2	138 x 2	213 x 2
@ 13.8V, 2Ω Stereo, 0.2% THD	175 x 2	225 x 2	275 x 2	425 x 2
@ 13.8V, 4Ω Mono, 0.4% THD	350 x 1	450 x 1	550 x 1	850 x 1
Dynamic Power In Watts, All Channels Driven				
@ 14.4V, 4Ω Stereo, 1% THD	100 x 2	125 x 2	150 x 2	225 x 2
@ 14.4V, 2Ω Stereo, 1% THD	200 x 2	250 x 2	300 x 2	450 x 2
@ 14.4V, 4Ω Mono, 1% THD	400 x 1	500 x 1	600 x 1	900 x 1
Length With EndKaps	16" (40.64cm)	19.25" (48.90cm)	22.5" (57.15cm)	25.75" (65.41cm)
Fusing	25A x 2	30A x 2	40A x 2	40A x 3
Recommended Power & Ground Wire	4 GA	4 GA	4 GA	2 GA

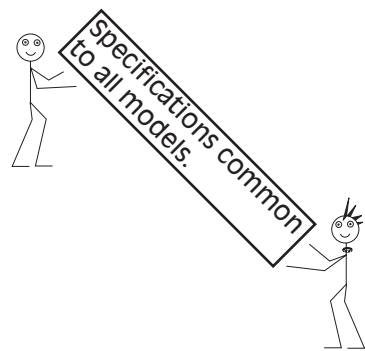

Height:	2.5 inches / 6.35 centimeters
Width:	10 inches / 25.4 centimeters
Length Without EndKaps:	Subtract 5 inches (12.7 cm) from chart above
Frequency Response:	20 Hz - 20 kHz, +0 / -1 dB
Input Sensitivity:	62.5 mV - 16 V
Signal-to-Noise Ratio:	> 100 dB
High Pass Crossover Freq.:	10 Hz - 16 kHz in 1/12 Octave steps
High Pass Crossover Slope:	0 (off) - 36 dB in 6 dB steps
Low Pass Crossover Freq.:	30 Hz - 20 kHz in 1/12 Octave steps
Low Pass Crossover Slope:	0 (off) - 36 dB in 6 dB steps
KicKEQ Frequency:	20 Hz - 20 kHz in 1/12 Octave steps
KicKEQ Bandwidth (Q):	.5 to 10 in .5 steps
KicKEQ Boost/Cut:	+/- 18 dB per Octave
Remote Bass Level Control:	Included with each amplifier
Power & Ground Terminals:	Will accept up to 2 Gauge wire
DSP Reaction Time / Delay:	.7 milliseconds (In other Words...Real Fast!)
Friend's Reaction:	That Shizzle's Off The Hizzle
Stranger's Reaction:	Dude...Sweet...

ELECTRONICS LIMITED WARRANTY

Kicker warrants this product to be free from defects in material and workmanship under normal use for a period of **90 DAYS** from date of original purchase with receipt. When purchased from an Authorized KICKER Dealer it is warranted for **TWO (2) YEARS** from date of original purchase with receipt. If the product is labeled "**B Stock**" it is warranted for **90 DAYS** from date of original purchase with receipt. If labeled "**B Stock**" and purchased from an Authorized KICKER Dealer, it is warranted for **ONE (1) YEAR** from date of purchase with receipt. In all cases you **must have** the **original receipt!** Should service be necessary under this warranty for any reason due to manufacturing defect or malfunction during the warranty period, Kicker will replace or repair (at its discretion) the defective merchandise with equivalent merchandise at no charge. Warranty replacements on "B-Stock" merchandise may have cosmetic scratches and blemishes. Discontinued products may be replaced with more current equivalent products.

This warranty is valid only for the **original purchaser** and is not extended to owners of the product subsequent to the original purchaser. Any applicable implied warranties are limited in duration to a period of the express warranty as provided herein beginning with the date of the original purchase at retail, and no warranties, whether express or implied, shall apply to this product thereafter. Some states do not allow limitations on implied warranties, therefore these exclusions may not apply to you.

This warranty gives you specific legal rights; however you may have other rights that vary from state to state.

WHAT TO DO IF YOU NEED WARRANTY OR SERVICE

Defective merchandise must be returned to your local Authorized Stillwater Designs (Kicker) Dealer for warranty. Assistance in locating an Authorized Dealer can be obtained by writing or calling Stillwater Designs direct. You can confirm that a dealer is authorized by asking to see a current authorized dealer window decal.

If it becomes necessary for you to return defective merchandise, call the Kicker Customer Service Department at (405)624-8510 for a Return Authorization (RMA) number. Package all defective items in the original container or in a package that will prevent shipping damage, and return to

Stillwater Designs, 5021 North Perkins Road, Stillwater, OK 74075

The RMA number must be clearly marked on the outside of the package. Return only defective components. Return of entire cabinets, system packs, pairs, etc. increases your return freight charges. Non-defective items received will be returned freight collect.

Include a dated **proof-of-purchase** stating the Customer name, Dealer name, product purchased and date of purchase. Warranty expiration on items without proof-of-purchase will be determined from type of sale and the manufacturing date code. Freight must be prepaid; items received freight collect will be refused.

Failure to follow these steps may void your warranty. Any questions can be directed to the Kicker Customer Service Department at (405)624-8510.

WHAT IS NOT COVERED?

This warranty is valid only if the product is used for the purpose for which it was designed.

It does not cover:

- Damage due to improper installation.
- Subsequent damage to other components.
- Damage caused by exposure to moisture, excessive heat, chemical cleaners, and/or UV radiation.
- Damage through negligence, misuse, accident or abuse. Repeated returns for the same damage may be considered abuse.
- Any cost or expense related to the removal or reinstallation of product.
- Speakers damaged due to amplifier clipping or distortion.
- Items previously repaired or modified by any unauthorized repair facility.
- Return shipping on non-defective items.
- Products with tampered or missing barcode labels.
- Products returned without a Return Authorization (RMA) number.
- Freight Damage.
- The cost of shipping product to Kicker.
- Service performed by anyone other than Kicker.
- Speaker with any foreign caulk used for gasket material.

HOW LONG WILL IT TAKE?

Kicker strives to maintain a goal of 24-hour service for all returns. Delays may be incurred if lack of replacement inventory or parts is encountered.

INTERNATIONAL WARRANTY

Contact your international Kicker dealer or distributor concerning specific procedures for your country's warranty policies.



STILLWATER
Designs®

P.O. Box 459 • Stillwater, Oklahoma 74076 • U.S.A. • 405 624-8510

WARNING:

KICKER drivers are capable of producing sound levels that can permanently damage your hearing! Turning up a system to a level that has audible distortion is more damaging to your ears than listening to an undistorted system at the same volume level. The threshold of pain is always an indicator that the sound level is too loud and may permanently damage your hearing. Please use common sense when controlling volume!

NOTES

NOTES

PIZZA DELIVERY

NOTES

CHIC'S NUMBERS



HOOK UPS

