



Maintenance and Service Guide

HP Notebook Expansion Base

Document Part Number: 344524-001

January 2004

This guide is a troubleshooting reference used for maintaining and servicing the HP Notebook Expansion Base. It provides comprehensive information on identifying Expansion Base features, components, and spare parts; troubleshooting problems; and performing disassembly procedures.

© Copyright 2004 Hewlett-Packard Development Company, L.P.

The information contained herein is subject to change without notice. The only warranties for HP products and services are set forth in the express warranty statements accompanying such products and services. Nothing herein should be construed as constituting an additional warranty. HP shall not be liable for technical or editorial errors or omissions contained herein.

Maintenance and Service Guide

HP Notebook Expansion Base

First Edition January 2004

Document Part Number: 344524-001

Contents

1 Product Description

- 1.1 Features 1-2
- 1.2 External Components 1-3
- 1.3 Wireless Accessories 1-9
- 1.4 Design Overview 1-10

2 Troubleshooting

- Before Replacing Parts 2-1
- Problems and Solutions 2-2

3 Illustrated Parts Catalog

- 3.1 Serial Number Location 3-1
- 3.2 HP Notebook Expansion Base
Major Components 3-2

4 Removal and Replacement Preliminaries

- 4.1 Tools Required 4-1
- 4.2 Service Considerations 4-1
 - Plastic Parts 4-2
 - Cables and Connectors 4-2
- 4.3 Preventing Electrostatic Damage 4-2
- 4.4 Packaging and Transporting Precautions 4-3
- 4.5 Workstation Precautions 4-4
- 4.6 Grounding Equipment and Methods 4-5

5 Removal and Replacement Procedures

5.1 Serial Number	5-2
5.2 Disassembly Sequence Chart	5-3
5.3 Preparing the HP Notebook Expansion Base for Disassembly	5-4
5.4 Base Plate	5-5
5.5 Upper Chassis	5-6
5.6 Power Supply	5-10
5.7 System Board	5-12
5.8 Front Tray Cover	5-14
5.9 Back Panel	5-16
5.10 Expansion Cable	5-17
5.11 Speaker Assembly	5-18
5.12 Front Case	5-20

6 Specifications

A Connector Pin Assignments

B Power Cord Set Requirements

3-Conductor Power Cord Set	B-1
General Requirements	B-1
Country-Specific Requirements	B-2

C Screw Listing

Index

Product Description

The HP Notebook Expansion Base expands the connectivity of HP Compaq Business Notebook nx9100 Series; HP Pavilion zd7000, zv5000, and zx5000 Series notebook PCs; and the Compaq Presario R3000 Series notebook PC. The Expansion Base provides an efficient, less-cluttered work environment, improved cable management, and wireless peripherals. It eliminates the need to purchase a separate monitor, external speakers, USB hub, and a wireless keyboard and mouse kit.



HP Notebook Expansion Base

1.1 Features

- AC power (charges attached notebook while docked)
- Supports panel sizes up to 17" wide
- Altec Lansing speakers
- Wireless keyboard
- Wireless mouse
- Wireless keyboard/mouse receiver
- Security slots
- Connectors:
 - Expansion cable
 - S/PDIF (Sony/Philips Digital Interface) audio connector
 - Audio out/Headphone jack
 - Composite out
 - RJ-11 (modem) connection (from wall to Expansion Base)
 - RJ-11 (modem) connection (from Expansion Base to notebook)
 - RJ-45/Ethernet port
 - Six Universal Serial Bus (USB) 2.0 connectors
 - S-Video out
 - Serial port

1.2 External Components

The external components on the front panel of the Expansion Base are shown below and described in Table 1-2.

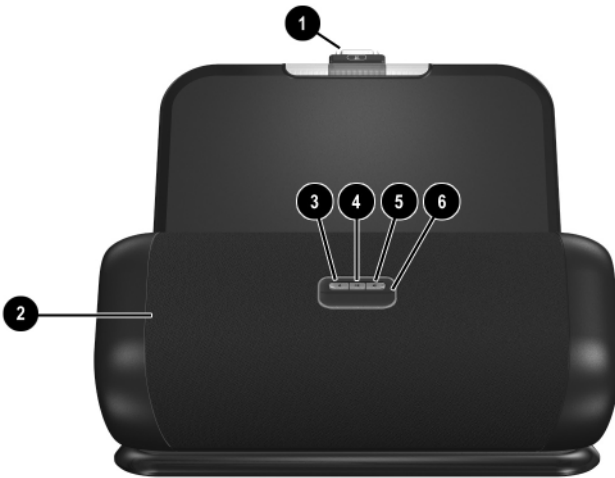

Front components

Table 1-2
Front Components



Item	Component	Function
1	Expansion cable	Connects the HP Notebook Expansion Base to the notebook computer.
2	Stereo speaker assembly	Produces stereo sound from the notebook.
3	Volume down button	Lowers system volume.
4	Mute button	Mutes or restores volume.
5	Volume up button	Increases system volume.
6	Connection indicator light	Glows solid blue when the notebook is connected correctly.

The external components on the right side of the Expansion Base are shown below and described in Table 1-3 .



Right-side components

**Table 1-3
Right-Side Components**

Item	Component	Function
1	Audio out/Headphone jack	Connects optional headphone or powered stereo speakers.
2	USB connectors (3)	Connect optional USB 2.0 devices.
3	Vent	Allows airflow to cool internal components.  To prevent overheating, do not obstruct the vents.
4	Kensington security cable slot	Connects an optional security cable.  The purpose of security solutions is to act as a deterrent. These solutions do not prevent the product from being mishandled or stolen.

The external components on the rear of the Expansion Base are shown below and described in Table 1-4.

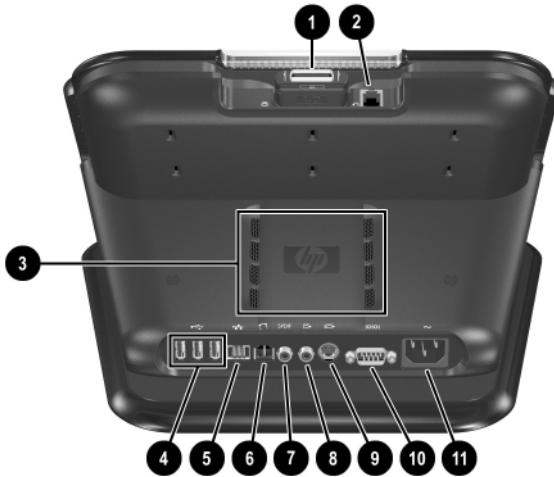

Rear components

Table 1-4
Rear Panel Components



Item	Component	Function
1	Expansion cable	Connects the Expansion Base to a notebook computer.
2	RJ-11 jack	Connects a modem cable from the Expansion Base to a notebook.
3	Vents (2)	Allow airflow to cool internal components.  To prevent overheating, do not obstruct the vents.
4	USB connectors (3)	Connect optional USB 2.0 devices
5	RJ-45 network jack	Connects an Ethernet network cable from the Expansion Base to an RJ-45 wall jack.
6	RJ-11 jack	Connects the Expansion Base to an RJ-11 telephone wall jack.
7	S/PDIF (Sony/Philips Digital Interface) audio connector	Connects high-end digital systems, such as surround sound or a home theatre.
8	TV out/Composite jack	Connects a television, VCR, camcorder, or projector.
9	TV out/ S-Video jack	Connects an optional S-Video device, such as a television, VCR, camcorder, projector, or video capture card.
10	Serial connector	Connects a serial device, such as a mouse.
11	Power connector	Connects AC power cord. Charges notebook while docked.

The external components on the left side of the Expansion Base are shown below and described in Table 1-5.



Left-Side Components

**Table 1-5
Left-Side Components**

Item	Component	Function
1	Kensington security cable slot	Connects an optional security cable.  The purpose of security solutions is to act as a deterrent. These solutions do not prevent the product from being mishandled or stolen.
2	Vent	Allows airflow to cool internal components.  To prevent overheating, do not obstruct the vents.

1.3 Wireless Accessories



Table 1-6
Wireless Accessories

Item	Component	Function
1	Wireless keyboard	Connects to the Expansion Base without a cable.
2	Receiver	Connects to a USB port on the Expansion Base. Allows connection between the Expansion Base and the wireless keyboard and mouse.
3	Wireless mouse	Connects to the Expansion Base without a cable.

1.4 Design Overview

This section presents a design overview of key parts and features of the HP Notebook Expansion Base. Refer to [Chapter 3, “Illustrated Parts Catalog,”](#) to identify replacement parts, and [Chapter 5, “Removal and Replacement Procedures,”](#) for disassembly steps.

The Expansion Base provides the following device connections:

- Expansion cable
- S/PDIF (Sony/Philips Digital Interface) audio connector
- Audio out/Headphone jack
- Composite out
- RJ-11 (modem) connection (from wall to Expansion Base)
- RJ-11 (modem) connection (from Expansion Base to notebook)
- RJ-45/Ethernet port
- Six USB 2.0 connectors
- S-Video out
- Serial port

The HP Notebook Expansion Base uses electrical fans for ventilation. The fans are controlled by a temperature sensor and are designed to turn on automatically when high temperature conditions exist. These conditions are affected by high external temperatures, system power consumption, power management/battery conservation configurations, and software applications. Exhaust air is displaced through the ventilation grill located on the right side, left side, and rear panel of the unit.



CAUTION: To properly ventilate the HP Notebook Expansion Base, allow at least a 7.6-cm (3-inch) clearance on the left and right sides of the unit.

Troubleshooting



WARNING: Only authorized technicians trained by HP should repair this equipment. All troubleshooting and repair procedures are detailed to allow only subassembly/module level repair. Because of the complexity of the individual boards and subassemblies, do not attempt to make repairs at the component level or modifications to any printed wiring board. Improper repairs can create a safety hazard. Any indication of component replacement or printed wiring board modification may void any warranty or exchange allowances.

This chapter contains troubleshooting information for the HP Notebook Expansion Base. Carefully match the symptoms of the malfunction against the problem description in the Troubleshooting tables to avoid a misdiagnosis. Refer to [Chapter 5](#) for all removal and replacement procedures.

Follow these guidelines when troubleshooting:

- Complete the recommended actions in the order in which they are given.
- When the problem is resolved, do not complete the remaining troubleshooting steps.

Before Replacing Parts

When troubleshooting a problem, check the following list for possible solutions before replacing parts:

- Verify that cables are connected properly to the suspected defective part.
- Verify that all required device drivers are installed on the notebook.

Problems and Solutions

The following tables list possible problems, the possible cause of each problem, and the recommended solution.

Table 2-1
Power Problems and Solutions

Problem	Possible Cause	Solution
The blue indicator light does not come on.	The notebook is not powered on.	Turn on the notebook.
	The Expansion Base is not connected to AC power.	Verify that the AC cable is properly connected to the Expansion Base and to an AC power outlet.
	The expansion cable on the Expansion Base is not properly connected to the expansion connector on the notebook.	Turn off the notebook and unplug the expansion cable. Then plug the expansion cable back in to the notebook and turn the notebook on.
	If the above solutions are unsuccessful, the expansion cable may be damaged.	Replace the expansion cable. (Section 5.10)
	If the above solutions are unsuccessful, the power supply may be malfunctioning.	Replace the power supply. (Section 5.6)
The notebook shuts down.	The Expansion Base is not plugged into an AC power outlet, draining the notebook battery pack.	Plug the Expansion Base into an AC power outlet.
	If the above solution is unsuccessful, the power supply may be malfunctioning.	Replace the power supply. (Section 5.6)

Table 2-2
External Device Problems and Solutions

Problem	Possible Cause	Solution
A new device is not recognized as part of the notebook system.	The device cable or power cord is loose.	<ul style="list-style-type: none"> ■ Test the device first by plugging it into the appropriate notebook connector. Note that composite TV out and serial connectors are not supported on the notebook. ■ Ensure that all cables are securely connected to the device and the Expansion Base. ■ Ensure that all power cords are securely connected to the device and to an electrical outlet.
	Device cabling is incorrect.	Ensure that the device cable is in the correct connector on the Expansion Base.
	The device was connected while the system was on.	Turn off the notebook, turn on the device (if applicable), and then turn on the notebook.
	Device drivers may need to be installed on the notebook.	Install drivers according to the device manufacturer's instructions.
	If the above solutions are unsuccessful, the system board may be malfunctioning.	Replace the system board. (Section 5.7)

Illustrated Parts Catalog

This chapter provides an illustrated parts breakdown and a reference for spare part numbers and option part numbers.

3.1 Serial Number Location

When ordering parts or requesting information, provide the Expansion Base serial number and model number located on the bottom of the base plate.



Serial number location

3.2 HP Notebook Expansion Base Major Components



HP Notebook Expansion Base major components

Table 3-1
Spare Parts: HP Notebook Expansion Base
Major Components

Item	Description	Spare Part Number
1	Back panel (with modem connector and cable)	347433-001
2	Upper chassis	347434-001
3	Expansion cable	347435-001
4	Speaker assembly	347431-001
5	Front tray cover	347432-001
	Miscellaneous Plastics Kit (including the following components)	347436-001
6	Front case	
7a	Rear cover	
7b	Base enclosure	
7c	Base plate	
8	Power supply and shield	347438-001
9	System board	347437-001



HP Notebook Expansion Base miscellaneous components

Table 3-1
Spare Parts: HP Notebook Expansion Base Miscellaneous Components

Item	Description	Spare Part Number
1	Receiver	348088-001
2	Wireless mouse	348087-001
3	Wireless keyboard	
	ADP	348086-371 Latin America 348086-161
	Australia	348086-011 The Netherlands 348086-331
	Brazil	348086-201 Norway 348086-091
	Canada (Fr.)	348086-121 Poland 348086-241
	Czech Rep.	348086-221 Portugal 348086-131
	Denmark	348086-081 Peoples Republic of
	Europe	348086-021 China 348086-AA1
	France	348086-051 Russia 348086-251
	Germany	348086-041 Saudi Arabia 348086-171
	Greece	348086-151 Sweden/Finland 348086-B71
	Hong Kong	348086-DC1 Slovenia 348086-BA1
	Hungary	348086-211 Spain 348086-071
	India	348086-D61 Thailand 348086-281
	Iceland	348086-DD1 Turkey 348086-141
	Israel	348086-BB1 Taiwan 348086-AB1
	Italy	348086-061 United Kingdom 348086-031
	Japan	348086-291 United States 348086-001
	Korea	348086-AD1

Table 3-2
Spare Parts: HP Notebook Expansion Base
Miscellaneous Components (not illustrated)

Item	Description	Spare Part Number
	Power cord	
	Australia	345252-011
	Brazil	345252-201
	Denmark	345252-081
	Europe	345252-021
	French Canada	345252-121
	Israel	345252-BB1
	India	345252-D61
	Italy	345252-061
	Japan	345252-291
	Korea	345252-AD1
	China	345252-AA1
	Switzerland	345252-111
	United Kingdom	345252-031
	United States	345252-001

Removal and Replacement Preliminaries

This chapter provides essential information for proper and safe removal and replacement service.

4.1 Tools Required

You will need the following tools to complete the removal and replacement procedures:

- Magnetic screwdriver
- Phillips P0 screwdriver
- 5.0-mm hex socket for system board standoff
- Flat-bladed screwdriver
- Tool kit (includes connector removal tool, loopback plugs, and case utility tool)

4.2 Service Considerations

The following sections include some of the considerations that you should keep in mind during disassembly and assembly procedures.



As you remove each subassembly from the Expansion Base, place the subassembly (and all accompanying screws) away from the work area to prevent damage.

Plastic Parts

Using excessive force during disassembly and reassembly can damage plastic parts. Use care when handling the plastic parts. Apply pressure only at the points designated in the maintenance instructions.

Cables and Connectors

Cables must be handled with extreme care to avoid damage. Apply only the tension required to unseat or seat the cables during removal and insertion. Handle cables by the connector whenever possible. In all cases, avoid bending, twisting, or tearing cables. Ensure that cables are routed in such a way that they cannot be caught or snagged by parts being removed or replaced. Handle flex cables with extreme care; these cables tear easily.



CAUTION: When servicing the Expansion Base, ensure that cables are placed in their proper locations during the reassembly process. Improper cable placement can damage the Expansion Base.

4.3 Preventing Electrostatic Damage

Many electronic components are sensitive to electrostatic discharge (ESD). Circuitry design and structure determine the degree of sensitivity. Networks built into many integrated circuits provide some protection, but in many cases, the discharge contains enough power to alter device parameters or melt silicon junctions.

A sudden discharge of static electricity from a finger or other conductor can destroy static-sensitive devices or microcircuitry. Often the spark is neither felt nor heard, but damage occurs.

An electronic device exposed to electrostatic discharge might not be affected at all and can work perfectly throughout a normal cycle. Or the device might function normally for a while, and then degrade in the internal layers, reducing its life expectancy.

4.4 Packaging and Transporting Precautions

Use the following grounding precautions when packaging and transporting equipment:

- To avoid hand contact, transport products in static-safe containers, such as tubes, bags, or boxes.
- Protect all electrostatic-sensitive parts and assemblies with conductive or approved containers or packaging.
- Keep electrostatic-sensitive parts in their containers until the parts arrive at static-free workstations.
- Place items on a grounded surface before removing items from their containers.
- Always be properly grounded when touching a sensitive component or assembly.
- Store reusable electrostatic-sensitive parts from assemblies in protective packaging or nonconductive foam.
- Use transporters and conveyors made of antistatic belts and roller bushings. Ensure that mechanized equipment used for moving materials is wired to ground and that proper materials are selected to avoid static charging. When grounding is not possible, use an ionizer to dissipate electric charges.

4.5 Workstation Precautions

Use the following grounding precautions at workstations:

- Cover the workstation with approved static-shielding material (refer to [Table 4-2, Static-Shielding Materials](#)).
- Use a wrist strap connected to a properly grounded work surface and use properly grounded tools and equipment.
- Use conductive field service tools, such as cutters, screwdrivers, and vacuums.
- When using fixtures that must directly contact dissipative surfaces, only use fixtures made of static-safe materials.
- Keep the work area free of nonconductive materials, such as ordinary plastic assembly aids and Styrofoam.
- Handle electrostatic-sensitive components, parts, and assemblies by the case or PCM laminate. Handle these items only at static-free workstations.
- Avoid contact with pins, leads, or circuitry.
- Turn off power and input signals before inserting or removing connectors or test equipment.

4.6 Grounding Equipment and Methods

Grounding equipment must include either a wrist strap or a foot strap at a grounded workstation.

- When seated, wear a wrist strap connected to a grounded system. Wrist straps are flexible straps with a minimum of one megohm $\pm 10\%$ resistance in the ground cords. To provide proper ground, wear a strap snugly against the skin at all times. On grounded mats with banana-plug connectors, use alligator clips to connect a wrist strap.
- When standing, use foot straps and a grounded floor mat. Foot straps (heel, toe, or boot straps) can be used at standing workstations and are compatible with most types of shoes or boots. On conductive floors or dissipative floor mats, use foot straps on both feet with a minimum of one megohm resistance between the operator and ground. To be effective, the conductive strips must be worn in contact with the skin.

Other grounding equipment recommended for use in preventing electrostatic damage includes:

- Antistatic tape
- Antistatic smocks, aprons, and sleeve protectors
- Conductive bins and other assembly or soldering aids
- Nonconductive foam
- Conductive tabletop workstations with ground cords of one megohm resistance
- Static-dissipative tables or floor mats with hard ties to the ground
- Field service kits
- Static awareness labels

- Material-handling packages
- Nonconductive plastic bags, tubes, or boxes
- Metal tote boxes
- Electrostatic voltage levels and protective materials

Table 4-1 shows how humidity affects the electrostatic voltage levels generated by different activities.

**Table 4-1
Typical Electrostatic Voltage Levels**

Event	Relative Humidity		
	10%	40%	55%
Walking across carpet	35,000 V	15,000 V	7,500 V
Walking across vinyl floor	12,000 V	5,000 V	3,000 V
Motions of bench worker	6,000 V	800 V	400 V
Removing DIPS from plastic tube	2,000 V	700 V	400 V
Removing DIPS from vinyl tray	11,500 V	4,000 V	2,000 V
Removing DIPS from Styrofoam	14,500 V	5,000 V	3,500 V
Removing bubble pack from PCB	26,500 V	20,000 V	7,000 V
Packing PCBs in foam-lined box	21,000 V	11,000 V	5,000 V

 A product can be degraded by as little as 700 V.

Table 4-2 lists the shielding protection provided by antistatic bags and floor mats.

**Table 4-2
Static-Shielding Materials**

Material	Use	Voltage Protection Level
Antistatic plastic	Bags	1,500 V
Carbon-loaded plastic	Floor mats	7,500 V
Metallized laminate	Floor mats	5,000 V

5

Removal and Replacement Procedures

This chapter provides removal and replacement procedures.

There are 37 screws and standoffs, in six different sizes, that must be removed, replaced, and loosened when servicing the Expansion Base. Make special note of each screw size and location during removal and replacement.

Refer to [Appendix C, “Screw Listing,”](#) for detailed information on screw sizes, locations, and usage.

5.1 Serial Number

Report the Expansion Base serial number to HP when requesting information or ordering spare parts. The serial number is located on the bottom of the Expansion Base.



Serial number location

5.2 Disassembly Sequence Chart

Use the chart below to determine the section number to be referenced when removing Expansion Base components.

Disassembly Sequence Chart

Section	Description	# of Screws Removed
5.3	Preparing the Expansion Base for disassembly	
5.4	Base plate	4
5.5	Upper chassis	2
5.6	Power supply	5
5.7	System board	5
5.8	Front tray cover	4
5.9	Back panel	4
5.10	Expansion cable	4
5.11	Speaker assembly	2
5.12	Front case	6

5.3 Preparing the HP Notebook Expansion Base for Disassembly

Perform the following steps before disassembling the Expansion Base:

1. If the notebook computer is in the Expansion Base, turn off the notebook and press the buttons on the end of the expansion cable **1** to disconnect the cable from the notebook **2**.
2. Disconnect the AC adapter and all external devices.



The location of the expansion connector on the notebook may vary by notebook series and model.

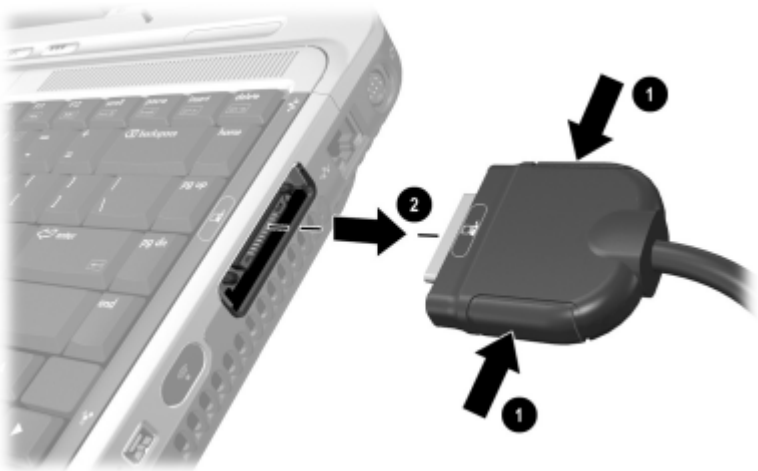

Disconnecting the expansion cable

5.4 Base Plate

Spare Part Number Information

Base plate	The base plate is included in the Miscellaneous Plastics Kit	347436-001
-------------------	--	------------

1. Turn the Expansion Base upside down with the front facing away from you.
2. Remove the four PM2.5×17.0 screws ❶ that secure the base plate to the base enclosure.
3. Remove the base plate ❷.

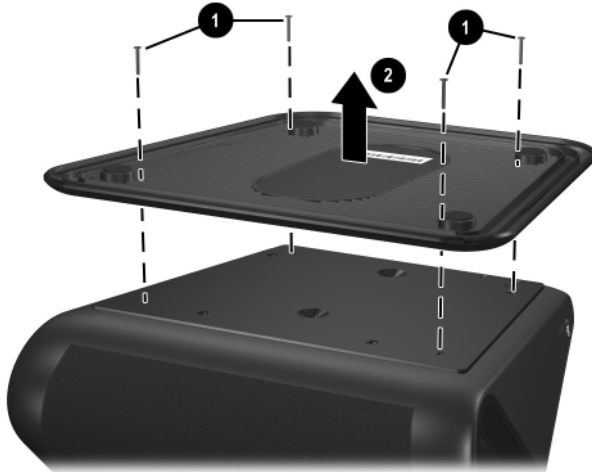

Removing the base plate

Reverse the above procedure to install the base plate.

5.5 Upper Chassis

1. Prepare the Expansion Base for disassembly ([Section 5.3](#)).
2. Remove the base plate ([Section 5.4](#)).
3. Turn the Expansion Base right-side up with the rear panel facing you.
4. Remove the adhesive-backed 8.0-mm diameter screw covers **1**.
5. Remove the two PM2.0×6.0 screws **2** that secure the rear cover to the base enclosure.

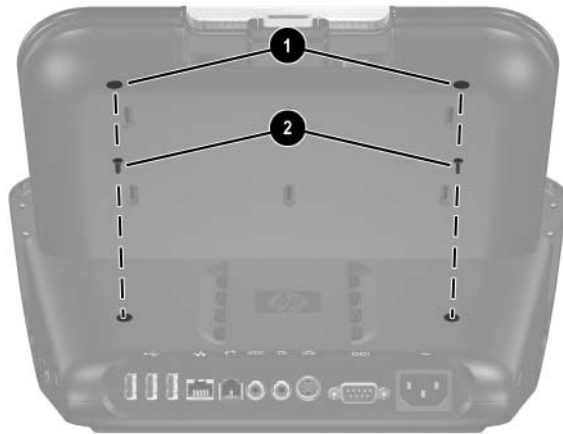

Removing the rear cover screws

6. Lift the front edge of the rear cover up **1** until it disengages from the base enclosure.
7. Slide the rear cover toward you **2** and remove it.

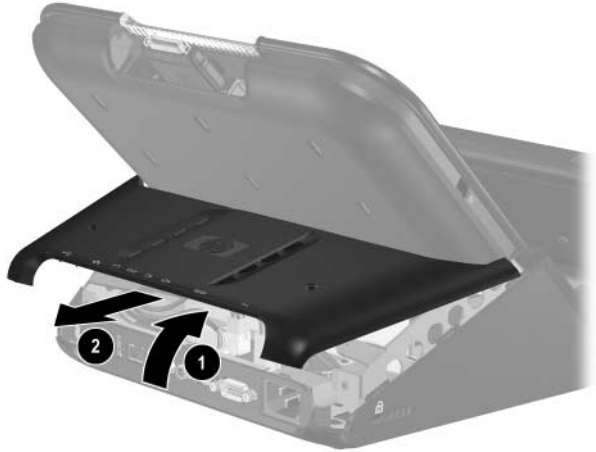

Removing the rear cover

8. Disconnect the following cables from the system board:

- ❶ 4-wire cable
- ❷ 2-wire RJ-11 modem cable
- ❸ 50-pin cable
- ❹ 6-wire cable
- ❺ 4-wire power cable

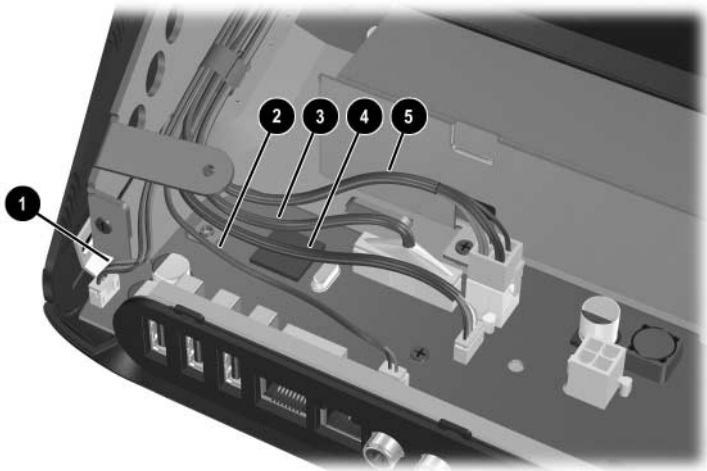

Disconnecting the cables from the system board

9. Remove the two PM2.0×4.0 screws ❶ that secure the upper chassis to the base enclosure.
10. Swing the top edge of the upper chassis upward ❷ to disengage it from the base enclosure.
11. Lift the upper chassis straight up ❸ and remove it.

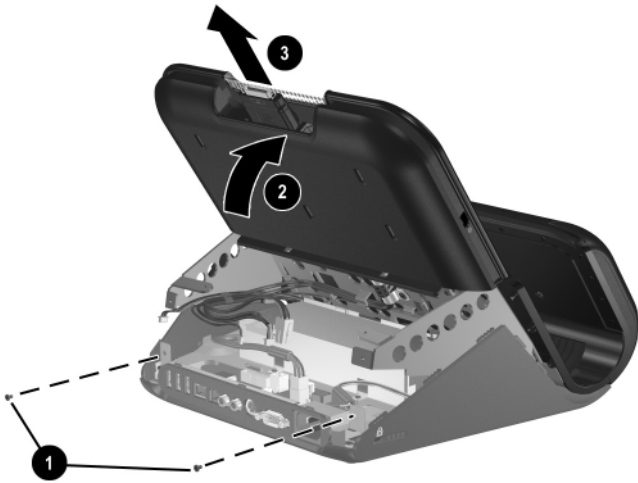

Removing the upper chassis

Reverse the above procedure to install the upper chassis.

5.6 Power Supply

Spare Part Number Information

Power supply

347438-001

1. Prepare the Expansion Base for disassembly ([Section 5.3](#)).
2. Remove the base plate ([Section 5.4](#)).
3. Remove the upper chassis ([Section 5.5](#)).
4. Turn the base enclosure upside down with the front facing you.
5. While holding the power supply in place with one hand underneath, remove the five PM2.0×6.0 screws that secure the power supply to the base enclosure.

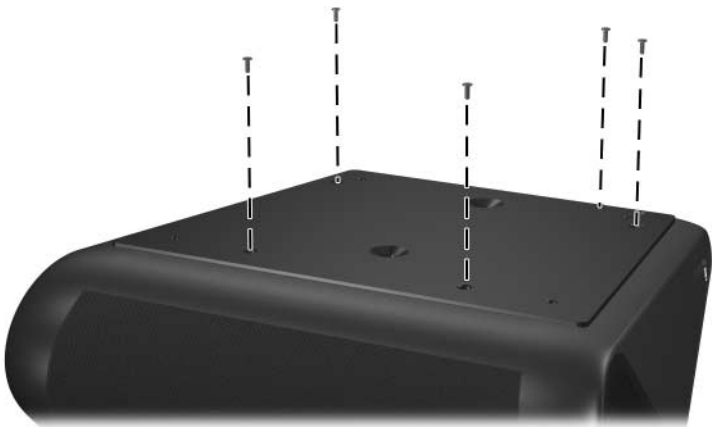

Removing the power supply screws

6. Turn the base enclosure right-side up with the rear facing you.
7. On the base enclosure, disconnect the power supply cable ❶ from the system board.
8. Lift the power supply and shield approximately one inch ❷.
9. While holding the power supply and shield, remove the power connector ❸ from the supports in the base enclosure.

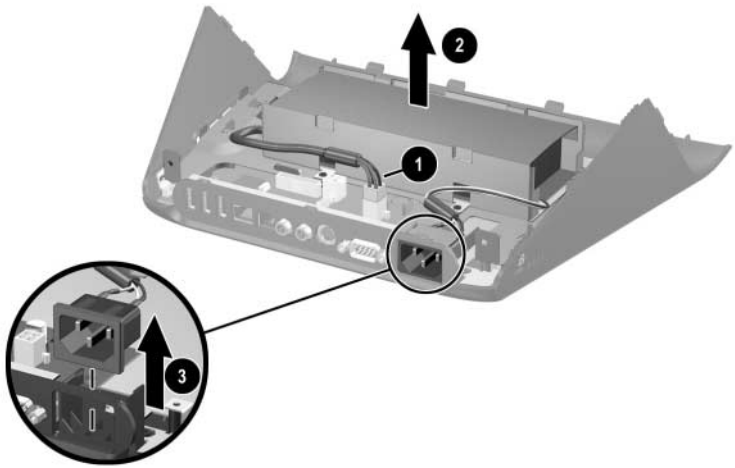

Removing the power supply

Reverse the above procedure to install the power supply.

5.7 System Board

Spare Part Number Information

System board

347437-001

1. Prepare the Expansion Base for disassembly ([Section 5.3](#)).
2. Remove the base plate ([Section 5.4](#)).
3. Remove the upper chassis ([Section 5.5](#)).
4. Remove the power supply ([Section 5.6](#)).
5. Position the base enclosure with the rear panel facing you.
6. Remove the three PM2.0×6.0 screws ❶ that secure the system board to the base enclosure.
7. Use a 5.0-mm hex socket to remove the two HM5.0×9.0 standoffs ❷ on either side of the serial connector.

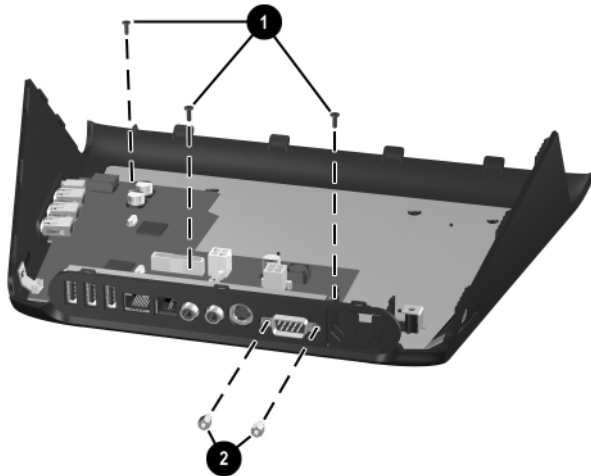

Removing the system board screws and standoffs

8. Swing the top left edge of the system board clockwise ① until the audio connector ② disengages from the hole ③ in the base enclosure.
9. Remove the system board from the base enclosure ④.

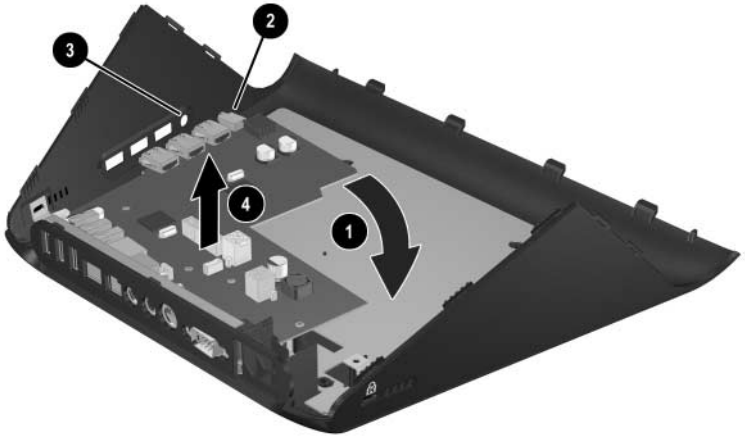

Removing the system board

Reverse the above procedure to install the system board.

5.8 Front Tray Cover

Spare Part Number Information

Front tray cover

347432-001

1. Prepare the Expansion Base for disassembly ([Section 5.3](#)).
2. Remove the base plate ([Section 5.4](#)).
3. Remove the upper chassis ([Section 5.5](#)).
4. Turn the upper chassis upside down with the docking connector and cable facing away from you.
5. Cut all tie-wraps **1** that bundle the Expansion Base cables and secure the RJ-11 modem cable to the chassis.
6. Remove the four PM2.0×4.0 screws **2** that secure the front tray cover to the chassis.

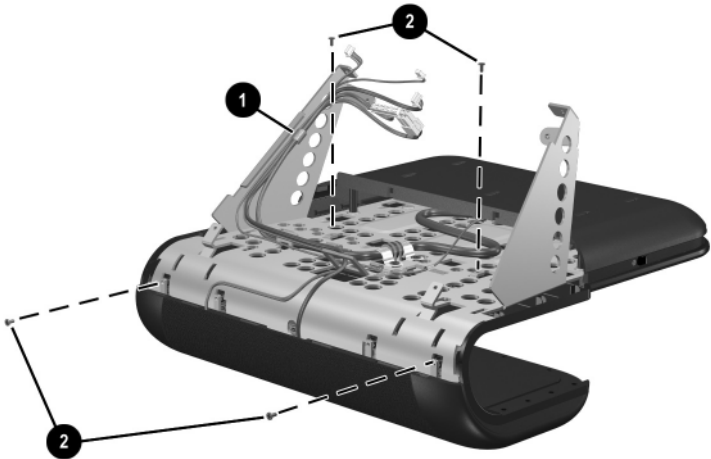

Removing the front tray cover screws

7. Turn the upper chassis right-side up with the expansion cable facing you.
8. Slide the front tray cover upward and then away from you to remove it.

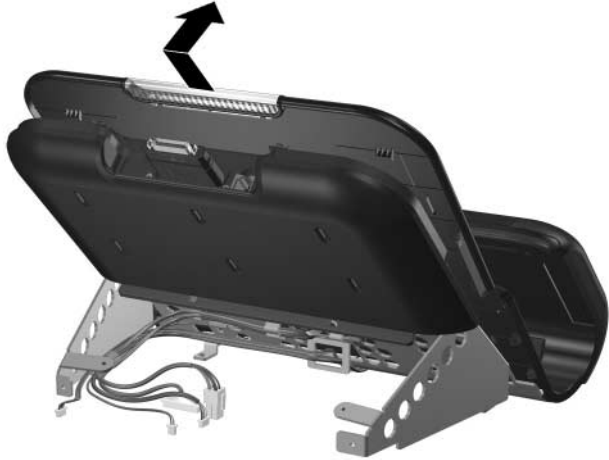

Removing the front tray cover

Reverse the above procedure to install the front tray cover.

5.9 Back Panel

Spare Part Number Information

Back panel with RJ-11 cable

347433-001

1. Prepare the Expansion Base for disassembly (Section 5.3).
2. Remove the base plate (Section 5.4).
3. Remove the upper chassis (Section 5.5).
4. Remove the front tray cover (Section 5.8).
5. Position the upper chassis right-side up with the speakers facing you.



Make sure that the back panel is supported before performing the following steps.

6. Remove the four PM2.0×4.0 screws ❶ that secure the back panel to the chassis.
7. Remove the back panel with the RJ-11 cable attached ❷.

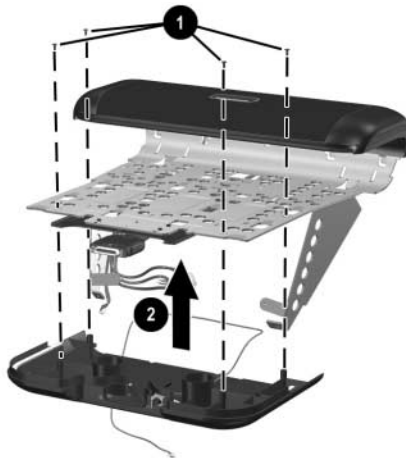

Removing the back panel

Reverse the above procedure to install the back panel.

5.10 Expansion Cable

Spare Part Number Information

Expansion cable347435-001

1. Prepare the Expansion Base for disassembly ([Section 5.3](#)).
2. Remove the base plate ([Section 5.4](#)).
3. Remove the upper chassis ([Section 5.5](#)).
4. Remove the front tray cover ([Section 5.8](#)).
5. Remove the back panel ([Section 5.9](#)).
6. Turn the upper chassis right-side up with the rear facing you. Rotate the chassis so that the expansion cable connector is facing away from you.
7. Remove the four PM2.0×2.0 screws **1** that secure the expansion cable clamps to the chassis.
8. Remove the expansion cable clamps **2** and the expansion cable **3**.

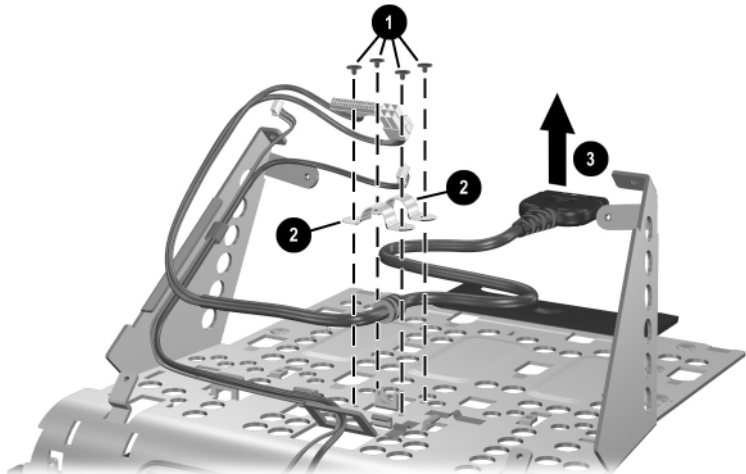

Removing the expansion cable clamps and expansion cable

Reverse the above procedure to install the expansion cable.

5.11 Speaker Assembly

Spare Part Number Information

Speaker assembly	347431-001
------------------	------------

1. Prepare the Expansion Base for disassembly (Section 5.3).
2. Remove the base plate (Section 5.4).
3. Remove the upper chassis (Section 5.5).
4. Remove the front tray cover (Section 5.8).



Although the back panel and expansion cable are not shown in the figure, it is not necessary to remove them.

5. Turn the upper chassis upside down, with the bottom facing you and the speaker assembly facing down.
6. Remove the 6-wire audio control cable ❶ and the 4-wire speaker cable ❷ from the chassis hole through which they are routed.
7. Remove the two PM2.0x4.0 screws ❸ that secure the speaker assembly to the chassis.

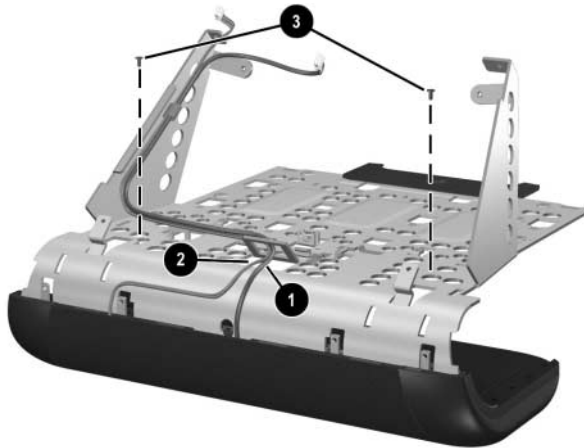

Removing the speaker assembly screws

8. Rotate the chassis 180 degrees toward you.
9. Slide the speaker assembly away from you ❶ to disengage it from the chassis.
10. Lift the edge of the speaker assembly to remove it from the chassis ❷.

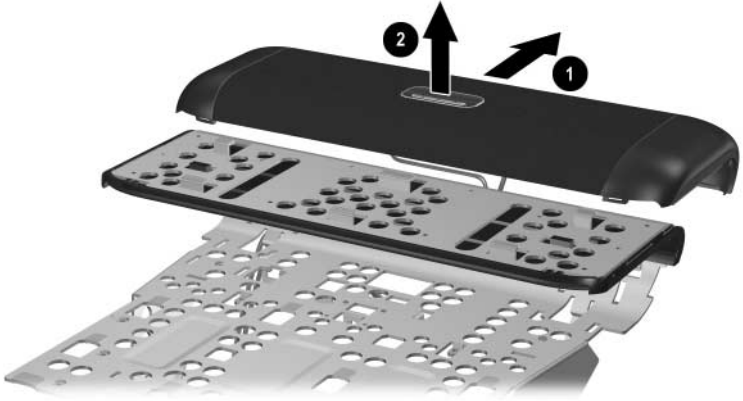

Removing the speaker assembly

Reverse the above procedure to install the speaker assembly.

5.12 Front Case

Spare Part Number Information

Front case (plastics kit)	347436-001
Upper chassis	347434-001

1. Prepare the Expansion Base for disassembly (Section 5.3).
2. Remove the base plate (Section 5.4).
3. Remove the upper chassis (Section 5.5).
4. Remove the front tray cover (Section 5.8).
5. Remove the speaker assembly (Section 5.11).
6. Turn the chassis right-side up with the rear facing you. Rotate the top of the chassis toward you.
7. Remove the six PM2.0×5.0 screws ❶ that secure the upper chassis front case to the chassis.
8. Slide the front case toward you ❷ to disengage it from the chassis.
9. Remove the front case ❸ from the chassis.

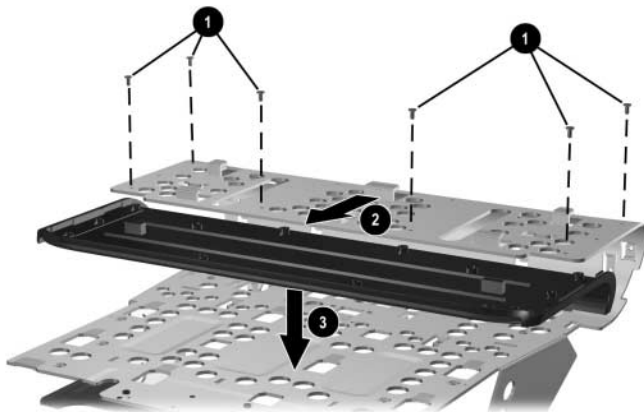

Removing the front case

Reverse the above procedure to install the front case.

Specifications

This chapter provides physical and performance specifications.

Table 6-1
HP Notebook Expansion Base

Dimensions		
Height	22.8 cm	9 in
Width	31.8 cm	12.5 in
Depth	29.8 cm	11.75 in
Weight		
	3.5 kg	7.5 lb
Stand-alone power requirements		
Power supply	18.5 V at 8 amps	
Temperature		
Operating (not writing optical)	0°C to 35°C	32°F to 95°F
Operating (writing optical)	5°C to 35°C	41°F to 95°F
Nonoperating	-20°C to 60°C	-4°F to 140°F
 Applicable product safety standards specify thermal limits for plastic surfaces. The notebook operates well within this range of temperatures.		
Relative humidity (noncondensing)		
Operating	10% to 90%	
Nonoperating	5% to 95%, 38.7°C (101.6°F) maximum wet bulb temperature	

Table 6-2
Internal AC Adapter

Power supply	160 W with PFC
Rated input voltage	100 to 240 VAC RMS
Rated input current	1.7 A RMS
Rated frequency	47 to 63 Hz

A

Connector Pin Assignments

Table A-1
RJ-45 Network Interface

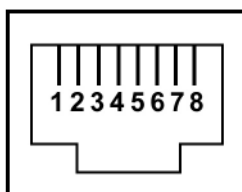

Pin	Signal	Pin	Signal
1	Transmit +	5	Unused
2	Transmit -	6	Receive -
3	Receive +	7	Unused
4	Unused	8	Unused

Table A-2
RJ-11 Modem

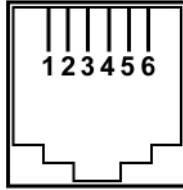

Pin	Signal	Pin	Signal
1	Unused	4	Unused
2	Tip	5	Unused
3	Ring	6	Unused

Table A-3
Universal Serial Bus

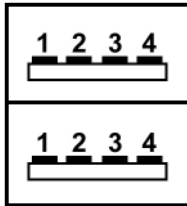

Pin	Signal	Pin	Signal
1	+5 VDC	3	Data +
2	Data -	4	Ground

**Table A-4
S-Video**

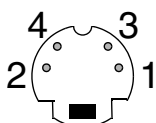

Pin	Signal	Pin	Signal
1	Ground (Y)	3	Y-Luminance (Intensity)
2	Ground (C)	4	C-Chrominance (Color)

**Table A-5
Audio Line-Out**

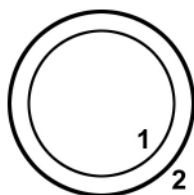

Pin	Signal	Pin	Signal
1	Audio out	2	Ground

Table A-6
Serial

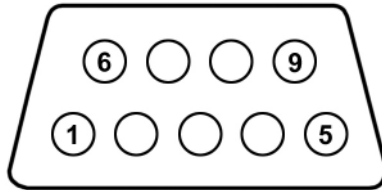

Pin	Signal	Pin	Signal
1	Carrier detect	6	Data set ready
2	Receive data	7	Ready to send
3	Transmit data	8	Clear to send
4	Data terminal ready	9	Ring indicator
5	Ground		

**Table A-7
S/PDIF Audio Line-Out**

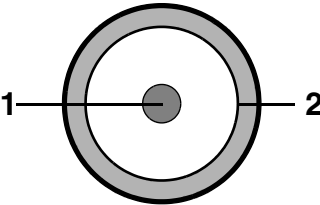

Pin	Signal	Pin	Signal
1	Audio signal	2	Ground/return

**Table A-8
Video**

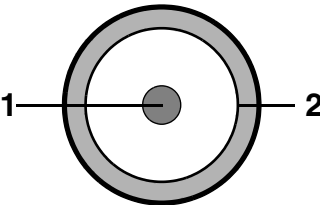

Pin	Signal	Pin	Signal
1	Video signal	2	Ground/return

Power Cord Set Requirements

3-Conductor Power Cord Set

The wide range input feature of the notebook permits it to operate from any line voltage from 100 to 120 or 220 to 240 volts AC.

The power cord set shipped with the notebook meets the requirements for use in the country where the equipment is purchased.

Power cord sets for use in other countries must meet the requirements of the country where the notebook is used.

General Requirements

The requirements listed below are applicable to all countries:

- The length of the power cord set must be at least 1.5 meters (5.00 feet) and a maximum of 2.0 meters (6.50 feet).
- All power cord sets must be approved by an acceptable accredited agency responsible for evaluation in the country where the power cord set will be used.
- The power cord set must have a minimum current capacity of 10 amps and a nominal voltage rating of 125 or 250 volts AC, as required by each country's power system.
- The appliance coupler must meet the mechanical configuration of an EN 60 320/IEC 320 Standard Sheet C13 connector for mating with the appliance inlet on the back of the notebook.

Country-Specific Requirements

3-Conductor Power Cord Set Requirements

Country	Accredited Agency	Applicable Note Number
Australia	EANSW	1
Austria	OVE	1
Belgium	CEBC	1
Canada	CSA	2
Denmark	DEMKO	1
Finland	FIMKO	1
France	UTE	1
Germany	VDE	1
Italy	IMQ	1
Japan	METI	3
The Netherlands	KEMA	1
Norway	NEMKO	1
Sweden	SEMKO	1
Switzerland	SEV	1

3-Conductor Power Cord Set Requirements (*Continued*)

Country	Accredited Agency	Applicable Note Number
United Kingdom	BSI	1
United States	UL	2

Notes

1. The flexible cord must be <HAR> Type HO5VV-F, 3-conductor, 1.0 mm² conductor size. Power cord set fittings (appliance coupler and wall plug) must bear the certification mark of the agency responsible for evaluation in the country where it will be used.
2. The flexible cord must be Type SPT-3 or equivalent, No. 18 AWG, 3-conductor. The wall plug must be a 2-pole grounding type with a NEMA 5-15P (15 A, 125 V) or NEMA 6-15P (15 A, 250 V) configuration.
3. The appliance coupler, flexible cord, and wall plug must bear a "T" mark and registration number in accordance with the Japanese Dentori Law. The flexible cord must be Type VCT or VCTF, 3-conductor, 1.00 mm² conductor size. The wall plug must be a 2-pole grounding type with a Japanese Industrial Standard C8303 (7 A, 125 V) configuration.

Screw Listing

This appendix provides specification and reference information for the screws used in the HP Notebook Expansion Base. All screws listed in this appendix are available in the Miscellaneous Screw Kit, spare part number 347439-001.

Table C-1
Phillips PM2.5×17.0 Screw

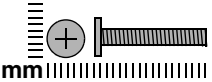
	Color	Qty.	Length	Thread	Head Width
mm	Bronze	4	17.0 mm	2.5 mm	6.0 mm

Where used:

Four screws that secure the base plate to the base enclosure
(documented in [Section 5.4](#))



Phillips M2.5×17.0 screw locations

Table C-2
Phillips PM2.0×6.0 Screw

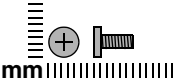
	Color	Qty.	Length	Thread	Head Width
	Bronze	10	6.0 mm	2.0 mm	4.5 mm

Where used:

Five screws that secure the power supply to the base enclosure
[\(documented in Section 5.6\)](#)

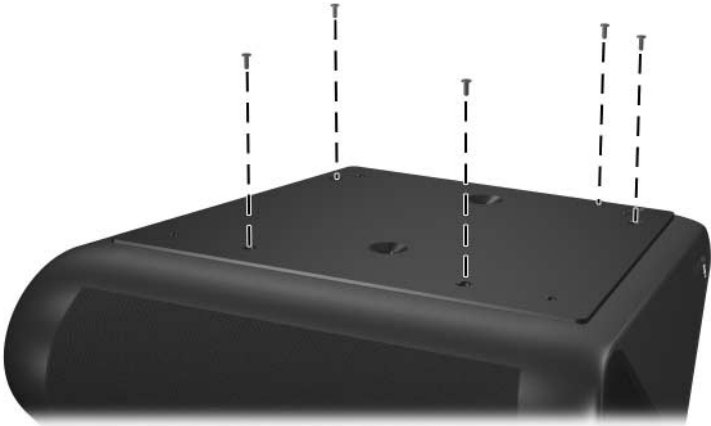

Phillips M2.0×6.0 screw locations

Table C-2
Phillips PM2.0×6.0 Screw (Continued)

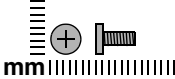
	Color	Qty.	Length	Thread	Head Width
	Bronze	10	6.0 mm	2.0 mm	4.5 mm

Where used:

Two screws that secure the rear cover to the base enclosure
[\(documented in Section 5.5\)](#)



Phillips M2.0×6.0 screw locations

Table C-2
Phillips PM2.0x6.0 Screw (Continued)

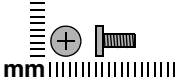
	Color	Qty.	Length	Thread	Head Width
	Bronze	10	6.0 mm	2.0 mm	4.5 mm

Where used:

Three screws that secure the system board to the base enclosure
[\(documented in Section 5.7\)](#)

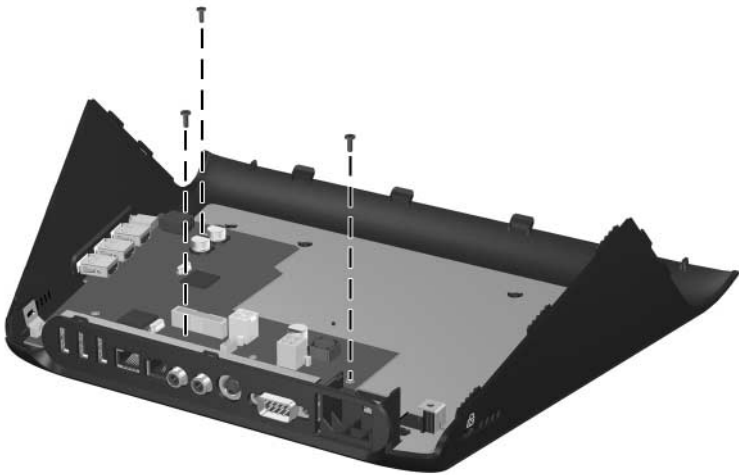

Phillips M2.0x6.0 screw locations

Table C-4
HM5.0×9.0 Standoff

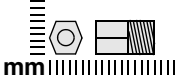
	Color	Qty.	Length	Thread	Head Width
	Silver	2	9.0 mm	5.0 mm	5.0 mm

Where used:

Two standoffs that secure the system board to the base enclosure
(documented in [Section 5.7](#))

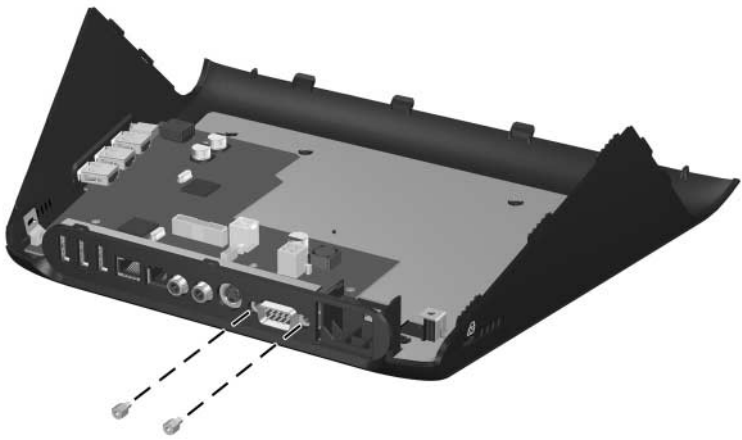

HM5.0×9.0 screw locations

Table C-5
Phillips PM2.0×4.0 Screw

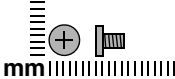
	Color	Qty.	Length	Thread	Head Width
	Bronze	18	4.0 mm	2.0 mm	4.0 mm

Where used:

Two screws that secure the upper chassis to the base enclosure
[\(documented in Section 5.5\)](#)



Phillips M2.0×4.0 screw locations

Table C-5
Phillips PM2.0x4.0 Screw (Continued)

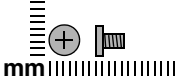
	Color	Qty.	Length	Thread	Head Width
	Bronze	18	4.0 mm	2.0 mm	4.0 mm

Where used:

Four screws that secure the front tray cover to the upper chassis
[\(documented in Section 5.8\)](#)

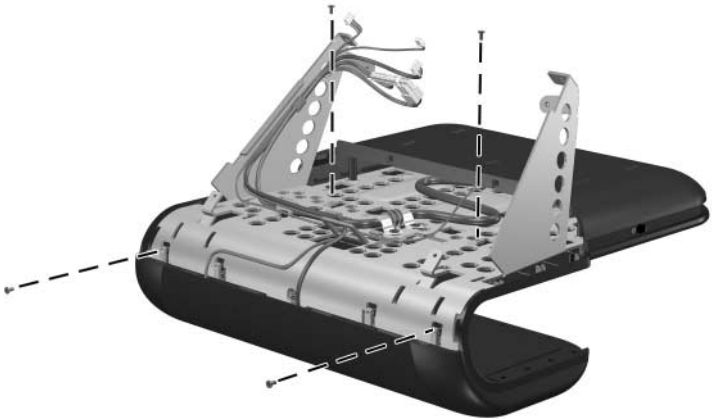

Phillips M2.0x4.0 screw locations

Table C-5
Phillips PM2.0x4.0 Screw (Continued)

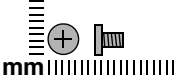
	Color	Qty.	Length	Thread	Head Width
	Bronze	18	4.0 mm	2.0 mm	4.0 mm

Where used:

Four screws that secure the back panel to the chassis
[\(documented in Section 5.9\)](#)

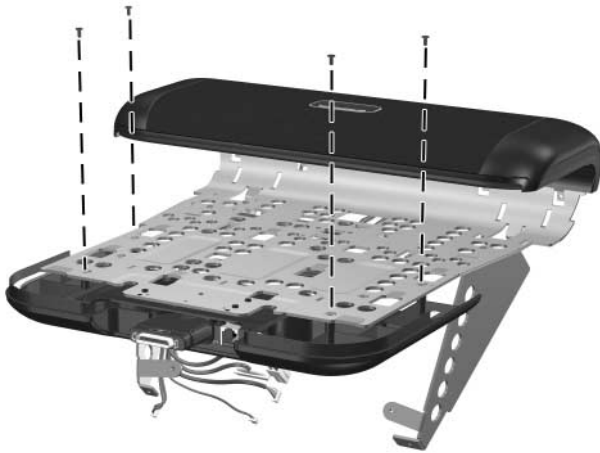

Phillips M2.0x4.0 screw locations

Table C-5
Phillips PM2.0x4.0 Screw (Continued)

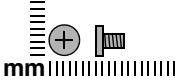
	Color	Qty.	Length	Thread	Head Width
	Bronze	18	4.0 mm	2.0 mm	4.0 mm

Where used:

Two screws that secure the speaker assembly to the chassis
[\(documented in Section 5.11\)](#)

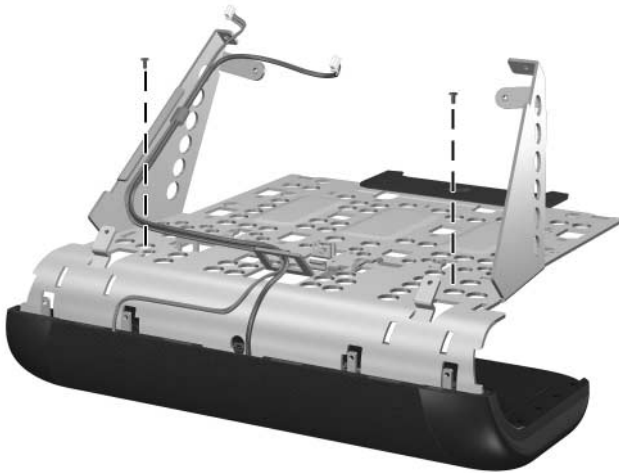

Phillips M2.0x4.0 screw locations

Table C-5
Phillips PM2.0×4.0 Screw (Continued)

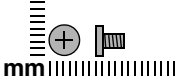
	Color	Qty.	Length	Thread	Head Width
	Bronze	18	4.0 mm	2.0 mm	4.0 mm

Where used:

Six screws that secure the front case to the chassis
 (documented in [Section 5.12](#))

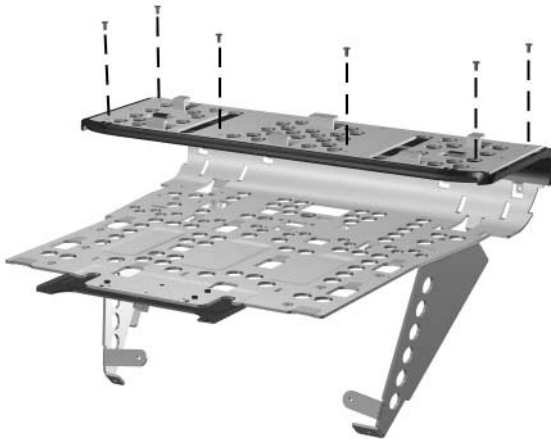

Phillips M2.0x4.0 screw locations

Table C-6
Phillips PM2.0x2.0 Screw

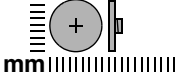
	Color	Qty.	Length	Thread	Head Width
	Silver	4	2.0 mm	2.0 mm	8 mm

Where used:

Four screws that secure the expansion cable brackets to the chassis
(documented in [Section 5.10](#))

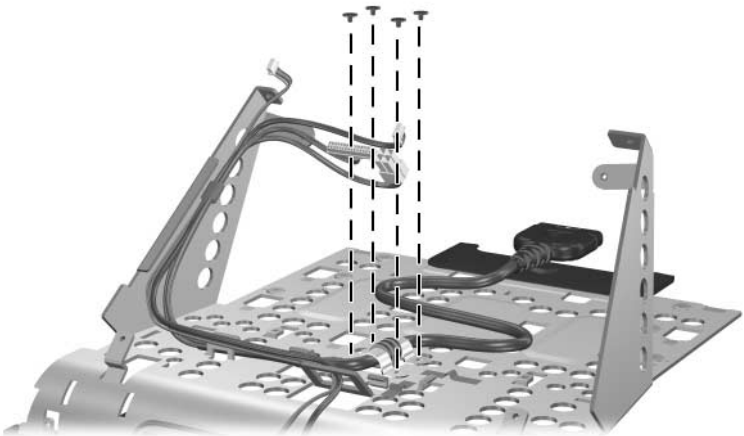

Phillips M2.0x2.0 screw locations

Index

A

- AC adapter specifications 6–2
- audio line-out pin assignments
A–3

B

- back panel
 - removal 5–16
 - spare part number 3–3
- base enclosure, spare part number
3–3
- base plate
 - removal 5–5
 - spare part number 3–3

C

- cables, service considerations 4–2
- components
 - front 1–3
 - left-side 1–5
 - rear 1–5
 - right-side 1–3, 1–5
- composite jack 1–7
- connection indicator light 1–4
- connector pin assignments
 - audio line-out A–3
 - modem jack A–2
 - network jack A–1
 - RJ-11 telephone jack A–2

- RJ-45 network jack A–1
- S/PDIF audio line-out jack A–5
- serial connector A–4
- S-Video connector A–3
- USB connectors A–2
- connectors, service considerations
4–2

D

- design overview 1–10
- disassembly sequence chart 5–3

E

- electrostatic discharge 4–2, 4–6
- expansion base specifications 6–1
- expansion cable 1–4, 1–7
 - disconnecting 5–4
 - removal 5–17
 - spare part number 3–3

F

- features 1–2
- front case
 - removal 5–20
 - spare part number 3–3
- front components 1–3
- front tray cover
 - removal 5–14
 - spare part number 3–3

G

grounding equipment and methods
4–5

H

headphone jack 1–5

K

keyboard, wireless 1–9

L

left-side components 1–5

M

Miscellaneous Plastics Kit, spare
part number 3–3
modem jack, pin assignments A–2
mouse, wireless 1–9
mute button 1–4

N

network jack, pin assignments A–1

P

packing precautions 4–3
plastic parts 4–2
power connector 1–7
power cord set requirements B–1
power cord, spare part numbers
3–6
power supply
removal 5–10
spare part number 3–3

R

rear components 1–5
rear cover
removal 5–6
spare part number 3–3

receiver

function 1–9
spare part number 3–5
removal preliminaries 4–1
replacement preliminaries 4–1
right-side components 1–3, 1–5
RJ-11 telephone jack
location 1–7
pin assignments A–2
RJ-45 network jack
location 1–7
pin assignments A–1

S

S/PDIF audio line-out jack
pin assignments A–5
S/PDIF connector location 1–7
screw listing C–1
security cable slot 1–5, 1–8
serial connector
location 1–7
pin assignments A–4
serial number 3–1, 5–2
service considerations 4–1
speaker assembly
location 1–4
removal 5–18
spare part number 3–3
specifications
AC adapter 6–2
expansion base 6–1
static shielding materials 4–6
S-Video connector
location 1–7
pin assignments A–3

system board
 removal 5–12
 spare part number 3–3
system board cables, removal 5–8

T

tools required 4–1
transporting precautions 4–3
troubleshooting 2–1
 problems and solutions 2–2
TV out, location 1–7

U

upper chassis
 removal 5–6
 spare part number 3–3
USB connectors
 location 1–5, 1–7
 pin assignments A–2

V

vent 1–5, 1–7, 1–8
volume down button 1–4
volume up button 1–4

W

wireless accessories 1–9
wireless keyboard 1–9
 spare part numbers 3–5
wireless mouse 1–9
 spare part number 3–5
workstation precautions 4–4